

REVISIONS			
REV	DESCRIPTION	DATE	APPROVED
01 ₀	RELEASED	10/9/97	<i>DCamello</i>

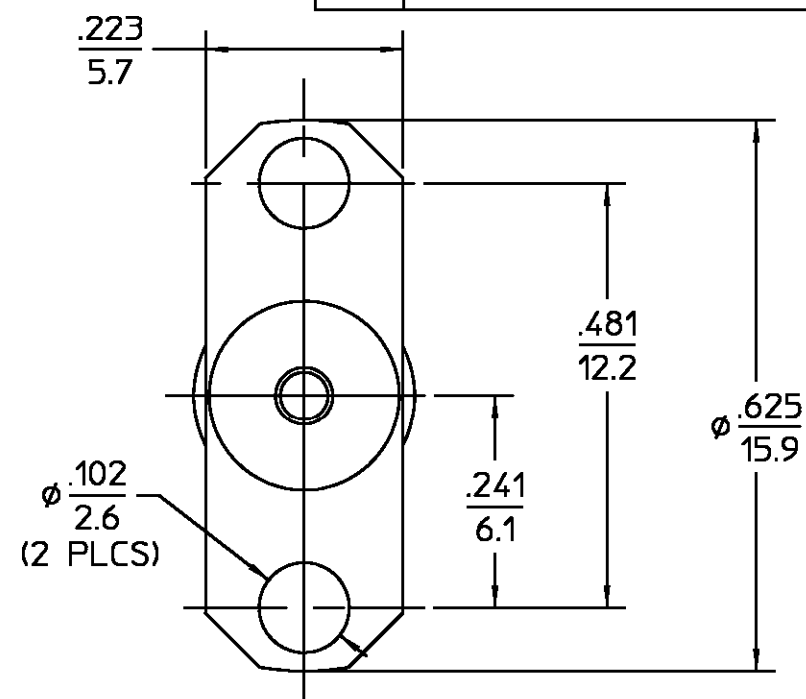
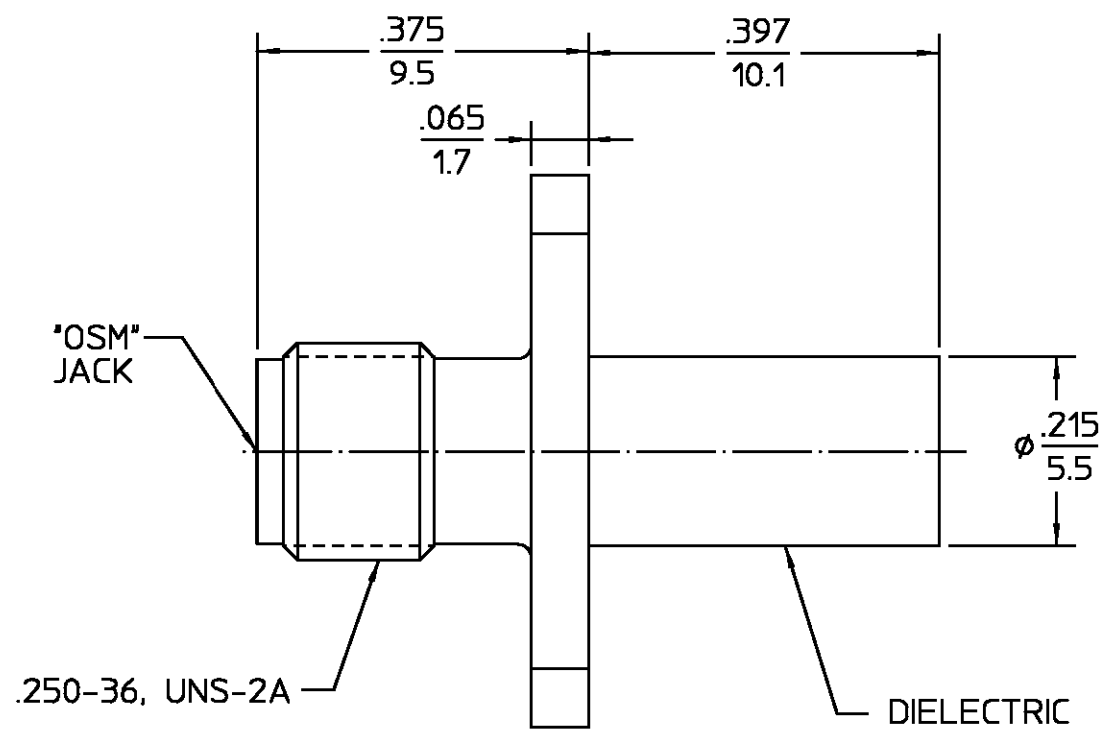

ELECTRICAL	MECHANICAL	ENVIRONMENTAL
Nominal Impedance (Ohms) <u>50</u>	Interface Dimensions MIL-STD-348A, Fig. <u>310-2</u>	Temperature Rating <u>-65°C TO +125°C</u>
Frequency Range (GHz) DC to <u>NOT RATED</u>	Recommended Mating Torque <u>7-10 IN-LBS</u>	Vibration MIL-STD-1344, Method 2005, Condition IV
Volt Rating (VRMS MAX) @ Sea Level <u>335</u>	Mating Characteristics: Insertion (MAX Lbs) <u>3.0</u>	Shock MIL-STD-1344, Method 2004, Condition G
VSWR <u>N/A</u>	Withdrawal (MIN Oz) <u>1.0</u>	Thermal Shock MIL-STD-1344, Method 1003, Condition A, Except High Temp 115°C
Insertion Loss (dB MAX) <u>N/A</u>	Force to Engage and Disengage (In-Lbs MAX) <u>2.0</u>	Moisture Resistance MIL-STD-202, Method 106
RF Leakage (dB MIN) <u>N/A</u>	Center Contact Captivation Axial (Lbs) <u>6.0</u>	Corrosion - MIL-STD-202, Method 101, Condition B, 5% salt spray
Corona, 70,000 Ft (VRMS MIN) <u>250</u>	Radial (In-Oz) <u>N/A</u>	
Dielectric Withstanding Voltage (VRMS MIN) @ Sea Level <u>1,000</u>	Cable Retention Axial Force (Lbs) <u>N/A</u>	
Contact Resistance (Milliohms MAX) Center Contact <u>3.0</u>	Torque (In-Oz) <u>N/A</u>	
Outer Contact <u>2.0</u>	Weight (Grams) <u>TBD</u>	
Cable to Housing <u>N/A</u>		
RF High Potential @ Sea Level (VRMS MIN @ 5 MHz) <u>670</u>		
LR.(Megohms MIN) <u>5,000</u>		

COMPONENT	MATERIAL	FINISH
HOUSING	STAINLESS STEEL PER ASTM-A484 AND ASTM-A582, TYPE 303	GOLD PLATE PER MIL-G-45204
DIELECTRIC	PTFE FLUOROCARBON PER ASTM-D-1457	N/A
CENTER CONTACT	BERYLLIUM COPPER PER ASTM-B-196 OR ASTM-B-197, ALLOY C17300, CONDITION H	GOLD PLATE PER MIL-G-45204

UNLESS OTHERWISE SPECIFIED DIMENSIONS ARE IN INCHES	DRAWN BY	DATE	AMP Incorporated 140 Fourth Avenue Waltham, MA 02451-7599
	KYLE LE	10-8-97	
FRAC. DEC. ANGLES	CHECKED BY	APPRD BY	TITLE
± 1/64 ±.005 ± 1°		<i>DCamello</i> 10/9/97	'OSM' 2 HOLE FLANGE JACK RECEPTACLE-STRAIGHT TERMINAL
These drawings and specifications are the property of AMP Incorporated and shall not be reproduced or copied or used in whole or in part as the basis for the manufacture or sale of item(s) without written permission.	USE ASSY PROCEDURE	NO. A.P. <u>N/A</u>	SIZE
			B
			CODE IDENT NO.
			26805
			2052-3979-00
			REV
			01 ₀
			SCALE
			6:1
			SHEET 1 OF 1

Mouser Electronics

Authorized Distributor

Click to View Pricing, Inventory, Delivery & Lifecycle Information:

[TE Connectivity:](#)

[1223136-1](#)