

NUMBER GS-12-319	TYPE PRODUCT SPECIFICATION		
TITLE PCI EXPRESS™ & Express Module press fit CONNECTOR		PAGE 1 of 10	REVISION K
		AUTHORIZED BY Bill Lin	DATE 4/19/2010
CLASSIFICATION UNRESTRICTED			

TABLE OF CONTENTS

SECTION 1 INTRODUCTION

SECTION 2 GENERAL REQUIREMENTS

SECTION 3 MECHANICAL

- 3.1 EXAMINATION OF PRODUCT
- 3.2 INSERTION/WITHDRAWAL FORCES – ADD IN CARD
- 3.3 CONTACT RETENTION
- 3.4 BOARD INSERTION/RETENTION FORCE

SECTION 4 ELECTRICAL

- 4.1 LOW LEVEL CONTACT RESISTANCE
- 4.2 INSULATION RESISTANCE
- 4.3 DIELECTRIC WITHSTANDING
- 4.4 CONTACT CURRENT RATING
- 4.5 INSERTION LOSS
- 4.6 RETURN LOSS
- 4.7 CROSSTALK

SECTION 5 ENVIRONMENTAL

- 5.1 THERMAL SHOCK
- 5.2 CYCLIC TEMPERATURE AND HUMIDITY
- 5.3 TEMPERATURE LIFE (PRE-CONDITIONING)
- 5.4 TEMPERATURE LIFE
- 5.5 VIBRATION
- 5.6 DURABILITY (PRE-CONDITIONING)
- 5.7 DURABILITY
- 5.8 MIXED FLOWING GAS
- 5.9 RESEATING
- 5.10 RESISTANCE TO SOLDER HEAT

SECTION 6 TEST MATRIX

1.0 INTRODUCTION

NUMBER GS-12-319	TYPE PRODUCT SPECIFICATION		
TITLE PCI EXPRESS™ & Express Module press fit CONNECTOR		PAGE 2 of 10	REVISION K
		AUTHORIZED BY Bill Lin	DATE 4/19/2010
CLASSIFICATION UNRESTRICTED			

1.1 SCOPE

This document describes the functional and test requirements for the PCI Express™ card-edge connector. The connector is designed to meet the requirements of the PCI Express Press Fit.

1.2 APPLICABLE DOCUMENTS

- 1.2.1 PCI Express Card Electromechanical Specification
- 1.2.2 EIA -90, EIA-364-09,17,20,21,28,31,32,65,70,101,108,638
- 1.2.3 PCI Express Connector High Speed Electrical Test Procedure.
- 1.2.4 FCI drawing, PCI Express connector, inspection & customer copy.
- 1.2.5 FCI drawing, solder washer, 78523 : inspection copy.

1.3 DRAWING PRECEDENCE

In the event of conflict between this document and product prints, the product prints shall take precedence.

2.0 GENERAL REQUIREMENTS

- 2.1 The connector has the following characteristics:
1.00m(0.040") pitch, X1, X4, X8, X12, X16, 280P sizes, Press Fit, rectangular outline, plastic peg requiring TH holes on PCB.
- 2.2 Visual examination, unless otherwise specified, shall be made at 7X.
- 2.3 Silicone compounds (mold releases, lubricants, etc.) May not be used in the manufacturing processes.
- 2.4 Flammability to be rated UL 94V-0.
- 2.5 Unless otherwise specified, tests that require the use of a pc edge card shall use the following
 - 2.5.1 Card material: FR-4 glass epoxy.
 - 2.5.2 Thickness: 1.57 +/- 0.13 (0.062 +/- 0.005 inch)
 - 2.5.3 Trace material: 0.035 (0.0014 inches), copper.
 - 2.5.4 Trace plating: 0.76 micrometers (30 micro inches) minimum gold over 1.27 micrometers (50 micro inches) minimum unbrushed nickel
 - 2.5.5 Pad and trace design: pad and trace design shall follow PCI Express standard as depicted in customer drawing.

NUMBER GS-12-319	TYPE PRODUCT SPECIFICATION		
TITLE PCI EXPRESS™ & Express Module press fit CONNECTOR		PAGE 3 of 10	REVISION K
		AUTHORIZED BY Bill Lin	DATE 4/19/2010
CLASSIFICATION UNRESTRICTED			

3.0 MECHANICAL REQUIREMENTS

3.1 EXAMINATION OF PRODUCT

Samples must comply to applicable FCI product prints.

3.2 INSERTION / WITHDRAWAL FORCE- ADD IN CARD PER EIA-364-13

Mating cycle is with maximum/minimum thickness gage at a rate of 25.4 mm/minute.

3.2.1 Maximum insertion force is 1.15 N max. per contact pair when measured with a 1.70 +0.00/- 0.01(0.067 +0.000/ -0.004 inches) thick hardened steel card made to the dimensions shown for the PCI Express expansion board in the FCI customer drawing. The card has a R0.05 min., R0.10 max.(sharpedge)and the surface roughness in connector area to be 0.10 micrometers (4 microinches) maximum.

3.2.2 Withdrawal force is 0.15N minimum per contact pair when measured with a 1.44 +0.01/- 0.00 (0.067 +0.004/-0.000 inches) thick FR-4 PCB card made to the dimensions shown for the PCI Express expansion board in the FCI customer drawing. The card has a R0.05 min., R0.10 max (sharp edge) and the surface roughness in the connector area to be 0.10 micrometers (4 microinches) maximum.

3.3 CONTACT RETENTION

Minimum retention force of terminals in the connector housing to be 3N each. Pull rate to be 1.27 mm/min.

3.4 BOARD RETENTION / INSERTION FORCES

3.4.1 EON retention/insertion force should be checked on an 1.57 ± 0.13 (0.093 ± 0.05 inch) thick segment of FR-4 glass/epoxy circuit board segment with a hole of diameter 0.72 ± 0.06 mm drilled through.

At a rate of 2.5 ± 6 mm per minute:

Insert force no more than 4.54 Kgf(10Lbs) per pin.

Retention force no less than 0.67 Kgf(1.5Lbs) per pin.

3.4.2 PCB Hole Deformation Radius-Cross-section parallel to board surface. Photograph and measure the hole deformation (deformation on board material) radius at a point 0.010" from the surface, and at the center of the compliant pin section. Include 10 holes. The average (of 10 holes) hole deformation radius shall be no greater than 0.0381 mm (0.0015 in)when measured from the drilled hole. The absolute maximum deformation radius shall not exceed 0.0508 mm (0.002 in). Reference MIL-STD-2166.

3.4.3 PCB Hole Wall Damage-Cross-section perpendicular to the board surface, and through the compliant section wear track. Photograph and measure the copper thickness remaining between the compliant pin and the printed wiring board laminate. Include 10 holes. The minimum average (of 10 holes) copper thickness remaining between the compliant pin and the printed wiring board laminate shall not be less than 0.00762 mm(0.0003 in). In addition there shall be no copper cracks, separations between conductive interfaces, or laminate-to-copper separations. Reference MIL-STD-2166.

NUMBER GS-12-319	TYPE PRODUCT SPECIFICATION		
TITLE PCI EXPRESS™ & Express Module press fit CONNECTOR		PAGE 4 of 10	REVISION K
		AUTHORIZED BY Bill Lin	DATE 4/19/2010
CLASSIFICATION UNRESTRICTED			

4.0 ELECTRICAL REQUIREMENTS

Unless otherwise specified, all measurements should be performed in the following ambients:

relative humidity: 50% or less

temperature: 25°C +/- 5°C

barometric pressure:

711 to 812 mm mercury (at sea level)

4.1 LOW LEVEL CONTACT RESISTANCE EIA-364-23

4.1.1 Solder connector to pc board per section 2.6 and insert card per section 2.5

4.1.2 Resistance measurements should be made from the underside of the pc board to the PTH in the add in card above the contact pad. The test current shall be 100 milliamperes d.c. max. with a maximum open circuit voltage of 20 millivolts D.C. See figure 1.0 for attachment of current and voltage leads.

4.1.3 Requirement is 30 milliohms maximum initial, with change of 10 milliohms maximum after exposure testing.

NUMBER GS-12-319	TYPE PRODUCT SPECIFICATION	FCI	
TITLE PCI EXPRESS™ & Express Module press fit CONNECTOR		PAGE 5 of 10	REVISION K
		AUTHORIZED BY Bill Lin	DATE 4/19/2010
CLASSIFICATION UNRESTRICTED			

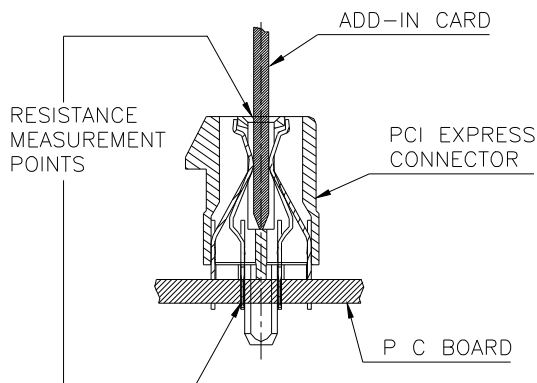

PCI Express

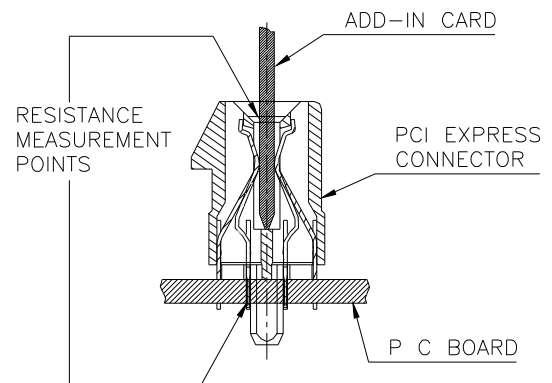

PCI Express ExpressModule

**CONTACT RESISTANCE TEST SET UP
THROUGH HOLE
FIGURE 1**

4.2 INSULATION RESISTANCE

Requirement is 1000 megohm minimum at 100 + / - 10% vdc when tested to EIA-364-21 per spec. The connector shall not be mated during insulation resistance measurement.

4.3 DIELECTRIC WITHSTANDING

Per EIA-364-20 method B per spec. Test potential to be 300 VAC RMS, 60 HZ, and applied for 1 minute. No breakdown should occur. Test is performed with connector unmated.

4.4 CONTACT CURRENT RATING

NUMBER GS-12-319	TYPE PRODUCT SPECIFICATION		
TITLE PCI EXPRESS™ & Express Module press fit CONNECTOR		PAGE 6 of 10	REVISION K
		AUTHORIZED BY Bill Lin	DATE 4/19/2010
CLASSIFICATION UNRESTRICTED			

1.1 amp per contact minimum per EIA-364-70, method 2 and *PCI Express Connector High Speed Electrical Test Procedure*. The temperature rise shall not exceed 30 degree C. Ambient condition is still air at 25°C.

4.5 INSERTION LOSS

Per EIA-364-101 and PCI Express Connector High Speed Electrical Test Procedure.

Requirements:

- Less than or equal to 1dB up to 1.25 GHz
- Less than or equal to $1.6 \times (F-1.25)+1$ db between 1.25GHz and 3.75GHz.
- Less than or equal to 5 dB at 3.75 GHz

4.6 RETURN LOSS

Per EIA-364-108 and *PCI Express Connector High Speed Electrical Test Procedure*.

Requirements:

- Less than or equal to -12dB up to 1.3 GHz
- Less than or equal to -7dB up to 2.0 GHz
- Less than or equal to -4dB up to 3.75 GHz

4.7 CROSSTALK: NEXT

Per EIA-90 and *PCI Express Connector High Speed Electrical Test Procedure*.

Requirements:

- Less than or equal to -32 dB max up to 1.25 GHz
- Less than or equal to $-(32 - 2.4 \times (F-1.25))$ db between 1.25 GHz and 3.75GHz.
- Less than or equal to -26 dB max up to 3.75 GHz

5.0 ENVIRONMENTAL REQUIREMENTS (Per EIA-364-1000.01)

5.1 THERMAL SHOCK

Per EIA-364-32, test condition I, 10 cycles

5.2 CYCLIC TEMPERATURE AND HUMIDITY

Per EIA-364-31, 24 cycles
Per EIA-364-TS-1000.01 TEST GROUP 2

5.3 TEMPERATURE LIFE (Pre-conditioning)

Per EIA-364-17, method A, 92 hours at 105°C

5.4 TEMPERATURE LIFE

Per EIA-364-17, method A, 168 hours at 105°C

5.5 VIBRATION

Per EIA-364-28, test condition VII, test condition letter D.
(15 minutes in each of 3 mutually perpendicular directions.)

NUMBER GS-12-319	TYPE PRODUCT SPECIFICATION		
TITLE PCI EXPRESS™ & Express Module press fit CONNECTOR		PAGE 7 of 10	REVISION K
		AUTHORIZED BY Bill Lin	DATE 4/19/2010
CLASSIFICATION UNRESTRICTED			

Both mating halves should be rigidly fixed so as not to contribute to the relative motion one contact Against another. The method of fixturing should be detailed in the test report.) 2/2 (boards) 2 conn/board. Supplier Certification Data.

Requirements: no evidence of physical damage and discontinuities of one microsecond or greater duration are allowed.

5.6 DURABILITY (Pre-conditioning)
CYCLE RATE : 500 MATING / HOUR
Per EIA-364-09, 20 cycles

5.7 DURABILITY
CYCLE RATE : 500 MATING / HOUR
Per EIA-364-09, 50 cycles

5.8 MIXED FLOWING GAS

Per EIA-364-65, class IIA, 10 days exposure. Expose connectors unmated for 2/3 of the total duration. Mate each connector to the same add-in card that it was mated to in temperature life (preconditioning) and expose for the remainder of the test duration.

5.9 RESEATING

Manually plug/unplug the card and connector, 3 cycles.

5.10 RESISTANCE TO SOLDERING HEAT

Per EIA-364-56 procedure 3, test condition C.
260°±5°C 10±2 seconds

6.0 Test Matrix for 1X,4X,8X,16X & 280P



NUMBER GS-12-319	TYPE PRODUCT SPECIFICATION		
TITLE PCI EXPRESS™ & Express Module press fit CONNECTOR		PAGE 8 of 10	REVISION K
		AUTHORIZED BY Bill Lin	DATE 4/19/2010
CLASSIFICATION UNRESTRICTED			

TABLE 1 - QUALIFICATION TESTING MATRIX

	TEST GROUP	TEST GROUP	TEST GROUP	TEST GROUP	TEST GROUP	TEST GROUP	TEST GROUP	TEST GROUP	TEST GROUP	TEST GROUP	TEST GROUP
TEST	PARA	TEST SEQUENCE									
Examination of Product	3.1	1	1	1	1	1	1	1	1	1	1
Insertion/Withdrawal Force – Add In Card	3.2					2					
Contact Retention	3.3					3					
Board Retention /Insertion Forces	3.4										2
Low Level Contact Resistance	4.1	2,5,7	2,5,8,10	2,5,7	2,5,7,9,11				3,5		
Insulation Resistance	4.2		7								
DWV	4.3							2,6			
Contact Current Rating	4.4								2		
Insertion Loss	4.5						2				
Return Loss	4.6						3				
Crosstalk	4.7						4				
Thermal Shock	5.1		4		8						
Cyclic Temp and Humidity	5.2		6								
Temperature Life (pre-conditioning)	5.3			4	4						
Temperature Life	5.4	4									
Vibration	5.5			6							
Durability (pre-conditioning)	5.6	3	3	3	3						
Durability	5.7							4			
Mixed Flowing Gas	5.8				6						
Reseating	5.9	6	9		10						
Resistance to soldering heat	5.10									2	
Sample Quantity / Group		16X-5⁽¹⁾ 280-5⁽¹⁾	16X-5	16X-5 280-5	16X-10⁽²⁾	16X-10,8X-10, 4X-10,1X-10⁽³⁾ 280-10	4X-3	16X-10⁽⁴⁾ 280-10⁽¹⁾	16X-4⁽⁵⁾	16X-3 Plastic peg 16X-3 board lock	16X-3

Notes:

1. samples for test groups 1,2,3,6 & 8 have metal hold downs, phos bronze contacts and 0.38 micrometers (15 u”) gold plate, and black housings.
2. samples for test group 4:
 - a. 5 each same as note 1
 - b. 5 each same as note except with 0.76 micrometers (30u”) gold plate.

NUMBER GS-12-319	TYPE PRODUCT SPECIFICATION		
TITLE PCI EXPRESS™ & Express Module press fit CONNECTOR		PAGE 9 of 10	REVISION K
		AUTHORIZED BY Bill Lin	DATE 4/19/2010
CLASSIFICATION UNRESTRICTED			

- 3. samples for test group 5:
 - a. 5 each same as note 1
 - b. 5 each same as note except with plastic locating pegs.
- 4. samples for test group 7:
 - a. 5 each same as note 1
 - b. 5 each same as note except with 0.76 micrometers (30U") gold plate.
- 5. samples for test group 8:
 - a. 2 each same as note 1
 - b. 2 each same as note except with 0.76 micrometers (30U") gold plate.

REVISION RECORD

NUMBER GS-12-319	TYPE PRODUCT SPECIFICATION		
TITLE PCI EXPRESS™ & Express Module press fit CONNECTOR		PAGE 10 of 10	REVISION K
		AUTHORIZED BY Bill Lin	DATE 4/19/2010
CLASSIFICATION UNRESTRICTED			

REV	PAGE	DESCRIPTION	ECR #	DATE
A	ALL	RELEASED	T05-0056	03/15/05
B	ALL	ADD 3.4.2 & 3.4.3	T05-0064	03/23/05
C	ALL	MODIFY 5.6.5	T05-0090	04/25/05
D	ALL	ADD Express Module TYPE	T05-0170	08/04/05
E	ALL	5.2 ADD EIA-364-TS-1000.01 TEST GROUP 2	T05-0202	09/09/05
F	ALL	MODIFY 3.2.2	T06-0007	01/10/06
G	ALL	1. Change new FCI format 2. Change 0.70+/-0.06 to 0.72+/-0.06 in item 3.4.1 in order to correct type mistake	DG07-0205	05/28/07
H	ALL	Change 3.4.1 Retention force no less than 0.91 Kgf(2Lbs) per pin Change to Retention force no less than 0.67 Kgf(1.5Lbs) per pin	DG07-0251	06/20/07
J	ALL	3.2.2 "Withdrawal force is 0.10N minimum per contact pair" is changed to "Withdrawal force is 0.15N minimum per contact pair"	DG07-0507	12/25/07
K	ALL	Change the confidential form to unrestricted form	DG10-0145	04/19/10

Mouser Electronics

Authorized Distributor

Click to View Pricing, Inventory, Delivery & Lifecycle Information:

[FCI:](#)

[10039755-10103TLF](#) [10039755-10000TLF](#) [10039755-10001TLF](#) [10039755-10002TLF](#) [10039755-10003TLF](#)
[10039755-10100TLF](#) [10039755-10101TLF](#) [10039755-10102TLF](#) [10044013-10000TLF](#) [10044013-10100TLF](#)
[10055293-10000TLF](#) [10055293-10010TLF](#) [10055293-10310T](#) [10055295-10000TLF](#)