

824-BU Product Details

[Share](#) [Print](#) [Email](#)

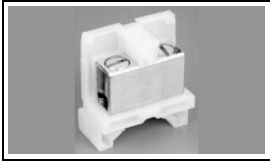

824-BU

(1437395-3)

TE Internal Number: 1437395-3

Active

[View 3D PDF](#)

NEMA Terminal Blocks

Always EU RoHS/ELV Compliant (Statement of Compliance)

Product Highlights:

- 800 Series Block Series
- NEMA Product Line
- Contact Configuration = Tubular Screw
- Intermediate Heavy Duty Application
- Mount Style = Direct Mount (Flat Base) or Channel Mount (Dovetail Base)

[View all Features](#)

Quick Links

- ▶ [Pricing & Availability](#)
- ▶ [Search for Tooling](#)
- ▶ [Product Feature Selector](#)
- ▶ [Contact Us About This Product](#)

[Add to My Part List](#)

[Request Sample](#)

[Find Similar Products](#)

[Buy Product](#)

Documentation & Additional Information

Product Drawings:

- [ASSEMBLY, TERMINAL BLOCK, NEMA DOVETAIL BASE, HEAVY ... \(PDF, English\)](#)

Catalog Pages/Data Sheets:

- [BUCHANAN TERMINAL BLOCKS CATALOG - NEMA TERMINAL BLOCKS \(PDF, English\)](#)

Product Specifications:

- None Available

Application Specifications:

- None Available

Instruction Sheets:

- None Available

CAD Files: [\(CAD Format & Compression Information\)](#)

- [2D Drawing \(DXF, Version A\)](#)
- [3D Model \(IGES, Version A\)](#)
- [3D Model \(STEP, Version A\)](#)

[List all Documents](#)

Additional Information:

- [Product Line Information](#)

Additional Product Images:

- [Line Drawing](#)
- [Typical Assembly View](#)

Related Products:

- [Tooling](#)

Product Features (Please use the Product Drawing for all design activity)

Product Type Features:

- [Block Series](#) = 800 Series
- Product Line = NEMA
- Screw Size = 7/16-20 Slotted Headless

Electrical Characteristics:

- Voltage Rating (VAC) = 600
- Amperes (A) = 155.0

Body Features:

- Mount Style = Direct Mount (Flat Base) or Channel Mount (Dovetail Base)
- [Wire Range \(Solid and Stranded\)\[MCM\] \(AWG\)](#) = 12-1/0
- [Blown Fuse Indicator](#) = Without
- [Blown Fuse Indicator Type](#) = None
- Wire Strip Length (mm [in]) = 17.48 [0.688]

Contact Features:

- Contact Configuration = Tubular Screw
- Pitch (mm [in]) = 19.05 [0.750]

Housing Features:

- [Housing Material](#) = Nylon (Painted)
- UL Flammability Rating = UL 94V-2

Industry Standards:

- [RoHS/ELV Compliance](#) = RoHS compliant, ELV compliant
- [Lead Free Solder Processes](#) = Not relevant for lead free process
- [RoHS/ELV Compliance History](#) = Always was RoHS compliant

Conditions for Usage:

- Temperature, Max. (°C) = 125

Operation/Application:

- Application = Intermediate Heavy Duty

Packaging Features:

- Terminals Per Foot = 15

Other:

- Brand = Buchanan

Corporate Information

[About TE](#)
[Investors](#)
[News Room](#)
[Supplier Portal](#)
[Careers](#)

Quick Links

[Distributor Inventory](#)
[Product Cross Reference](#)
[Documents & Drawings](#)
[Product Compliance Support Center](#)
[Site Map](#)

Customer Support

[Email or Chat With Us](#)
[Find a Phone Number](#)
[Knowledge Base](#)
[Manage Your Account](#)

LOC	DIST	REVISIONS					
—	—	P	LTR	DESCRIPTION	DATE	DWN	APVD
			A	REDRAWN PER ECO-08-023052	30SEP08	HMR	SM

1 MATERIAL: NYLON

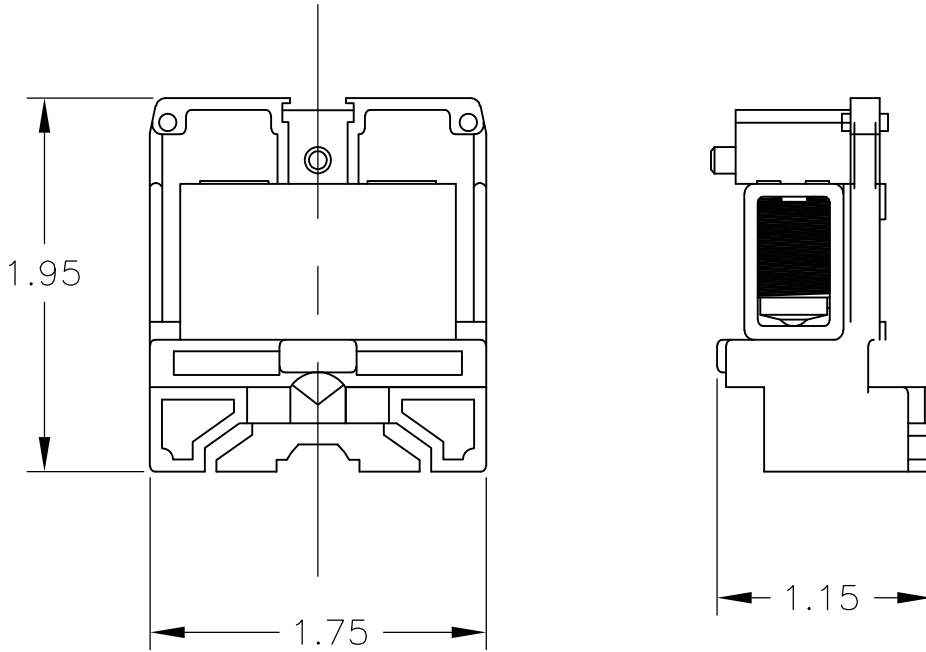

RELEASED FOR PUBLICATION

ALL INTERNATIONAL RIGHTS RESERVED.

BY TYCO ELECTRONICS CORPORATION.

THIS DRAWING IS UNPUBLISHED.

© COPYRIGHT

824-BU	1437395-3
814	1437395-2
CATALOG P/N	PART NUMBER

DIMENSIONS: INCHES	DWN	30SEP08	MATERIAL	1	FINISH	-
	CHK	30SEP08	Tyco Electronics Corporation Harrisburg, PA 17105-3608			
TOLERANCES UNLESS OTHERWISE SPECIFIED:	APVD	30SEP08	NAME			
	PRODUCT SPEC		ASSEMBLY, TERMINAL BLOCK, NEMA DOVETAIL BASE, HEAVY DUTY, TUBULAR SCREW			
0 PLC ± -	APPLICATION SPEC		SIZE	CAGE CODE	DRAWING NO	RESTRICTED TO
1 PLC ± -			A4	00779	C-1437395-2	-
2 PLC ± -	WEIGHT	-	CUSTOMER DRAWING			
3 PLC ± .010			SCALE	1:1	SHEET	1 OF 1
4 PLC ± -					REV	A
ANGLES ± -						