

# 199 Power Relays

## GENERAL SPECIFICATIONS



DPDT



SPDT



SPST-DM

PART NUMBERS		199AX, 199X, 199AMX <sup>1</sup> , 199MX <sup>1</sup> , 199ABX <sup>2</sup> , 199BX <sup>2</sup>	199ADX, 199DX, 199ADYX, 199DYX, 199ADB <sup>2</sup> , 199DB <sup>2</sup>	199P <sup>3,4</sup> , 199AP <sup>3,4</sup>	199ADE, 199DE, 199ADBE <sup>2</sup> , 199DBE <sup>2</sup>
<b>CONTACT CHARACTERISTICS</b>					
Number and type of contacts		SPST, SPDT, DPST, DPDT	SPST-DM, SPST-DB	DPDT, SPDT	SPST-DM
Contact material		AgSnO			
Thermal (carrying) current rating		40 A		50 A	
Maximum switching voltage		600 V(rms)			
Rated Switching current at voltage	Resistive	40 A at 300 VAC; 5 A at 480 VAC; 5 A at 600 VAC; 40 A at 28 VDC	40 A at 300 VAC; 12 A at 480 VAC; 10 A at 600 VAC; 40 A at 28 VDC	50 A at 300 VAC; 5 A at 480 VAC; 5 A at 600 VAC; 50 A at 28 VDC	50 A at 300 VAC; 12 A at 480 VAC; 10 A at 600 VAC; 50 A at 28 VDC
	Motor	2 HP at 120 to 600 VAC			
	Tungsten	15 A at 120 VAC			
	Pilot duty	A600			
Minimum switching requirement		1 A at 5 VAC/VDC			
<b>COIL CHARACTERISTICS</b>					
Voltage range		6 to 600 VAC; 6 to 250 VDC			
Operating range (% of Nominal)		85% to 110% (AC); 80% to 110% (DC) <sup>5</sup>			
Average power consumption (Maximum)		10 VA; 4 W			
Drop-out voltage threshold		10% (AC/DC)			
<b>PERFORMANCE CHARACTERISTICS</b>					
Electrical life (IEC 60947-1)	Rated resistive load	Please refer to Table 3			
Operating time (response time)		30 ms			
Dielectric strength	Between coil and contact	2200 V	2200 V	2200 V	2200 V
	Between poles	2200 V	N/A	2200 V	N/A
	Between open contacts	1600 V	2200 V	1600 V	2200 V
<b>ENVIRONMENT</b>					
Product certifications		UL, CSA, CE, RoHS			
Ambient temperature range (around the device)		-55 to +100 °C (Storage) -55 to +55 °C (Operation)			
Termination <sup>3</sup>		10 (5.3) AWG (mm <sup>2</sup> )			
Terminal tightening torque		11 to 15 in-lb (1.2 to 1.7 Nm)			
Weight		227 to 312 g (8 to 11 oz)			

<sup>1</sup> For auxiliary switch ratings, please refer to Table 1.

<sup>2</sup> For ratings with blowout magnet, please refer to Table 2.

<sup>3</sup> For UL listed installations, proper wire rating and terminations required.

<sup>4</sup> Recommended ring, fork, or box wire termination.

<sup>5</sup> Recommended mounting positions: horizontal or vertical (not upside down).

**Table 1: Auxiliary Switch Ratings**

AUXILIARY SWITCH RATINGS	
Resistive Load 120/250 VAC (50/60 Hz)	10 A
Motor Load 125/250 VAC (50/60 Hz)	0.25 HP
Tungsten Load 125 VAC (50/60 Hz)	3 A

**Table 2: Additional DC Ratings with Blowout Magnets**

RELAY VOLTAGE	RATING W/BLOWOUT MAGNET
110 VDC	20 A
220 VDC	8 A
325 VDC	4 A
500 VDC	2 A

**Table 3: Contact Ratings & Electrical Endurance (per IEC 60947-1, 60947-4-1)**

CURRENT/HORSEPOWER RATINGS	LOAD VOLTAGE	FREQUENCY	LOAD TYPE	ESTIMATED ELECTRICAL ENDURANCE	SEE NOTE(S)
<b>AC LOAD</b>					
50 A	300 V	50/60 Hz	Resistive	25,000 cycles	1, 4
40 A				50,000 cycles	2, 4
2 HP	120 to 600 V	---	Motor	50,000 cycles	3, 4
15 A	120 V		Tungsten	20,000 cycles	4, 5
A600	---	---	Pilot Duty	100,000 cycles	4
<b>DC LOAD</b>					
40 A	28 V	DC	Resistive	100,000 cycles	4
20 A	110 V				
8 A	220 V				
4 A	325 V				
2 A	500 V				

**Notes:**

- 50 A rating refer to models with pressure wire connectors only.
- Resistive AC load ratings are based on a power factor of 0.85 to 1.0.
- Motor horsepower ratings are based on a power factor of 0.4 to 0.5, and an initial inrush current not in excess of six times the full load current.
- All ratings are based on applying the rated nominal power to the relay coil in such a manner as to provide a "clean" make and break, and does not result in any contact chatter or multiple actuation of the contacts.
- The tungsten rating is based on cold filament inrush current not exceeding 15 times the rated steady state lamp current.

**RELAY DIMENSIONS**

shown in inches (millimeters)

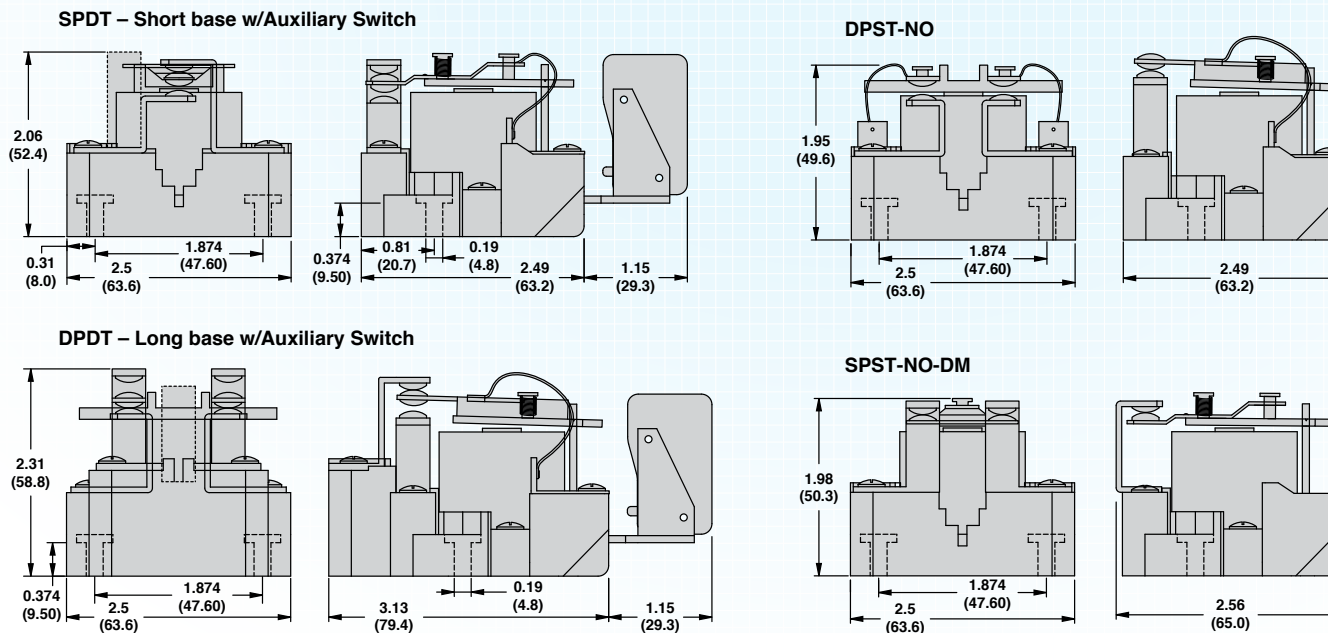

**RELAY WIRING DIAGRAMS**

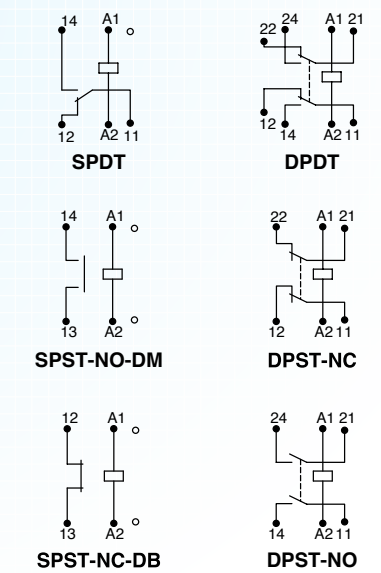

# Mouser Electronics

Authorized Distributor

Click to View Pricing, Inventory, Delivery & Lifecycle Information:

## Schneider Electric:

[199ABX-14](#) [199AX-4](#) [199AX-8](#) [199AX-9](#) [199AX-10](#) [199AX-13](#) [199AX-14](#) [199AX-15](#) [199BX-12](#) [199BX-13](#)  
[199BX-14](#) [199DX-2](#) [199DX-3](#) [199X-2](#) [199X-3](#) [199X-7](#) [199X-8](#) [199X-12](#) [199X-13](#) [199X-14](#) [199DBX-3](#) [199DBX-6](#)  
[199BX-7](#) [199ADBX-4](#) [199BMX-14](#)