

## 1090QA Series Non-Relampable Incandescent Indicator Lights

### Description and Features

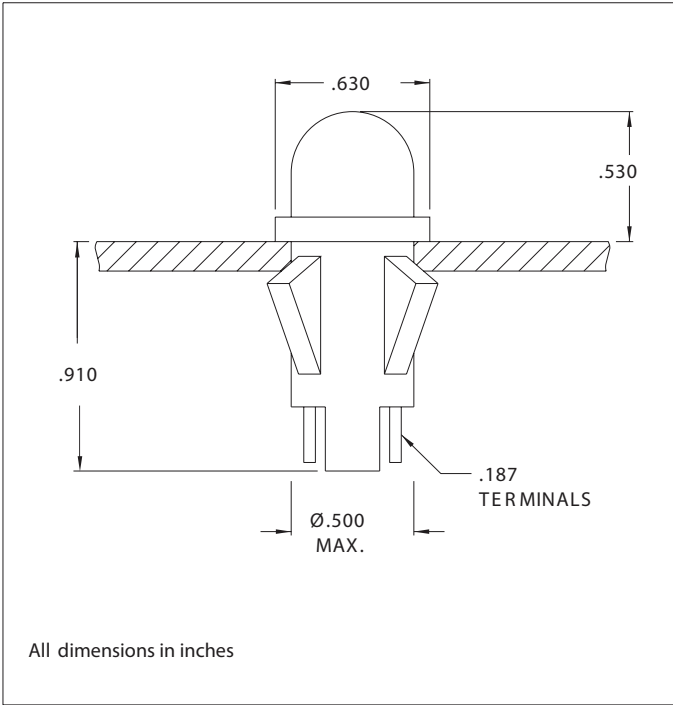

Mounting: Will snap-fit into Ø.500/.505 hole in panels  
.020/.100 thick. Push-on speednut SN0461  
also available. Mounting hole pattern on page SP2.

Terminals: Quick-connect, tinned brass

Lens: Polycarbonate

Bezel: Polished stainless steel.

Housing: White Nylon

Lens Color	Incandescent	
	Model No. (12V)	Model No. (28V)
Red	1090QA1-12V	1090QA1-28V
White	-	1090QA3-28V
White	-	1090QA4-28V
Green	1090QA5-12V	1090QA5-28V
Blue	-	1090QA6-28V
Lamp used	#2162	#2187

Underwriters Laboratories (UL) File No. E20356

# Mouser Electronics

Authorized Distributor

Click to View Pricing, Inventory, Delivery & Lifecycle Information:

VCC:

[1090QA5-28V](#) [1090QA3-28V](#) [1090QA5-12V](#) [1090QA1-12V](#) [1090QA1-28V](#) [1090QA4-28V](#) [1090QA6-28V](#)