

## Sleeve housing for cable connector - TU-0000000TUDU - 1605891

Please be informed that the data shown in this PDF Document is generated from our Online Catalog. Please find the complete data in the user's documentation. Our General Terms of Use for Downloads are valid (<http://phoenixcontact.com/download>)

Sleeve housing for cable connector, angled, Bayonet locking, M23, shielded: yes, Cable diameter: 2 mm...14.5 mm



### Key Commercial Data

|                                      |          |
|--------------------------------------|----------|
| Packing unit                         | 1 pc     |
| Weight per Piece (excluding packing) | 164.34 g |
| Custom tariff number                 | 85389099 |
| Country of origin                    | Germany  |

### Technical data

#### General

|                             |   |
|-----------------------------|---|
| Note                        | Order information: Order contact inserts separately |
| Type of locking             | Bayonet locking                                     |
| Contact connection method   | Crimp connection                                    |
| Type of contacts            | Socket  |
| Conductor entry             | 2 mm ... 14.5 mm                                    |
| Pg housing screw connection | none  |

#### Ambient conditions

|                      |                   |
|----------------------|-------------------|
| Ambient temperature  | -20 °C ... 125 °C |
| Degree of protection | IP67              |

#### Material

|                            |  |
|----------------------------|--|
| Housing material           | Turned parts: copper zinc alloy (CuZn), die-cast parts: zinc (GD-Zn) |
| Gasket and O-ring material | FPM  |

#### Specifications according to DIN EN 61984:2001

|                          |        |
|--------------------------|--------|
| Installation height max. | 2000 m |
|--------------------------|--------|

# Sleeve housing for cable connector - TU-0000000TUDU - 1605891

## Classifications

eCl@ss

|            |          |
|------------|----------|
| eCl@ss 4.0 | 272607xx |
| eCl@ss 4.1 | 27260701 |
| eCl@ss 5.0 | 27260701 |
| eCl@ss 5.1 | 27260701 |
| eCl@ss 6.0 | 27260708 |
| eCl@ss 7.0 | 27440312 |
| eCl@ss 8.0 | 27440202 |
| eCl@ss 9.0 | 27440202 |

ETIM

|          |          |
|----------|----------|
| ETIM 3.0 | EC001121 |
| ETIM 4.0 | EC000437 |
| ETIM 5.0 | EC000437 |

UNSPSC

|               |          |
|---------------|----------|
| UNSPSC 6.01   | 43172015 |
| UNSPSC 7.0901 | 43201404 |
| UNSPSC 11     | 43172015 |
| UNSPSC 12.01  | 43201404 |
| UNSPSC 13.2   | 43201404 |

## Drawings

Diagram

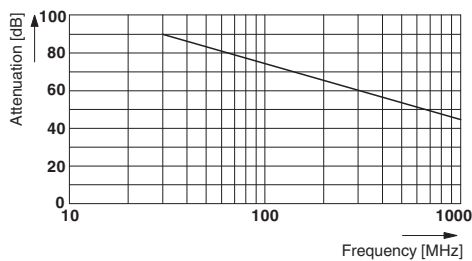

Dimensional drawing

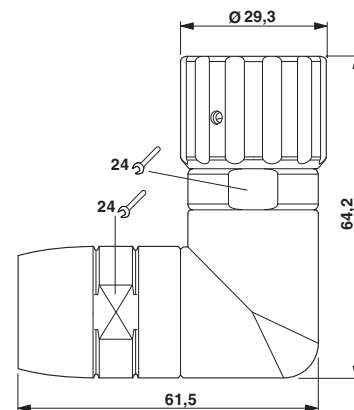



# Mouser Electronics

Authorized Distributor

Click to View Pricing, Inventory, Delivery & Lifecycle Information:

[Phoenix Contact:](#)

[1605891](#)