

PART NUMBER	REV	FIRST USED	POWER UNIT	FEED TYPE	DESCRIPTION
1852421-1	B	122500-1	LEADMAKER	POST FEED	CUTS CARRIER
1852421-2	B	565435-5	BENCH MODEL K	PRE FEED	CUTS CARRIER
1852421-3	B	354500-1	BENCH MODEL G	PRE FEED	CUTS CARRIER
1852421-6	B	122500-1	LEADMAKER	POST FEED	CONTINUOUS CARRIER
7-1852421-7	B	-	-	-	SPARE PARTS

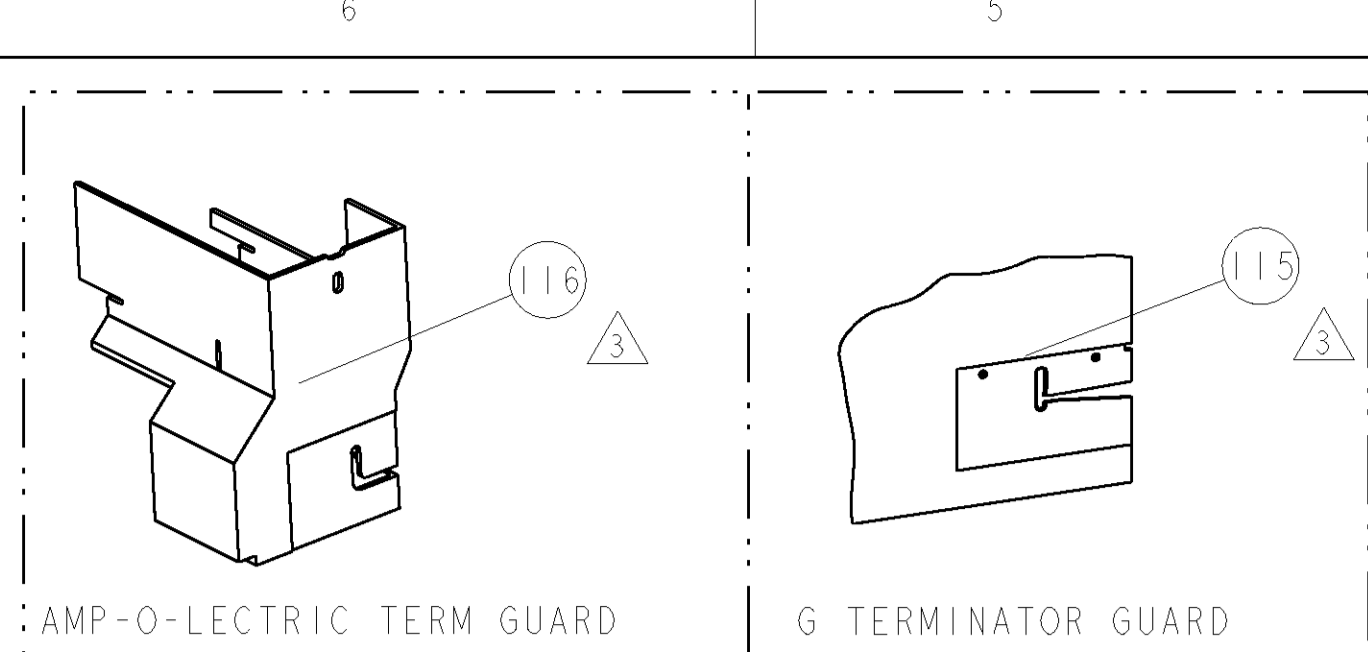

TE PN		MFR PN		MOLEX TERMINAL - AMP CRIMP SPECS	
1949249-1	-	98915-1029	-	CRIMP HEIGHT	WIRE SIZE
1949249-2	-	98915-1319	-	A 1.52±0.05mm [0.060±.002]	16AWG
1949249-3	-	64323-1029	-	B 1.32±0.05mm [0.052±.002]	18AWG
-	-	-	-	C 1.19±0.05mm [0.047±.002]	20AWG
-	-	-	-	D -	-
-	-	-	-	CRIMP	SIZE TYPE RANGE
-	-	-	-	WIRE	2.03mm [.080] F 20-16 AWG
-	-	-	-	INSUL	2.54mm [.100] O Ø1.60-2.05
WIRE STRIP LENGTH	TERM APPL SPEC	FEED	APPLICATOR INSTRUCTIONS	SET UP GAGE	
4.2-4.6mm	NONE	9.2mm	408-8040	458637-1	

LOC	DIST	REV	DESCRIPTION	DATE	OWN	APPR
A	66		RELEASED	19FEB2007	ROW	GB
		B	ECR-09-016293	20JUL2009	MY	TE

- △ RECOMMENDED SPARE PARTS
- △ GREASE LIGHTLY
- △ GUARD MUST BE IN PLACE WHEN OPERATING APPLICATOR IN A BENCH MACHINE
- △ APPLICATION NOT RECOMMENDED

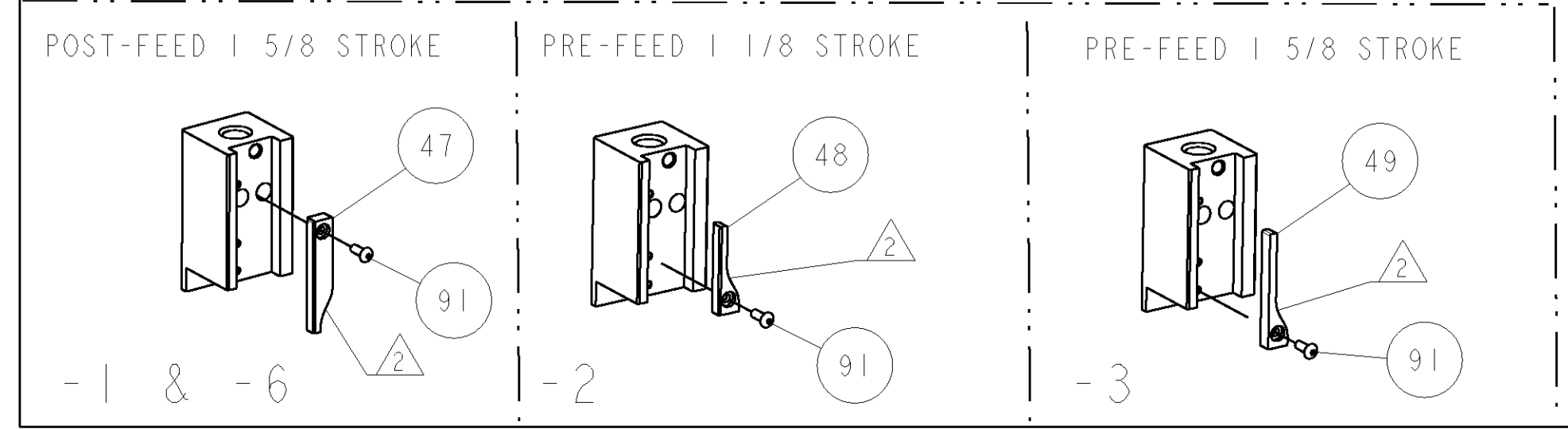
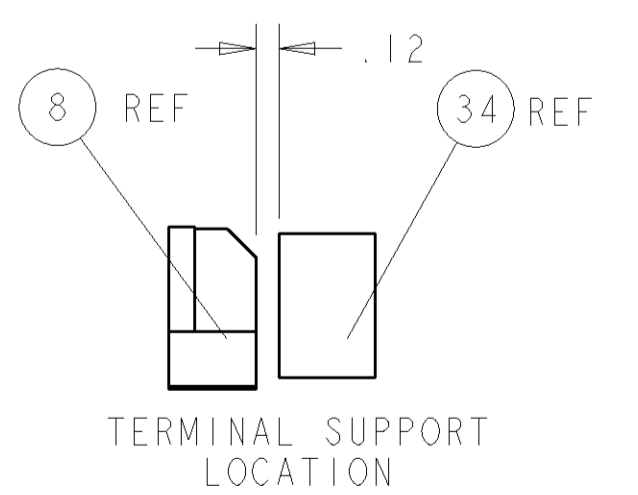
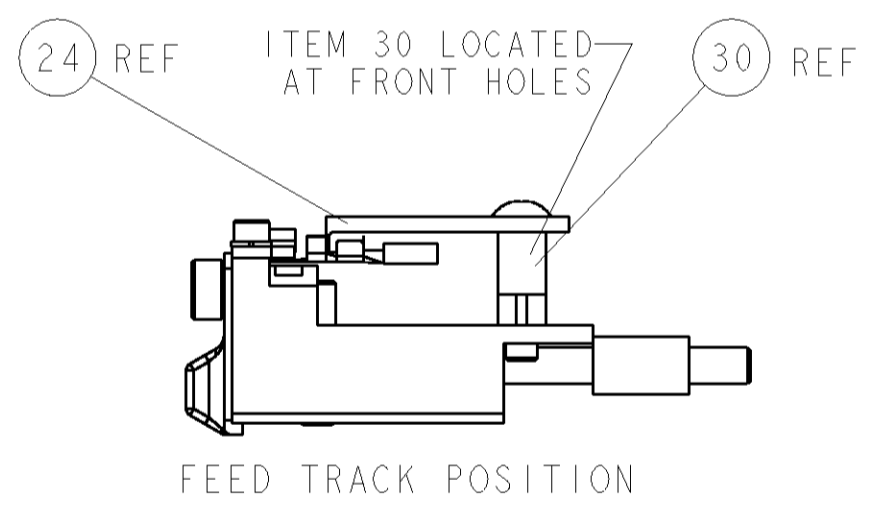
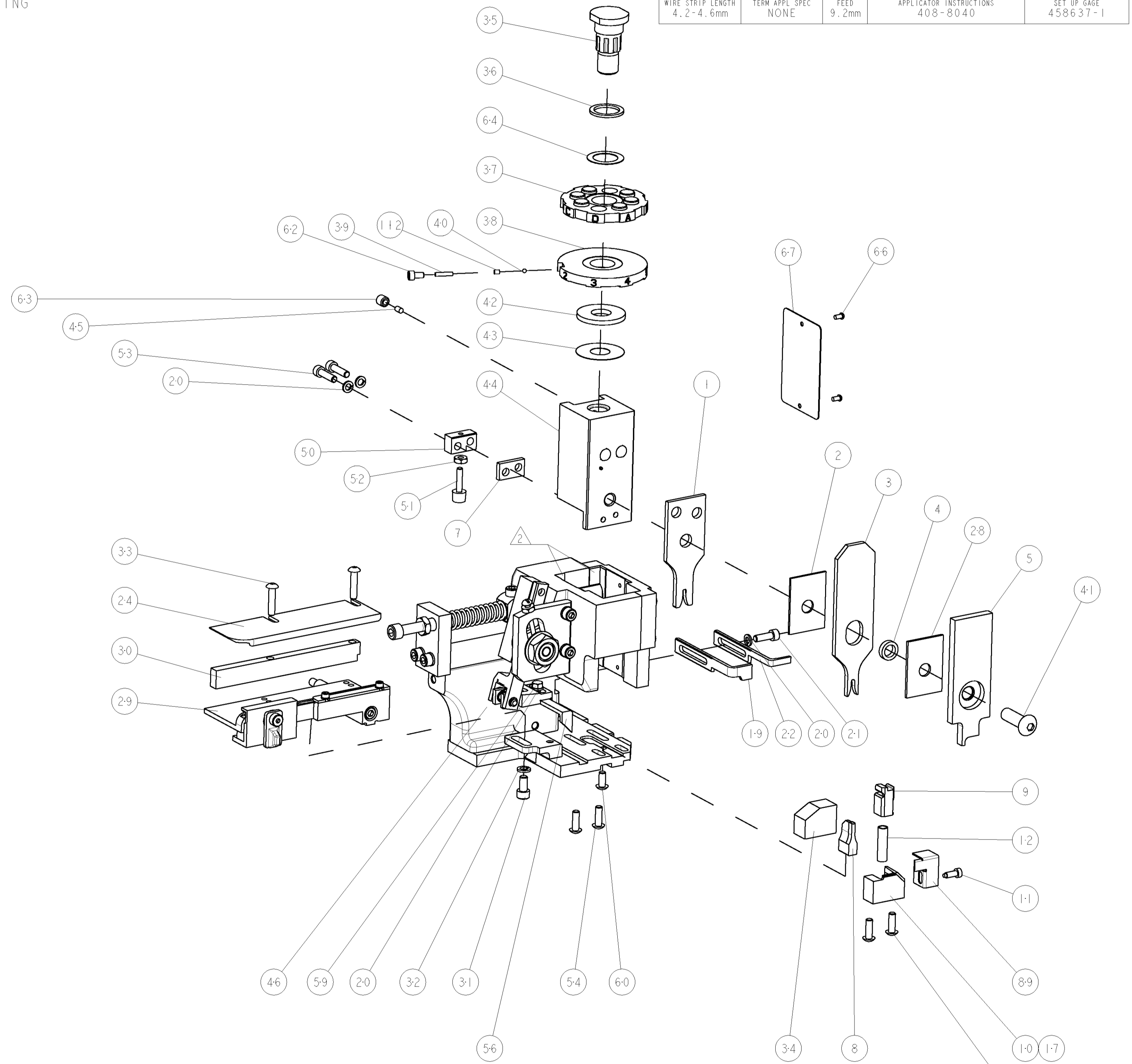
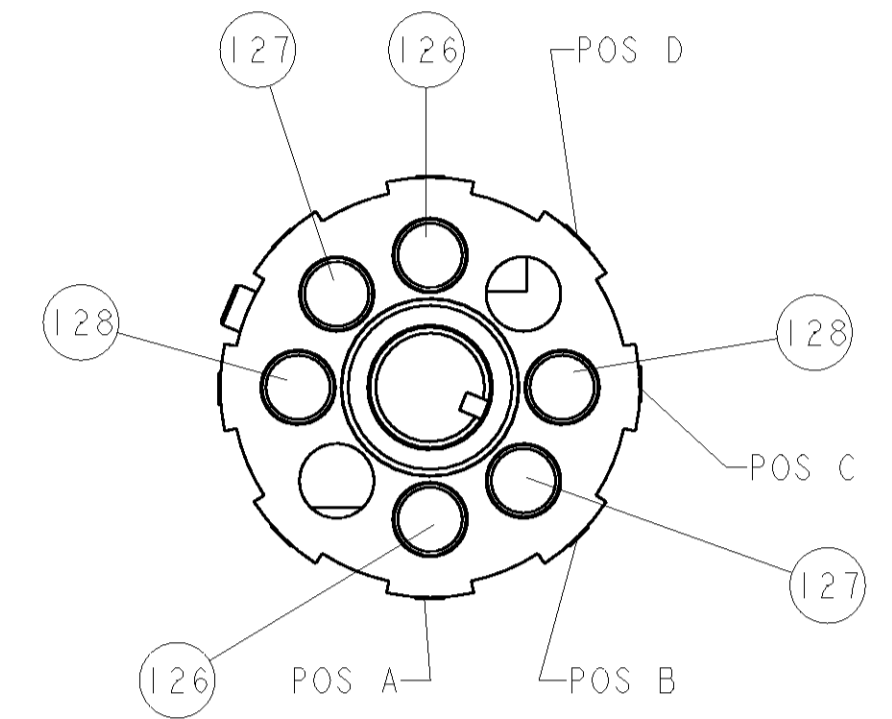

QTY	REV	DESCRIPTION	DATE	ITEM NO		
- 2	2	2	2	4-354779-4	PIN, WIRE DISC, .3210	128
- 2	2	2	2	3-354779-4	PIN, WIRE DISC, .3160	127
- 2	2	2	2	1-354779-6	PIN, WIRE DISC, .3070	126
-	-	REF	-	455749-1	GUARD WINDOW	116
-	-	REF	-	679532-1	INSERT, GUARD	115
-	1	1	1	690603-1	SPRING ASSIST AMP-O-MATOR APPLICATOR	112
-	1	1	1	1-21002-7	SCR, BTN SKT HD CAP 6-32 X .375	91
-	1	1	1	318563-1	GUARD, FRONT CHIP	89
-	1	1	1	4088040	SF APPL INST 408-8040	72
-	1	1	1	217238-1	GENERAL INSTRUCTION PKG	71
-	1	1	1	461264-1	PLATE, IDENTIFICATION	67
-	2	2	2	21017-2	SCREW, DRIVE	66
-	1	1	1	986950-1	WASHER, FLAT PRECISION	64
-	1	1	1	21009-2	SCR, SET, SELF LOCKING 1/4-20 X .250	63
-	1	1	1	23030-1	SCR, SKT HD CAP 6-32 X .25	62
-	1	1	1	22733-8	SCR, BHSC, SELF-LOCKING, 8-32 X .375	60
-	1	1	1	2-22603-0	SCR, HEX HD CAP 8-32 X .312	59
-	1	1	1	458537-2	PAWL, FEED	56
-	4	4	4	2-21002-2	SCR, BTN SKT HD CAP 8-32 X .500	54
-	2	2	2	2-21000-8	SCR, SKT HD CAP 8-32 X .625	53
-	1	1	1	21018-5	NUT, HEX, REG 6-32	52
-	1	1	1	811242-2	BUMPER, HOLD DOWN	51
-	1	1	1	690753-1	SPACER, TONKER	50
-	-	1	-	690602-6	CAM, PRE FEED, 1 5/8	49
-	-	1	-	690602-5	CAM, PRE FEED, 1 1/8	48
-	1	1	1	690501-4	CAM, POST-FEED 1 5/8	47
-	1	1	1	459456-1	APPL. BASIC SUB ASSY (SIDE WISE MQCA)	46
-	1	1	1	690191-1	PLUG, NYLON	45
-	1	1	1	455673-1	RAM, SIDE FEED	44
-	1	1	1	690125-1	SHIM SUB-ASSY	43
-	1	1	1	690124-1	WASHER, RAM (.115)	42
-	1	1	1	7-21002-9	SCR, BTN SKT HD CAP 5/16-24 X 1.00	41
-	1	1	1	23241-6	BALL, STEEL	40
-	1	1	1	690170-1	SPRING, COMPRESSION	39
-	1	1	1	690142-1	DISC, INSULATION	38
-	1	1	1	354777-1	WIRE DISC, ASSEMBLY	37
-	1	1	1	22480-5	SPRING, COMPRESSION	36
-	1	1	1	690212-1	POST, RAM	35
-	1	1	1	690786-6	TERMINAL SUPPORT	34
-	2	2	2	2-21002-4	SCR, BTN SKT HD CAP 8-32 X .750	33
-	1	1	1	21024-5	WASHER, SPRG LOCK, REG NO 10	32
-	1	1	1	3-21000-4	SCR, SKT HD CAP 10-32 X .375	31
-	1	1	1	1-1320908-5	SPACER, STRIP GUIDE	30
-	1	1	1	1633091-1	ASSEMBLY, STRIP GUIDE	29
-	1	1	1	1-455888-4	SPACER, CRIMPER	28
-	1	1	1	1320928-1	PLATE, STRIP GUIDE	24
-	1	1	1	690472-2	STRIPPER	22
-	1	1	1	2-21000-7	SCR, SKT HD CAP 8-32 X .500	21
-	4	4	4	21024-4	WASHER, SPRG LOCK, REG NO 8	20
-	-	1	-	691353-1	STRIPPER	19
-	1	1	1	679625-1	SHEAR HOLDER, FRONT (NO CUT)	17
-	1	1	1	3-22280-3	SPRING, COMPRESSION	12
-	1	1	1	690461-1	STOP, SHEAR	11
-	-	1	-	690459-1	SHEAR HOLDER, FRONT	10
-	1	1	1	454276-1	FLOATING SHEAR, FRONT	9
1	1	1	1	7-1633117-2	ANVIL, COMBINATION	8
-	1	1	1	240641-5	SPACER	7
-	1	1	1	1-455889-4	DEPRESSOR, SHEAR	5
-	1	1	1	238011-2	BLOCK, CRIMPER SPACER	4
1	1	1	1	4-456135-8	CRIMPER, INSULATION O PREMIUM	3
-	1	1	1	1-455888-0	SPACER, CRIMPER	2
1	1	1	1	1-456405-5	CRIMPER, WIRE PREMIUM	1

DIMENSIONS: INCHES		TOLERANCES UNLESS OTHERWISE SPECIFIED:		DWN R. O. WILSON 05FEB2007		Tyco Electronics Tyco Electronics Harrisburg, PA 17105-3608	
Ø	9 PLC ±.01	1 PLC ±.01	3 PLC ±.001	4 PLC ±.0001	APPR T. ELBIN 06FEB2007	NAME PRODUCT SPEC	
MATERIAL	FINISH	WEIGHT	SIZE	CAGE CODE	DRAWING NO	RESTRICTED TO	
-	-	-	A1	00779	1852421	SCALE	3:5 SHEET 1 OF 1 REV B

CUSTOMER ACCESSIBLE PRODUCTION DRAWING