

LOC	DIST	REVISIONS					
GP	00	P	LTN	DESCRIPTION	DATE	DMN	APVD
		C		REVISED PER ECO-11-020849	11JAN2011	CJV	PAR
		C1		REVISED PER ECO-13-003678	09APR2013	CJV	PAR

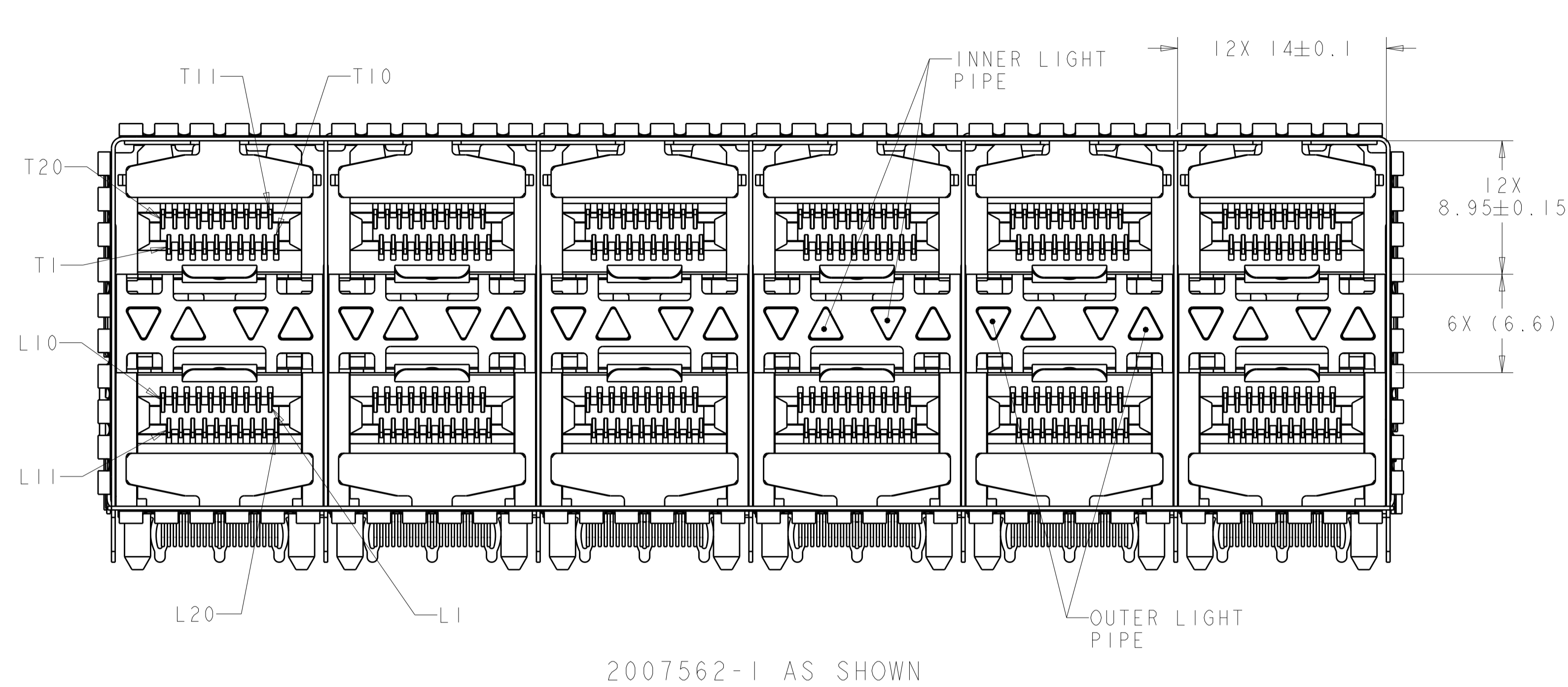

2007562-1 AS SHOWN

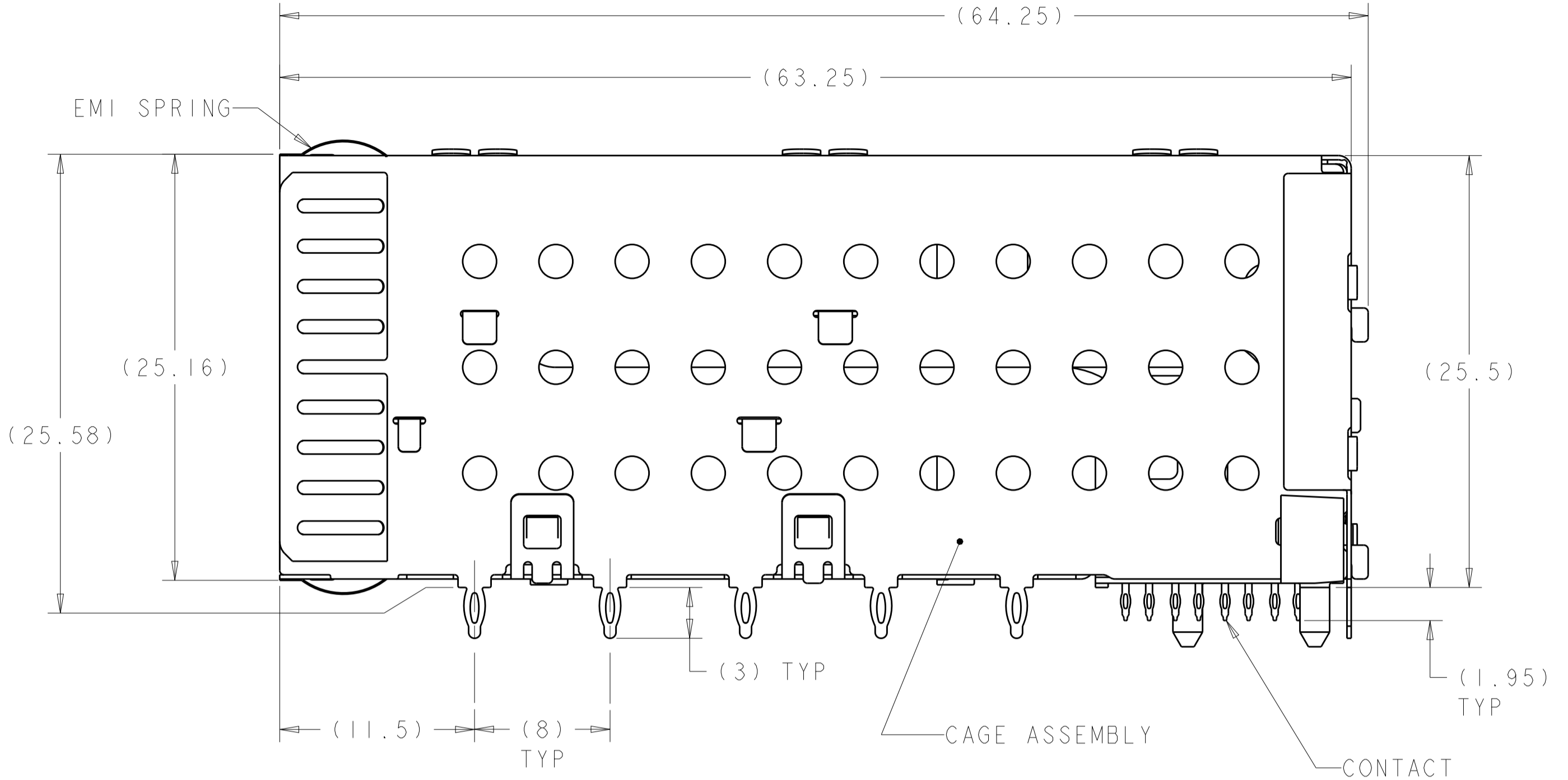

- △ MATERIALS:
 CAGE ASSEMBLY- NICKEL SILVER ALLOY PER ASTM B 122.
 EMI SPRING- COPPER ALLOY.
 HOUSING- BLACK LCP, UL 94V-0 RATED.
 CHICKLET- BLACK LCP, UL 94V-0 RATED.
 LIGHT PIPE- POLYCARBONATE, CLEAR.
 INSERT- PBT, BLACK, UL 94V-0.
 CONTACT- COPPER ALLOY.
- △ DATUM AND BASIC DIMENSIONS ESTABLISHED BY CUSTOMER.
- 3. MINIMUM PCB THICKNESS OF 1.5.
- △ CONTACT FINISH- CONFORMS TO THE REQUIREMENTS OF TYCO ELECTRONICS PRODUCT SPECIFICATION 108-2331, BASED ON EIA/ECA-364-1000.01A, (CONTROLLED ENVIRONMENT APPLICATIONS) ON MATING INTERFACE, TIN-LEAD ON NEEDLE EYE.
- △ CONTACT FINISH- CONFORMS TO THE REQUIREMENTS OF TYCO ELECTRONICS PRODUCT SPECIFICATION 108-2331 BASED ON EIA/ECA-364-1000.01A, (CONTROLLED ENVIRONMENT APPLICATIONS) ON MATING INTERFACE, TIN ON NEEDLE EYE.
- △ FOR HOLE SIZE AND PLATINGS, SEE APPLICATION SPEC 114-13219.
- △ THE ENTIRE AREA OF THE CONNECTOR FOOTPRINT, INDICATED BY THE DASHED LINE, TO BE CONSIDERED THE KEEPOUT AREA FOR COMPONENTS AND SIGNAL TRACES, TOP SIDE ONLY. TOP SIDE TRACES ALLOWED WITHIN CONNECTOR HOLE PATTERN.
- △ LIGHT PIPE PAD LAYOUT IS FOR 0805 LOW PROFILE LED PACKAGE WITH A HEIGHT OF 0.8mm.
- △ EMI SPRING FINISH: 0.8µm MINIMUM MATTE TIN OVER 0.8µm MINIMUM NICKEL, NONPLATED EDGES PERMISSIBLE.
- △ ADDITIONAL COMPONENT LOCATED WITHIN LATCH PLATE FOR EMI SUPPRESSION.

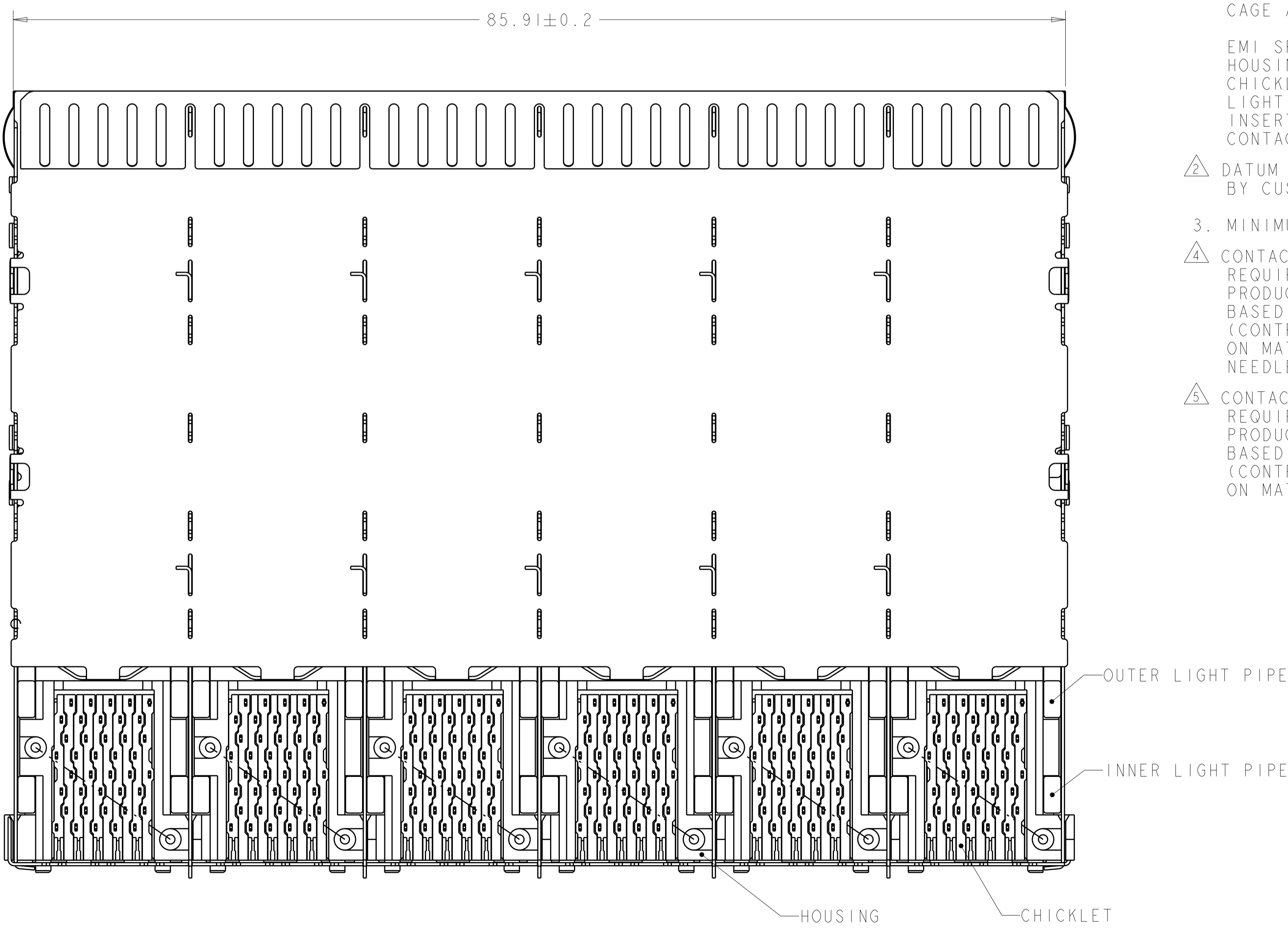

ENHANCED EMI	FINISH	DESCRIPTION	PART NUMBER
YES △10	△5	NO LIGHT PIPES	1-2007562-8
		OUTER 2 LIGHT PIPES	1-2007562-7
		INNER 2 LIGHT PIPES	1-2007562-6
NO	△5	4 LIGHT PIPES	1-2007562-5
		NO LIGHT PIPES	2007562-8
		OUTER 2 LIGHT PIPES	2007562-7
NO	△4	INNER 2 LIGHT PIPES	2007562-6
		4 LIGHT PIPES	2007562-5
		NO LIGHT LIGHT PIPES	2007562-4
		OUTER 2 LIGHT PIPES	2007562-3
		INNER 2 LIGHT PIPES	2007562-2
		4 LIGHT PIPES	2007562-1

THIS DRAWING IS A CONTROLLED DOCUMENT. DIMENSIONING AND TOLERANCING PER ASME Y14.5M-2009.

DMN: M. SHIRK 14JAN2008
 CHK: D. SZCZESNY 14JAN2008
 APVD: D. SZCZESNY 14JAN2008

PRODUCT SPEC: 108-2331
 APPLICATION SPEC: 114-13219

WEIGHT: -
 CUSTOMER DRAWING

SCALE: 4:1 SHEET 1 OF 4 REV: C1

STE TE Connectivity
 NAME: CAGE AND PT CONNECTOR ASSEMBLY, WITH EMI SPRINGS, PRESS FIT, 2X6, STACKED SFP+
 SIZE: A100779 C=2007562

LOC		DIST		REVISIONS			
GP	00	P	LYR	DESCRIPTION	DATE	DWN	APVD
				SEE SHEET 1			

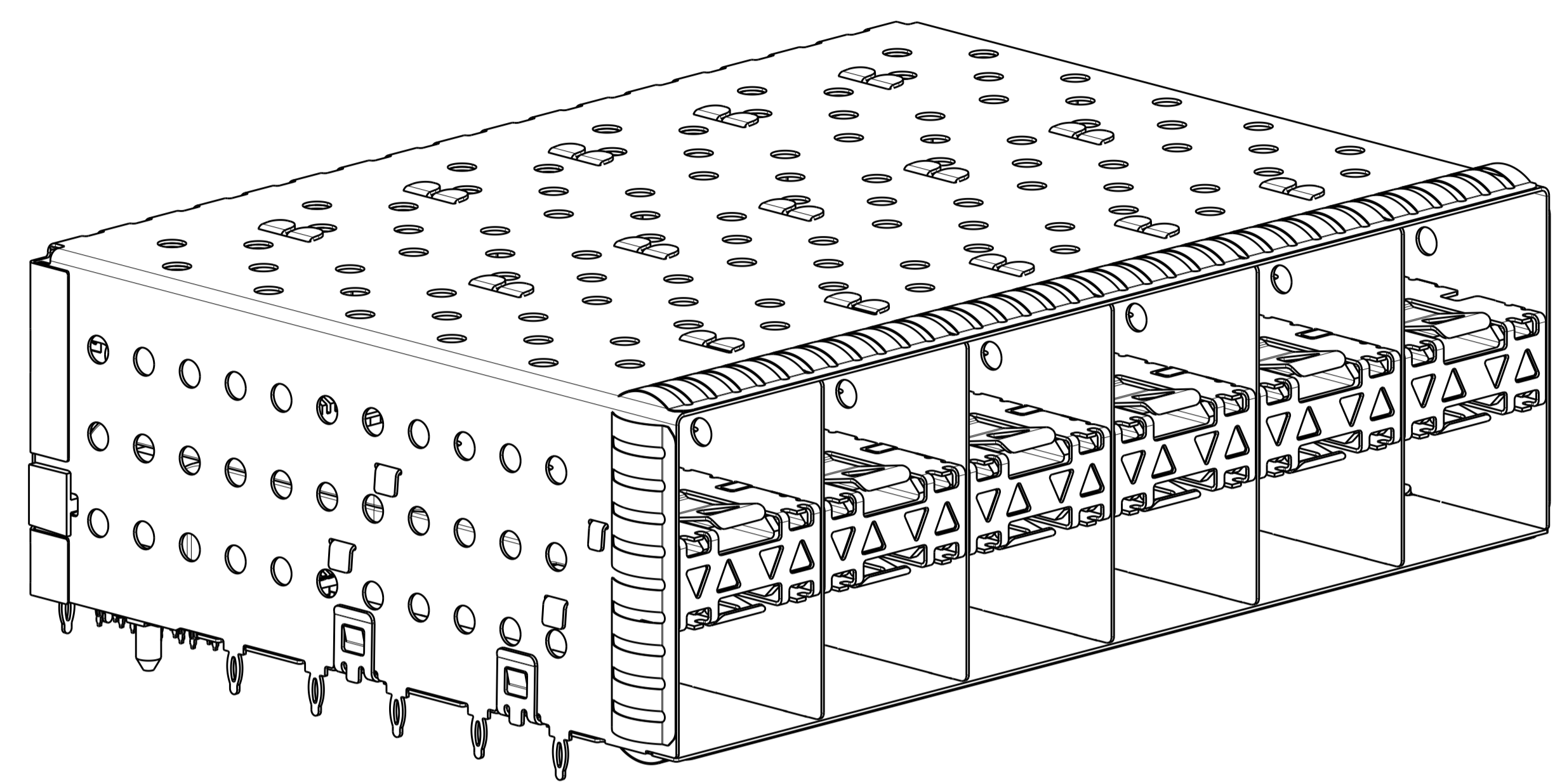

2007562-1, 2007562-5 AND 1-2007562-5
 SCALE 3:1

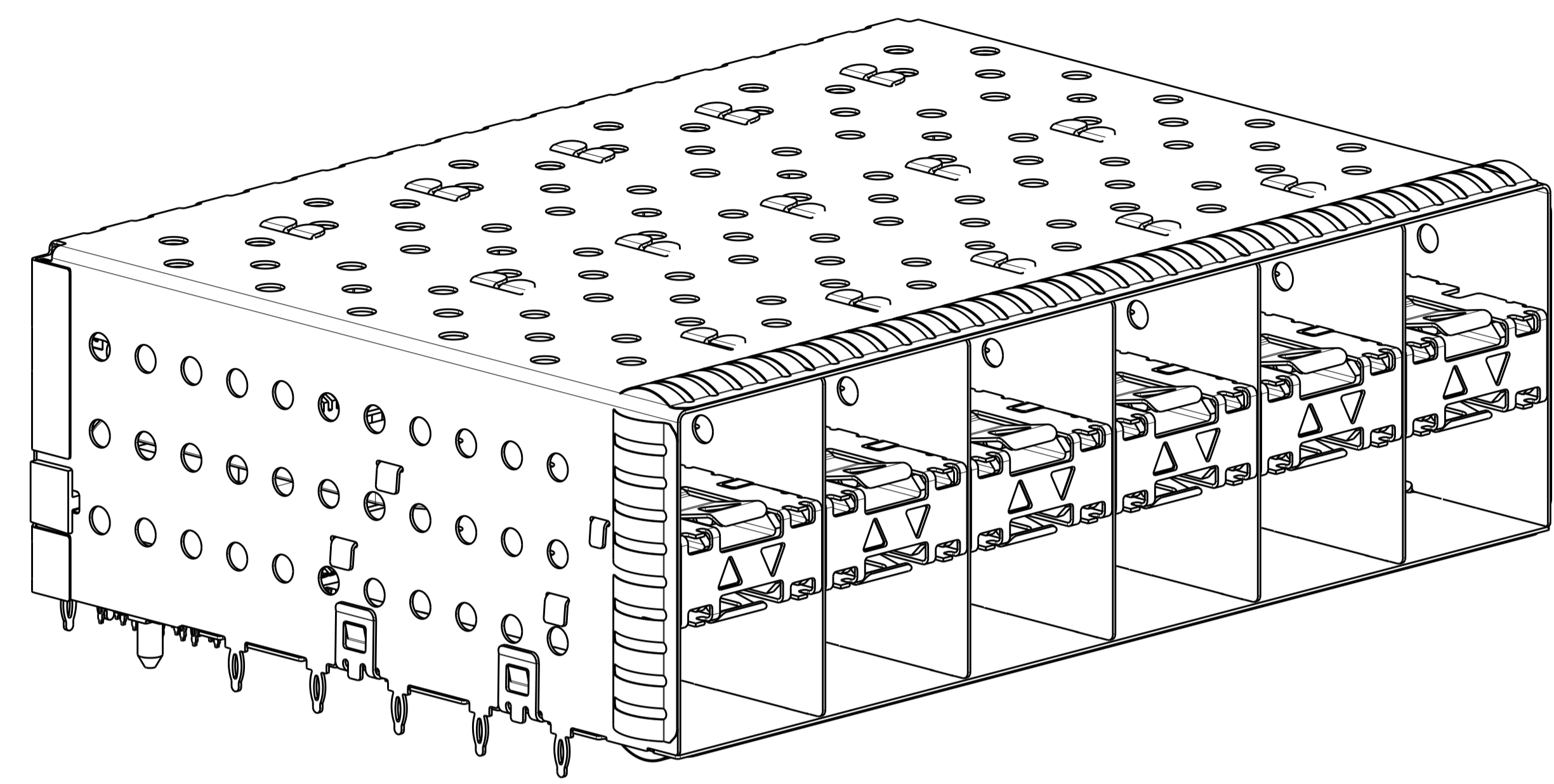

2007562-2, 2007562-6 AND 1-2007562-6
 SCALE 3:1

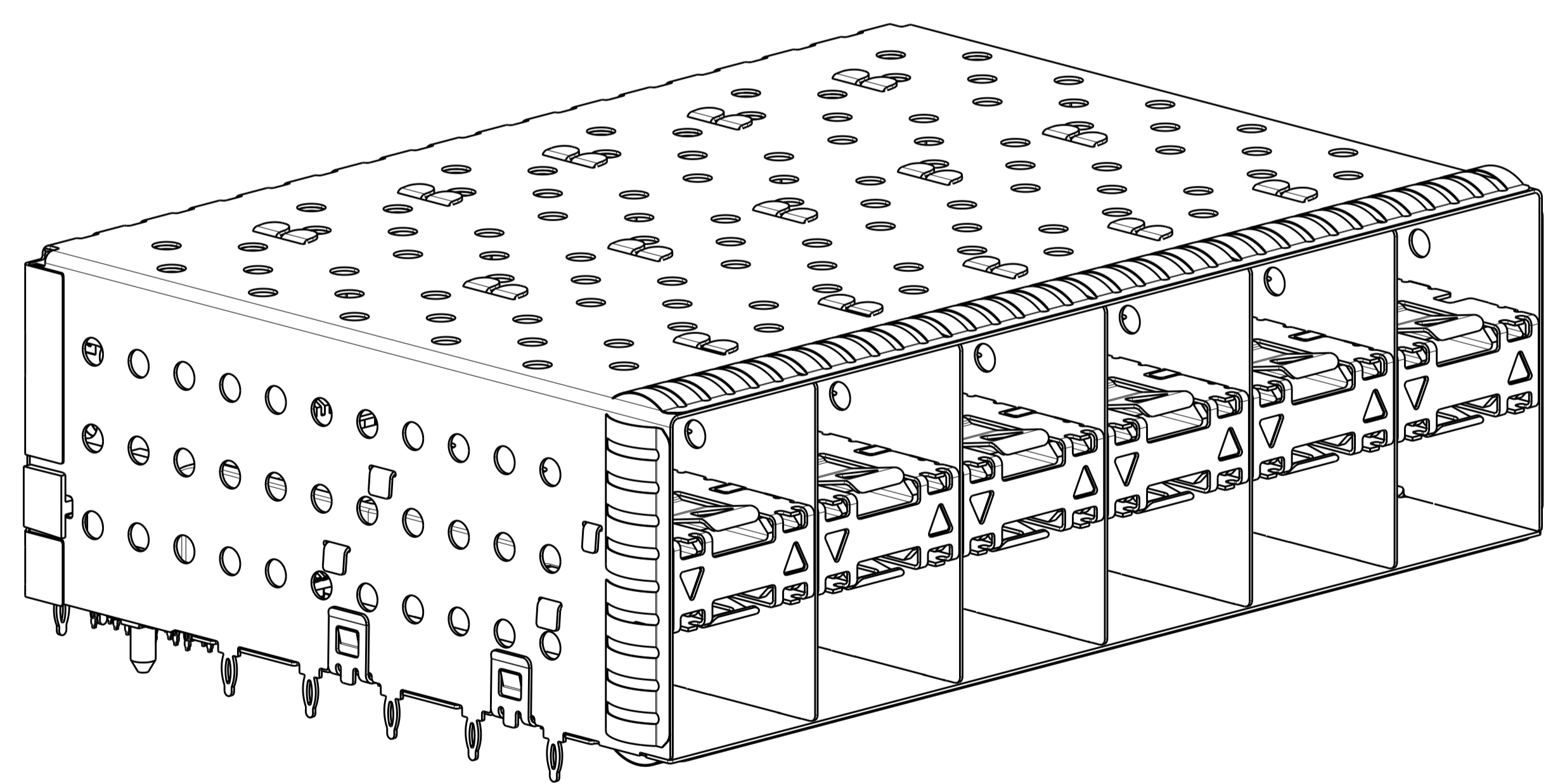

2007562-3, 2007562-7 AND 1-2007562-7
 SCALE 3:1

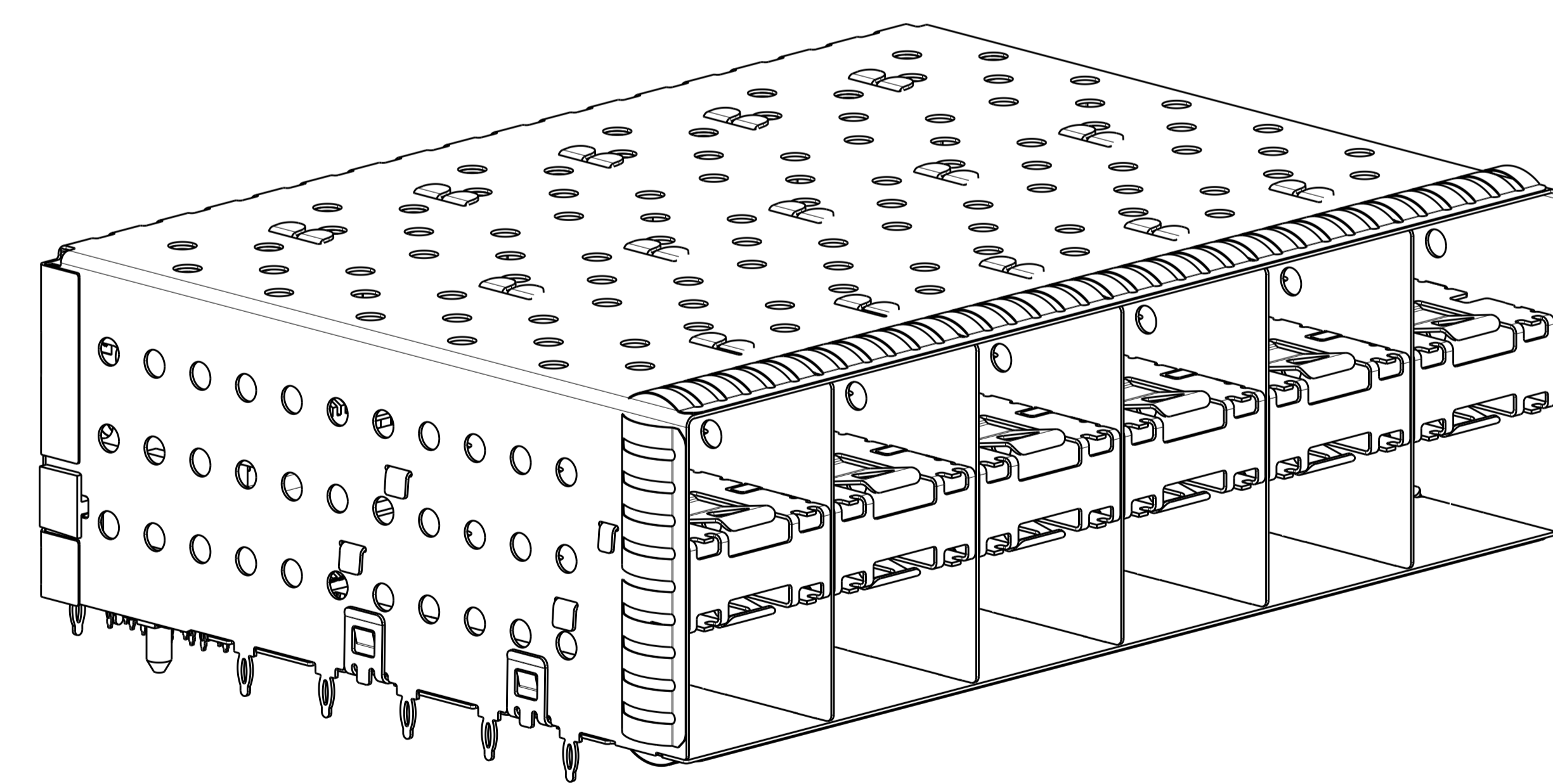

2007562-4, 2007562-8 AND 1-2007562-8
 SCALE 3:1

THIS DRAWING IS A CONTROLLED DOCUMENT. DIMENSIONING AND TOLERANCING PER ASME Y14.5M-2009		DWN M. SHIRK 14JAN2008	TE Connectivity NAME CAGE AND PT CONNECTOR ASSEMBLY, WITH EMI SPRINGS, PRESS FIT, 2X6, STACKED SFP+
DIMENSIONS: mm		CHK D. SZCZESNY 14JAN2008	
TOLERANCES UNLESS OTHERWISE SPECIFIED:		APVD D. SZCZESNY 14JAN2008	PRODUCT SPEC
0 PLC	±0.10	108-2331	APPLICATION SPEC
1 PLC	±0.10	114-13219	SIZE
2 PLC	±0.10	114-13219	CAGE CODE
3 PLC	±0.10	114-13219	DRAWING NO
4 PLC	±0.10	114-13219	RESTRICTED TO
ANGLES	±°	114-13219	A100779C=2007562
MATERIAL	FINISH	WEIGHT	SCALE 4:1 SHEET 2 OF 4 REV C1
CUSTOMER DRAWING			

LOC	DIST	REVISIONS			
P	LTN	DESCRIPTION	DATE	DWN	APVD
-	-	SEE SHEET 1	-	-	-

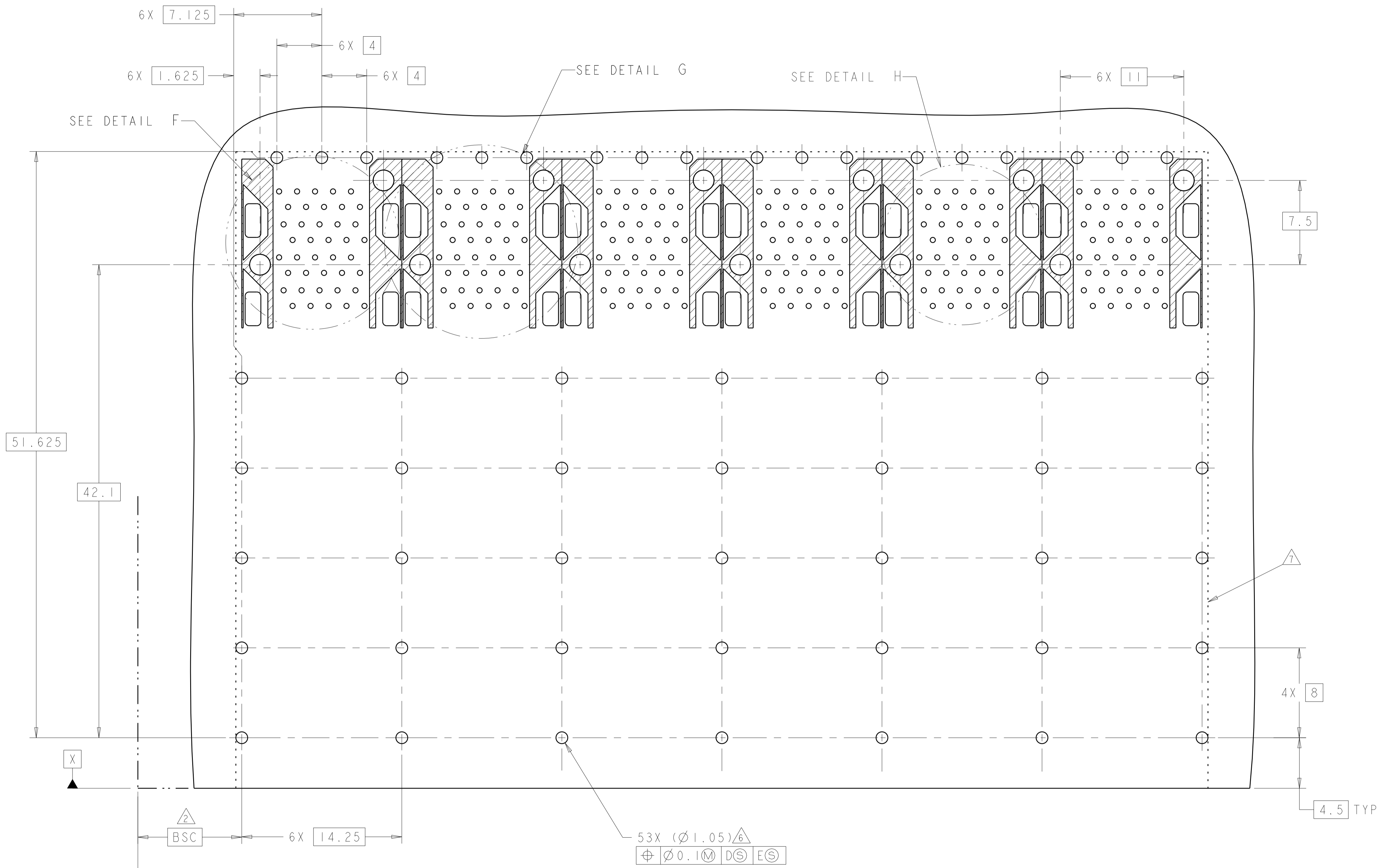

RECOMMENDED PCB LAYOUT
COMPONENT SIDE OF BOARD
SCALE 5:1

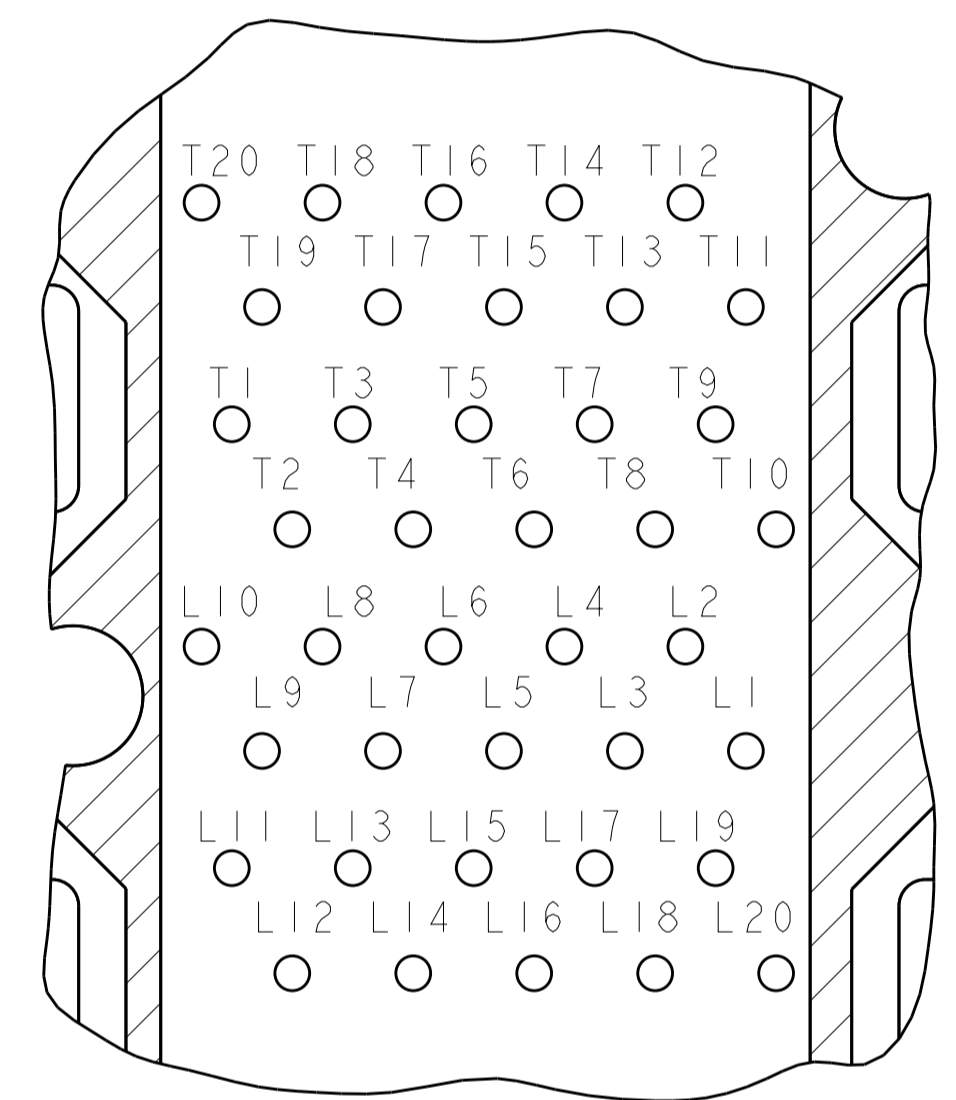

DETAIL H
CONNECTOR PIN-OUT
COMPONENT SIDE OF BOARD
6X INDIVIDUALLY
SCALE 10:1

THIS DRAWING IS A CONTROLLED DOCUMENT. DIMENSIONING AND TOLERANCING PER ASME Y14.5M-2009.		DWN: M. SHIRK 14JAN2008	TE Connectivity
DIMENSIONS: mm		CHK: D. SZCZESNY 14JAN2008	
TOLERANCES UNLESS OTHERWISE SPECIFIED:		APVD: D. SZCZESNY 14JAN2008	NAME: CAGE AND PT CONNECTOR ASSEMBLY, WITH EMI SPRINGS, PRESS FIT, 2X6, STACKED SFP+
0 PLC ±0.10		PRODUCT SPEC: 108-2331	
1 PLC ±0.10		APPLICATION SPEC: 114-13219	SIZE: A100779 C=2007562
2 PLC ±0.10		WEIGHT: -	
3 PLC ±0.10		FINISH: -	RESTRICTED TO: -
4 PLC ±0.10		MATERIAL: -	SCALE: 4:1 SHEET 3 OF 4 REV: C1
ANGLES: ±°		CUSTOMER DRAWING	

LOC	DIST	REVISIONS			
GP	00	REV	DATE	BY	APPV
		1	SEE SHEET 1		

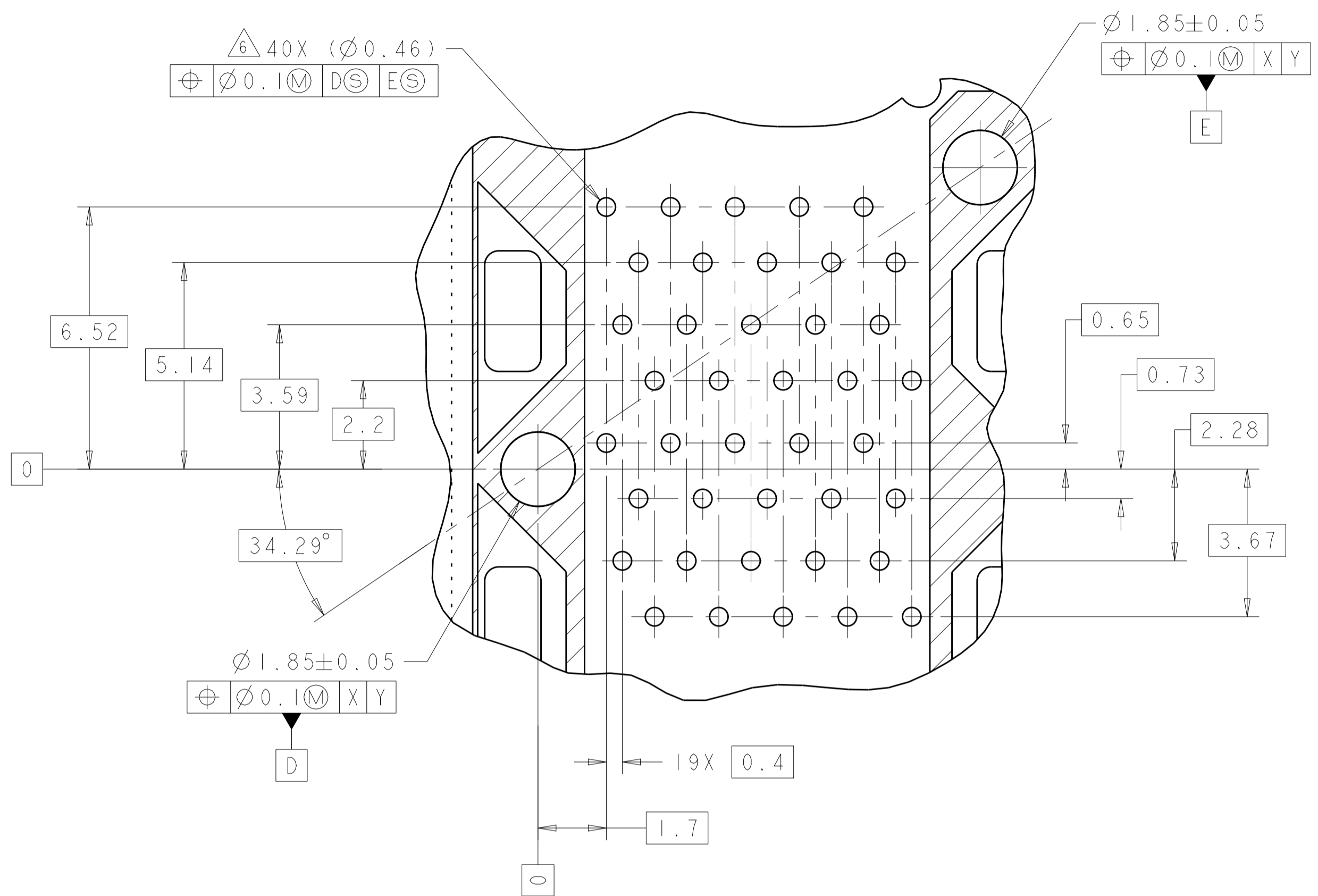

DETAIL F
 6X INDIVIDUALLY
 SCALE 10:1

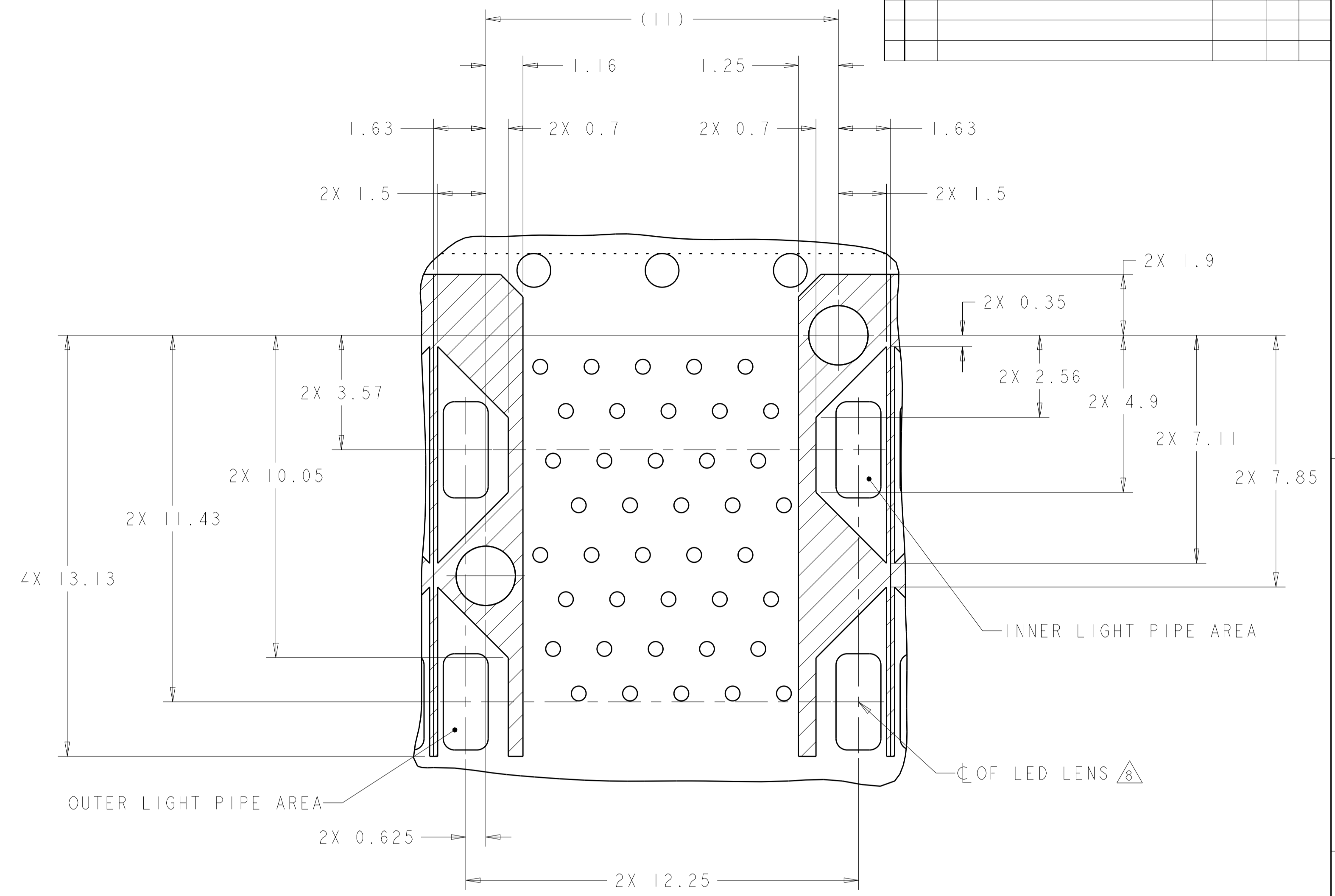

DETAIL G
 CONNECTOR HOUSING
 KEEPOUT ZONE
 6X INDIVIDUALLY
 SCALE 10:1

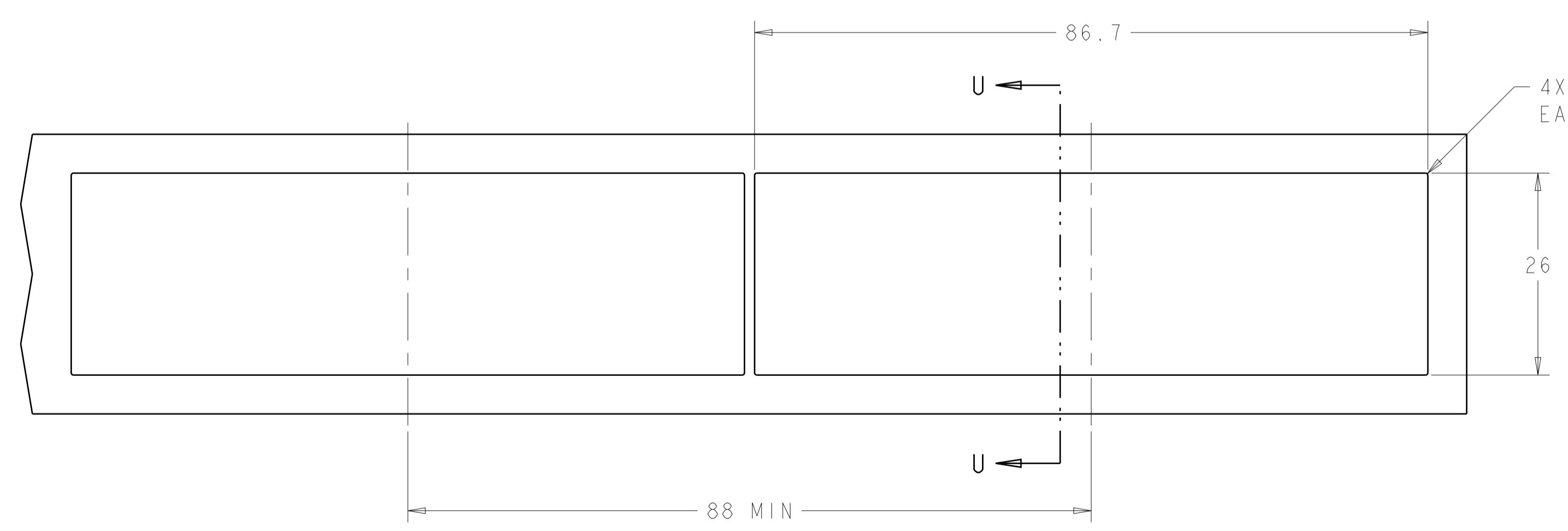

RECOMMENDED PANEL CUTOUT
 AND PC BOARD, PANEL POSITION
 SCALE 2:1

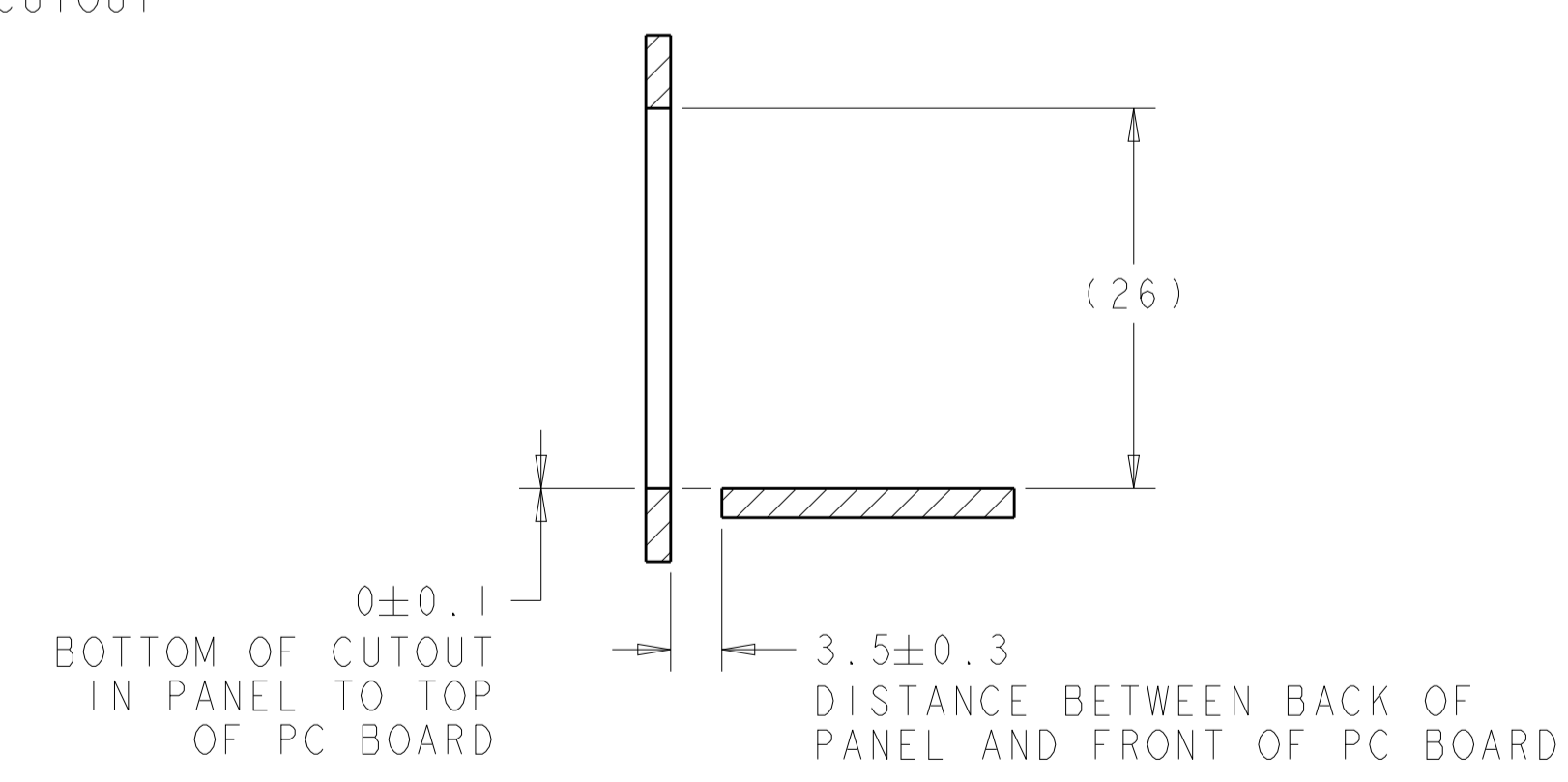

SECTION U-U

THIS DRAWING IS A CONTROLLED DOCUMENT. DIMENSIONING AND TOLERANCING PER ASME Y14.5M-2009.		OWN: M. SHIRK 14JAN2008	TE Connectivity NAME: CAGE AND PT CONNECTOR ASSEMBLY, WITH EMI SPRINGS, PRESS FIT, 2X6, STACKED SFP+
DIMENSIONS: mm		CHK: D. SZCZESNY 14JAN2008	
TOLERANCES UNLESS OTHERWISE SPECIFIED:		APV: D. SZCZESNY 14JAN2008	PRODUCT SPEC
0 PLC	±0.10	108-2331	APPLICATION SPEC
1 PLC	±0.10	114-13219	SIZE: CAGE CODE DRAWING NO
2 PLC	±0.10		RESTRICTED TO
3 PLC	±0.10		A100779C=2007562
4 PLC	±0.10		
ANGLES	±°		
MATERIAL	FINISH	WEIGHT	
CUSTOMER DRAWING		SCALE: 4:1	SHEET 4 OF 4 REV: C1

Mouser Electronics

Authorized Distributor

Click to View Pricing, Inventory, Delivery & Lifecycle Information:

[TE Connectivity:](#)

[1-2007562-6](#)