

PART NUMBER	REV	FIRST USED	POWER UNIT	FEED TYPE	DESCRIPTION
1852277-1	A	122500-1	LEADMAKER	POST FEED	CUTS CARRIER
1852277-2	A	565435-5	BENCH MODEL K	PRE FEED	CUTS CARRIER
1852277-3	A	354500-1	BENCH MODEL G	PRE FEED	CUTS CARRIER
1852277-6	A	122500-1	LEADMAKER	POST FEED	CONTINUOUS CARRIER
7-1852277-7	A	-	-	-	SPARE PARTS

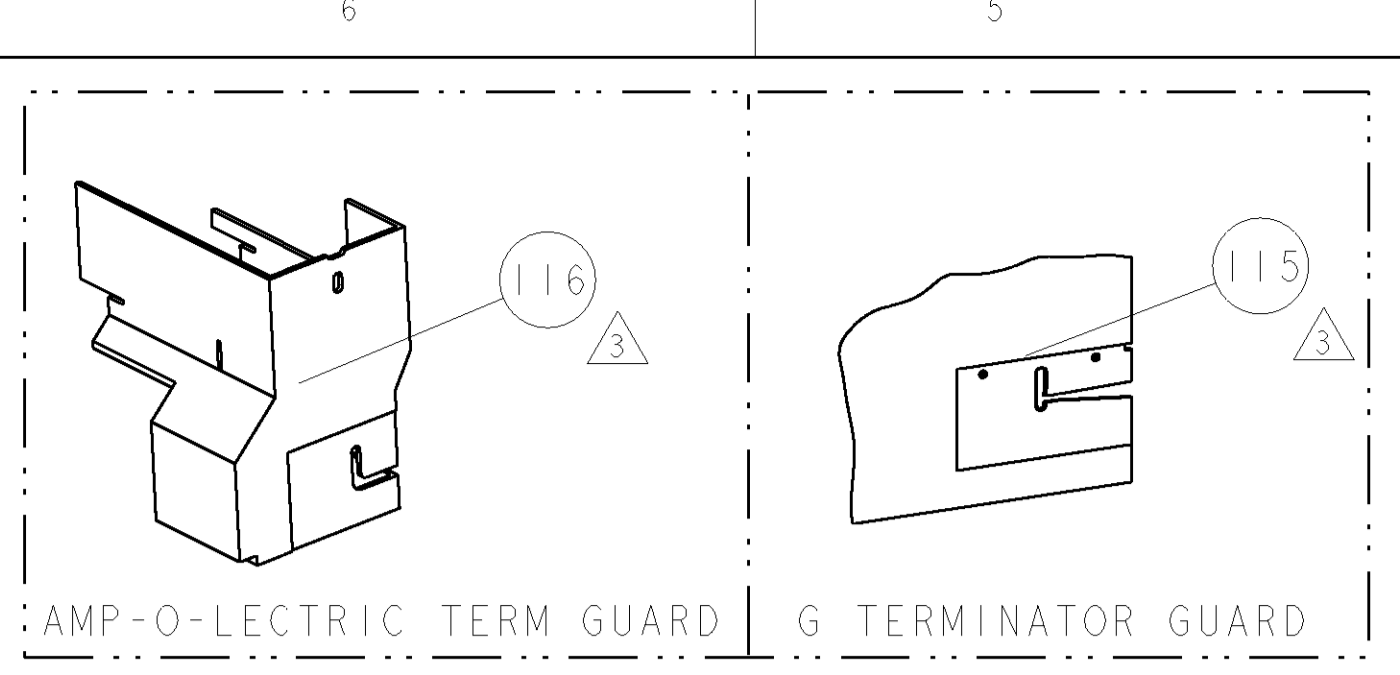

TYCO PN		COMP PN		SOUORIAU TERMINAL - AMP CRIMP SPECS	
1949067-1	-	SC20M-ITK6	-		
-	-	PAD LTR	-	CRIMP HEIGHT	WIRE SIZE
-	-	A	-	.043±.002[1.09±0.05mm]	20 AWG
-	-	B	-	.039±.002[.99±0.05mm]	22 AWG
-	-	C	-	.036±.002[.91±0.05mm]	24 AWG
-	-	D	-	-	-
-	-	CRIMP	SIZE	TYPE	RANGE
-	-	WIRE	.062 [1.57mm]	O	24-20 AWG
-	-	INSUL	.100 [2.54mm]	O	.080 MAX
WIRE STRIP LENGTH	TERM APPL SPEC	FEED	APPL INSTRUCTIONS	SET UP GAGE	
.138 - .153	NONE	.350	408-8040	458637-1	

LOC	DIST	P LTR	DESCRIPTION	DATE	DWN	APPR
A	66		RELEASED	06JUN2006	BH	BH

- △ RECOMMENDED SPARE PARTS
- △ GREASE LIGHTLY
- △ GUARD MUST BE IN PLACE WHEN OPERATING APPLICATOR IN A BENCH MACHINE

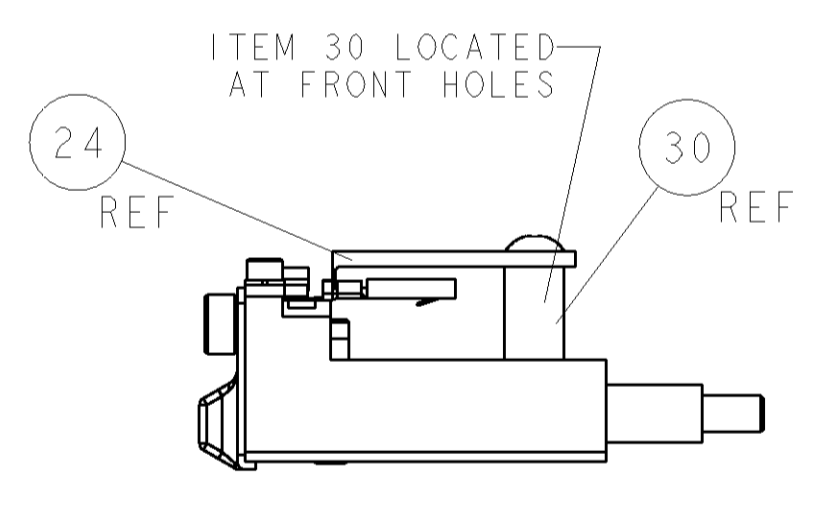
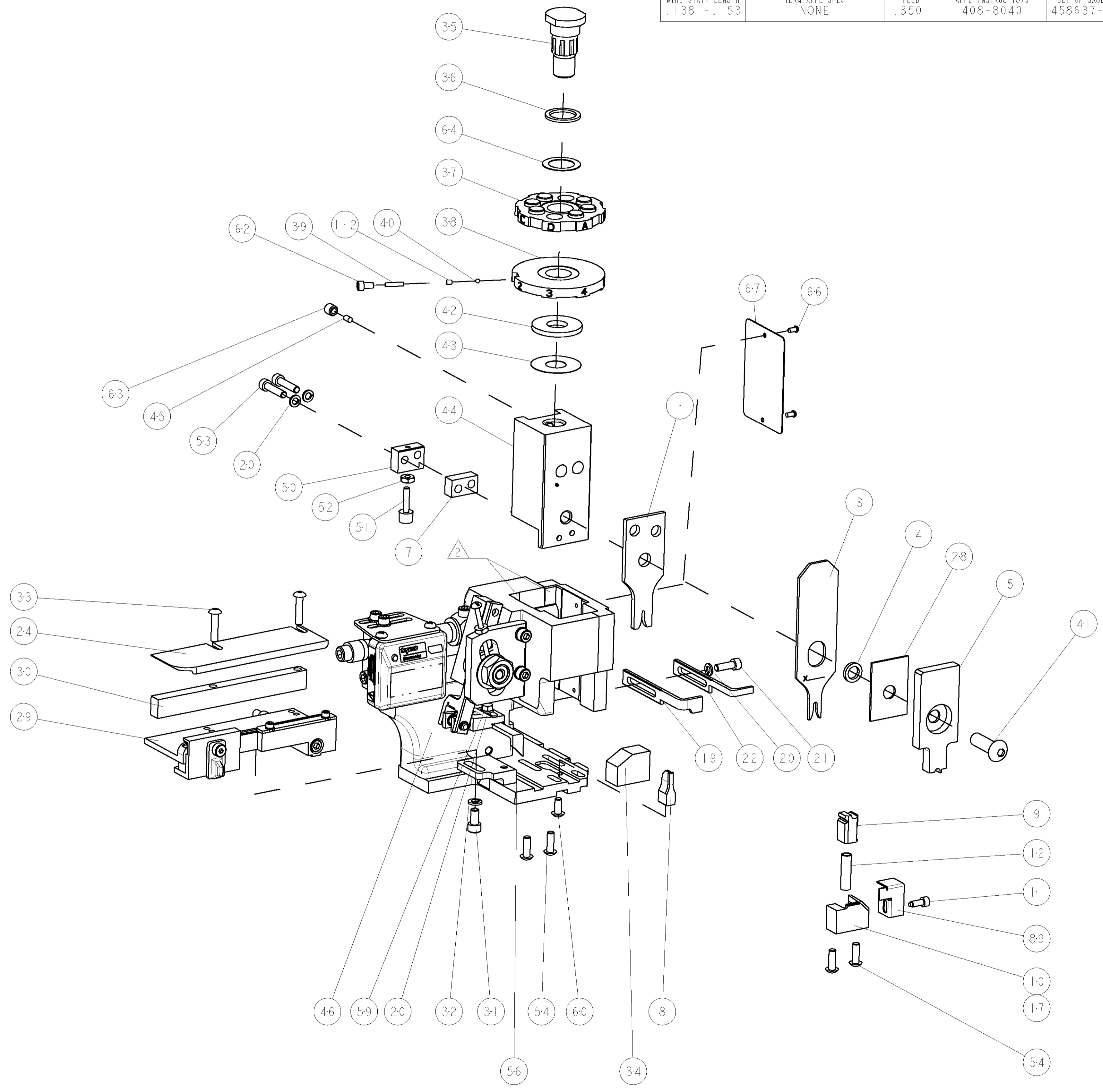
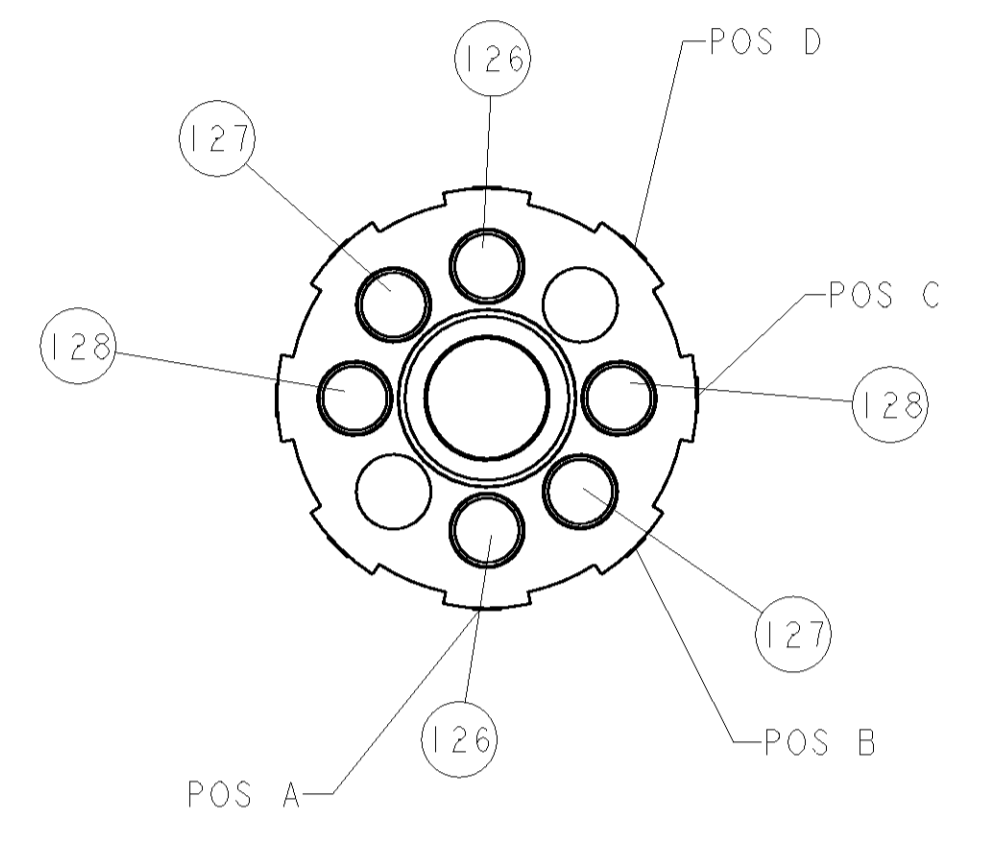

FEED TRACK POSITION

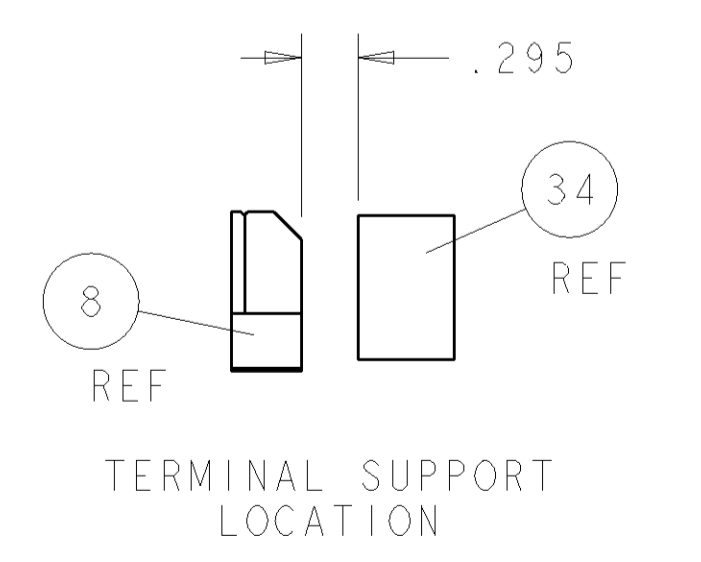

TERMINAL SUPPORT LOCATION

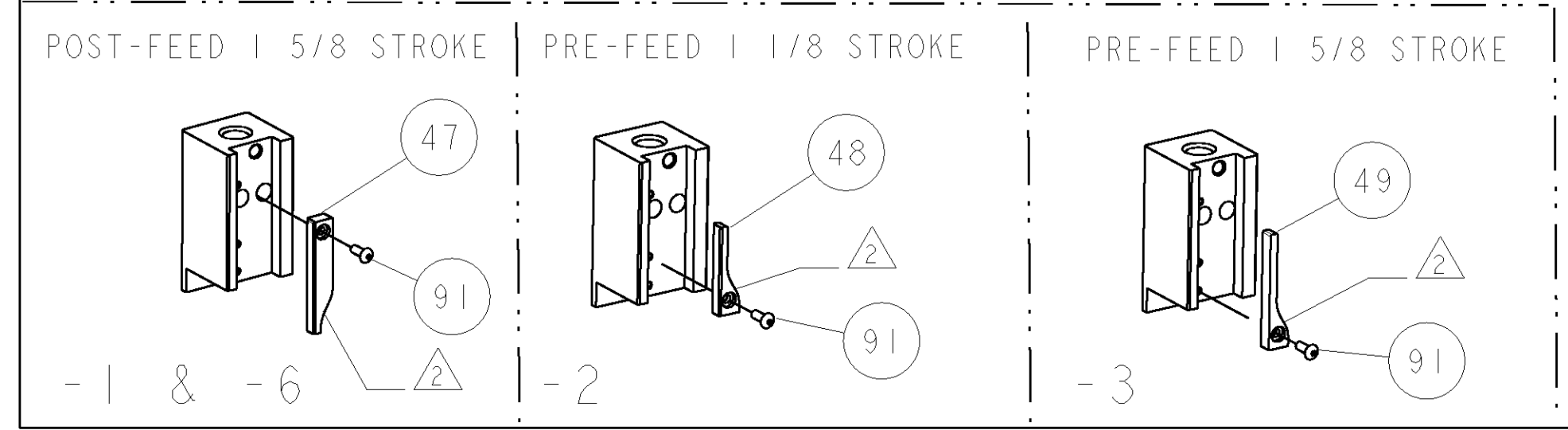

-	2	2	2	2	-	5-354779-6	PIN, WIRE DISC, .3270	128
-	2	2	2	2	-	4-354779-8	PIN, WIRE DISC, .3230	127
-	2	2	2	2	-	3-354779-9	PIN, WIRE DISC, .3185	126
-	-	-	REF	-	-	455749-1	GUARD WINDOW	116
-	-	REF	-	-	-	679532-1	INSERT, GUARD	115
-	1	1	1	1	-	690603-1	SPRING ASSIST AMP-O-MATOR APPLICATOR	112
-	1	1	1	1	-	1-21002-7	SCR, BTN SKT HD CAP 6-32 X .375	91
-	1	1	1	1	-	318563-1	GUARD, FRONT CHIP	89
-	1	1	1	1	-	4088040	SF APPL INST 408-8040	72
-	1	1	1	1	-	217238-1	GENERAL INSTRUCTION PKG	71
-	1	1	1	1	-	461264-1	PLATE, IDENTIFICATION	67
-	2	2	2	2	-	21017-2	SCREW, DRIVE	66
-	1	1	1	1	-	986950-1	WASHER, FLAT PRECISION	64
-	1	1	1	1	-	21009-2	SCR, SET, SELF LOCKING 1/4-20 X .250	63
-	1	1	1	1	-	23030-1	SCR, SKT HD CAP 6-32 X .25	62
-	1	1	1	1	-	22733-8	SCR, BHSC, SELF-LOCKING, 8-32 X .375	60
-	1	1	1	1	-	2-22603-0	SCR, HEX HD CAP 8-32 X .312	59
-	1	1	1	1	-	458537-2	PAWL, FEED	56
-	4	4	4	4	-	2-21002-2	SCR, BTN SKT HD CAP 8-32 X .500	54
-	2	2	2	2	-	2-21000-9	SCR, SKT HD CAP 8-32 X .750	53
-	1	1	1	1	-	21018-5	NUT, HEX, REG 6-32	52
-	1	1	1	1	-	811242-2	BUMPER, HOLD DOWN	51
-	1	1	1	1	-	690753-1	SPACER, TONKER	50
-	-	1	-	-	-	690602-6	CAM, PRE FEED, 1 5/8	49
-	1	-	-	1	-	690501-4	CAM, POST FEED, 1 5/8	47
-	1	1	1	1	-	459456-1	APPL. BASIC SUB ASSY (SIDE WISE MOCA)	46
-	1	1	1	1	-	690191-1	PLUG, NYLON	45
-	1	1	1	1	-	455673-1	RAM, SIDE FEED	44
-	1	1	1	1	-	690125-1	SHIM SUB-ASSY	43
-	1	1	1	1	-	690124-1	WASHER, RAM (.115)	42
-	1	1	1	1	-	7-21002-9	SCR, BTN SKT HD CAP 5/16-24 X 1.00	41
-	1	1	1	1	-	23241-6	BALL, STEEL	40
-	1	1	1	1	-	690170-1	SPRING, COMPRESSION	39
-	1	1	1	1	-	690142-1	DISC, INSULATION	38
-	1	1	1	1	-	354777-1	WIRE DISC, ASSEMBLY	37
-	1	1	1	1	-	22480-5	SPRING, COMPRESSION	36
-	1	1	1	1	-	690212-1	POST, RAM	35
-	1	1	1	1	-	690786-6	TERMINAL SUPPORT	34
-	2	2	2	2	-	2-21002-4	SCR, BTN SKT HD CAP 8-32 X .750	33
-	1	1	1	1	-	21024-5	WASHER, SPRG LOCK, REG NO 10	32
-	1	1	1	1	-	3-21000-4	SCR, SKT HD CAP 10-32 X .375	31
-	1	1	1	1	-	1-1320908-5	SPACER, STRIP GUIDE	30
-	1	1	1	1	-	1633091-1	ASSEMBLY, STRIP GUIDE	29
-	1	1	1	1	-	1-455888-0	SPACER, CRIMPER	28
-	1	1	1	1	-	1320928-1	PLATE, STRIP GUIDE	24
-	1	-	-	1	-	690472-2	STRIPPER	22
-	1	1	1	1	-	2-21000-7	SCR, SKT HD CAP 8-32 X .500	21
-	4	4	4	4	-	21024-4	WASHER, SPRG LOCK, REG NO 8	20
-	-	1	1	-	-	691353-1	STRIPPER	19
-	1	-	-	-	-	679625-1	SHEAR HOLDER, FRONT (NO CUT)	17
-	1	1	1	1	-	3-22280-3	SPRING, COMPRESSION	12
-	1	1	1	1	-	690461-1	STOP, SHEAR	11
-	-	1	1	1	-	690459-1	SHEAR HOLDER, FRONT	10
-	1	1	1	1	-	462006-7	FLOATING SHEAR, FRONT	9
1	1	1	1	1	-	2-1633107-2	ANVIL, COMBINATION .062	8
-	1	1	1	1	-	6-240641-8	SPACER	7
-	1	1	1	1	-	2-455889-0	DEPRESSOR, SHEAR	5
-	1	1	1	1	-	238011-7	BLOCK, CRIMPER SPACER	4
1	1	1	1	1	-	3-683454-1	CRIMPER, INSULATION O	3
1	1	1	1	1	-	4-459492-4	CRIMPER, WIRE O	1

DIMENSIONS:	TOLERANCES UNLESS OTHERWISE SPECIFIED:	APPROVED:	DATE:	BY:	FOR:
INCHES	0 PLC ±.010 1 PLC ±.005 2 PLC ±.003 3 PLC ±.002 4 PLC ±.001 ANGLES ±.0001	APPROVED: [Signature]	DATE: 23MAY2006	BY: [Signature]	FOR: [Signature]
MATERIAL:	FINISH:	WEIGHT:	SCALE: 3:5	SHEET: 1 OF 1	REV: A

CUSTOMER VIEWABLE ASSEMBLY

# Mouser Electronics

Authorized Distributor

Click to View Pricing, Inventory, Delivery & Lifecycle Information:

[TE Connectivity:](#)

[1852277-2](#)