

REVISIONS				
P	LTR	DESCRIPTION	DATE	DWN
C		REVISED PER ECO-16-001480	02MAY2016	RS

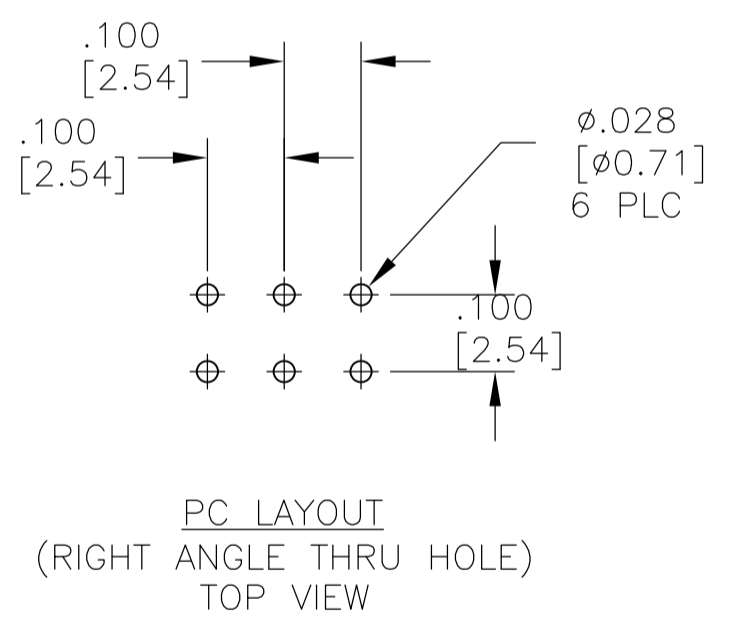
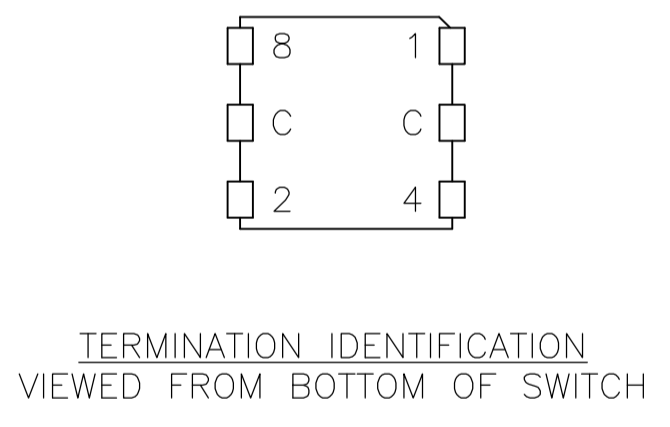
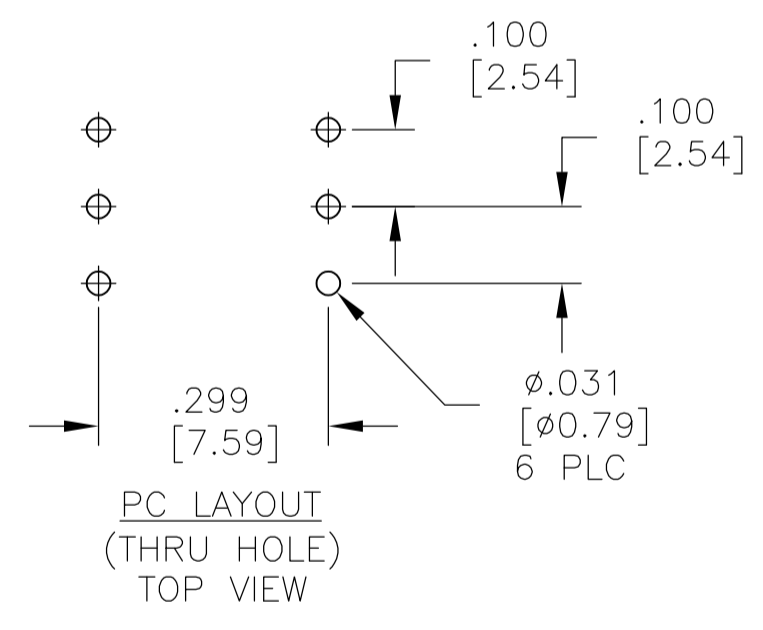
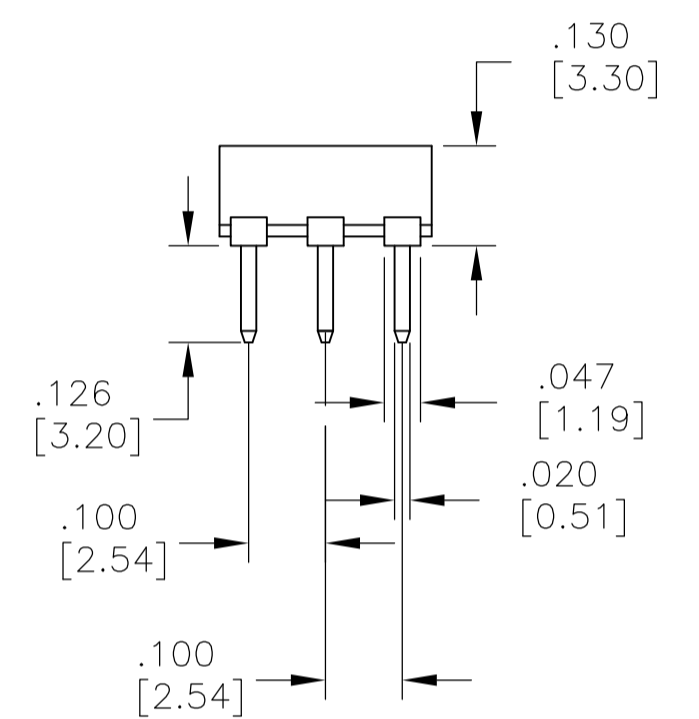
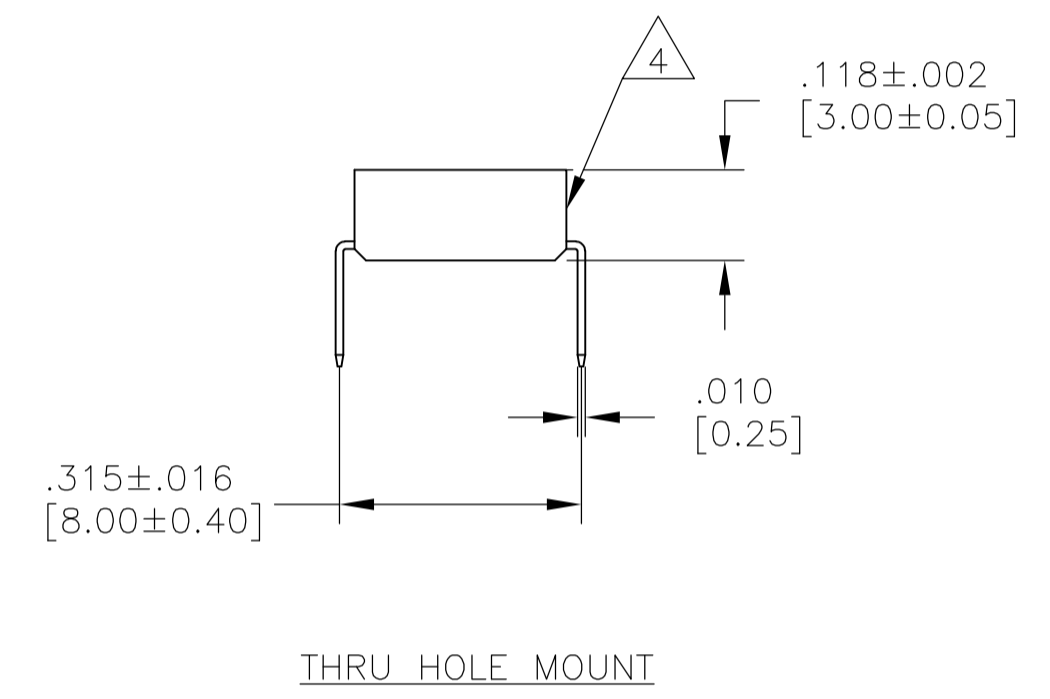
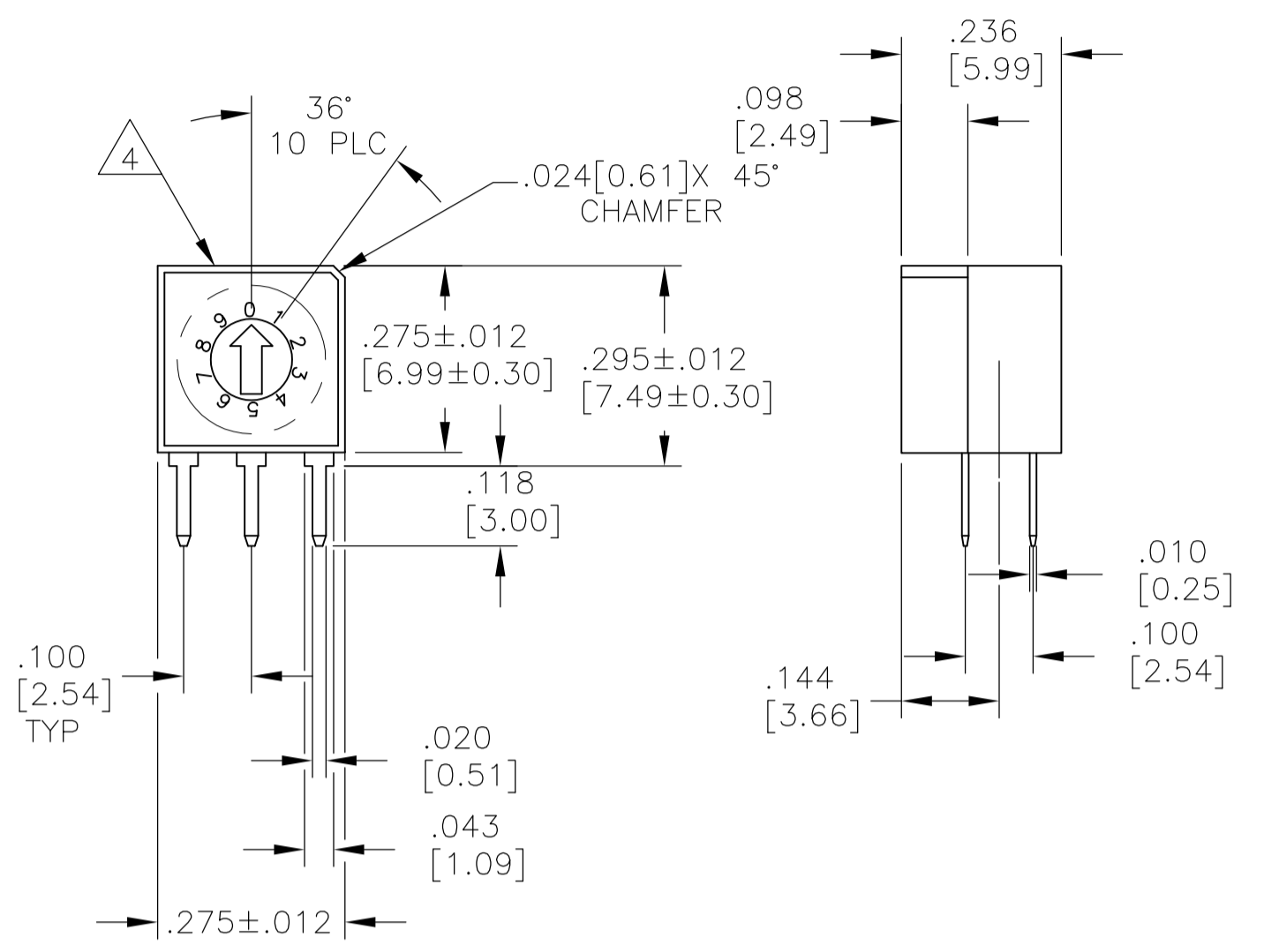
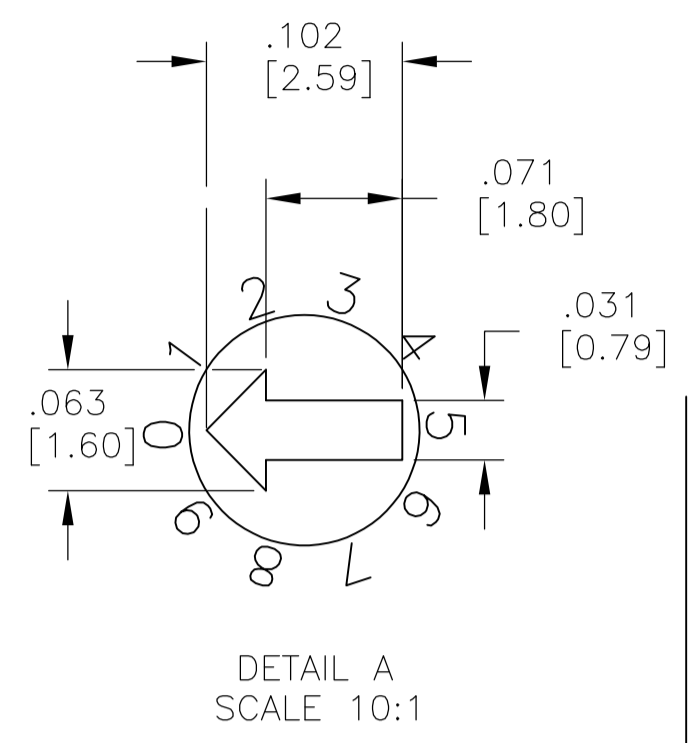
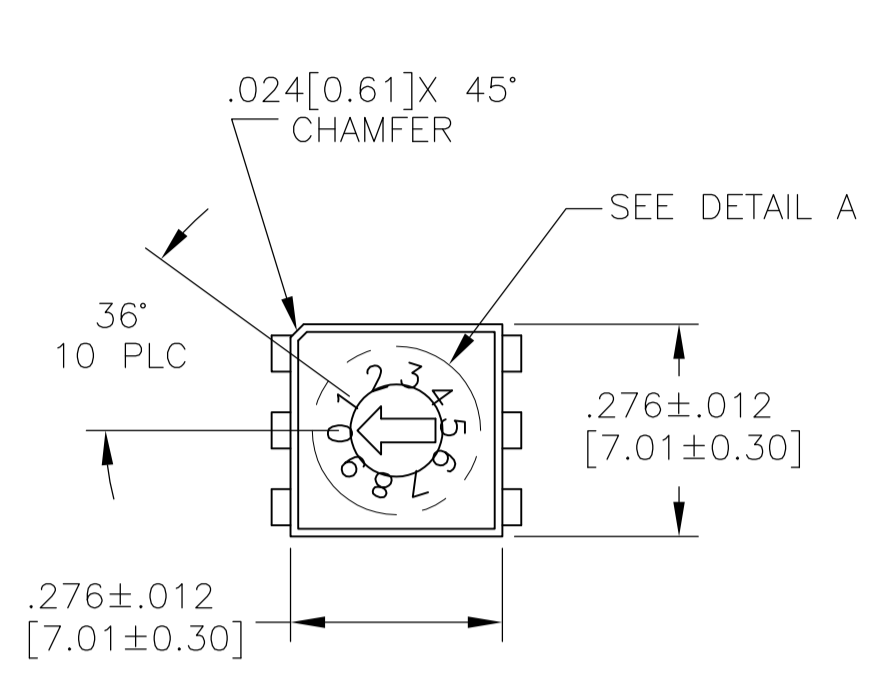

SPECIFICATIONS:

MATERIAL
CASE & COVER, PPS, UL94V-0, BLACK
ACTUATOR/ROTOR, PA6T, UL94V-0, SEE P/N TABLE FOR COLOR
FIXED CONTACT/TERMINAL: COPPER ALLOY-GOLD OVER NICKEL PLATE
MOVING CONTACT, COPPER ALLOY- GOLD OVER NICKEL PLATE
PLATE, STAINLESS STEEL
SPRING, STAINLESS STEEL
O-RING, RUBBER

ELECTRICAL
MAX CONTACT RATING SWITCHING, .4VA @ 20 V AC OR DC
MIN CONTACT RATING SWITCHING, 1MICROAMP @ 1 MILLIVOLT
INITIAL CONTACT RESISTANCE, 100 MILLIOHMS MAX. @ 2V DC 10MILLIAMPS
CONTACT RESISTANCE AFTER TEST, 300 MILLIOHMS MAX.
INSULATION RESISTANCE, 1,000 MEGOHMS MIN. @ 250 VDC
DIELECTRIC STRENGTH, 250 VAC RMS @ SEA LEVEL
LIFE, 10,000 STEPS MIN. @ 5V DC 10MILLIAMPS

MECHANICAL
OPERATING FORCE, 200 GF-CM MAX.
MECHANICAL LIFE, 20,000 STEPS MIN., NO LOAD

ENVIRONMENTAL
OPERATING TEMPERATURE, -30 TO +85 DEGREES C
STORAGE TEMPERATURE, -45 TO + 100 DEGREES C
VIBRATION, PER EIA-364-28D, CONDITION 1
MECHANICAL SHOCK, PER EIA-364-27B, CONDITION A
RESISTANCE TO SOLDER HEAT PER 109-202 CONDITION B (THRU-HOLE), & 109-201, CONDITION B (SURFACE MOUNT)
SOLDERABILITY PER JIS-C-0050 & JIS-C-0053

NOTES:

- ALL MATERIALS AND FINISHES SHALL COMPLY WITH EU DIRECTIVE 2002/95/EC OF 27JAN2003 (ROHS)
- TO BE SUPPLIED WITH ACTUATOR AT POSITION "7" FOR MRD10C & MRD10CS, POSITION "F" FOR MRD16C & MRD16CS AND POSITION "0" FOR ALL REMAINING MODELS
- TAPE & REEL PKG PER EIA 481 TAPE WIDTH 16mm, PITCH 16mm.
- LOCATE "ALCO" TRADE NAME AND LOT NUMBER ON THIS SURFACE. LOT NUMBER TO BE MARKED AS FOLLOWS.
1ST DIGIT YEAR
2ND DIGIT MONTH
- OBsolete PART.

GREEN	MRD16RASTR04	2-1825013-4
WHITE	MRD16CRASTR04	2-1825013-3
RED	MRD10RASTR04	2-1825013-2
ORANGE	MRD10CRASTR04	2-1825013-1
GREEN	MRD16STR04	2-1825013-0
GREEN	MRD16S04	1-1825013-9
GREEN	MRD16RAS04	1-1825013-8
GREEN	MRD16RA04	1-1825013-7
WHITE	MRD16CSTR04	1-1825013-6
WHITE	MRD16CRAS04	1-1825013-5
WHITE	MRD16CRA04	1-1825013-4
WHITE	MRD16C04	1-1825013-2
GREEN	MRD1604	1-1825013-1
RED	MRD10STR04	1-1825013-0
RED	MRD10S04	1825013-9
RED	MRD10RAS04	1825013-8
RED	MRD10RA04	1825013-7
ORANGE	MRD10CSTR04	1825013-6
ORANGE	MRD10CS04	1825013-5
ORANGE	MRD10CRA04	1825013-4
ORANGE	MRD10CRA04	1825013-3
ORANGE	MRD10C04	1825013-2
RED	MRD1004	1825013-1
ROTOR COLOR	OLD T&B P/N	P/N

HOW TO ORDER: MRD- [] [] []

CIRCUIT TYPES:
10 = BC DECIMAL
10C = BCD COMPLIMENT
16 = HEXADECIMAL
16C = HEXADECIMAL COMPLIMENT

TERMINATIONS:
BLANK = PC
S = OUTSIDE L, SURFACE MOUNT
RA= RIGHT ANGLE

PACKAGING:
TR = TAPE & REEL
(SURFACE MOUNT ONLY SEE SHEET 3)

THIS DRAWING IS A CONTROLLED DOCUMENT. DWN: M. BINNER 25JUL02
CHK: M. SARVER 25JUL02
APRD: M. SARVER 25JUL02

DIMENSIONS:	TOLERANCES UNLESS OTHERWISE SPECIFIED:	PRODUCT SPEC	APPLICATION SPEC
INCHES[mm]	0 PLC ± -		
	1 PLC ± -		
	2 PLC ± -		
	3 PLC ± .010(0.25)		
	4 PLC ± -		
	ANGLES ± °		

MATERIAL: SEE SPECIFICATION FINISH: - WEIGHT: -

SIZE: A1 CAGE CODE: 00779 DRAWING NO: 1825013 RESTRICTED TO: -

CUSTOMER DRAWING SCALE: 4:1 SHEET: 1 OF 2 REV: C

REVISIONS				
P	LTR	DESCRIPTION	DATE	APP'D
-	-	SEE SHEET 1	-	-

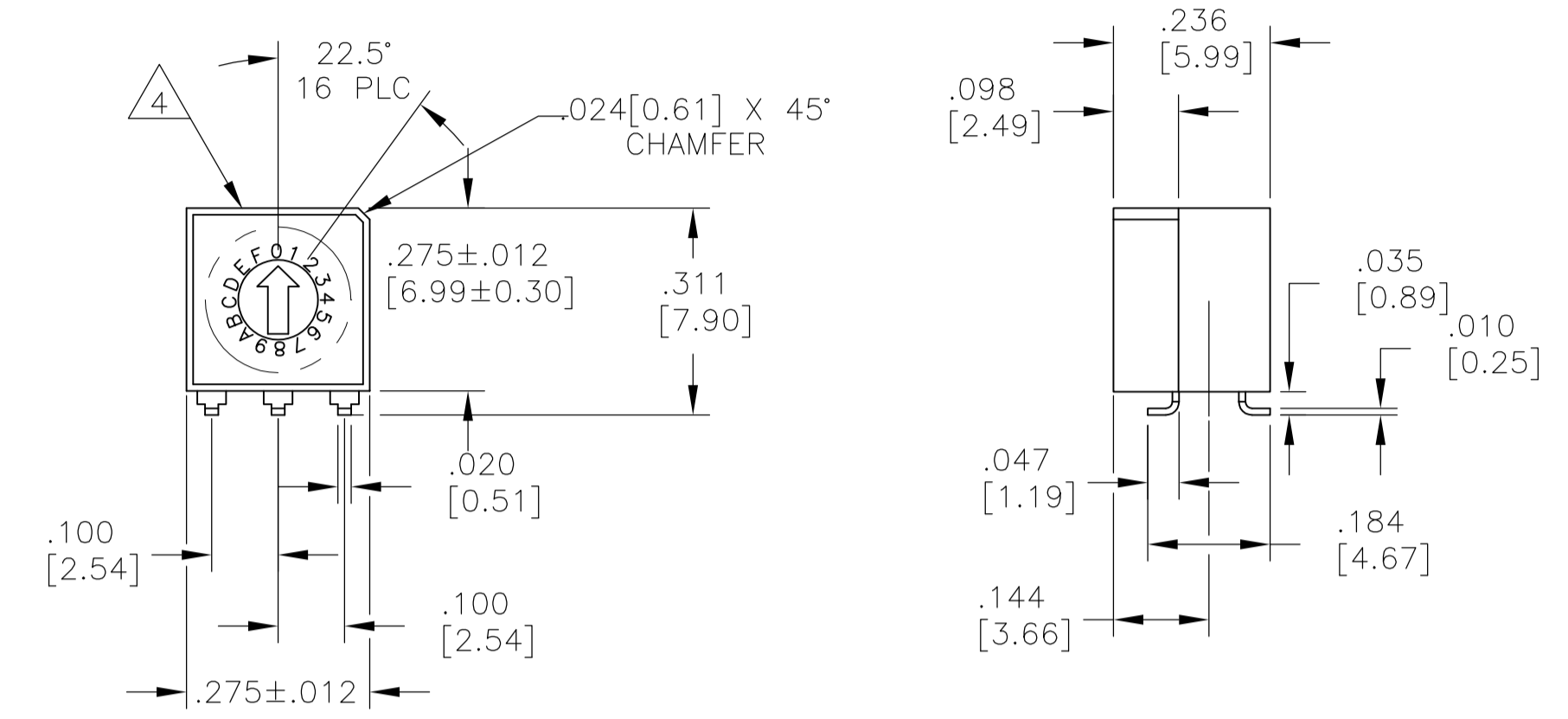
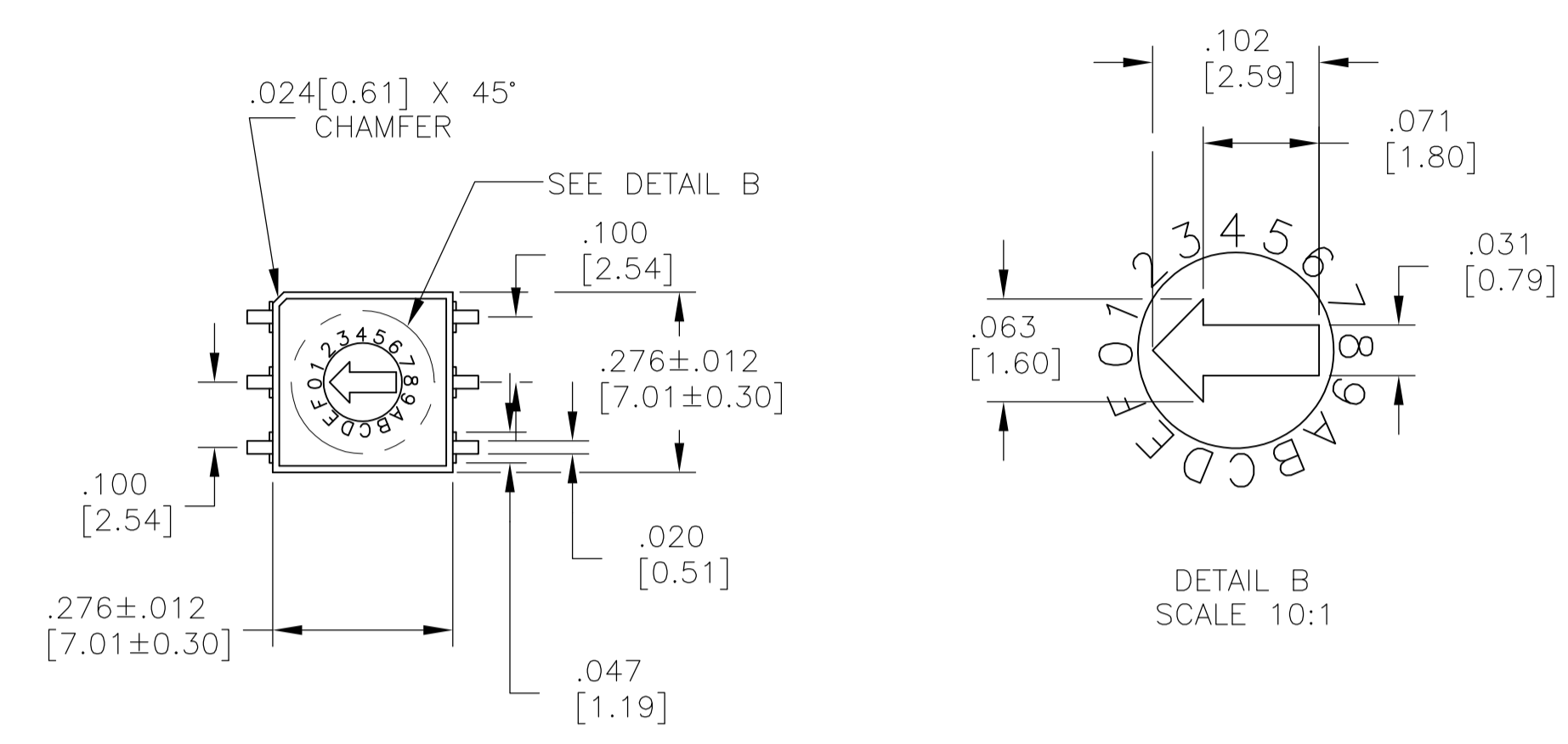

10 POSITION, BCD COMPLEMENT										
POS	0	1	2	3	4	5	6	7	8	9
C	X	X	X	X	X	X	X	X	X	X
1	X		X		X		X		X	
2	X	X			X	X			X	X
4	X	X	X	X					X	X
8	X	X	X	X	X	X	X	X		

10 POSITION, BCD										
POS	0	1	2	3	4	5	6	7	8	9
C	X	X	X	X	X	X	X	X	X	X
1		X		X		X		X		X
2			X	X			X	X		
4					X	X	X	X		
8									X	X

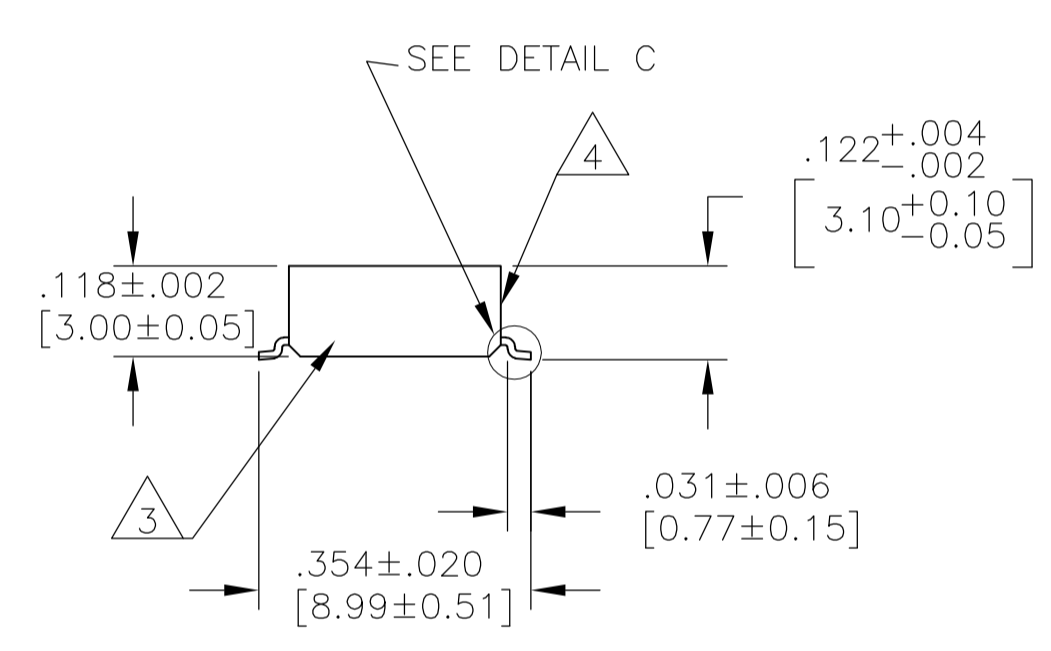
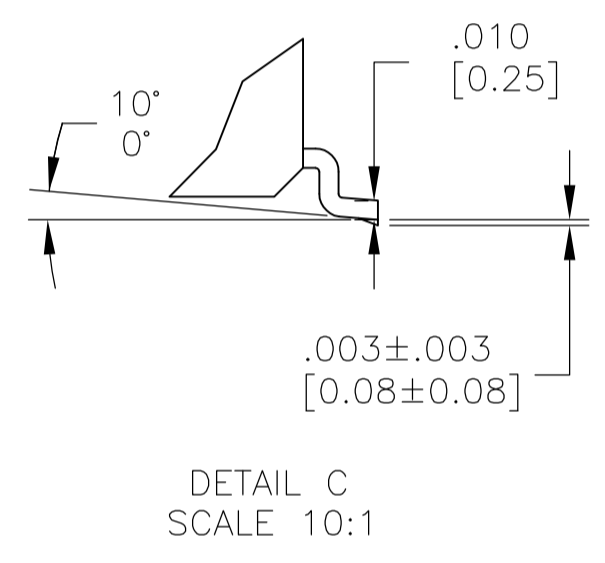

16 POSITION, HEXADECIMAL																
POS	0	1	2	3	4	5	6	7	8	9	A	B	C	D	E	F
C	X	X	X	X	X	X	X	X	X	X	X	X	X	X	X	X
1		X		X		X		X		X		X		X		X
2			X	X			X	X			X	X			X	X
4					X	X	X	X					X	X	X	X
8									X	X	X	X	X	X	X	X

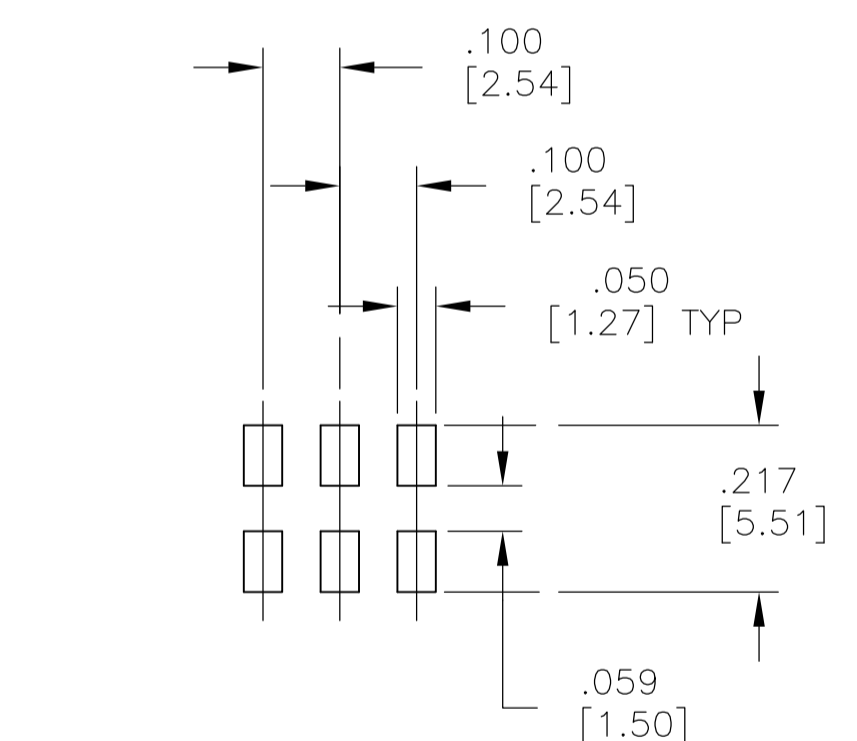

16 POSITION, HEXADECIMAL COMPLEMENT																
POS	0	1	2	3	4	5	6	7	8	9	A	B	C	D	E	F
C	X	X	X	X	X	X	X	X	X	X	X	X	X	X	X	X
1	X		X		X		X		X		X		X		X	
2	X	X			X	X			X	X			X	X		
4	X	X	X	X					X	X	X	X				
8	X	X	X	X	X	X	X	X								

COLOR CODE		
CIRCUIT TYPE	ACTUATOR	COLOR
10		RED
10C		ORANGE
16		GREEN
16C		WHITE

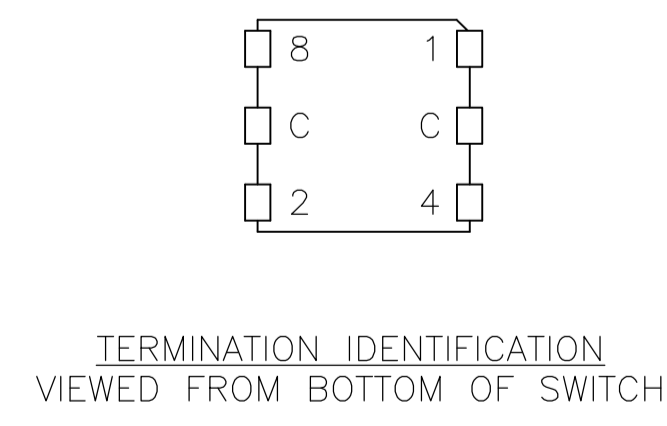
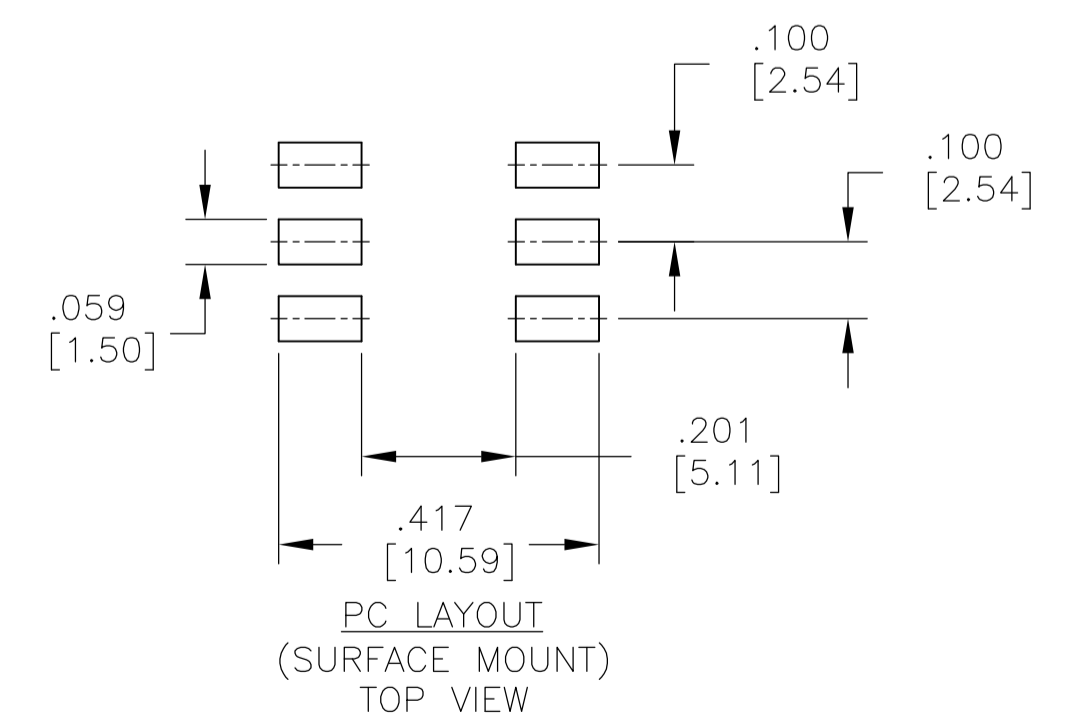

THIS DRAWING IS A CONTROLLED DOCUMENT.

DIMENSIONS: INCHES[mm]	TOLERANCES UNLESS OTHERWISE SPECIFIED:	DWN: M. BINNER 25JUL02	CHK: M. SARVER 25JUL02	AP'D: M. SARVER 25JUL02	NAME: M. SARVER
0. PLC ± .010	1. PLC ± .010	PRODUCT SPEC: -	APPLICATION SPEC: -	SIZE: A1	CAGE CODE: -
2. PLC ± .010	3. PLC ± .010	WEIGHT: -	SCALE: 4:1	DRAWING NO: 00779	DRAWING NO: 1825013
4. PLC ± .010	ANGLES ± .5°	CUSTOMER DRAWING	SHEET 2 OF 2	REV C	RESTRICTED TO: -

STE TE Connectivity

MRD SERIES 7MM ROTARY DIP SWITCH