

THIS DRAWING IS UNPUBLISHED. RELEASED FOR PUBLICATION SEP. 2005.
 © COPYRIGHT 2005 BY TYCO ELECTRONICS CORPORATION. ALL RIGHTS RESERVED.

LOC	DIST	REVISIONS 変更					
J	/	P	LTR	DESCRIPTION	DATE	DWN	APVD
			N	REVISED	01SEP09	Y.H	Y.N

- 1 CONTACT COPLANALITY IS 0.1 MAX.
- 2 THIS DIMENSION MEANS CENTER OF THE POCKET.
- 3 M3 TAPPING + BVTP RECOMMENDED TORQUE: 68.6N (7Kgf) MAX.
- 4 FINISH
CONTACT: V μm MIN. Au PL. ON CONTACT AREA (V: SEE TABLE)
0.03~0.1 μm Au PL. ON TERMINAL AREA
Ni UNDER PL. ALL OVER
SHELL: Sn PL. (MATTE) ALL OVER
Ni UNDER PL. ALL OVER
- 5 SCREW SIZE
- 6 QTY PRINT ON THE LABEL. (EMBOSS PACKING)

- 1 コンタクトコプラナリティーは 0.1 以下。
- 2 本寸法はポケットの中心を表す。
- 3 M3 TAPPING + BVTP 推奨トルク: 68.6N (7Kgf) 以下。
- 4 仕上
コンタクト: コンタクトエリアに V μm 以上の 金めっき (V: 表参照)
ターミナルエリアに 0.03~0.1 μm の金めっき
ニッケル下地めっきを施す
シェル: すずめっき (つや消し)
ニッケル下地めっきを施す
- 5 スクリューサイズ
- 6 数量はラベルに印字される (EMBOSS 梱包)

0.76	M3 x 0.5	70	1.9	46	138	6-23	46	-	-	-	-	-	-	-	-	WITH TAPE	WITH FLANGE	THROUGH HOLE	(SEE SHEET 3)	SOFT TRAY (SEE SHEET 7)	9-1903015-4
0.3	M3 x 0.5	200	1.9	-	-	-	-	45.5	49.5	18.3	0.5	44	40.4	20.2	20	WITH TAPE	WITH FLANGE	THROUGH HOLE	(SEE SHEET 3)	EMBOSS (SEE SHEET 6)	9-1903015-3
0.3	M3 x 0.5	70	1.9	-	-	-	-	-	-	-	-	-	-	-	-	WITHOUT TAPE	WITH FLANGE	THROUGH HOLE	(SEE SHEET 3)	SOFT TRAY (SEE SHEET 10)	8-1903015-4
0.1	-	550	1.9	-	-	-	-	33.5	37.5	9.32	0.4	32	28.4	14.2	16	WITHOUT TAPE	WITHOUT FLANGE	THROUGH HOLE	(SEE SHEET 2)	EMBOSS (SEE SHEET 6)	7-1903015-1
0.3	M3 x 0.5	200	1.9	-	-	-	-	45.5	49.5	18.3	0.5	44	40.4	20.2	20	WITHOUT TAPE	WITH FLANGE	FULL SMT	(SEE SHEET 5)	EMBOSS (SEE SHEET 6)	5-1903015-9
0.3	-	550	0.8	-	-	-	-	33.5	37.5	9.32	0.4	32	28.4	14.2	16	WITHOUT TAPE	WITHOUT FLANGE	THROUGH HOLE	(SEE SHEET 2)	EMBOSS (SEE SHEET 6)	5-1903015-5
0.3	M3 x 0.5	70	1.9	46	138	6-23	46	-	-	-	-	-	-	-	-	WITHOUT TAPE	WITH FLANGE	THROUGH HOLE	(SEE SHEET 3)	SOFT TRAY (SEE SHEET 7)	5-1903015-4
0.3	M3 x 0.5	200	1.9	-	-	-	-	45.5	49.5	18.3	0.5	44	40.4	20.2	20	WITHOUT TAPE	WITH FLANGE	THROUGH HOLE	(SEE SHEET 3)	EMBOSS (SEE SHEET 6)	5-1903015-3
0.3	φ2.65±0.3	70	1.9	46	138	6-23	46	-	-	-	-	-	-	-	-	WITHOUT TAPE	WITH FLANGE	THROUGH HOLE	(SEE SHEET 3)	SOFT TRAY (SEE SHEET 7)	5-1903015-2
0.3	-	400	1.9	-	-	-	-	33.5	37.5	9.32	0.4	32	28.4	14.2	16	WITHOUT TAPE	WITHOUT FLANGE	THROUGH HOLE	(SEE SHEET 2)	EMBOSS (SEE SHEET 6)	5-1903015-1
0.3	M3 x 0.5	70	1.0	46	138	6-23	46	-	-	-	-	-	-	-	-	WITHOUT TAPE	WITH FLANGE	THROUGH HOLE	(SEE SHEET 3)	SOFT TRAY (SEE SHEET 7)	4-1903015-1
0.76	-	400	1.2	-	-	-	-	33.5	37.5	9.32	0.4	32	28.4	14.2	16	WITHOUT TAPE	WITHOUT FLANGE	THROUGH HOLE	(SEE SHEET 2)	EMBOSS (SEE SHEET 6)	2-1903015-2
0.76	M3 x 0.5	70	1.9	-	-	-	-	-	-	-	-	-	-	-	-	WITHOUT TAPE	WITH FLANGE	THROUGH HOLE	(SEE SHEET 3)	SOFT TRAY (SEE SHEET 9)	1903015-8
0.76	φ2.65±0.3	70	1.9	-	-	-	-	-	-	-	-	-	-	-	-	WITHOUT TAPE	WITH FLANGE	THROUGH HOLE	(SEE SHEET 3)	SOFT TRAY (SEE SHEET 9)	1903015-7
0.76	M3 x 0.5	50	1.9	54.4	120	4-30	54.4	-	-	-	-	-	-	-	-	WITHOUT TAPE	WITH FLANGE	THROUGH HOLE	(SEE SHEET 3)	SOFT TRAY (SEE SHEET 9)	1903015-5
0.76	M3 x 0.5	70	1.9	46	138	6-23	46	-	-	-	-	-	-	-	-	WITHOUT TAPE	WITH FLANGE	THROUGH HOLE	(SEE SHEET 4)	SOFT TRAY (SEE SHEET 8)	1903015-4
0.76	M3 x 0.5	200	1.9	-	-	-	-	45.5	49.5	18.3	0.5	44	40.4	20.2	20	WITHOUT TAPE	WITH FLANGE	THROUGH HOLE	(SEE SHEET 4)	EMBOSS (SEE SHEET 6)	1903015-3
0.76	φ2.65±0.3	70	1.9	46	138	6-23	46	-	-	-	-	-	-	-	-	WITHOUT TAPE	WITH FLANGE	THROUGH HOLE	(SEE SHEET 3)	SOFT TRAY (SEE SHEET 7)	1903015-2
0.76	-	400	1.9	-	-	-	-	33.5	37.5	9.32	0.4	32	28.4	14.2	16	WITHOUT TAPE	WITHOUT FLANGE	THROUGH HOLE	(SEE SHEET 2)	EMBOSS (SEE SHEET 6)	1903015-1
V	U	T	AA	S	R	P	N	M	L	K	J	H	G	F	E	POLYIMIDE TAPE	FLANGE	SHELL TYPE	CONNECTOR	PACKING	PART NUMBER

4 Au PL.	5 SCREW SIZE	QTY	DIMENSION												PART LIST									
THIS DRAWING IS A CONTROLLED DOCUMENT.															DWN R.MURAYAMA 26SEP2005		Tyco Electronics Corporation Kawasaki, Japan							
DIMENSIONS: 単位: 耗 mm															CHK T.KIMURA 26SEP2005		NAME T.KIMURA							
TOLERANCES UNLESS OTHERWISE SPECIFIED: 一般公差															APVD T.KIMURA 26SEP2005		PRODUCT SPEC 製品規格 108-78180-2							
0 PLC ±															APPLICATION SPEC 取付適用規格		SIZE A3		CAGE CODE 00779		DRAWING NO G-1903015		RESTRICTED TO	
1 PLC ±															WEIGHT		SCALE 尺度 4:1		SHEET 1 OF 11		REV N			
2 PLC ±															CUSTOMER DRAWING									
3 PLC ±															FINISH 仕上									
4 PLC ±																								
ANGLES ±																								
MATERIAL 材料																								

THIS DRAWING IS UNPUBLISHED. RELEASED FOR PUBLICATION SEP, 2005.
 © COPYRIGHT 2005 BY TYCO ELECTRONICS CORPORATION. ALL RIGHTS RESERVED.

LOC	DIST	REVISIONS					
J		P	LTR	DESCRIPTION	DATE	DWN	APVD
			-	SEE SHEET 1	-	-	-

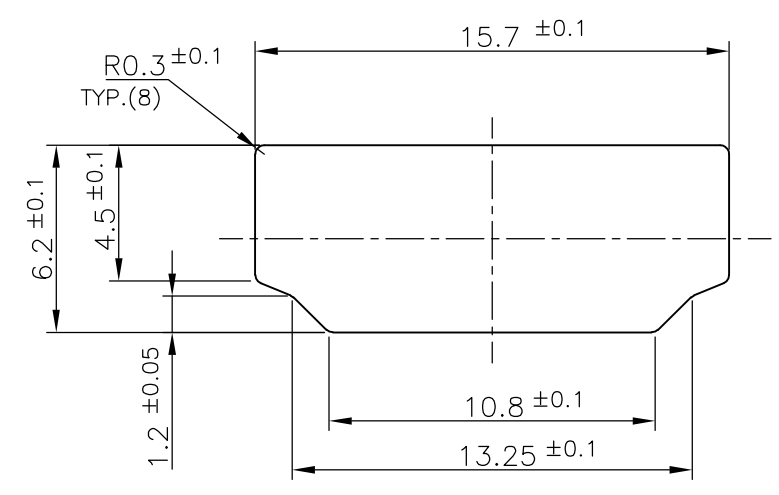
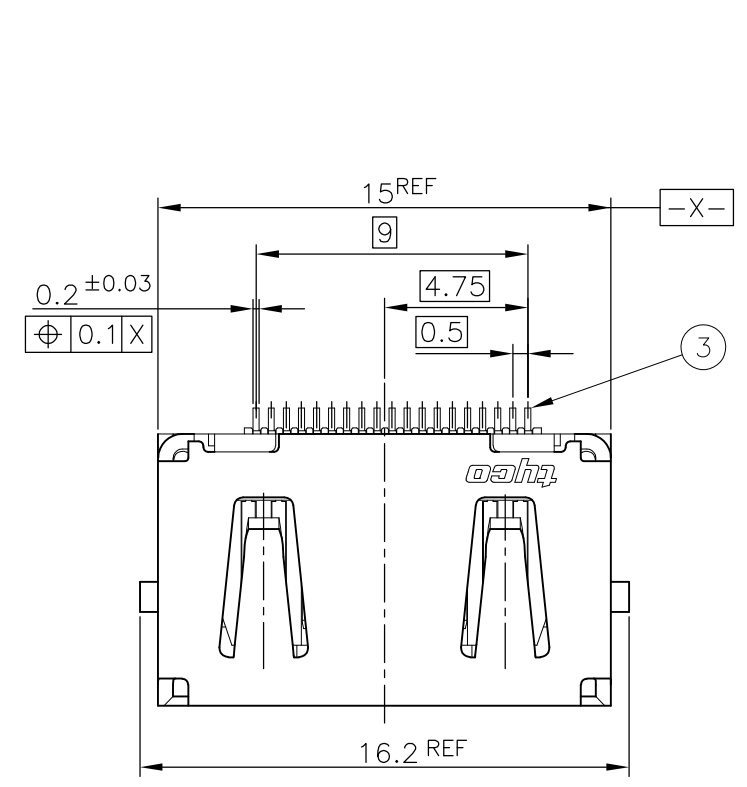

PANEL CUT OUT DIMENSION (REFERENCE)

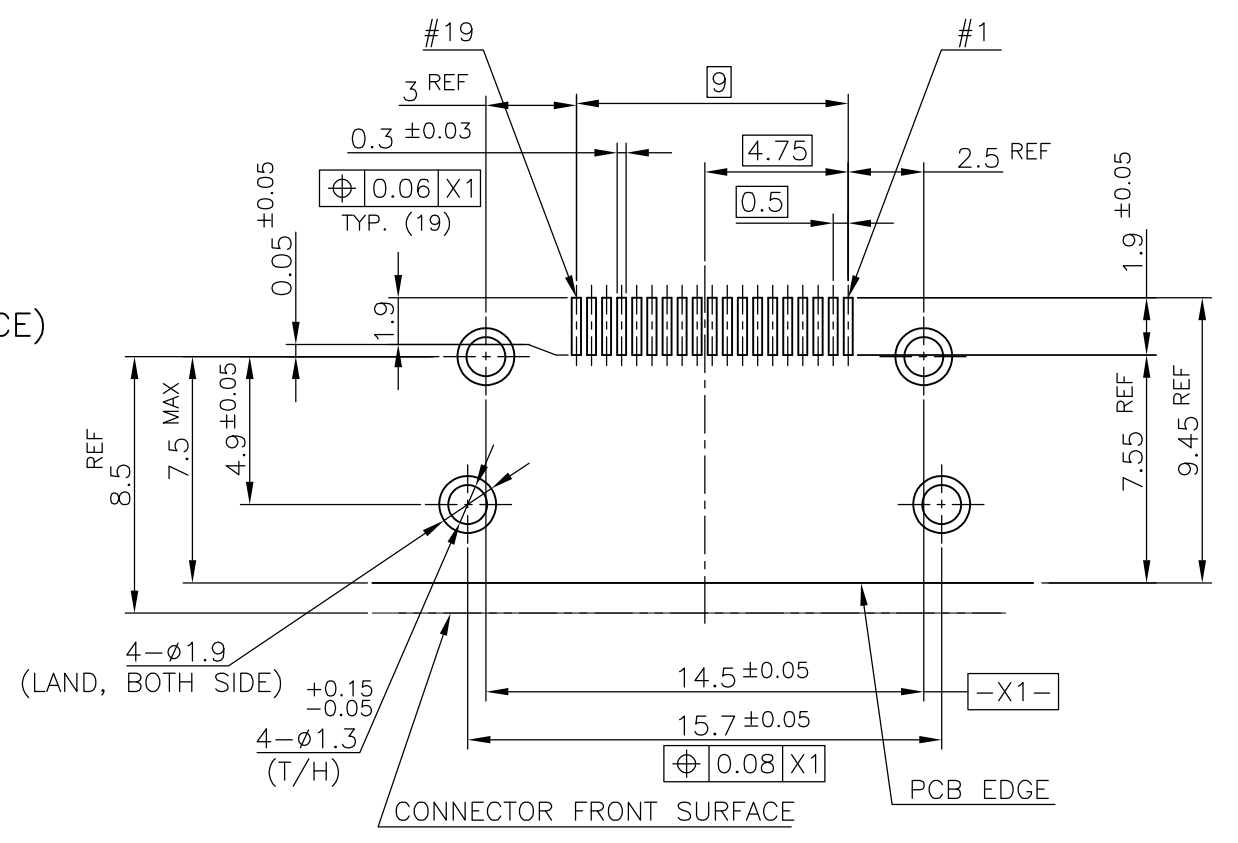

P.C.B LAYOUT (REFERENCE)
 SHOWN AS CONNECTOR MOUNTING SIDE
 TOLERANCE: NON-CUMULATIVE

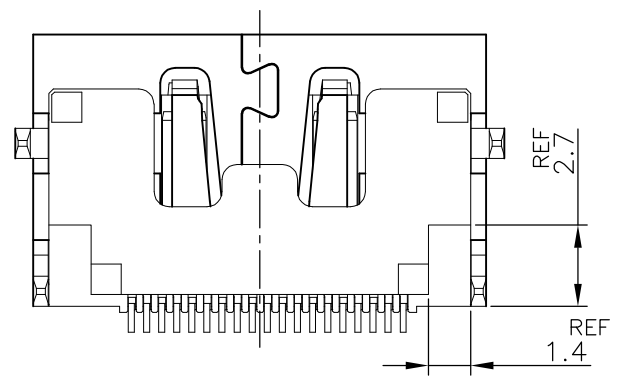
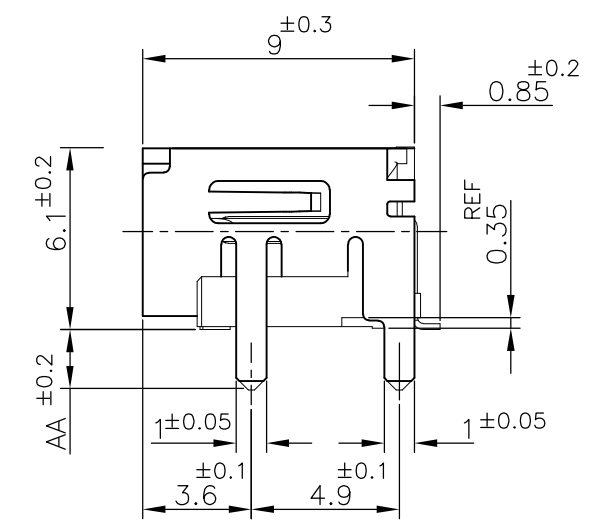
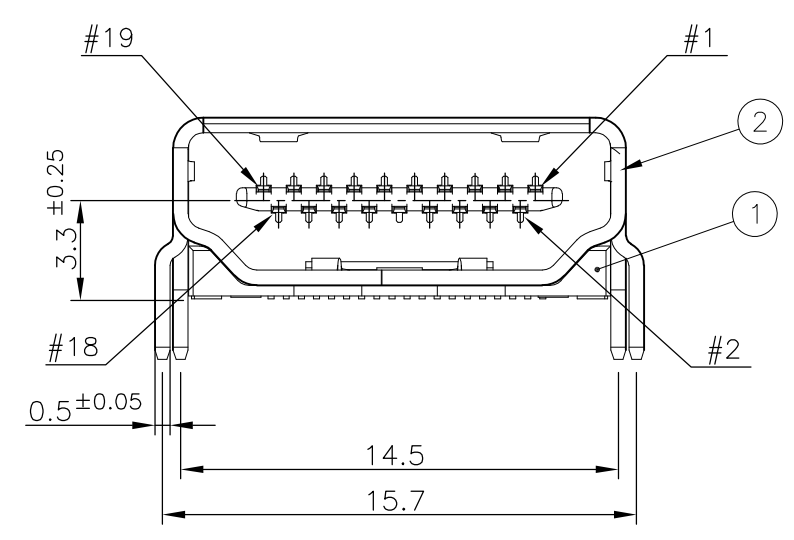

CONNECTOR: WITHOUT FLANGE THROUGH HOLE TYPE

BRASS	CONTACT	③
PHOSPHOR BRONZE	SHELL	②
GLASS FILLED LCP UL94V-0, BLACK COLOR	HOUSING	①
MATERIAL	DESCRIPTION	ITEM

THIS DRAWING IS A CONTROLLED DOCUMENT.		DWN		Tyco Electronics		Tyco Electronics Corporation	
DIMENSIONS: 単位: 耗 mm		CHK		NAME 名称		Kawasaki, Japan	
TOLERANCES UNLESS OTHERWISE SPECIFIED: 一般公差		APVD		HDMI 19 POS RECEPTACLE ASSY SMT SHORT TYPE			
0 PLC ±		PRODUCT SPEC 製品規格		SIZE		CAGE CODE	
1 PLC ±		APPLICATION SPEC 取付適用規格		DRAWING NO 番号		RESTRICTED TO	
2 PLC ±		WEIGHT		A3		00779	
3 PLC ±		CUSTOMER DRAWING		G-1903015		SCALE 4:1	
4 PLC ±						SHEET 2 OF 11	
ANGLES ±						REV N	
FINISH 仕上							

THIS DRAWING IS UNPUBLISHED. RELEASED FOR PUBLICATION SEP, 2005.
 © COPYRIGHT 2005 BY TYCO ELECTRONICS CORPORATION. ALL RIGHTS RESERVED.

LOC	DIST	REVISIONS					
J	/	P	LTR	DESCRIPTION	DATE	DWN	APVD
		-		SEE SHEET 1	-	-	-

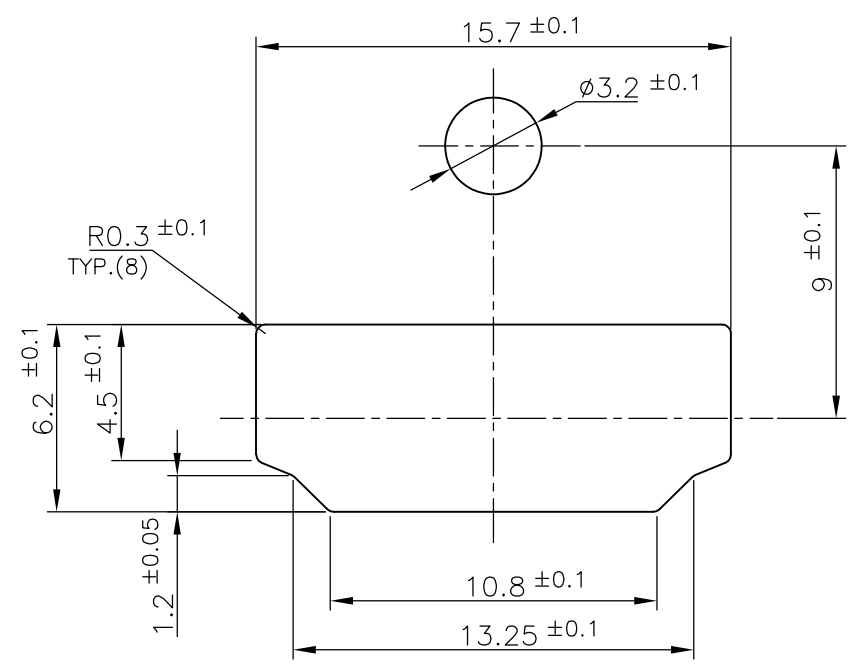
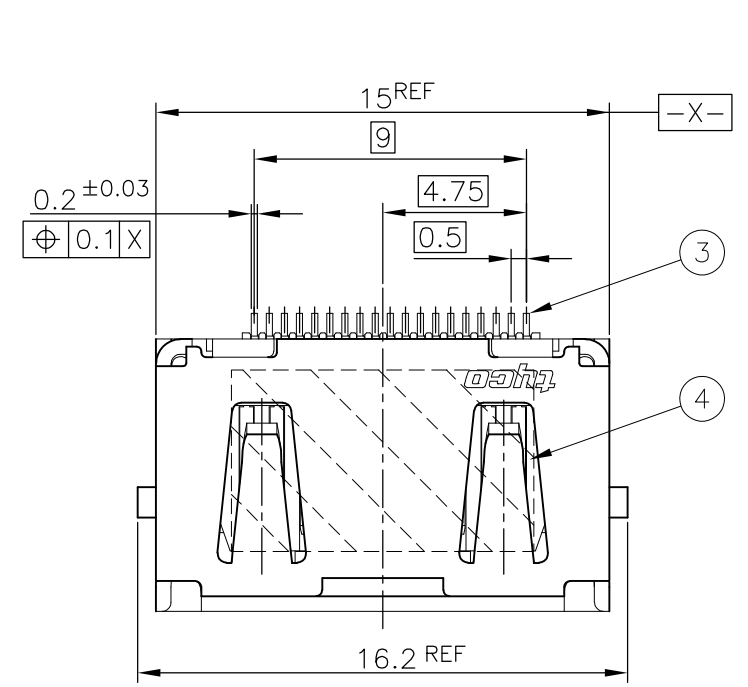

PANEL CUT OUT DIMENSION (REFERENCE)

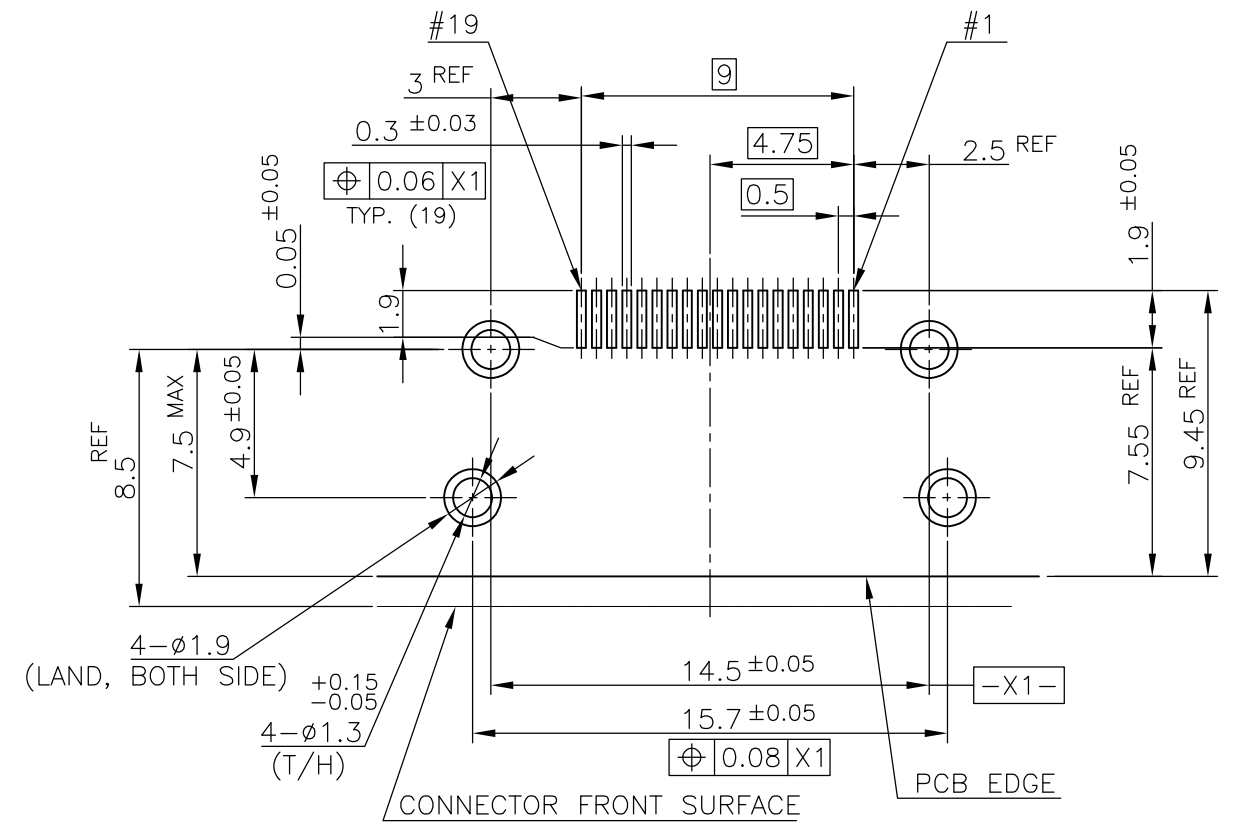
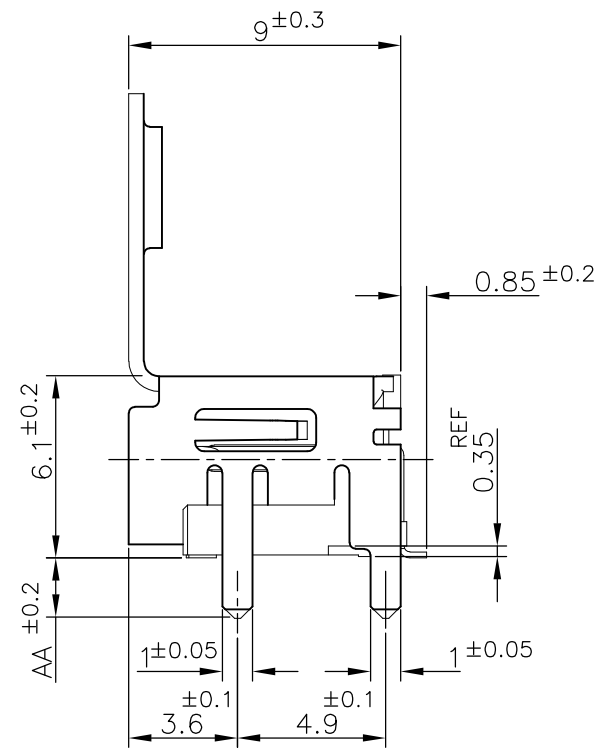
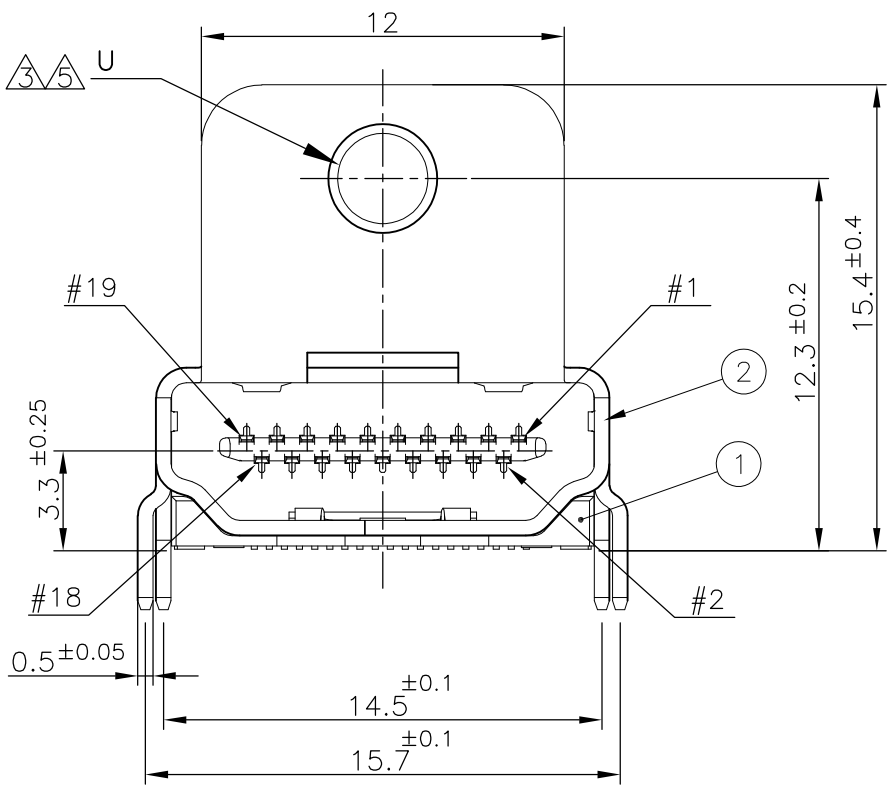

P.C.B LAYOUT (REFERENCE)
 SHOWN AS CONNECTOR MOUNTING SIDE
 TOLERANCE: NON-CUMULATIVE

POLYIMIDE	TAPE	④
BRASS	CONTACT	③
PHOSPHOR BRONZE	SHELL	②
GLASS FILLED LCP UL94V-0, BLACK COLOR	HOUSING	①
MATERIAL	DESCRIPTION	ITEM

CONNECTOR: WITH FLANGE THROUGH HOLE TYPE

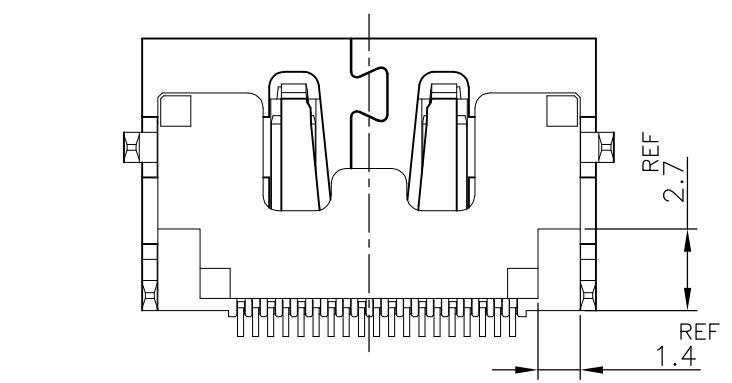

THIS DRAWING IS A CONTROLLED DOCUMENT.		DWN	Tyco Electronics Corporation Kawasaki, Japan		
DIMENSIONS: 単位: 耗 mm		CHK	NAME 名称		
TOLERANCES UNLESS OTHERWISE SPECIFIED: 一般公差		APVD	HDMI 19 POS RECEPTACLE ASSY SMT SHORT TYPE		
0 PLC ±		PRODUCT SPEC 製品規格	SIZE	CAGE CODE	DRAWING NO 番号
1 PLC ±		APPLICATION SPEC 取付適用規格	A3	00779	G-1903015
2 PLC ±		WEIGHT	RESTRICTED TO		
3 PLC ±			-		
4 PLC ±			-		
ANGLES ±			-		
FINISH 仕上		CUSTOMER DRAWING		SCALE 尺度 4:1	SHEET 3 OF 11
MATERIAL 材料				REV N	

LOC	DIST	REVISIONS					
		P	LTR	DESCRIPTION	DATE	DWN	APVD
J		-	-	SEE SHEET 1	-	-	-

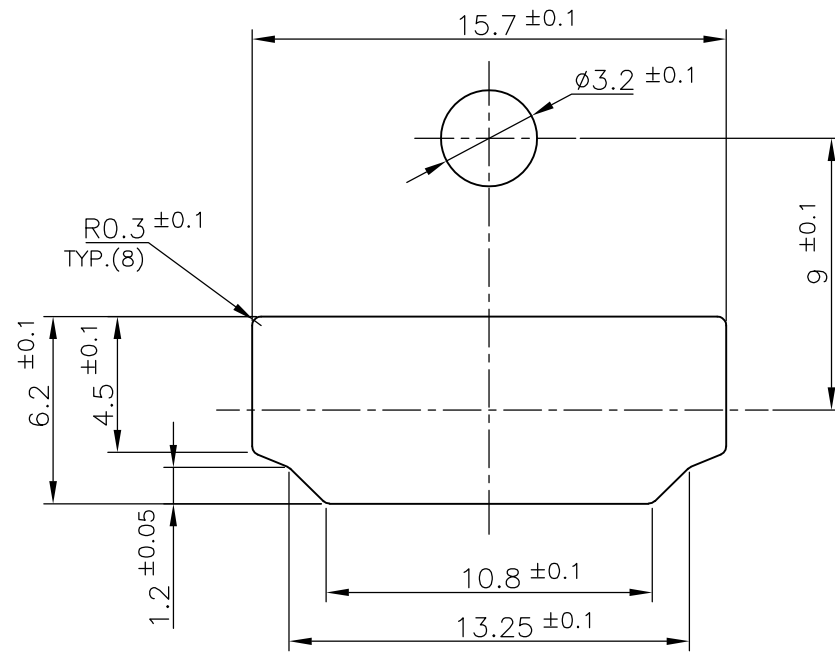
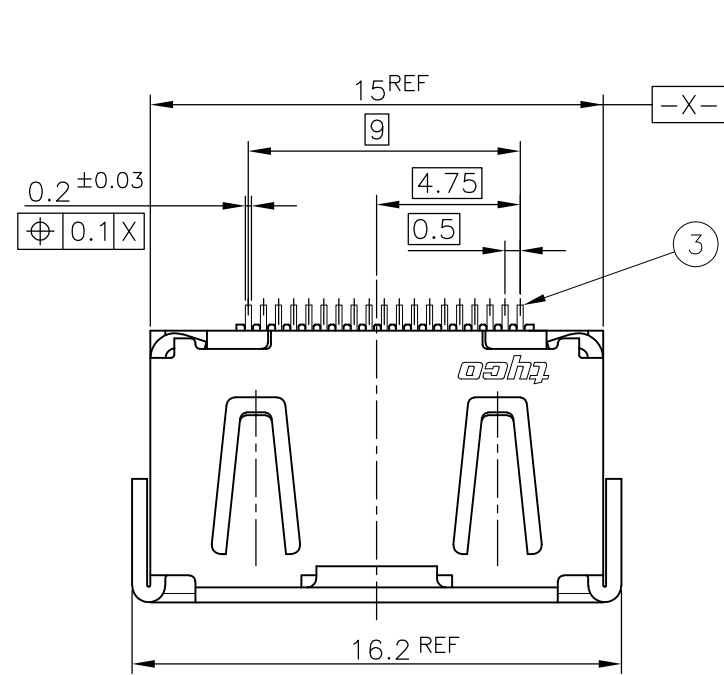

PANEL CUT OUT DIMENSION (REFERENCE)

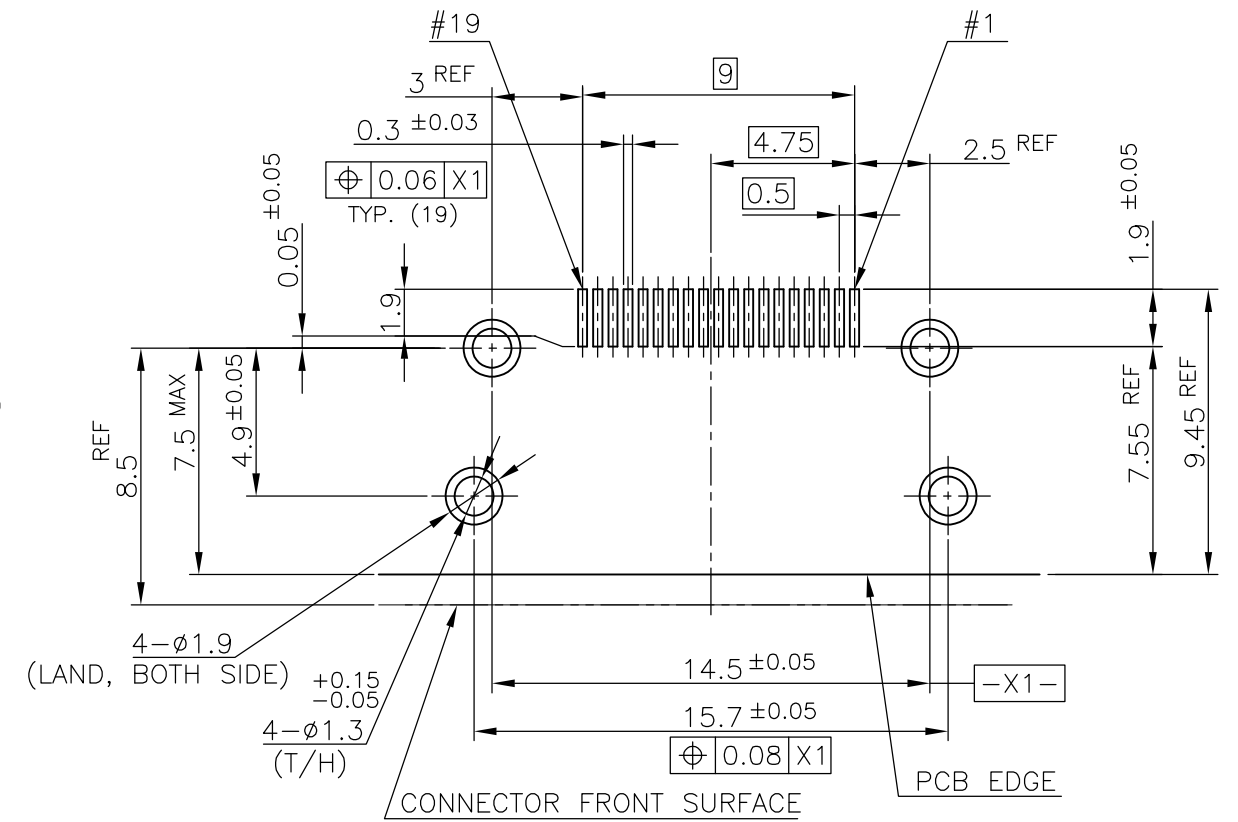

P.C.B LAYOUT (REFERENCE)
SHOWN AS CONNECTOR MOUNTING SIDE
TOLERANCE: NON-CUMULATIVE

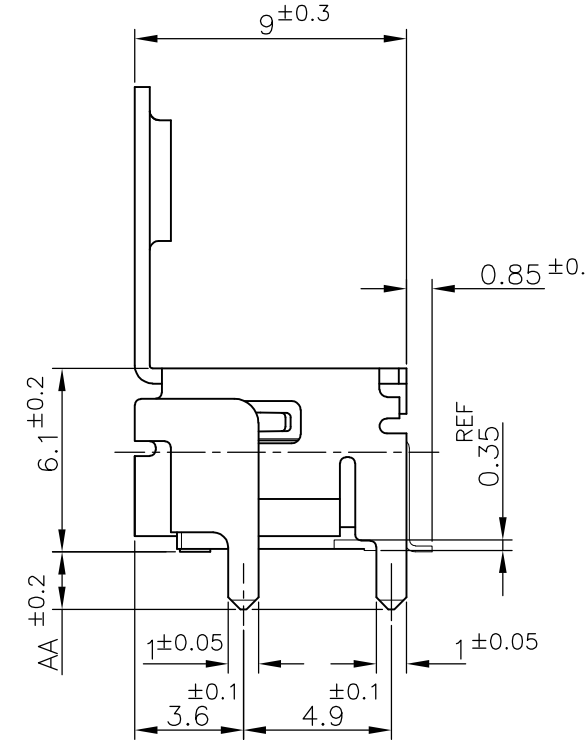
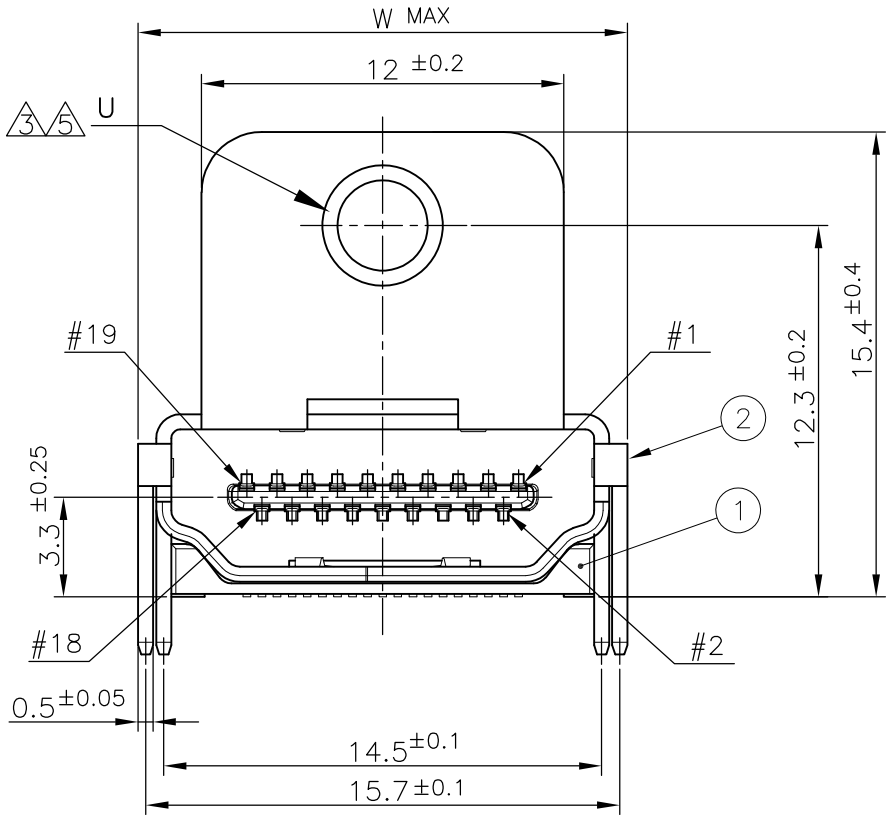

CONNECTOR: WITH FLANGE THROUGH HOLE TYPE

POLYIMIDE	TAPE	(4)
BRASS	CONTACT	(3)
PHOSPHOR BRONZE	SHELL	(2)
GLASS FILLED LCP UL94V-0, BLACK COLOR	HOUSING	(1)
MATERIAL	DESCRIPTION	ITEM

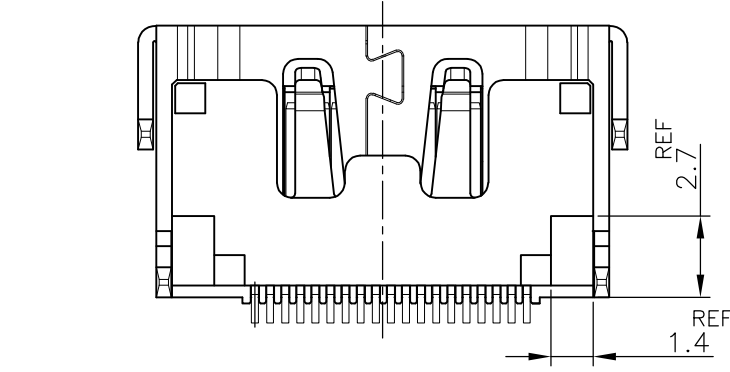

THIS DRAWING IS A CONTROLLED DOCUMENT.		DWN	Tyco Electronics Tyco Electronics Corporation Kawasaki, Japan	
DIMENSIONS: 単位: 耗 mm		CHK	NAME 名称	
TOLERANCES UNLESS OTHERWISE SPECIFIED: 一般公差		APVD	HDMI 19 POS RECEPTACLE ASSY SMT SHORT TYPE	
0 PLC ±		PRODUCT SPEC 製品規格	SIZE	RESTRICTED TO
1 PLC ±		APPLICATION SPEC 取付適用規格	CAGE CODE	-
2 PLC ±		WEIGHT	DRAWING NO 番号	
3 PLC ±		CUSTOMER DRAWING	A3	-
4 PLC ±			00779	
ANGLES ±		G-1903015		SCALE 尺度 4:1
FINISH 仕上		SCALE		SHEET 4 of 11
		REV N		

THIS DRAWING IS UNPUBLISHED. RELEASED FOR PUBLICATION SEP ,2005.
 © COPYRIGHT 2005 BY TYCO ELECTRONICS CORPORATION. ALL RIGHTS RESERVED.

LOC	DIST	REVISIONS					
J	/	P	LTR	DESCRIPTION	DATE	DWN	APVD
		-		SEE SHEET 1	-	-	-

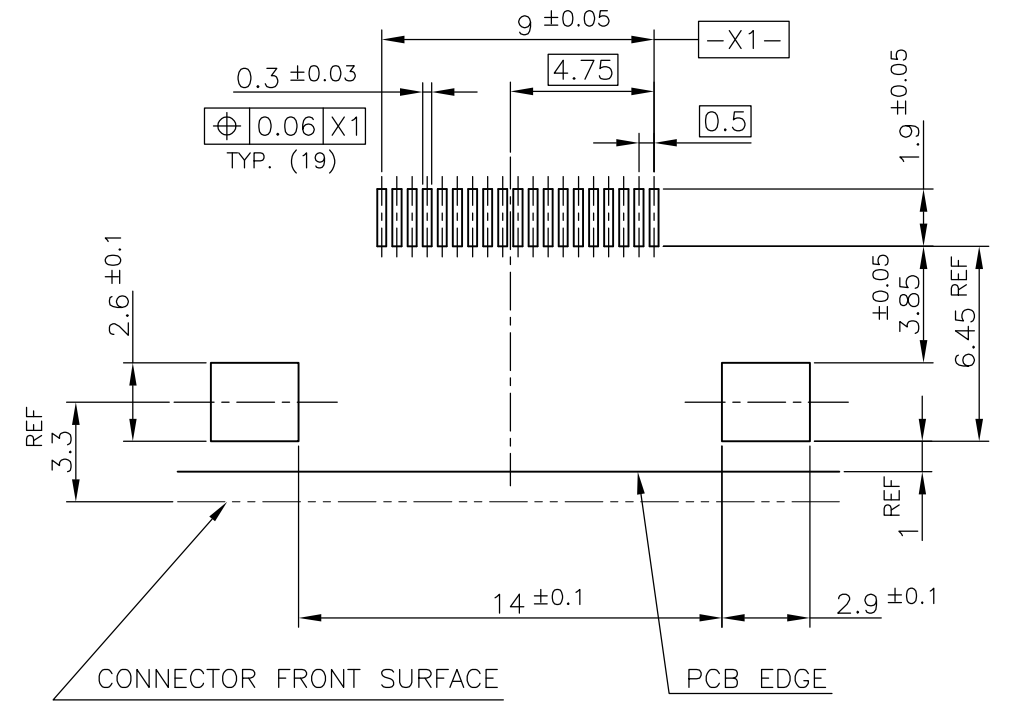
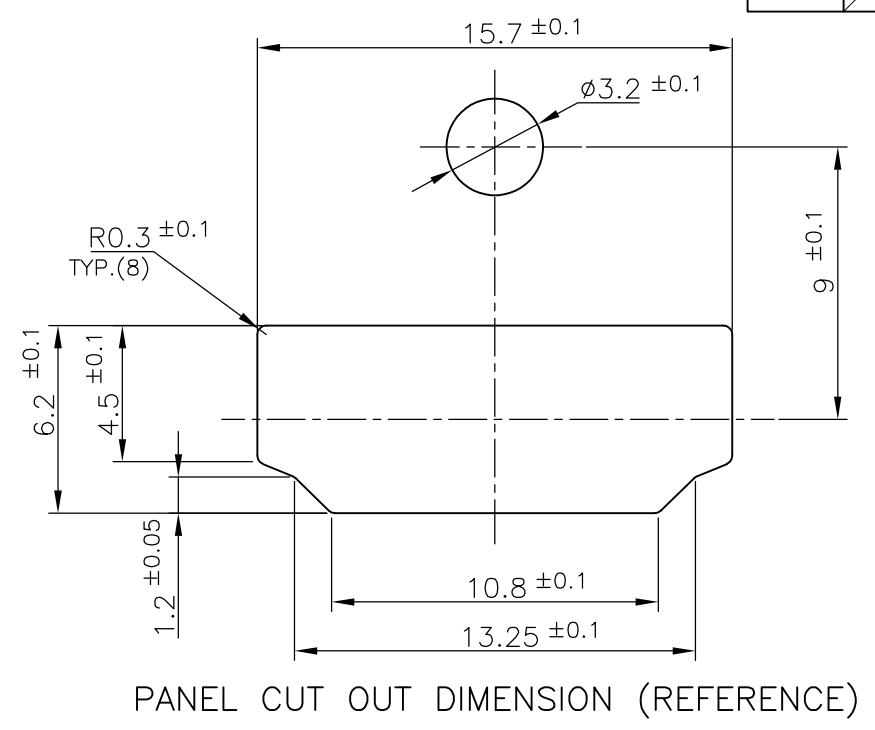
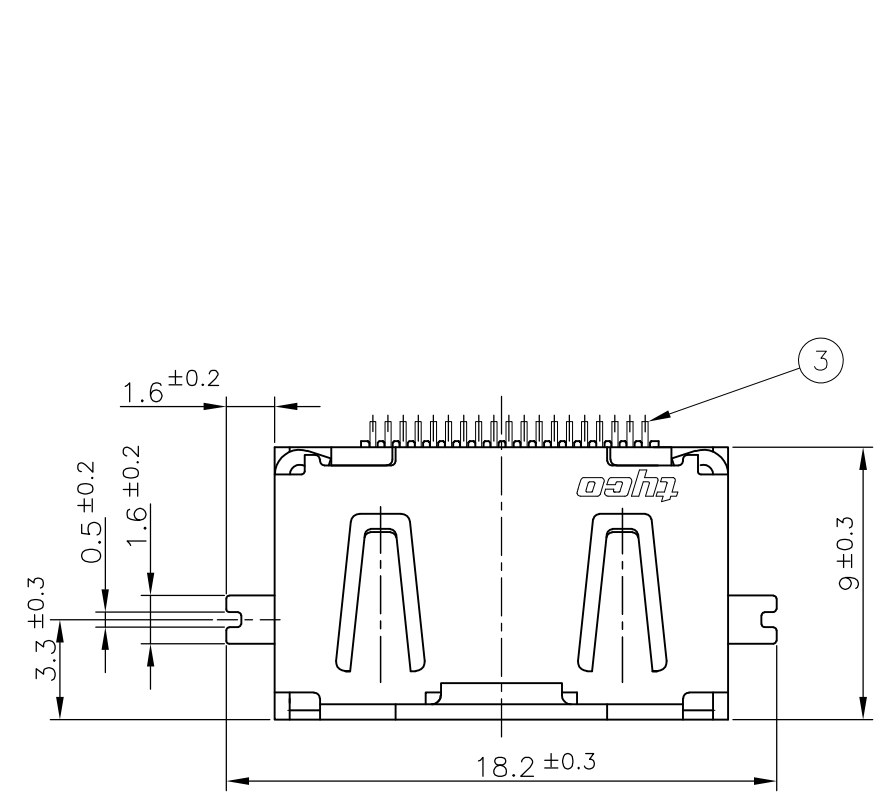

P.C.B LAYOUT (REFERENCE)
 SHOWN AS CONNECTOR MOUNTING SIDE
 TOLERANCE: NON-CUMULATIVE

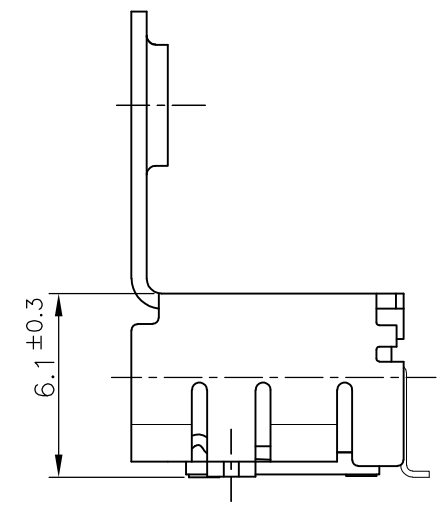
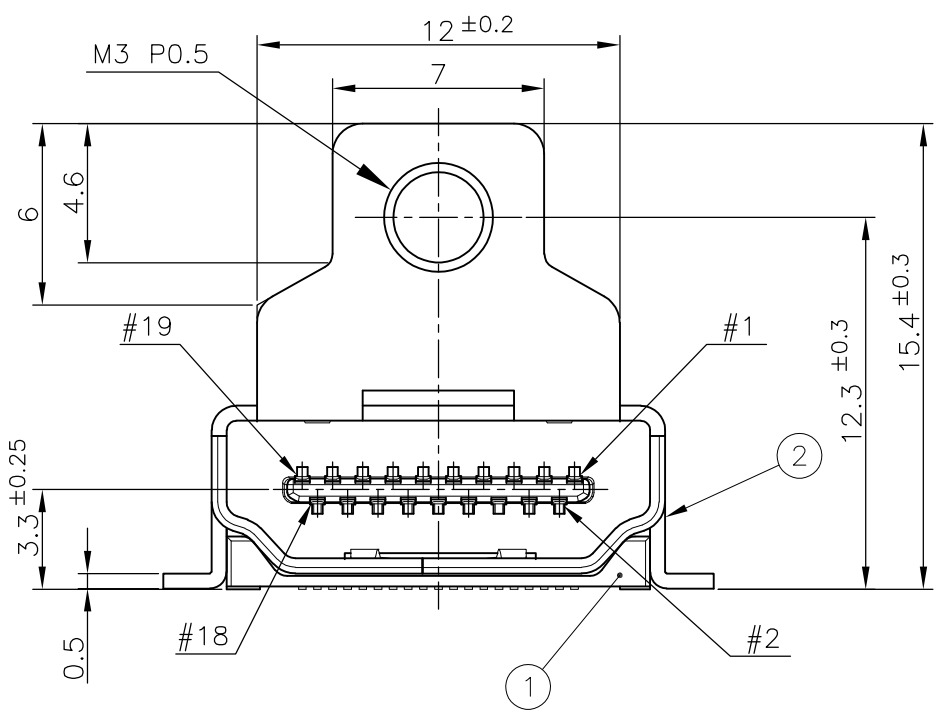

CONNECTOR: WITH FLANGE FULL SMT TYPE

BRASS	CONTACT	③
PHOSPHOR BRONZE	SHELL	②
GLASS FILLED LCP UL94V-0, BLACK COLOR	HOUSING	①
MATERIAL	DESCRIPTION	ITEM

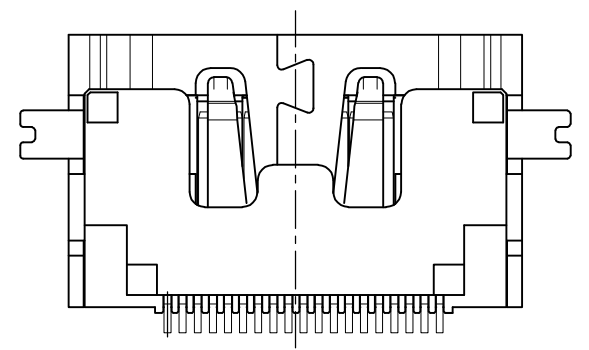

THIS DRAWING IS A CONTROLLED DOCUMENT.		DWN	Tyco Electronics Corporation Kawasaki, Japan		
DIMENSIONS: 単位: 耗 mm		CHK	NAME 名称		
TOLERANCES UNLESS OTHERWISE SPECIFIED: 一般公差		APVD	HDMI 19 POS RECEPTACLE ASSY SMT SHORT TYPE		
0 PLC ±		PRODUCT SPEC 製品規格	SIZE	CAGE CODE	DRAWING NO 番号
1 PLC ±		APPLICATION SPEC 取付適用規格	A3	00779	G-1903015
2 PLC ±		WEIGHT	RESTRICTED TO		
3 PLC ±			-		
4 PLC ±					
ANGLES ±					
FINISH 仕上		CUSTOMER DRAWING		SCALE 尺度 4:1	SHEET 5 OF 11
MATERIAL 材料				REV N	

THIS DRAWING IS UNPUBLISHED.

RELEASED FOR PUBLICATION SEP., 2005.

© COPYRIGHT 2005 BY TYCO ELECTRONICS CORPORATION. ALL RIGHTS RESERVED.

1903015-1, 2-1903015-2, 5-1903015-1
5-1903015-5, 7-1903015-1; AS SHOWN

LOC J
DIST

REVISIONS		DATE	DWN	APVD
変更				
P	LTR	DESCRIPTION		
	-	SEE SHEET 1	-	-

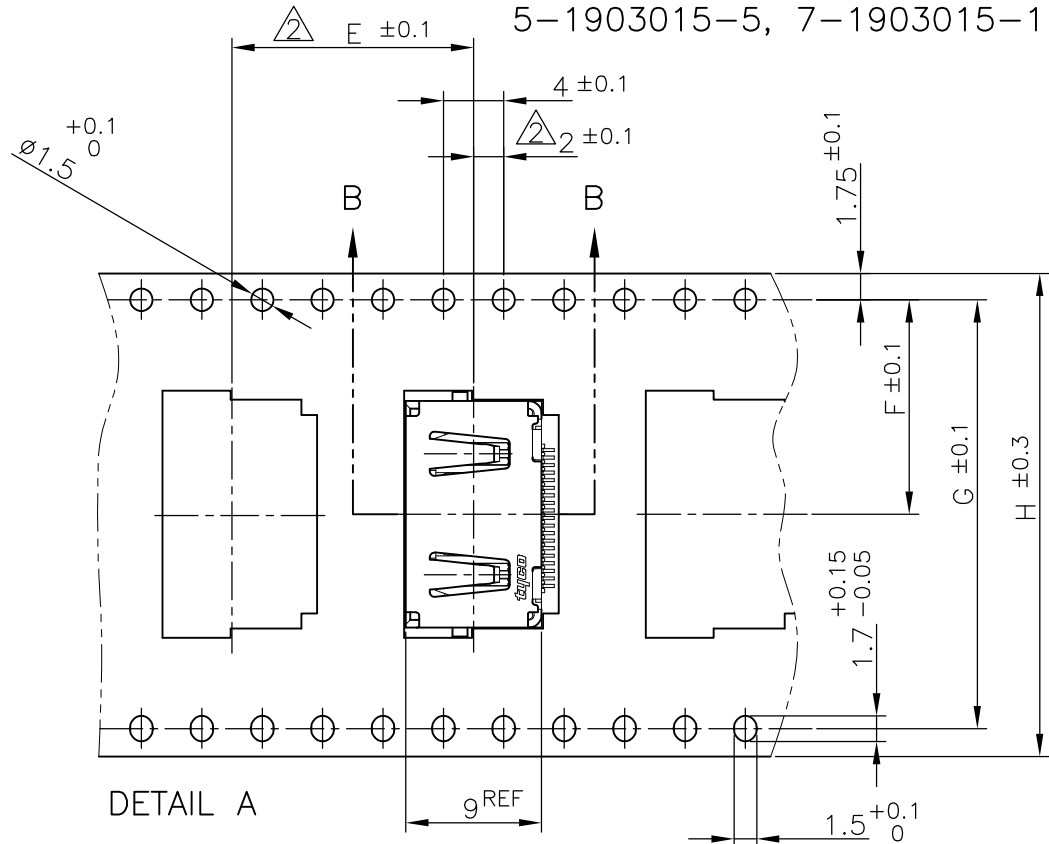

5-1903015-3; AS SHOWN (SCALE 1:1)

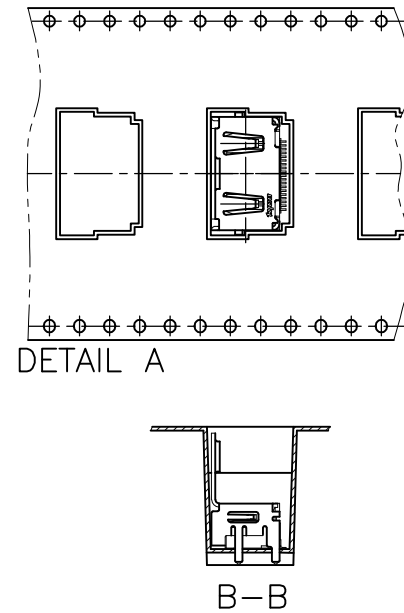

5-1903015-9; AS SHOWN (SCALE 1:1)

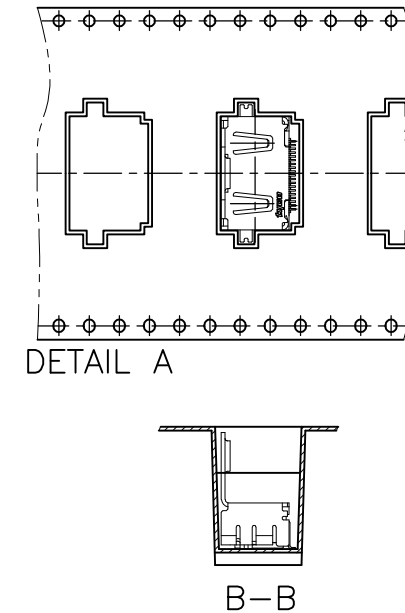

9-1903015-3; AS SHOWN (SCALE 1:1)

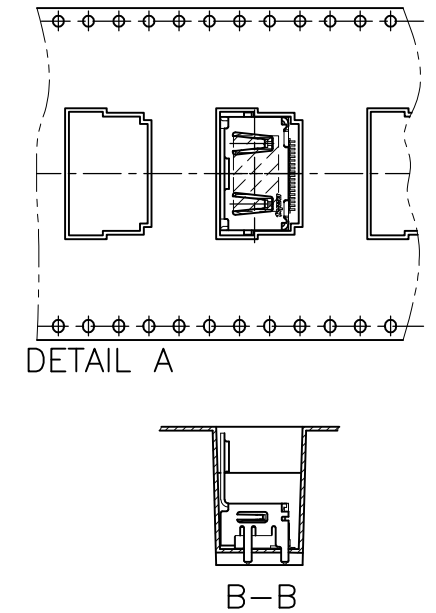

1903015-3; AS SHOWN (SCALE 1:1)

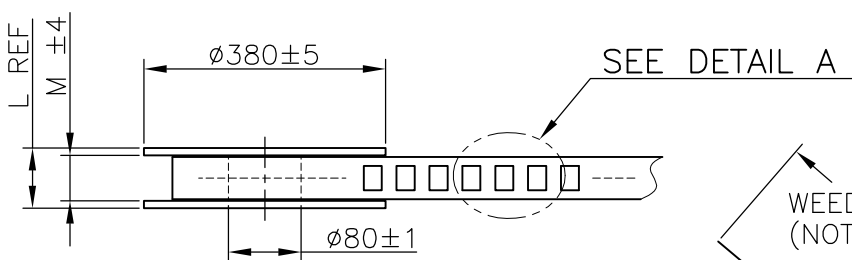
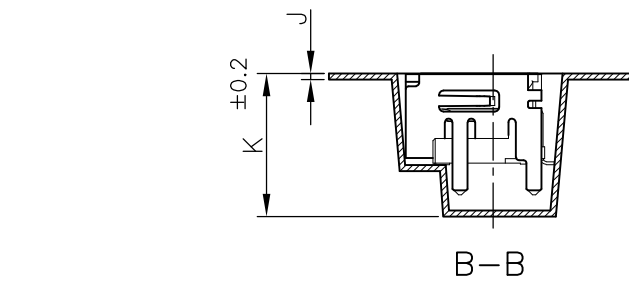
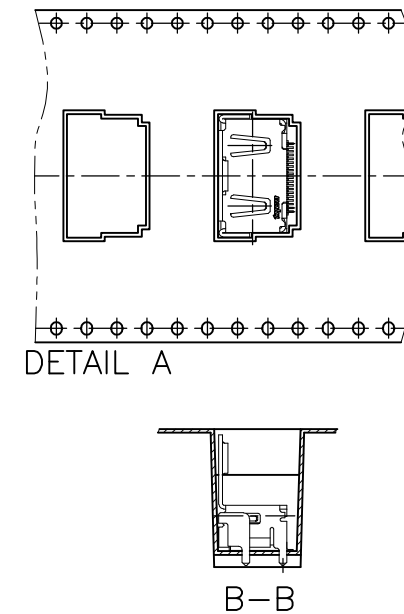

WEEDING THE COVER TAPE: 300 MIN (NOT INCLUDE EMPTINESS POCKET)

PELLING ANGLE: 165°~180°
PEELING STRENGTH: 0.1~0.7N (300mm/min.)

△ LABEL DESCRIPTION

TYCO P/N: *-1903015-*
QTY: * pcs
D/C: MADE IN CHINA

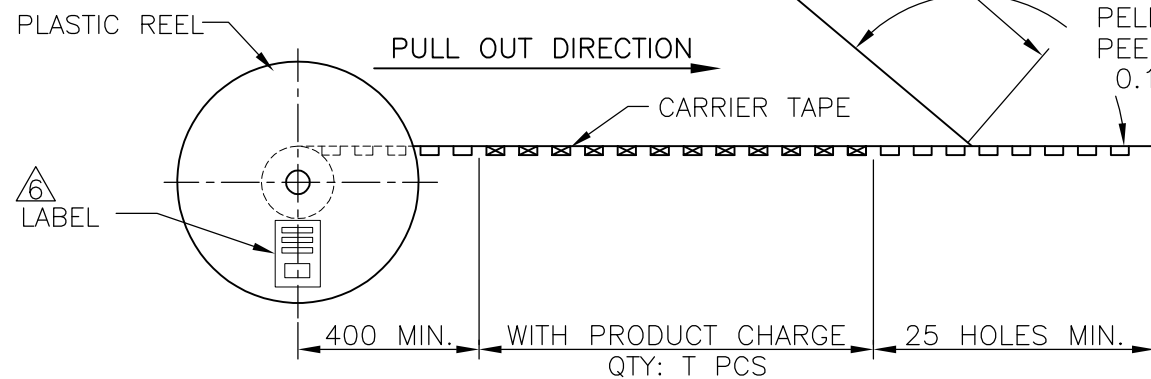

MATERIAL	DESCRIPTION
PET	COVER TAPE
PS	CARRIER TAPE
PLASTIC	REEL

THIS DRAWING IS A CONTROLLED DOCUMENT.		DWN	Tyco Electronics Tyco Electronics Corporation Kawasaki, Japan	
DIMENSIONS: 单位: 耗 mm		CHK	NAME 名称 HDMI 19 POS RECEPTACLE ASSY SMT SHORT TYPE	
TOLERANCES UNLESS OTHERWISE SPECIFIED: 一般公差		APVD	SIZE	RESTRICTED TO
0 PLC ±		PRODUCT SPEC 製品規格	CAGE CODE	
1 PLC ±		APPLICATION SPEC 取付適用規格	DRAWING NO 番号	
2 PLC ±		WEIGHT	A3	
3 PLC ±		CUSTOMER DRAWING	00779	
4 PLC ±			G-1903015	
ANGLES ±			SCALE 尺度 4:1	SHEET 6 of 11
FINISH 仕上				REV N

THIS DRAWING IS UNPUBLISHED. RELEASED FOR PUBLICATION SEP , 2005.
 © COPYRIGHT 2005 BY TYCO ELECTRONICS CORPORATION. ALL RIGHTS RESERVED.

LOC	DIST	REVISIONS					
J	/	P	LTR	DESCRIPTION	DATE	DWN	APVD
		-		SEE SHEET 1	-	-	-

1903015-2, 1903015-5, 4-1903015-1, 5-1903015-2, 5-1903015-4
 8-1903015-4, 9-1903015-4; AS SHOWN

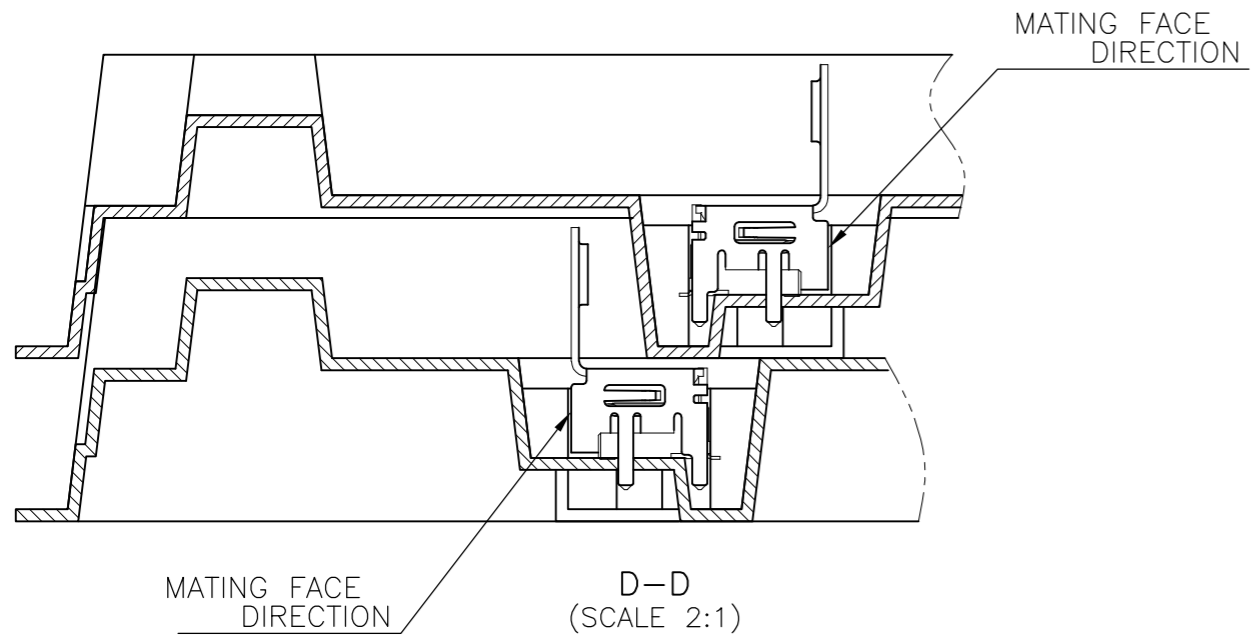
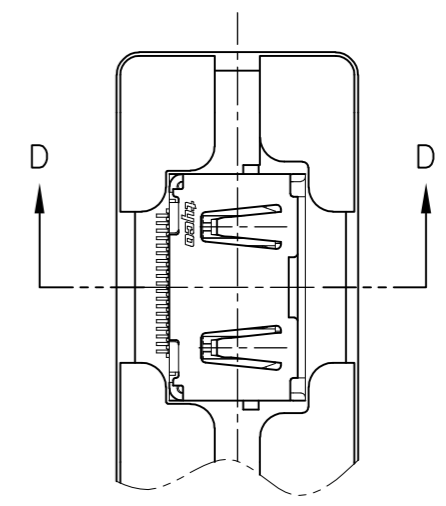
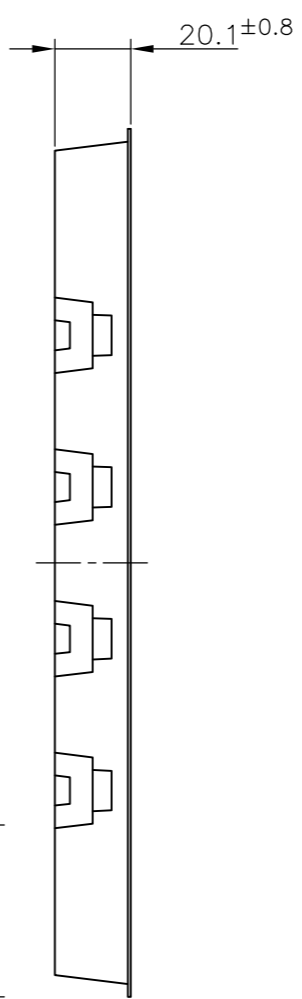
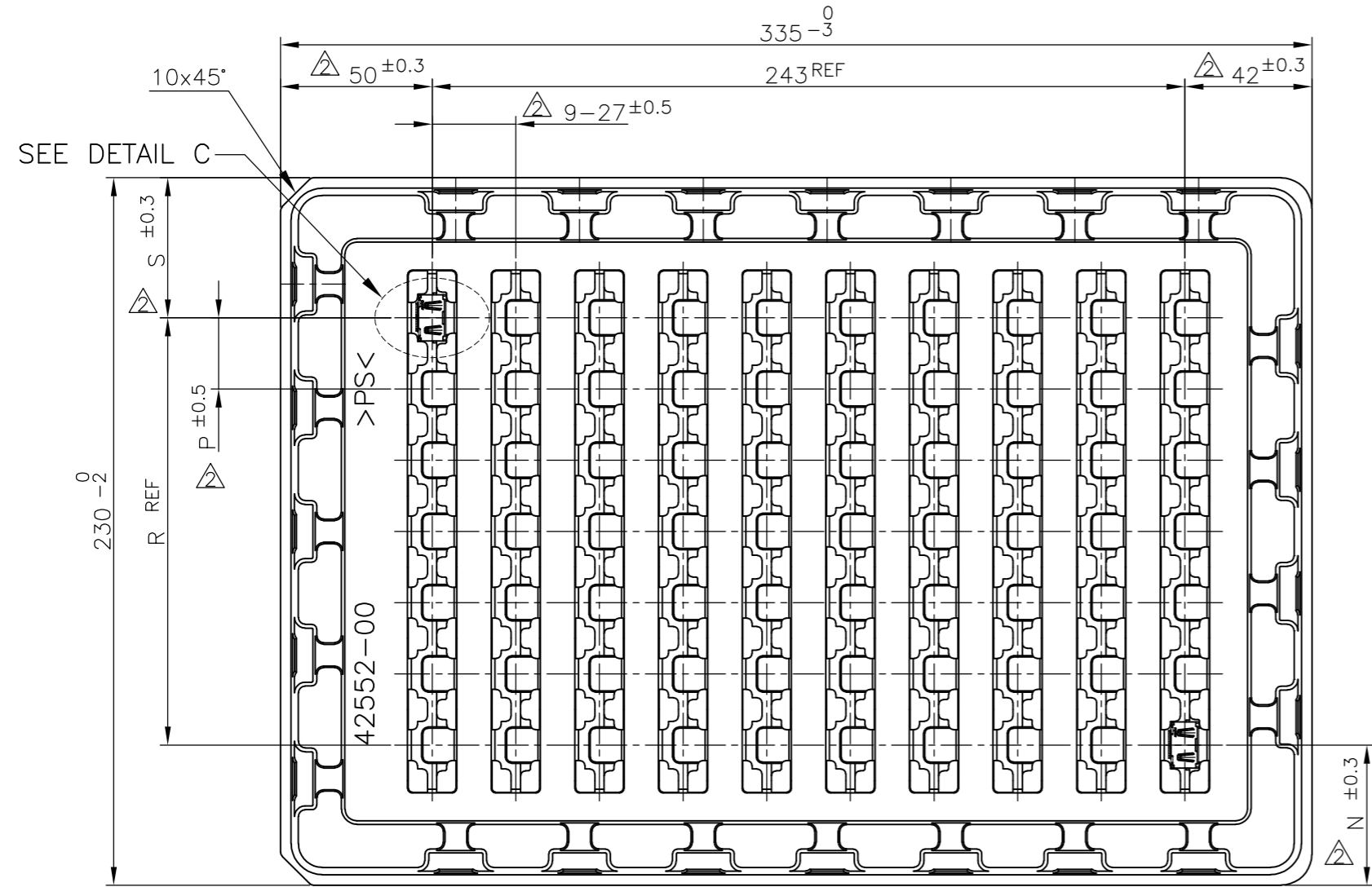

THIS DRAWING IS A CONTROLLED DOCUMENT.		DWN		Tyco Electronics		Tyco Electronics Corporation	
DIMENSIONS: 单位: 耗 mm		CHK		NAME 名称		Kawasaki, Japan	
TOLERANCES UNLESS OTHERWISE SPECIFIED: 一般公差		APVD		PRODUCT SPEC 製品規格		HDMI 19 POS RECEPTACLE ASSY SMT SHORT TYPE	
0 PLC ±		APPLICATION SPEC 取付適用規格		SIZE		RESTRICTED TO	
1 PLC ±		WEIGHT		CAGE CODE		-	
2 PLC ±		CUSTOMER DRAWING		DRAWING NO 番号		SCALE 尺度 4:1	
3 PLC ±				A3 00779 C-1903015		SHEET 7 OF 11	
4 PLC ±						REV N	
ANGLES ±							
FINISH 仕上							
MATERIAL 材料							

4

3

2

1

THIS DRAWING IS UNPUBLISHED. RELEASED FOR PUBLICATION SEP, 2005.
 © COPYRIGHT 2005 BY TYCO ELECTRONICS CORPORATION. ALL RIGHTS RESERVED.

LOC	DIST	REVISIONS					
		P	LTR	DESCRIPTION	DATE	DWN	APVD
J	/		-	SEE SHEET 1	-	-	-

1903015-4; AS SHOWN

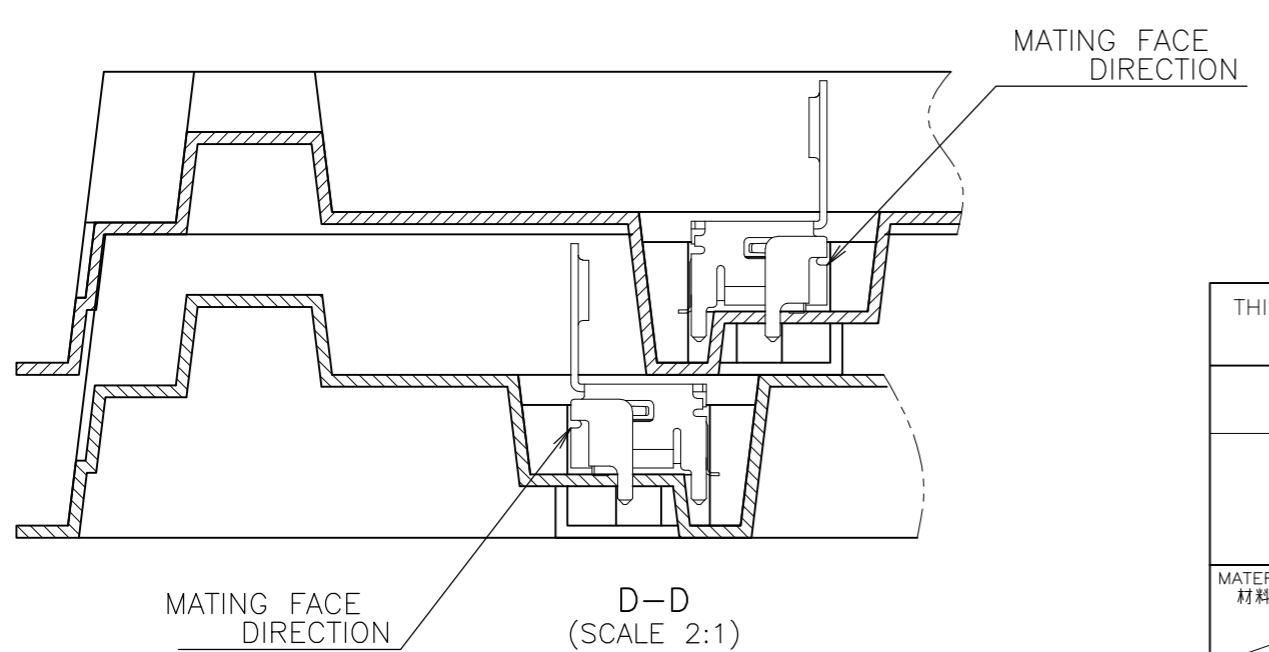
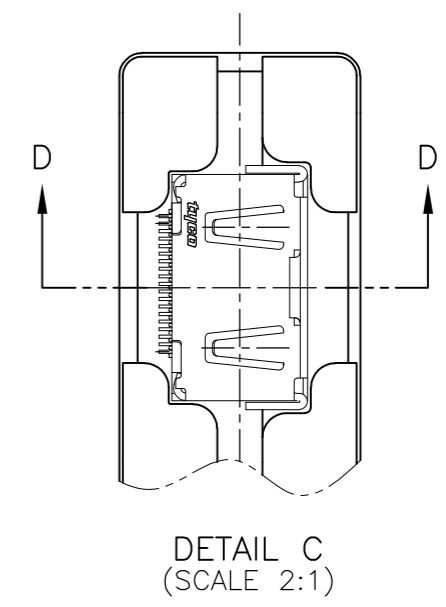
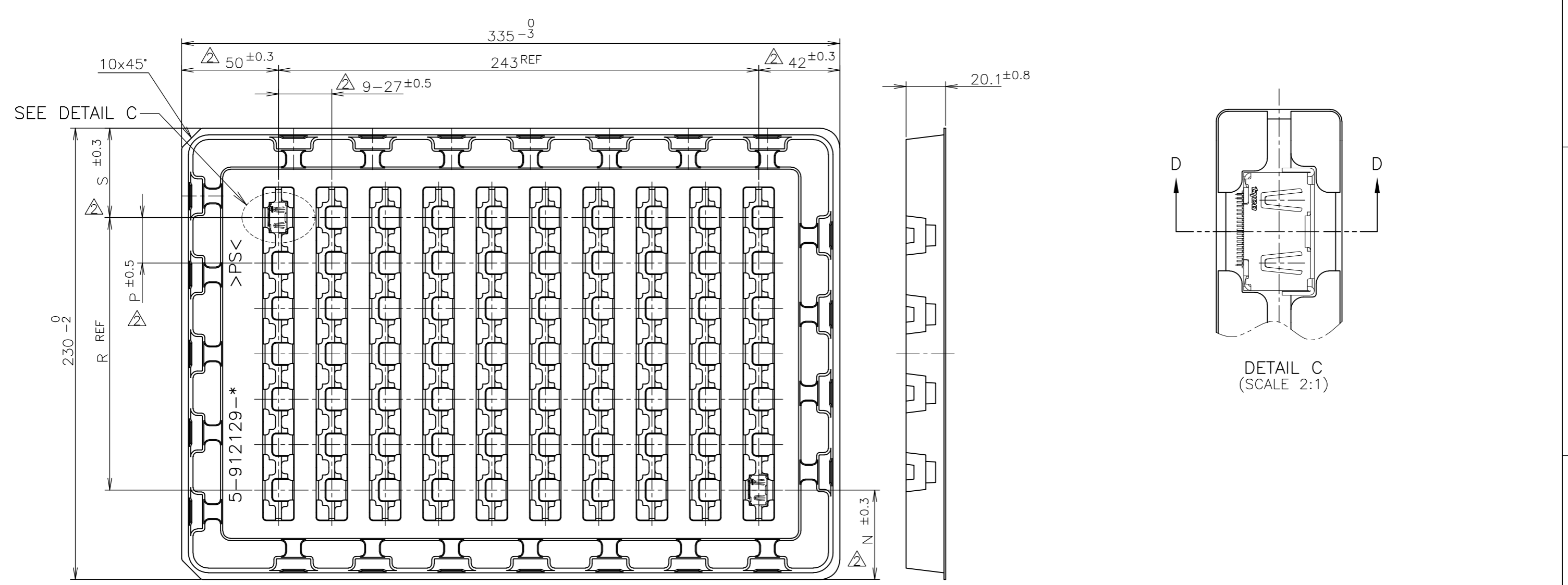

THIS DRAWING IS A CONTROLLED DOCUMENT.		DWN	Tyco Electronics Corporation Kawasaki, Japan		
DIMENSIONS: 単位: 耗 mm		CHK	NAME 名称		
TOLERANCES UNLESS OTHERWISE SPECIFIED: 一般公差		APVD	HDMI 19 POS RECEPTACLE ASSY SMT SHORT TYPE		
0 PLC ±		PRODUCT SPEC 製品規格	SIZE	CAGE CODE	DRAWING NO 番号
1 PLC ±		APPLICATION SPEC 取付適用規格	A3	00779	C-1903015
2 PLC ±		WEIGHT	RESTRICTED TO		
3 PLC ±		CUSTOMER DRAWING	-		
4 PLC ±			SCALE 尺度	SHEET	REV
ANGLES ±			4:1	8 OF 11	N
FINISH 仕上					

1903015-7, 1903015-8; AS SHOWN

LOC	DIST	REVISIONS			
J		変更			
P	LTR	DESCRIPTION	DATE	DWN	APVD
	-	SEE SHEET 1	-	-	-

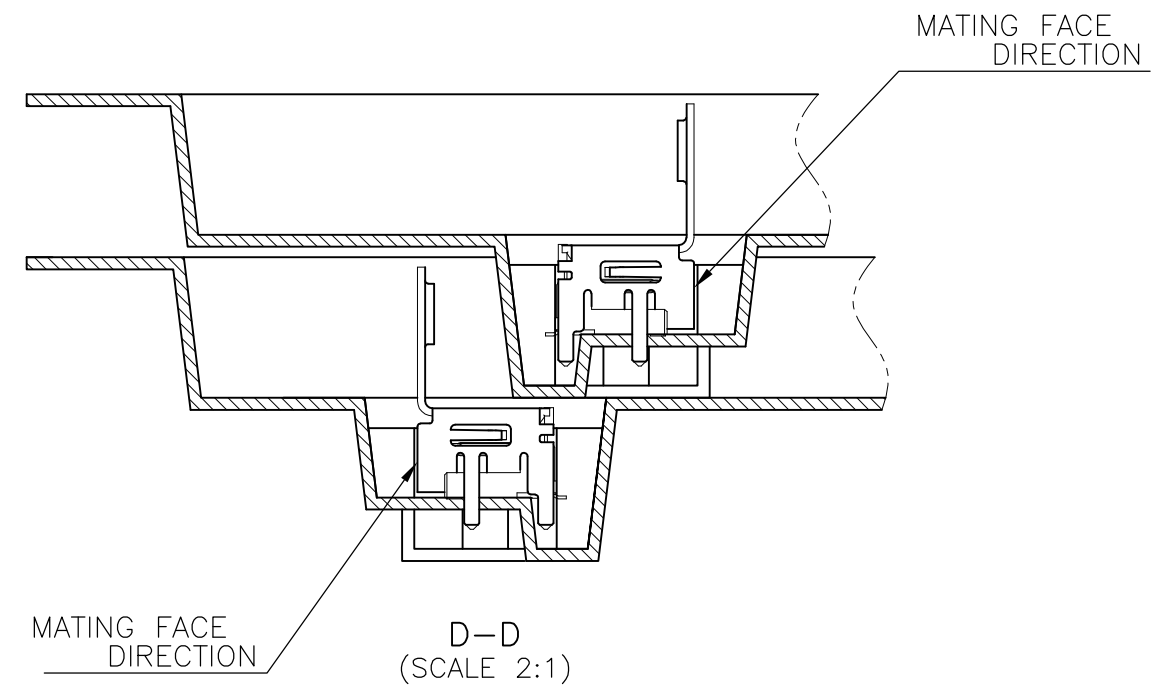
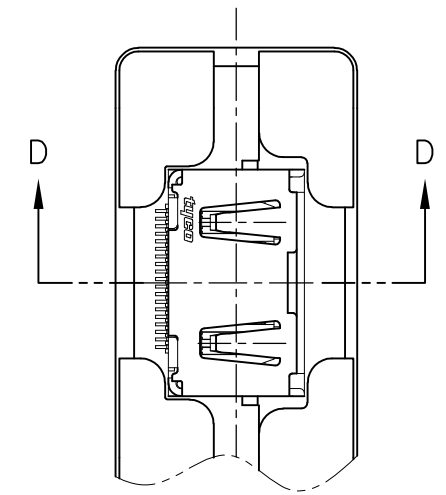
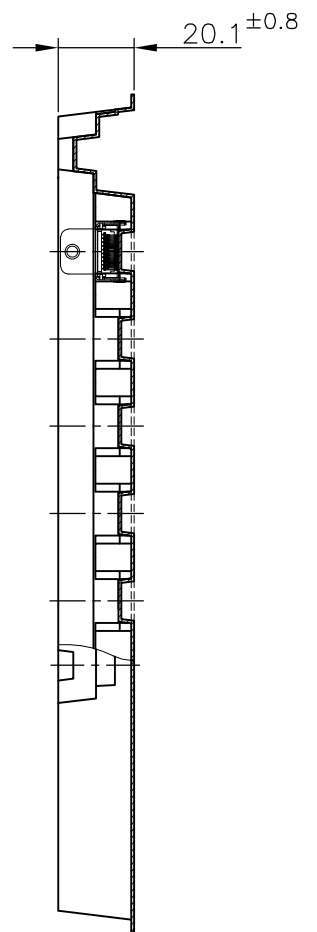
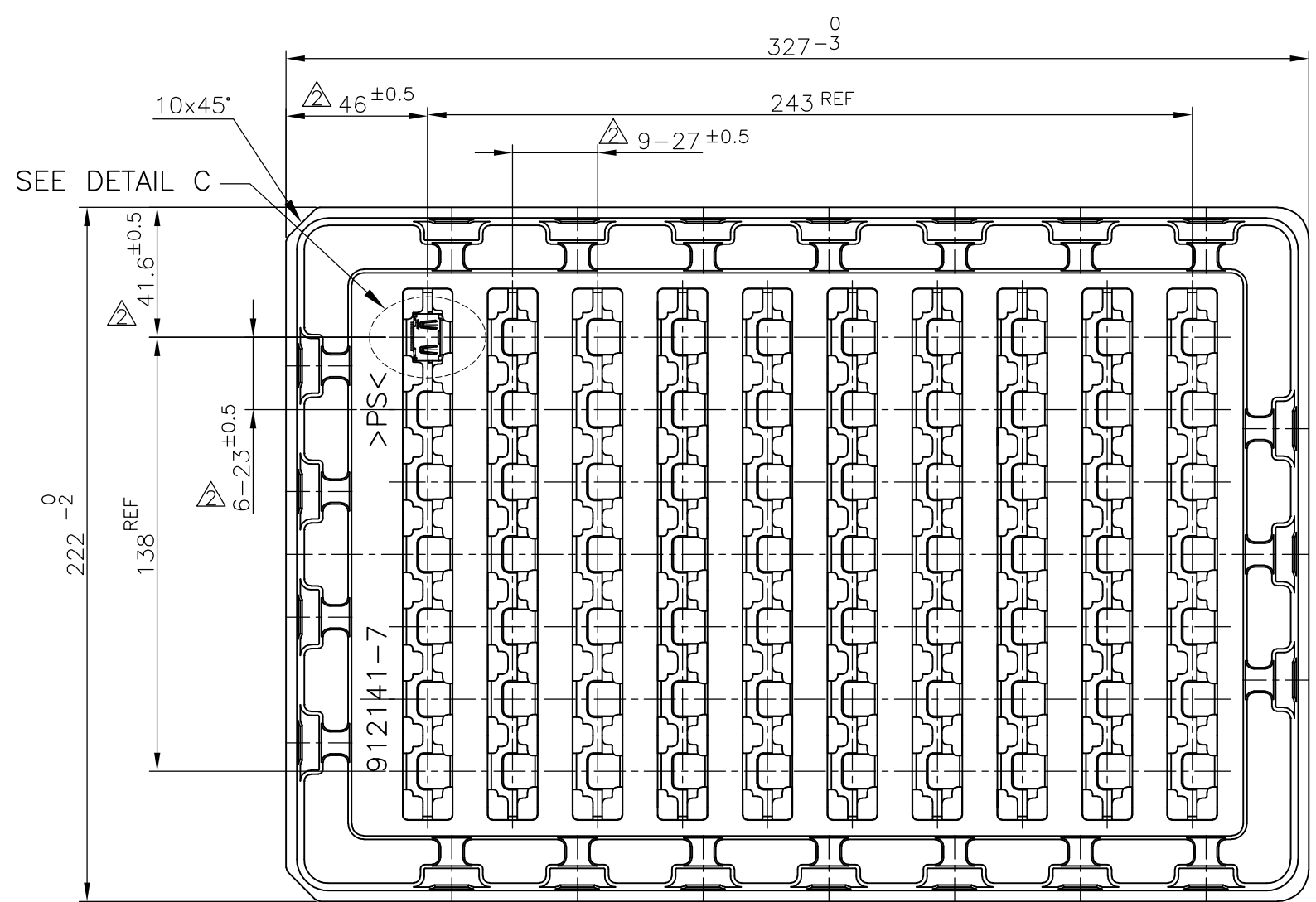

THIS DRAWING IS A CONTROLLED DOCUMENT.

DIMENSIONS: 単位: 耗 mm	TOLERANCES UNLESS OTHERWISE SPECIFIED: 一般公差
	0 PLC ±
	1 PLC ±
	2 PLC ±
	3 PLC ±
	4 PLC ±
	ANGLES ±

MATERIAL
材料

FINISH
仕上

DWN	CHK	APVD	PRODUCT SPEC 製品規格	APPLICATION SPEC 取付適用規格	WEIGHT
-----	-----	------	----------------------	----------------------------	--------

Tyco Electronics		Tyco Electronics Corporaion Kawasaki, Japan	
NAME 名称		HDMI 19 POS RECEPTACLE ASSY SMT SHORT TYPE	
SIZE	CAGE CODE	DRAWING NO 番号	RESTRICTED TO
A3	00779	G-1903015	-

CUSTOMER DRAWING

PS	TRAY
MATERIAL	DESCRIPTION

SCALE 尺度	SHEET	REV
4:1	9 of 11	N

THIS DRAWING IS UNPUBLISHED. RELEASED FOR PUBLICATION SEP, 2005.
 © COPYRIGHT 2005 BY TYCO ELECTRONICS CORPORATION. ALL RIGHTS RESERVED.

LOC J	DIST /	REVISIONS 変更			
P	LTR	DESCRIPTION	DATE	DWN	APVD
-	-	SEE SHEET 1	-	-	-

8-1903015-4; AS SHOWN

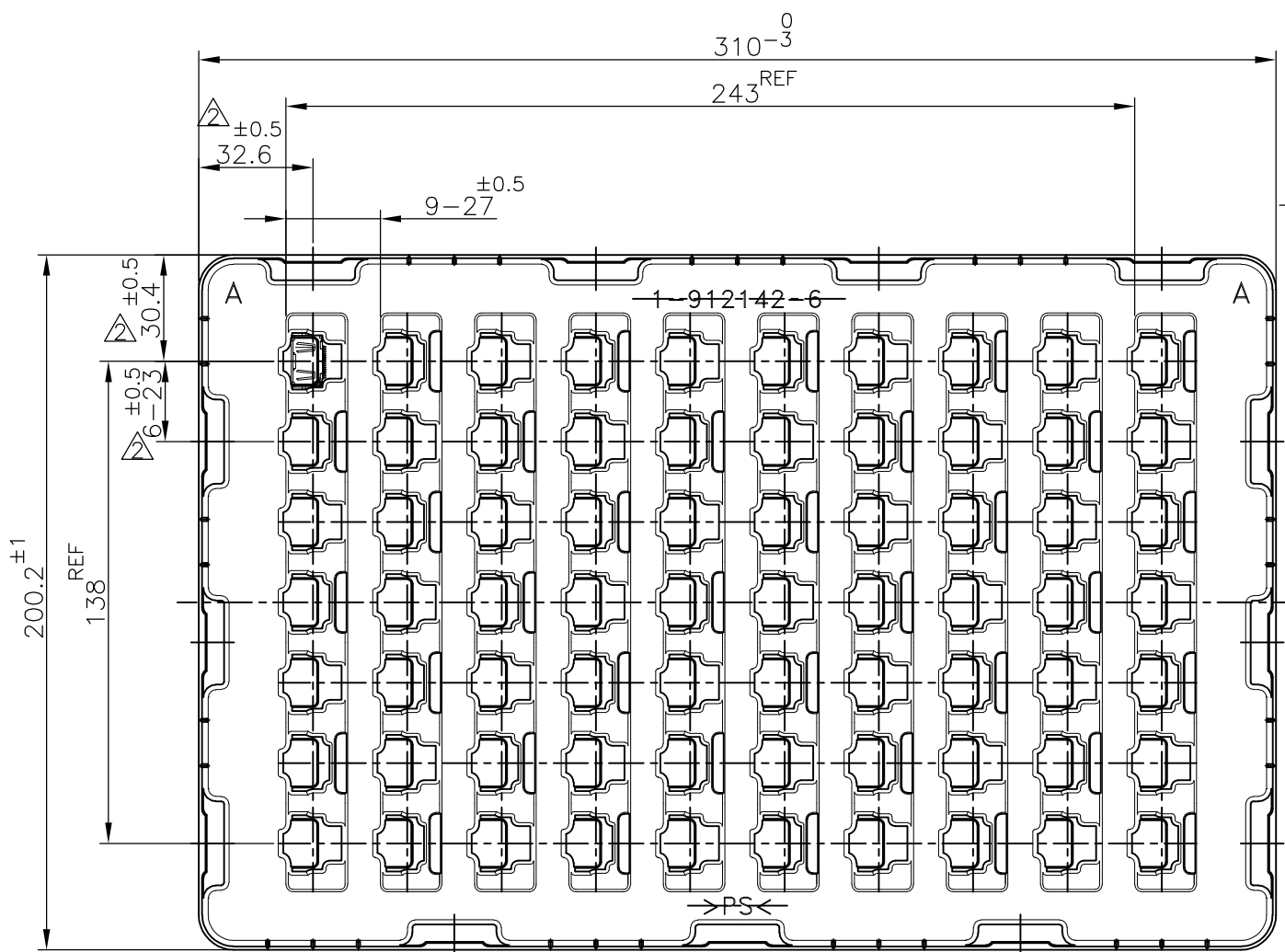

TRAY A

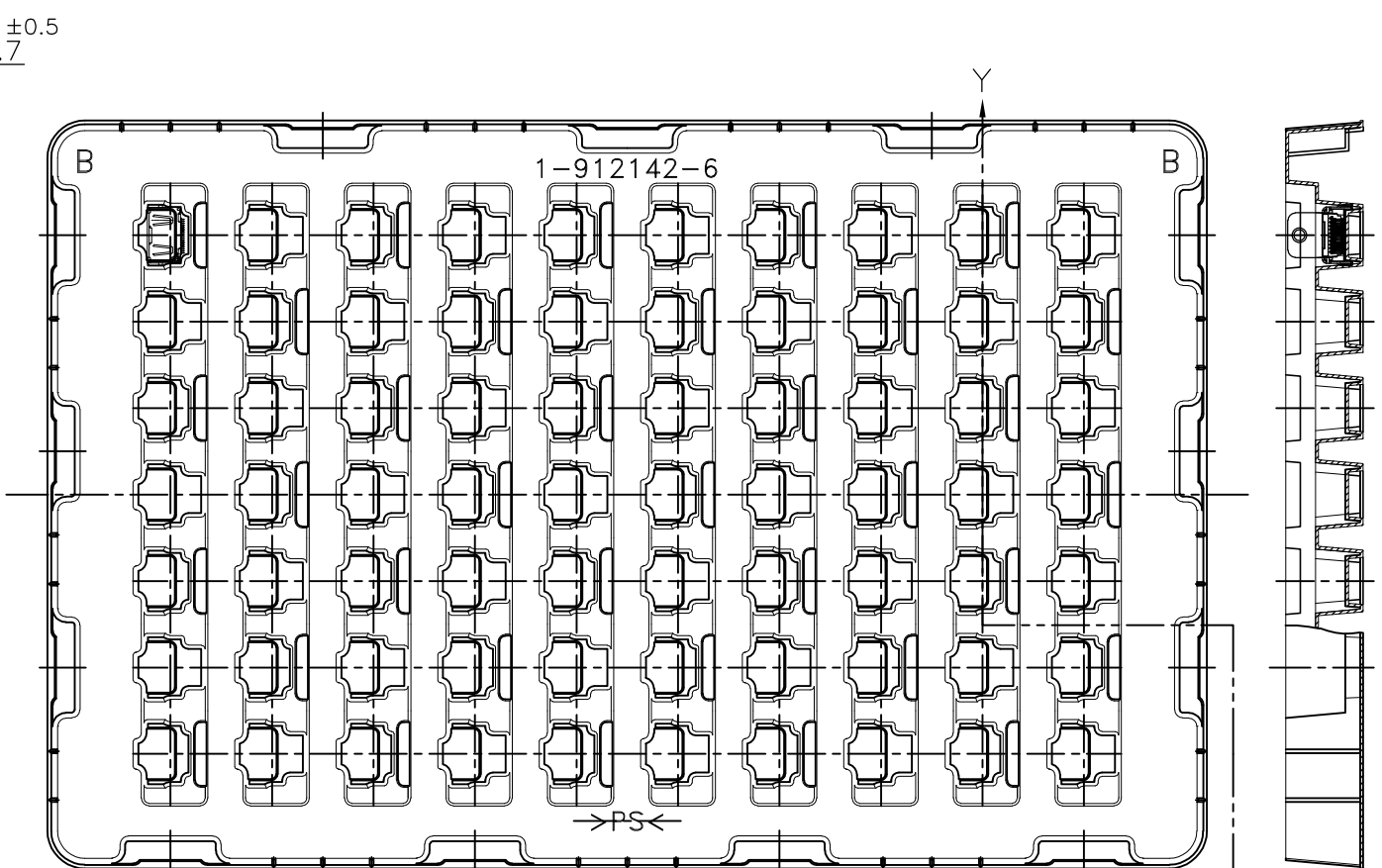

TRAY B

TRAY B (EMPTY)

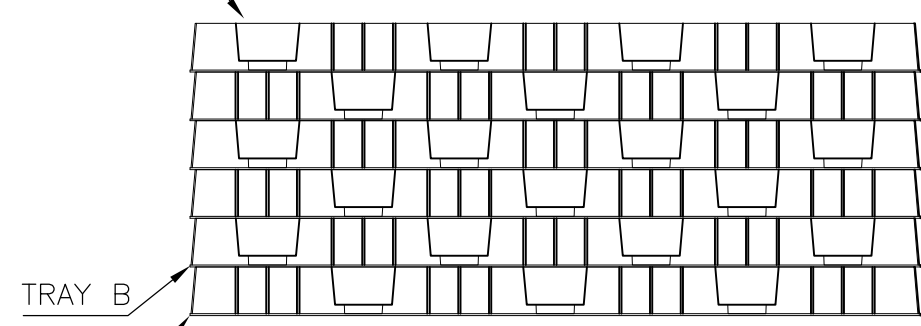

TRAY B

TRAY A

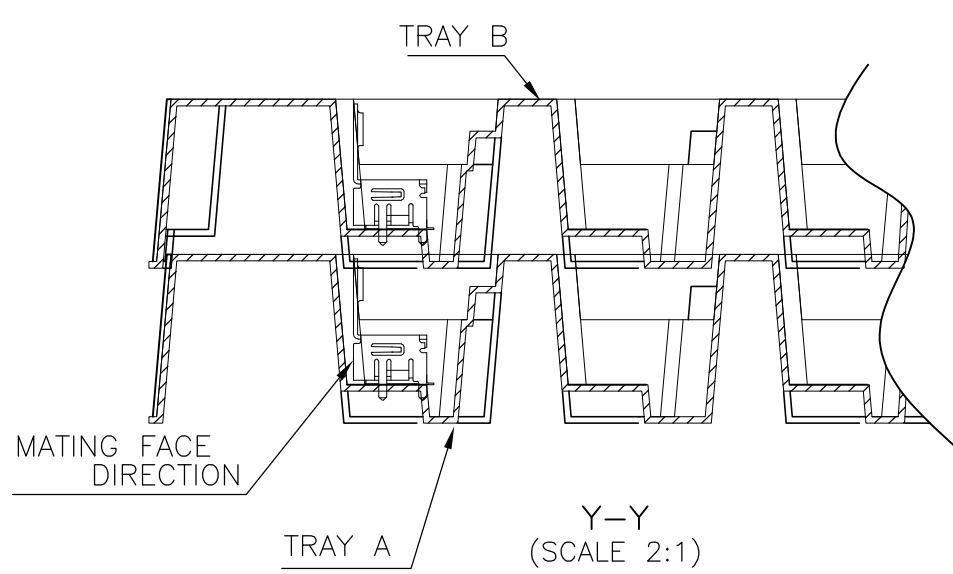

Y-Y
(SCALE 2:1)

PS	TRAY
MATERIAL	DESCRIPTION

THIS DRAWING IS A CONTROLLED DOCUMENT.		DWN	Tyco Electronics Tyco Electronics Corporation Kawasaki, Japan	
DIMENSIONS: 単位: 耗 mm		CHK	NAME 名称	
TOLERANCES UNLESS OTHERWISE SPECIFIED: 一般公差		APVD	HDMI 19 POS RECEPTACLE ASSY SMT SHORT TYPE	
0 PLC ±		PRODUCT SPEC 製品規格	SIZE	CAGE CODE
1 PLC ±		APPLICATION SPEC 取付適用規格	A3	00779
2 PLC ±		WEIGHT	DRAWING NO 番号	
3 PLC ±		CUSTOMER DRAWING	G-1903015	
4 PLC ±		SCALE 尺度 4:1	RESTRICTED TO	
ANGLES ±		SHEET 10 of 11	REV N	
FINISH 仕上				

THIS DRAWING IS UNPUBLISHED. RELEASED FOR PUBLICATION SEP, 2005.
 © COPYRIGHT 2005 BY TYCO ELECTRONICS CORPORATION. ALL RIGHTS RESERVED.

LOC		DIST		REVISIONS			DATE	DWN	APVD
J		/		P	LTR	DESCRIPTION			
						SEE SHEET 1	-	-	-

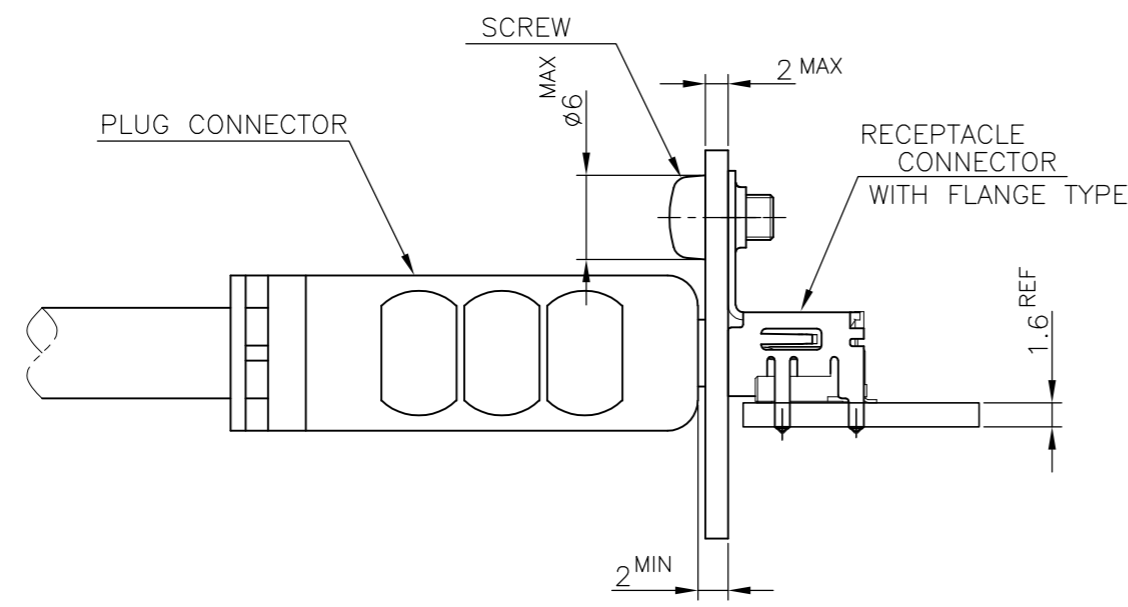
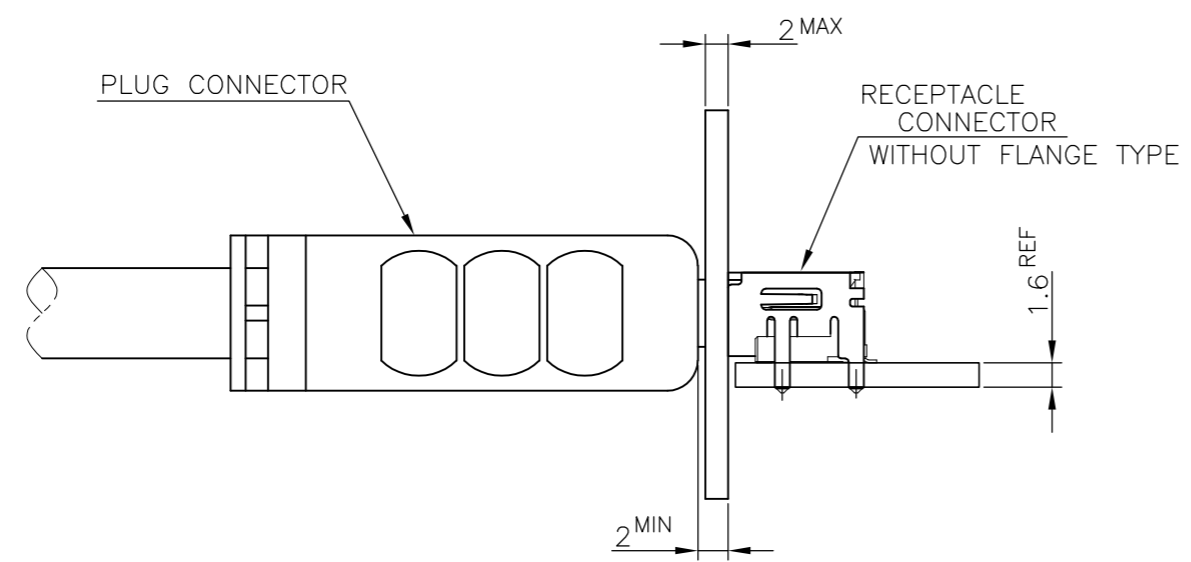

MATING CONDITION (REFERENCE)
(SCALE 2:1)

THIS DRAWING IS A CONTROLLED DOCUMENT.		DWN		Tyco Electronics		Tyco Electronics Corporation	
DIMENSIONS: 単位: 耗 mm		TOLERANCES UNLESS OTHERWISE SPECIFIED: 一般公差		CHK		Kawasaki, Japan	
		0 PLC ±		APVD		NAME 名称	
		1 PLC ±		PRODUCT SPEC 製品規格		HDMI 19 POS RECEPTACLE ASSY	
MATERIAL 材料		2 PLC ±		APPLICATION SPEC 取付適用規格		SMT SHORT TYPE	
		3 PLC ±		WEIGHT		SIZE	
		4 PLC ±		CUSTOMER DRAWING		CAGE CODE	
		ANGLES ±				DRAWING NO 番号	
		FINISH 仕上				A3 00779 C-1903015	
						RESTRICTED TO	
						SCALE 尺度 4:1	
						SHEET 11 OF 11	
						REV N	