

HC-B 24-TMS-100/O1STM32S-EMV

Order No.: 1690383

<http://eshop.phoenixcontact.de/phoenix/treeViewClick.do?UID=1690383>HEAVYCON ADVANCE EMV sleeve housing B24, with screw locking,
height 100 mm, with 1xM32 thread, lateral cable outlet

Commercial data	
GTIN (EAN)	 4 017918 822538
sales group	D201
Pack	10 pcs.
Customs tariff	85389099
Catalog page information	Page 479 (PC-2009)

Product notes

WEEE/RoHS-compliant since:
01/31/2006

<http://www.download.phoenixcontact.com>
Please note that the data given here has been taken from the online catalog. For comprehensive information and data, please refer to the user documentation. The General Terms and Conditions of Use apply to Internet downloads.

Technical data

General data	
Note	For contact inserts HC-B24, BB46, D64, DD108, HV10/16, M
Design	B24
Height	100 mm
Width	57 mm
Length	152 mm

Housing type	Sleeve housings
Locking type	Screw locking
Torque	3 Nm (Locking screw)
Fixing screws	M6
Cable exit	Lateral
Type of the screw connection	1x M32
Degree of protection	IP65 / IP68 (0.2 bar, 24h) / IP69K
Ambient temperature (operation)	-40 °C ... 125 °C
Housing material	Aluminum, die-cast
Housing surface material	EMC coating, silver
Seal material	NBR, conductive
Material lock	High-grade steel
Length of the assembly cutout	112 mm
Width of the assembly cutout	35 mm
Connection	If insulating powder coating is present on the control cabinet panel, it should be removed from the profile gasket area in order to ensure optimum shielding.

Certificates / Approvals



Certification GOST

Accessories

Item	Designation	Description
Assembly		
1686533	HC-B-AF	Panel mounting flange for HEAVYCON-ADVANCE TMS housing with screw locking
1604638	HC-B-AF-SET	Panel mounting flange for screw locking, set comprising 2 panel mounting flanges with 4 self-tapping Torx head screws and 4 fan-type washers

General

1690765	HC-B 24-TMS-SD-IP50	HEAVYCON ADVANCE IP50 protective cover B24, for panel mounting side, with clip locking, with retaining cord, diameter of retaining cord eyelet 3 mm
1690804	HC-B 24-TMS-SD-IP65	HEAVYCON ADVANCE B24 IP65 protective cover, for panel mounting side, with screw locking, with retaining cord, diameter of retaining cord eyelet: 3 mm

Diagrams/Drawings

Dimensioned drawing

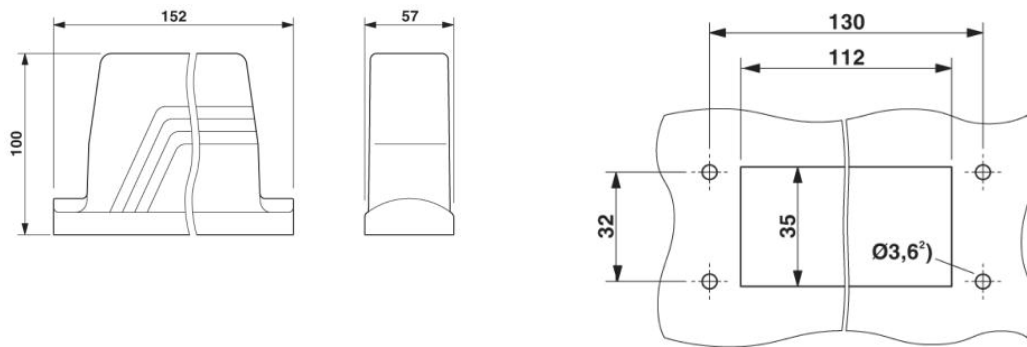

Panel cutout

²⁾ When self-tapping Torx screws are used (Torx20, M4)

Address

PHOENIX CONTACT Inc., USA
586 Fulling Mill Road
Middletown, PA 17057, USA
Phone (800) 888-7388
Fax (717) 944-1625
<http://www.phoenixcon.com>



© 2011 Phoenix Contact
Technical modifications reserved;