

DO NOT SCALE  
DIMENSIONS IN mm

METRIC

THIRD ANGLE  
PROJECTION

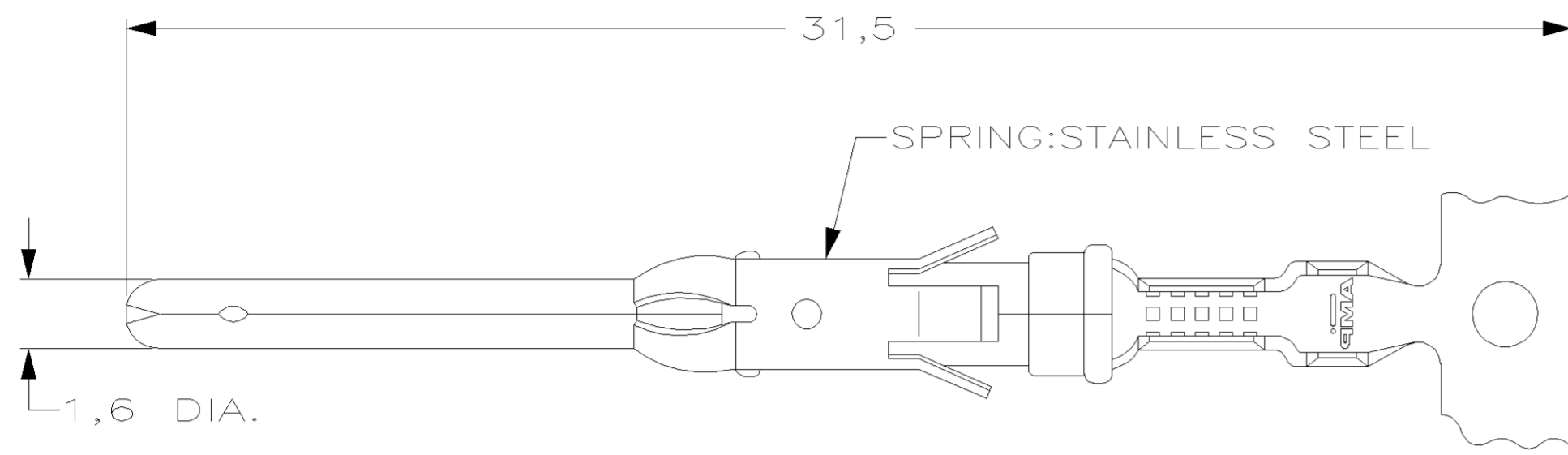
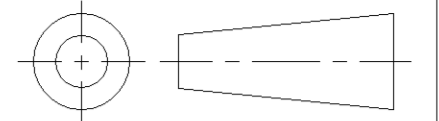

STRIP

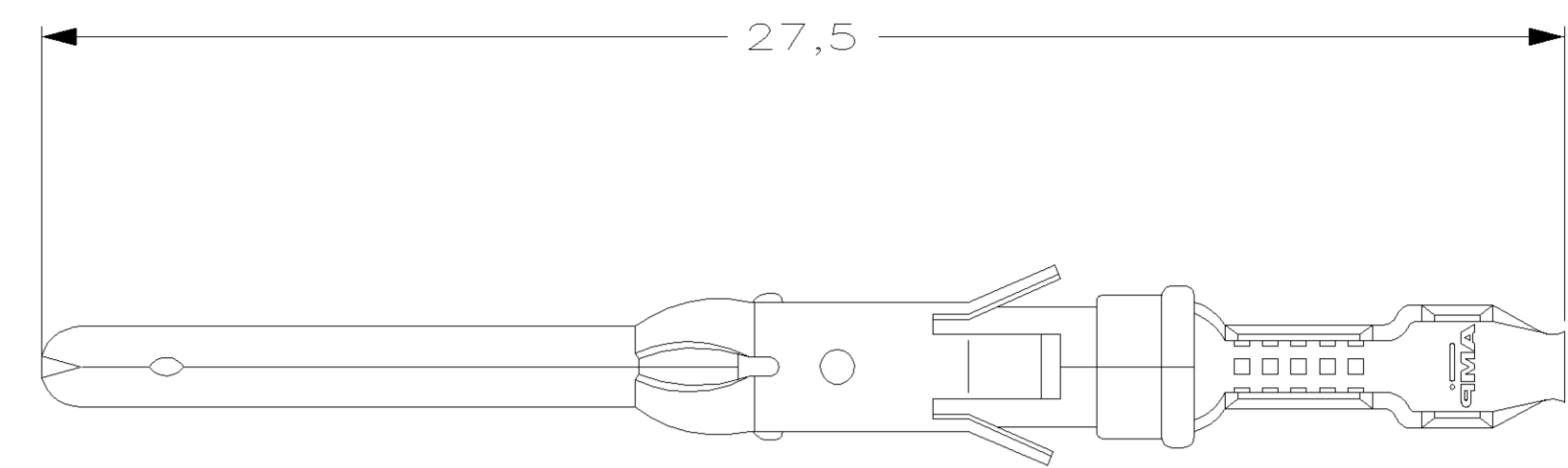

LOOSE-PIECE

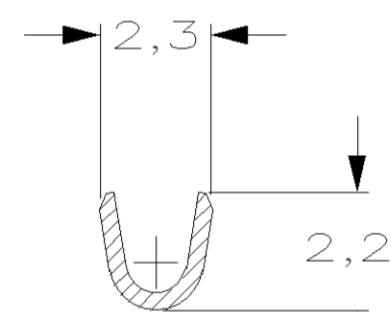
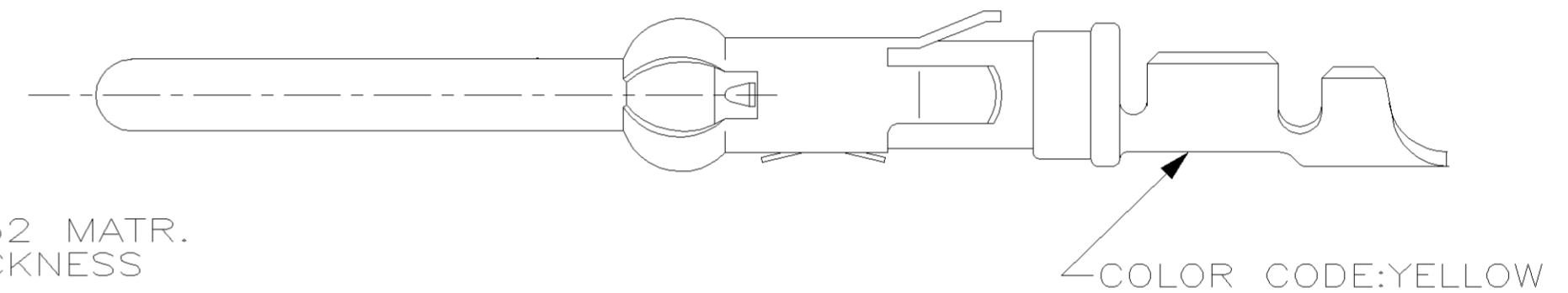
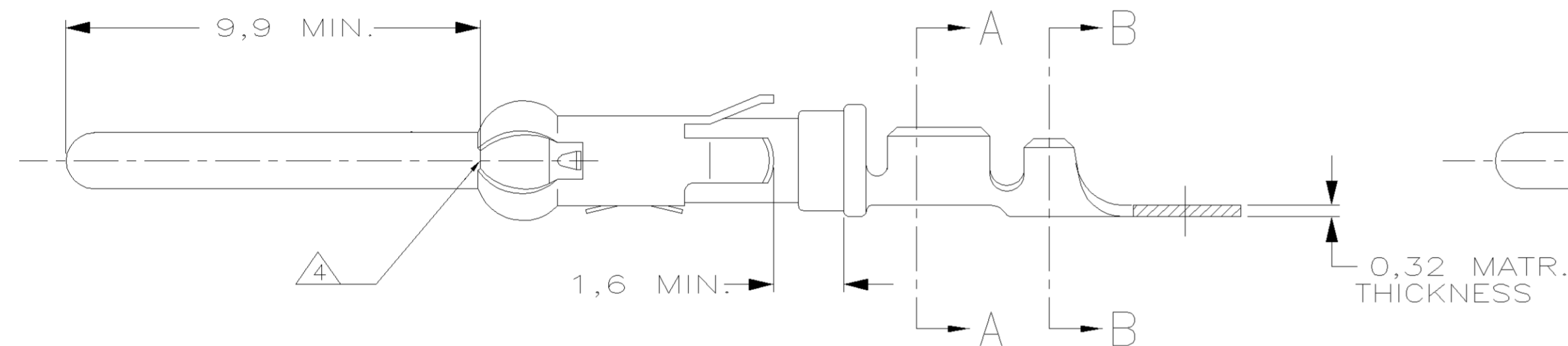

SECTION A-A

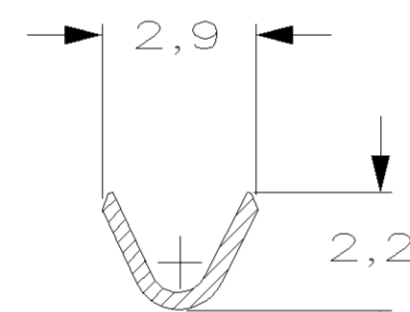

SECTION B-B

WIRE RANGE : 0,20-0,50 mm? (24-20 AWG)  
INSUL. RANGE : 1,1 -1,8 mm (.045-.070)

	1-163085-4	△1	△A	1-163086-1	BRASS	EL.TIN	△31	△20
	1-163085-3		△A	1-163086-3	BRASS	BR. TIN		△30
△32 OBSOLETE	<del>5-163085-3</del>	△5	△C		BRASS	ECON.GOLD		△21
	5-163085-2	△1	△5		BRASS	SEL.GOLD		△22
△32 OBSOLETE	<del>5-163085-1</del>	△1	△5		BRASS	EL.TIN		△20
	1-163085-2		△B		BRASS	GOLD		△23
	1-163085-1		△A		BRASS	ECON.GOLD		△21
	<del>1-163085-0</del>	△32	△B	1-163086-0	BRASS	ECON.GOLD		△21
	163085-9		△A		BRASS	EL.TIN		△20
	163085-8		△A		BRASS	SEL.GOLD		△22
	163085-2	△1	△B	163086-2	BRASS	SEL.GOLD		△22
	163085-1	△1	△B	163086-1	BRASS	EL.TIN		△20
	PARTNUMBER		DIRECTION OF REEL	LOOSE-PIECE	MATERIAL	PLATING		

AMPOMATOR + MINI-APPL. 107-3-FIG.1	△A
107-3-FIG.2	△B
107-3-FIG.4	△C

NOTES	MATERIAL	THICKNESS	AREA
△20	TIN	2,0 µm	ALL OVER
△21	NICKEL GOLD TIN	0,8 µm	ALL OVER CONTACT AREA BARREL
△22	NICKEL GOLD GOLD	0,8 µm	ALL OVER CONTACT AREA ALL OVER
△23	NICKEL GOLD GOLD	1,2 µm	ALL OVER CONTACT AREA ALL OVER
△27	NICKEL SILVER TIN	2,5 µm	ALL OVER CONTACT AREA BARREL
△28	SILVER	0,5 µm	ALL OVER
△29	SILVER	2,5 µm	ALL OVER
△30	NICKEL BRGHT TIN	1,27 µm 1,27 µm	ALL OVER ALL OVER
△31	LUBRICATED		

NOTES :

- △1 U.L.RECONIZED UNDER FILE E28476 VOL.VI SEC.I
- 2 FOR CRIMPDETAILS SEE AMP-SPEC. 114-19.000 .
- 3 MEETS PRODUCTSPECIFICATION 108-10042.
- △4 0,40 MAX. GAP BETWEEN SPRING-NOSE AND CONTACT BODY.
- △5 SPECIAL REEL WITH 200 PCS FOR REEL-FED HAND-TOOL
- △32 OBSOLETE PARTS: OBSOLETE CIS STREAMLINING PER D.RENAUD/D.SINISI

CUSTOMER DRAWING FOR REFERENCE ONLY  
WILL NOT BE UPDATED

THIS DRAWING IS UNPUBLISHED  
RELEASED FOR PUBLICATION 19



NAME

TYPE\_III\_PIN\_CONTACT  
SIZE\_16

AC2	REVISED PER ECO-11-005150	RK	HMR	28MAR11	
LTR.	REVISION RECORD	DR.	CHK.	DATE	
DR.:	-	CHK.:	-	APP.:	-
DATE:	-	DATE:	-	DATE:	-

DWG.No.	163085	REV.LTR.	AC2	SHEET	1 OF 1	A3
---------	--------	----------	-----	-------	--------	----