

10119130 - X0C - XXXLF

LEAD-FREE DESIGNATION ONLY WITH APPLICABLE PLATING CODES

LETTER	PLATING (SEE NOTE 6)	
	APPLICATION	TYPE (REFERENCE)
B	TELCORDIA CO	0.76µm GOLD or GXT
C	TELCORDIA UE	1.27µm GOLD
D	TELCORDIA CO	0.76µm GOLD or GXT, LEAD-FREE
E	TELCORDIA UE	1.27µm GOLD, LEAD-FREE

6-COLUMN DIFFERENTIAL SIGNAL

NUMBER	GUIDE PIN STYLE (SEE NOTE 8)
0	STANDARD GUIDE PIN, MACHINED
1	STANDARD GUIDE PIN, ROLLED

MODULE DESCRIPTION	LETTER DESIGNATION REPRESENTED IN DASH NUMBER										BASE MODULE
LEFT POLARIZING GUIDANCE MODULE (SEE SHEET 6)	N	J	A	B	C	D	E	F	G	H	
	NO KEY NO GUIDE PIN										
RIGHT POLARIZING GUIDANCE MODULE (SEE SHEET 7)	Z	Y	P	Q	R	S	T	U	V	W	
	NO KEY NO GUIDE PIN										
OPEN MODULE (TWO WALL) (SEE SHEET 2)	0 (ZERO)										
LEFT WALL MODULE (SEE SHEET 3)	L										
RIGHT WALL MODULE (SEE SHEET 4)	M										
FOUR WALL MODULE (SEE SHEET 5)	I (ONE)										

NUMBER	CONTACT MATING WIPE LENGTH		COMPLIANT TAIL TYPE (SEE NOTE 9)
	SIGNAL	GROUND	
1	2 MM	4 MM	0.55 (0.0217") DRILL
2	3 MM	4 MM	0.55 (0.0217") DRILL
3	2 MM	4 MM	0.45 MICRO (0.0177") DRILL
4	3 MM	4 MM	0.45 MICRO (0.0177") DRILL
5	2 MM	3 MM	0.55 (0.0217") DRILL
6	3 MM	3 MM	0.55 (0.0217") DRILL
7	2 MM	3 MM	0.45 MICRO (0.0177") DRILL
8	3 MM	3 MM	0.45 MICRO (0.0177") DRILL

FOR CUSTOM-LOADED MODULES, SEE INDIVIDUAL CUSTOM DRAWINGS WITH THE DRAWING-NUMBER FORMAT OF 10119130-XXXX, WHERE: "X" DENOTES MODULE TYPE PER CHART ON THIS SHEET "YYYY" IS A SEQUENTIAL NUMBER BEGINNING WITH "0001".

	UNGROUND	GROUND
FHS	Ø2.35-Ø2.55	Ø2.35-Ø2.55
PAD	N/A	Ø5.50
PLATED	NO	YES
DRILL(mm)	2.44mm	2.58mm
DRILL(in)	0.096"	0.1015"

SCREW P/N	DESCRIPTION	BOARD THICKNESS
10091790-002LF	#2-56 X 0.375" LG. PHILIPS PANHEAD W/SQ CONICAL WASHER	1.60-5.00mm
10091790-003LF	#2-56 X 0.375" LG. PHILIPS PANHEAD W/SQ CONICAL WASHER	5.00-10.00mm

spec ref	-	dr	Mary Glass	2012/02/09	projection	MM	size	A2	scale	2:1	
tolerance std	ASME Y14.5	eng	Sandar Soe	2013/03/20	chr	-	ecn no	ELX-8-1429-1			
	TOLERANCES UNLESS OTHERWISE SPECIFIED	appr	Chen-Hong Tan	2013/04/09	product family	XCEDE HD	rel level	Released			
surface	linear	0.X	±0.3								
		0.XX	±0.10								
		0.XXX	±0.05								
	angular	0°	±2°								
www.fci.com		FCj		TITLE		VERTICAL HEADER ASSEMBLY		10119130		rev	B
				cat. no.		Product - Customer Draw		sheet 1 of 8			

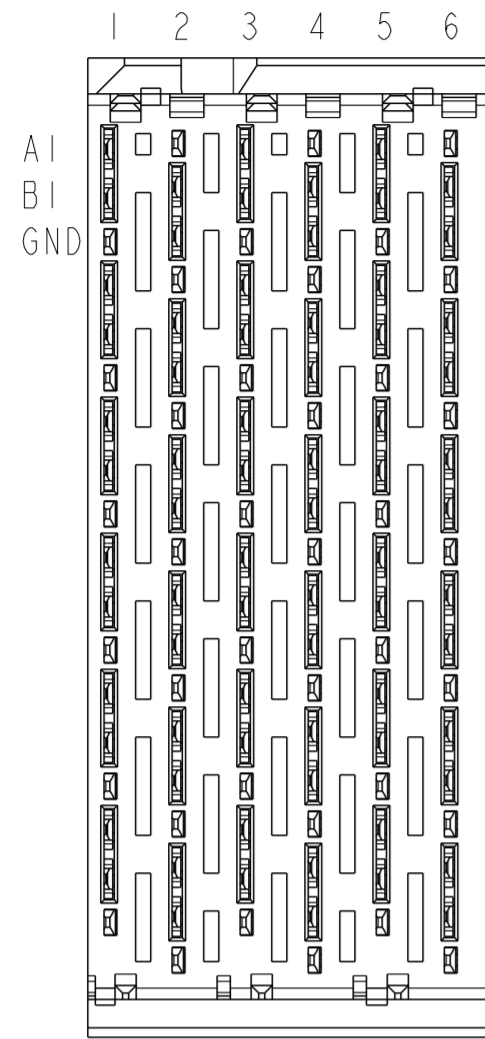

OPEN WALL MODULE

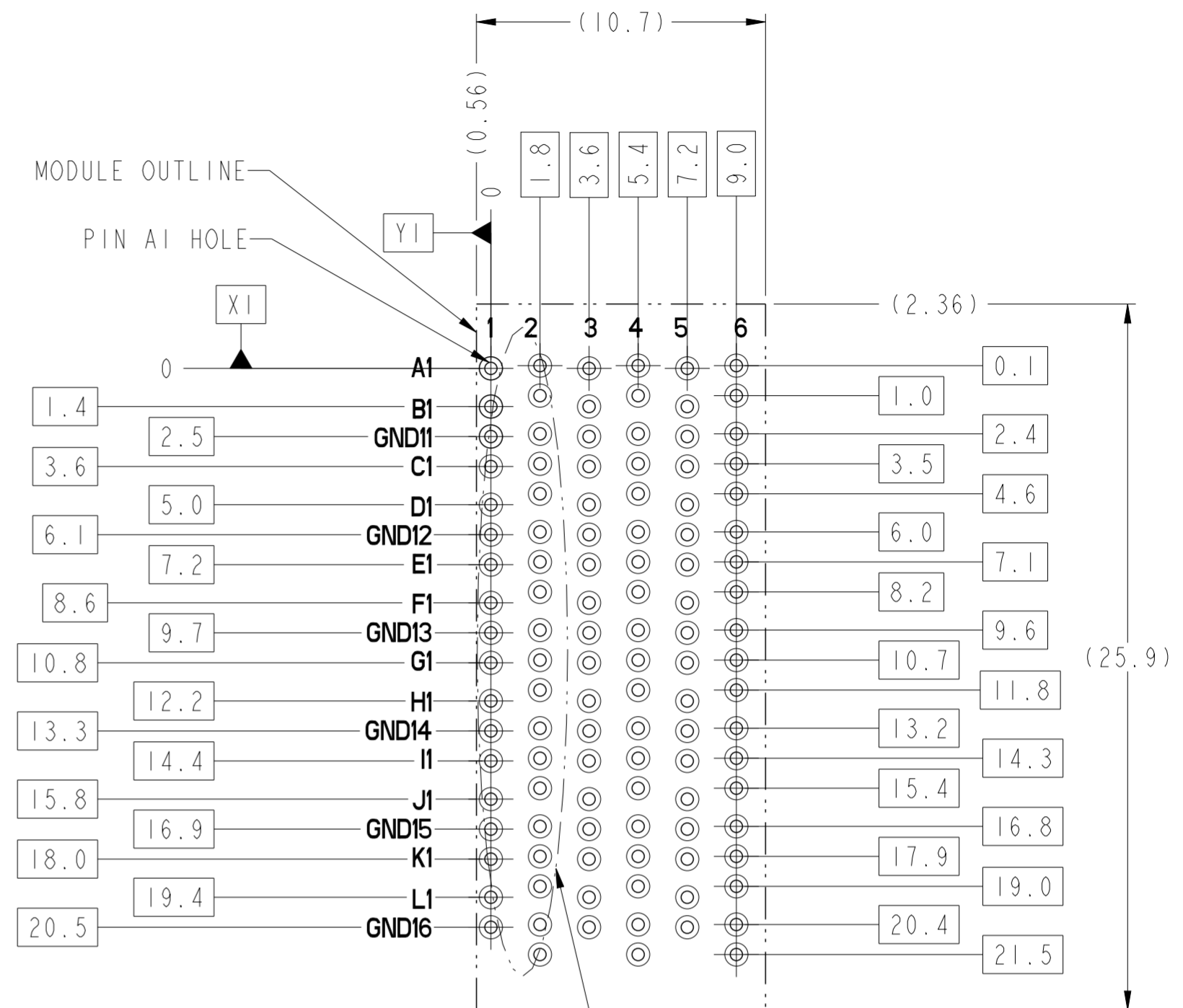
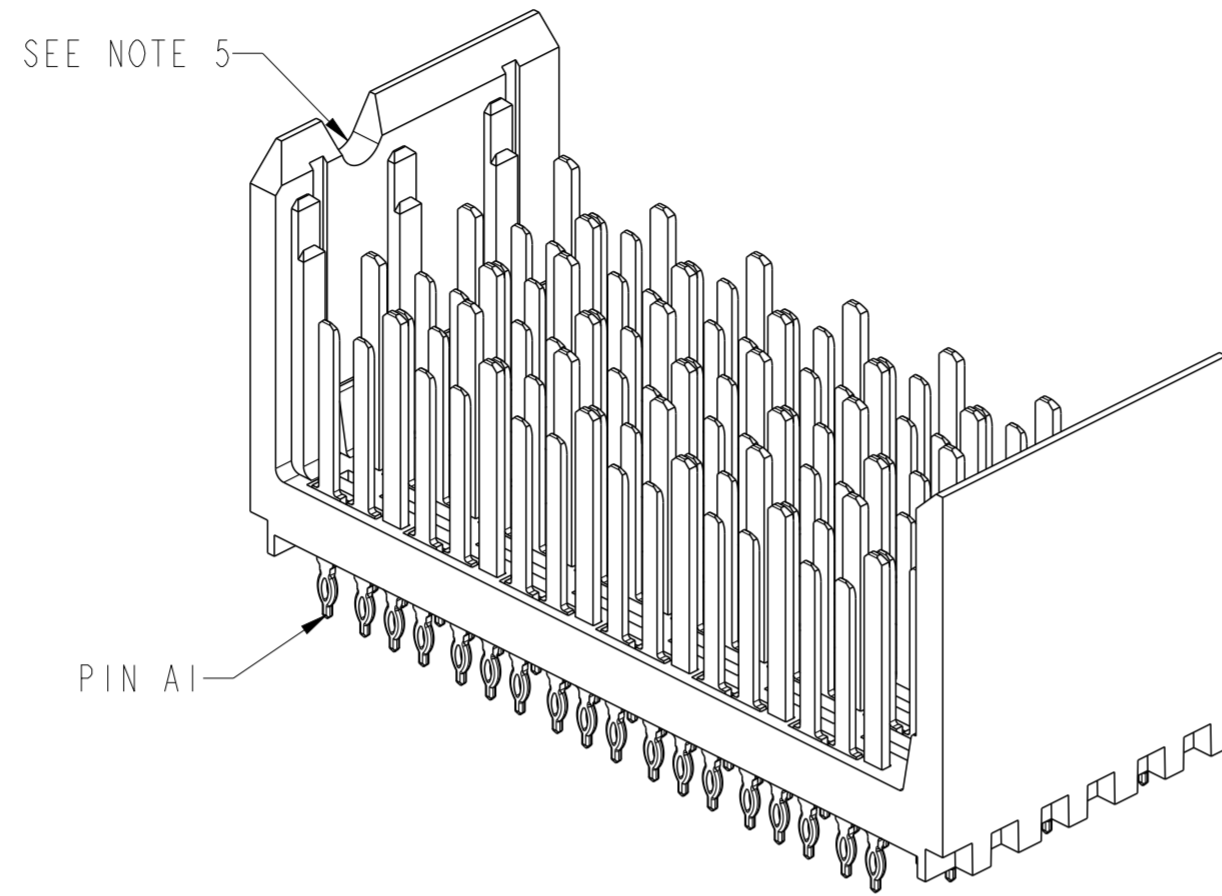

SEE DETAIL A ON SHEET 8 FOR PINOUT DETAILS

BP HOLE PATTERN COMPONENT SIDE
OPEN WALL MODULE BACKPLANE FOOTPRINT

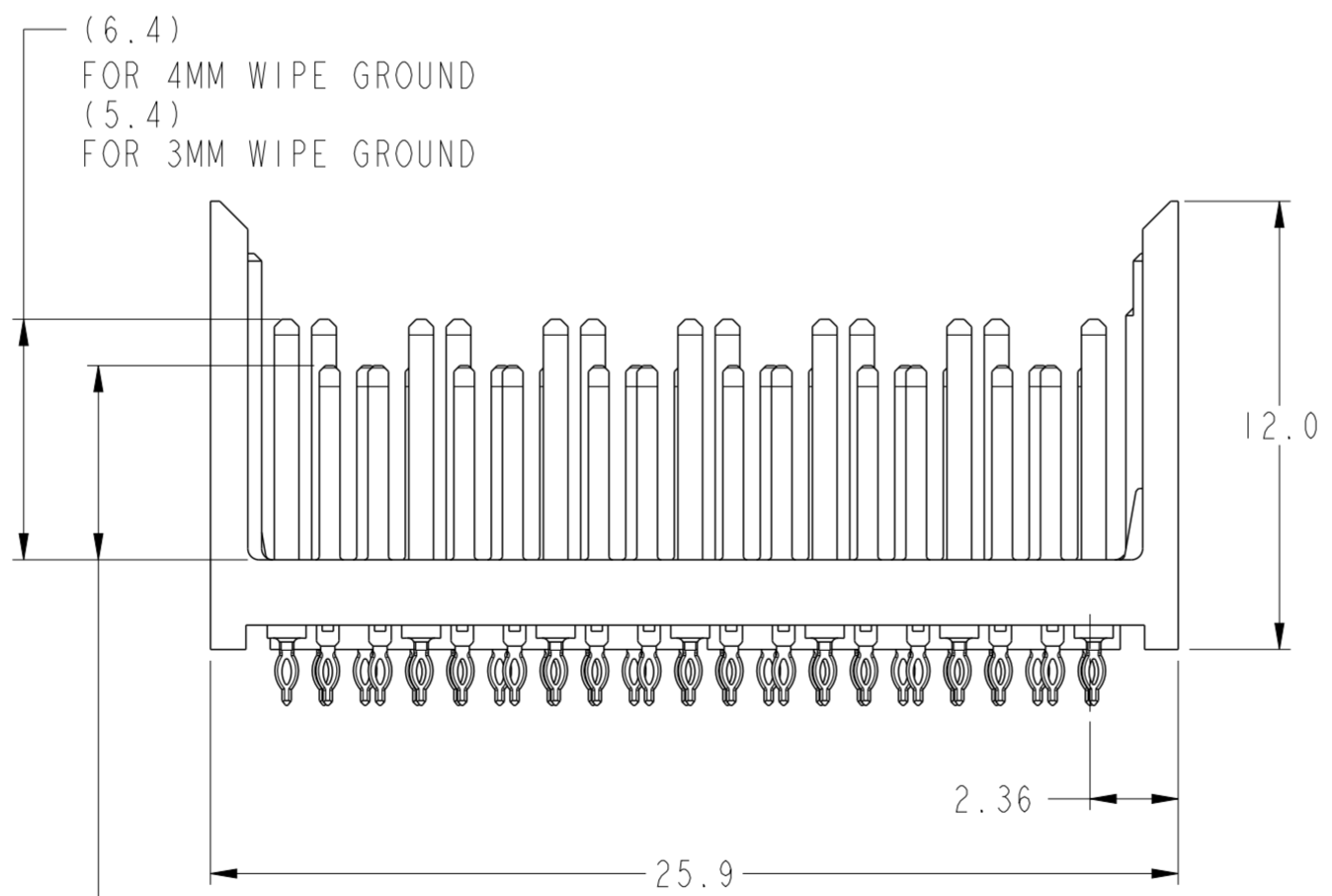
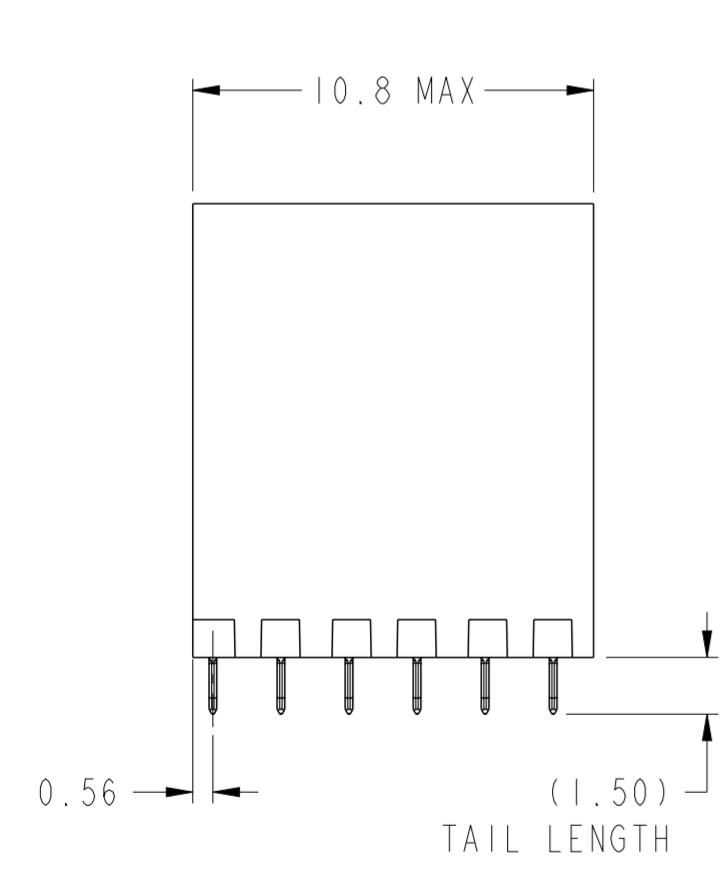

(5.2) FOR 3MM WIPE SIGNAL
(4.2) FOR 2MM WIPE SIGNAL



Copyright FCI.

spec ref	-	dr	Mary Glass	2012/02/09	projection	MM	size	A2	scale	5:1	
tolerance std	ASME Y14.5	eng	Sandar Soe	2013/03/20			ecn no	ELX-8-14229-1	rel level	Released	
TOLERANCES UNLESS OTHERWISE SPECIFIED		chr	-	product family							XCEDE HD
surface	linear	0.X	±0.3		VERTICAL HEADER ASSEMBLY XCEDE HD 6 PAIR, 6 COLUMN	www.fci.com	cat. no.	Product - Customer Drw	sheet 2 of 8	title 10119130	rev B
	angular	0°	±2°							dwg no	rel level

PDS: Rev :B

STATUS:Released

Printed: Apr 10, 2013

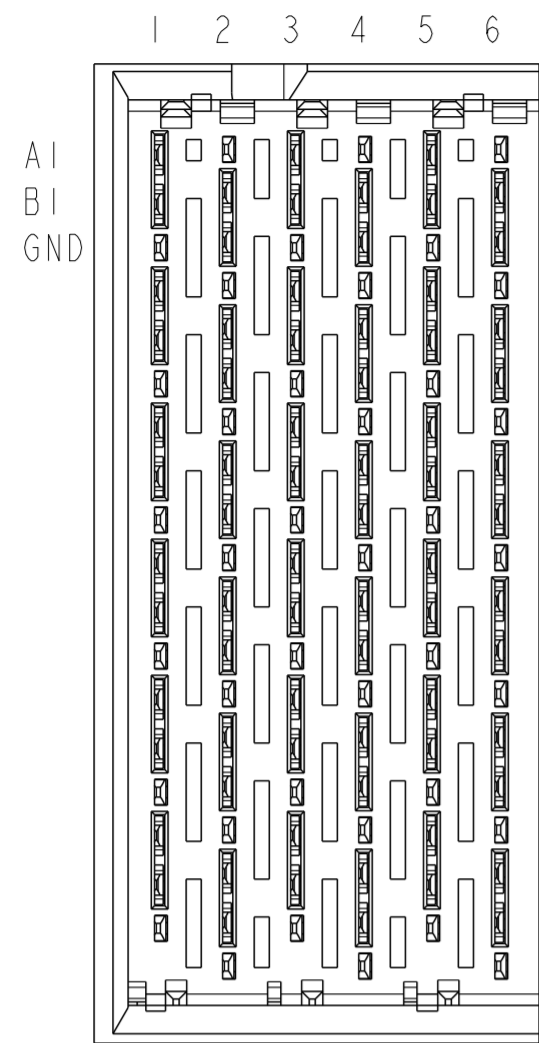

LEFT WALL MODULE

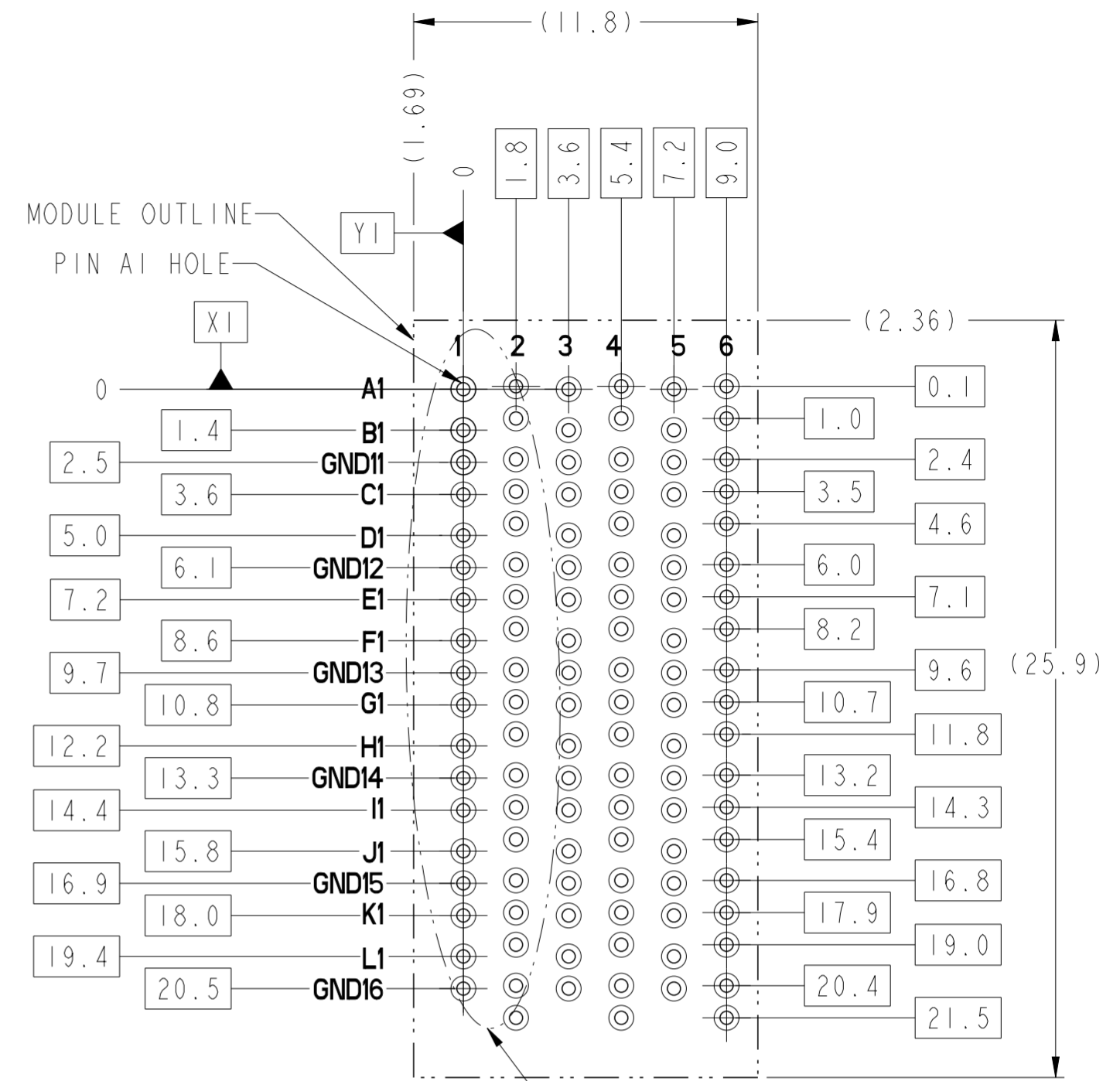
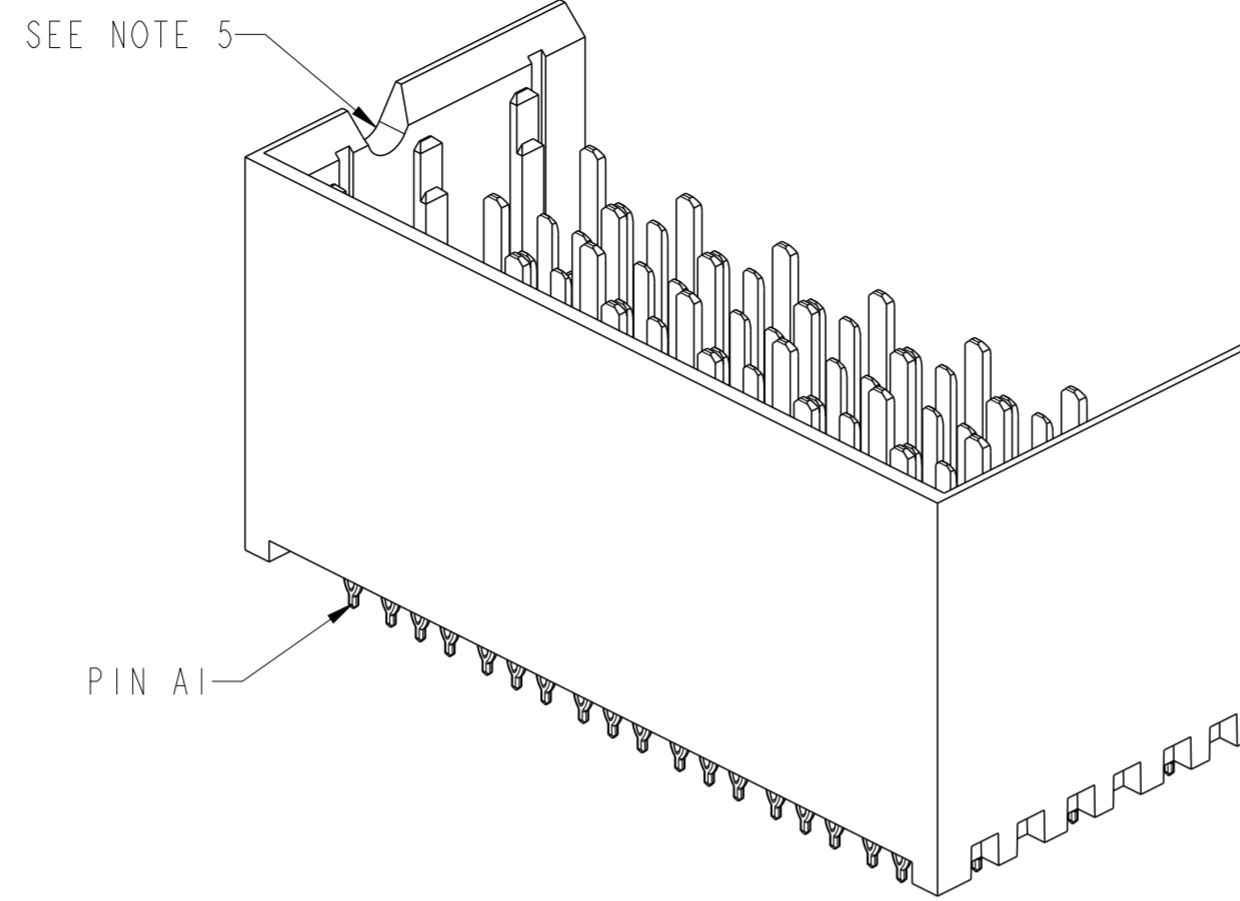

BP HOLE PATTERN COMPONENT SIDE
LEFT WALL MODULE BACKPLANE FOOTPRINT

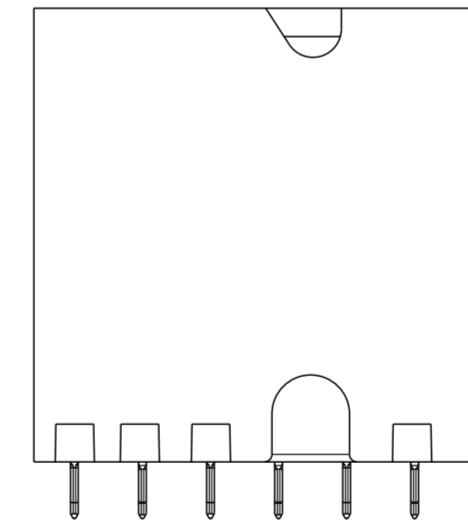
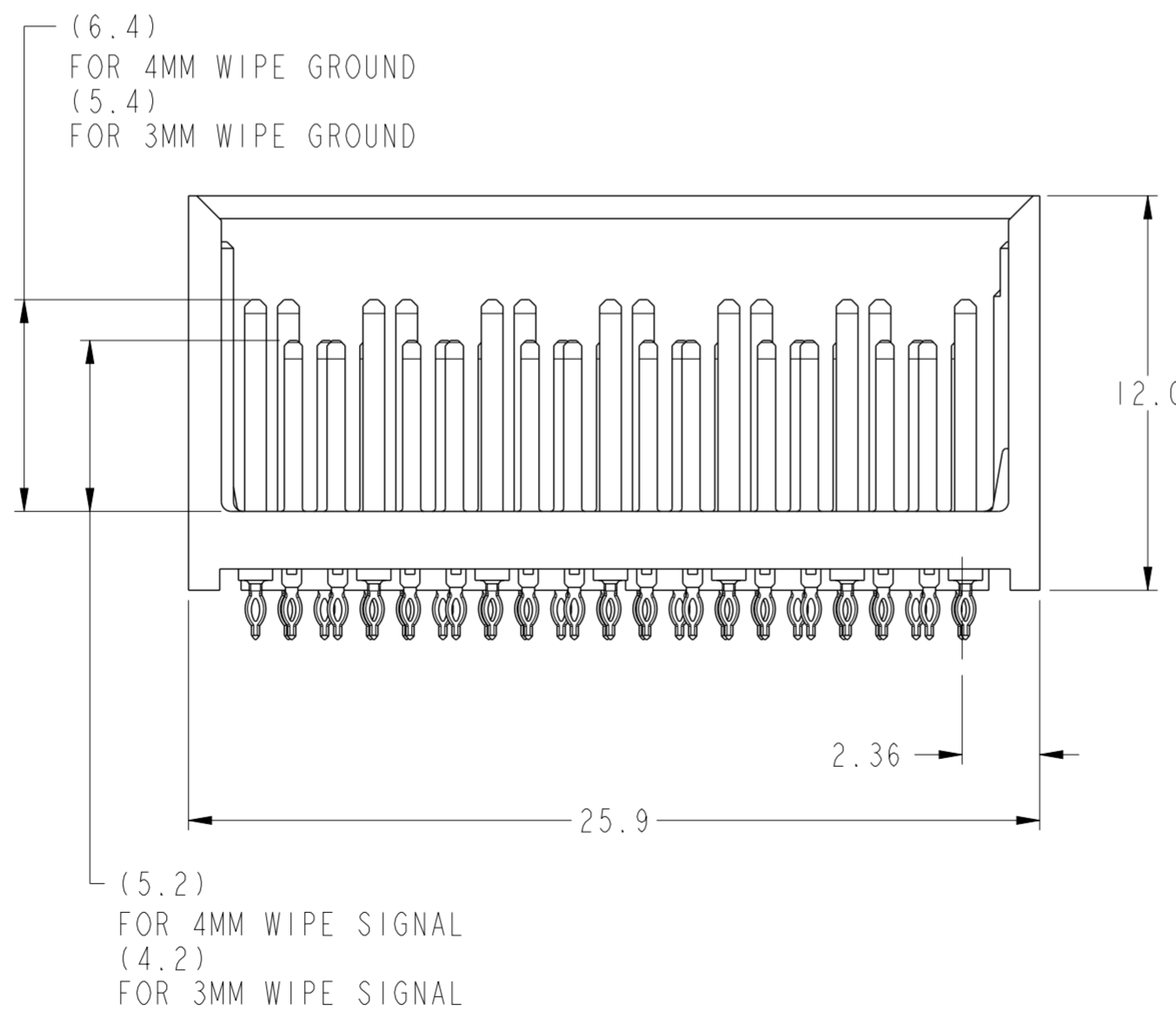
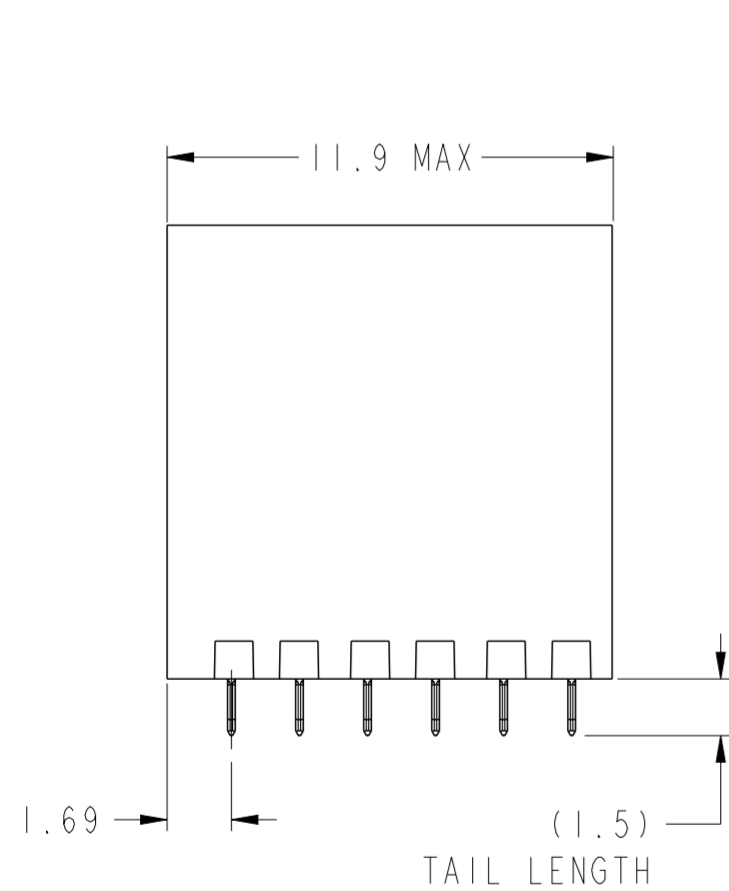

spec ref	-	dr	Mary Glass	2012/02/09	projection	MM	size	A2	scale	5:1												
tolerance std	ASME Y14.5	eng	Sandar Soe	2013/03/20			ecn no	ELX-8-14229-1														
TOLERANCES UNLESS OTHERWISE SPECIFIED		chr	-	rel level			Released															
surface	<table border="1"> <tr> <td>linear</td> <td>0.X</td> <td>±0.3</td> </tr> <tr> <td></td> <td>0.XX</td> <td>±0.10</td> </tr> <tr> <td></td> <td>0.XXX</td> <td>±0.05</td> </tr> <tr> <td>angular</td> <td>0°</td> <td>±2°</td> </tr> </table>	linear	0.X	±0.3		0.XX	±0.10		0.XXX	±0.05	angular	0°	±2°	appr	Chen-Hong Tan	2013/04/09	product family	XCEDE HD	rel level	Released	rev	B
linear	0.X	±0.3																				
	0.XX	±0.10																				
	0.XXX	±0.05																				
angular	0°	±2°																				
www.fci.com				VERTICAL HEADER ASSEMBLY XCEDE HD 6 PAIR, 6 COLUMN		cat. no.	10119130		sheet 3 of 8													

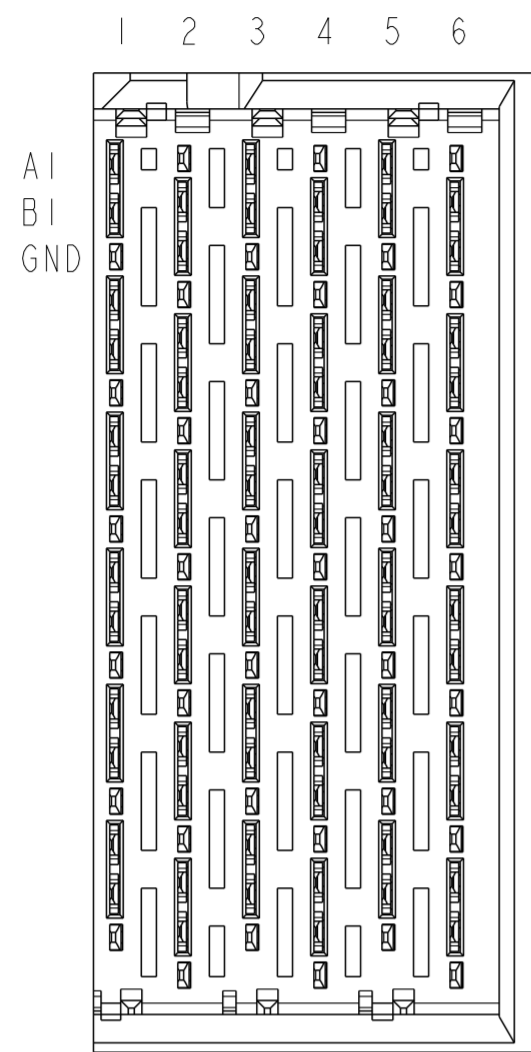

RIGHT WALL MODULE

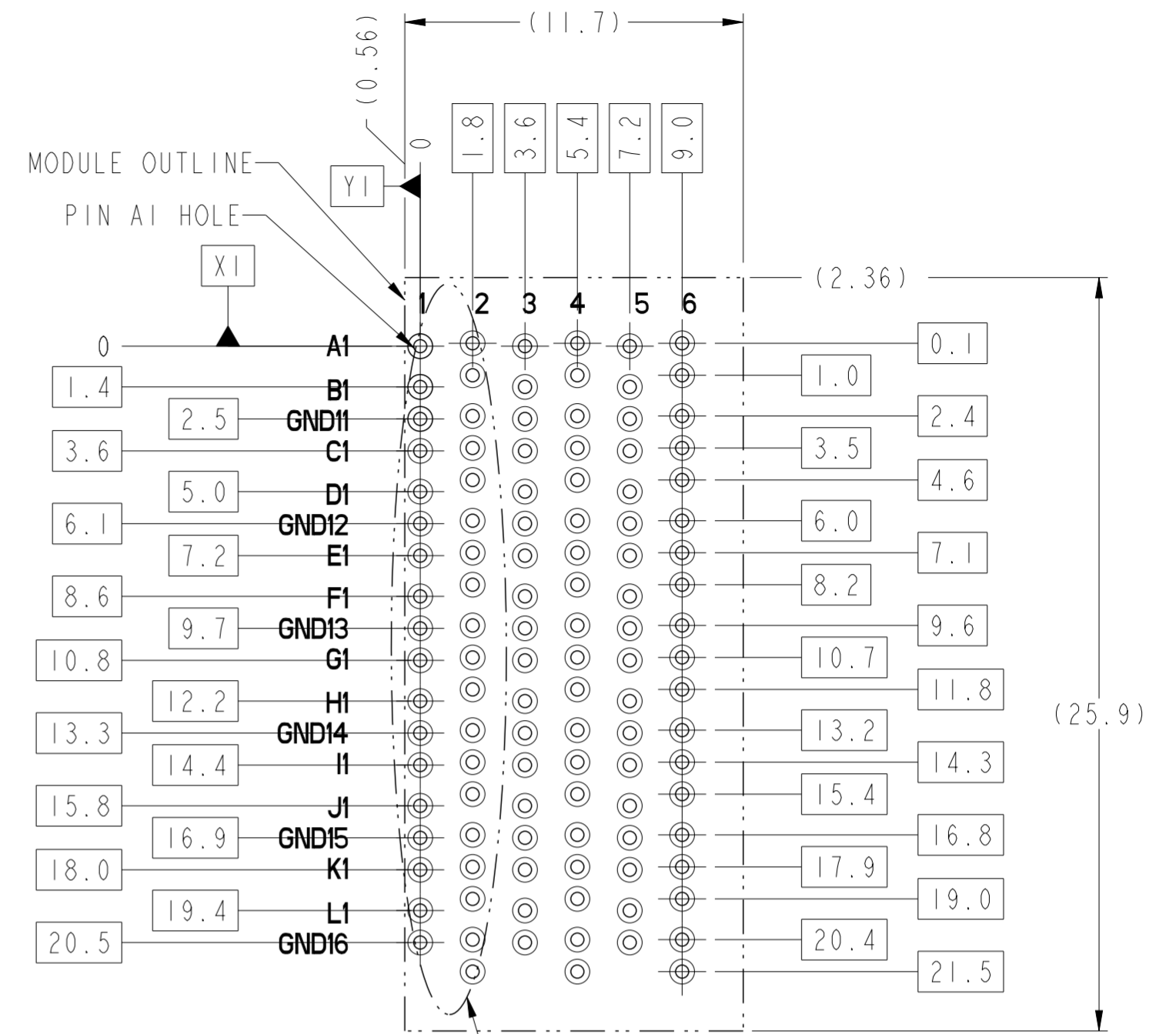
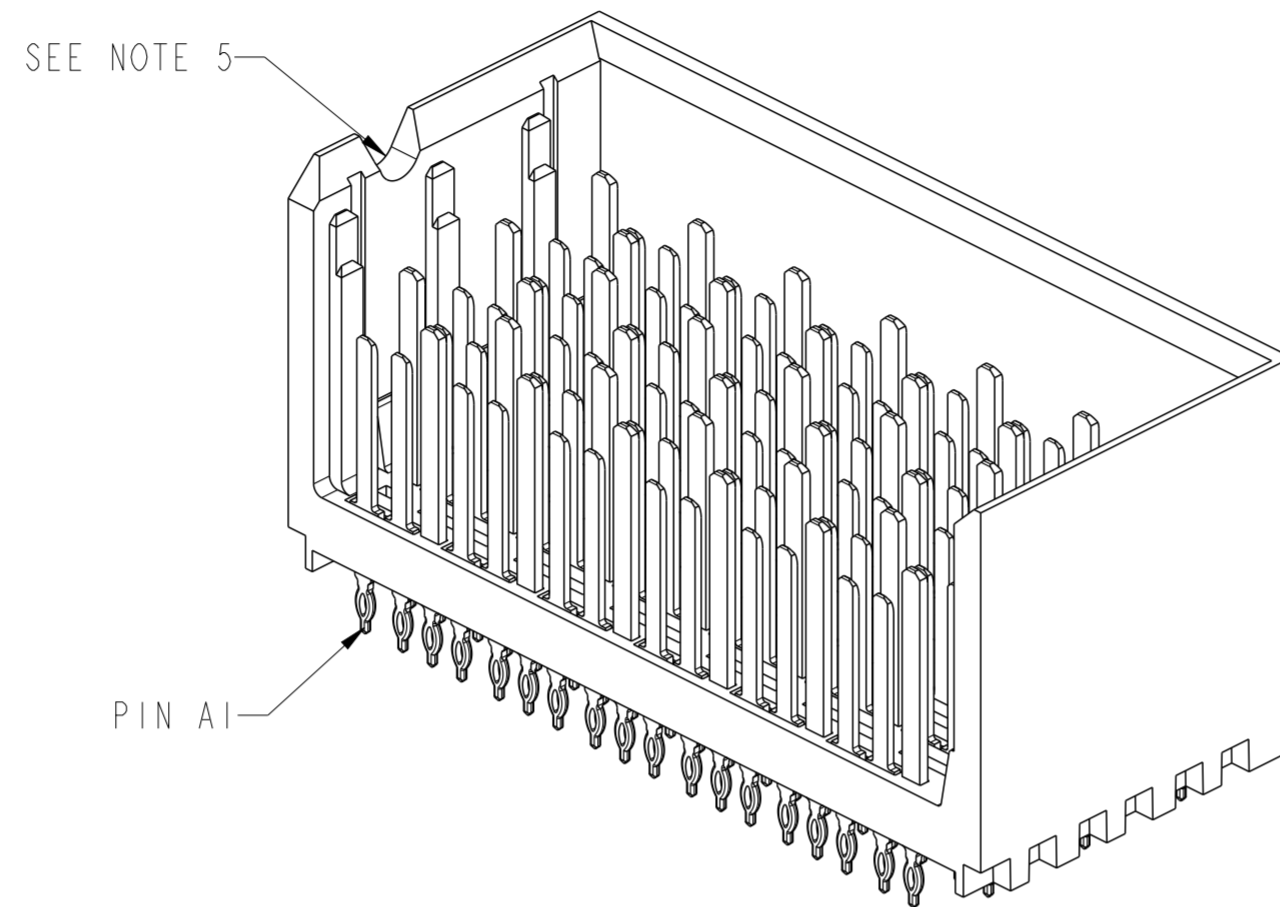

BP HOLE PATTERN COMPONENT SIDE
RIGHT WALL MODULE BACKPLANE FOOTPRINT

SEE DETAIL A
ON SHEET 8 FOR PINOUT DETAILS

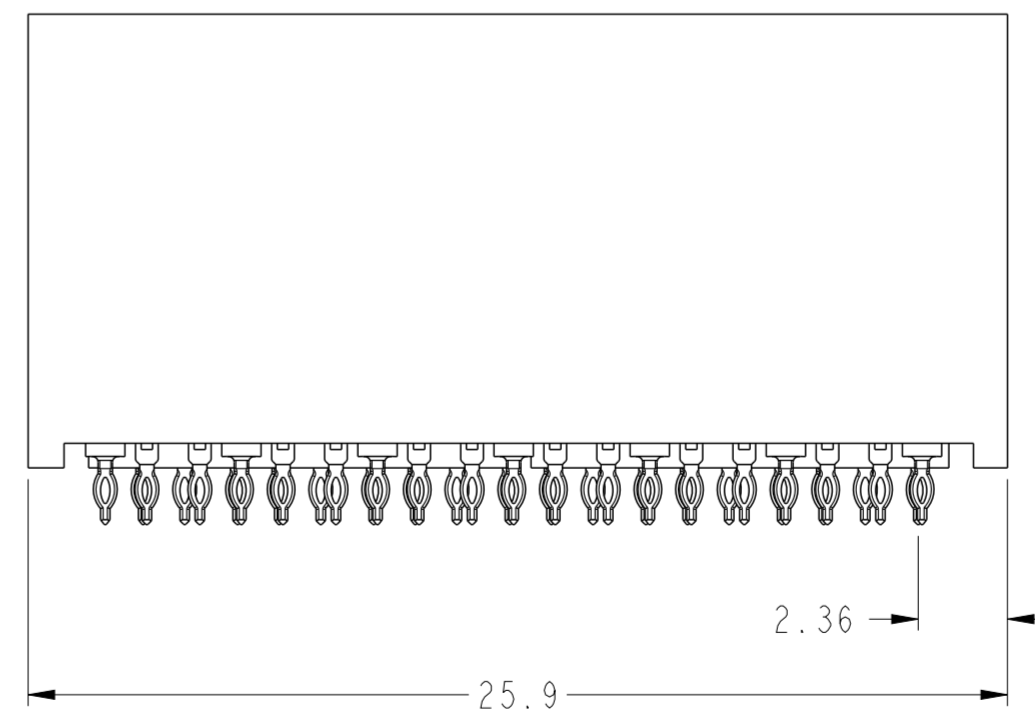
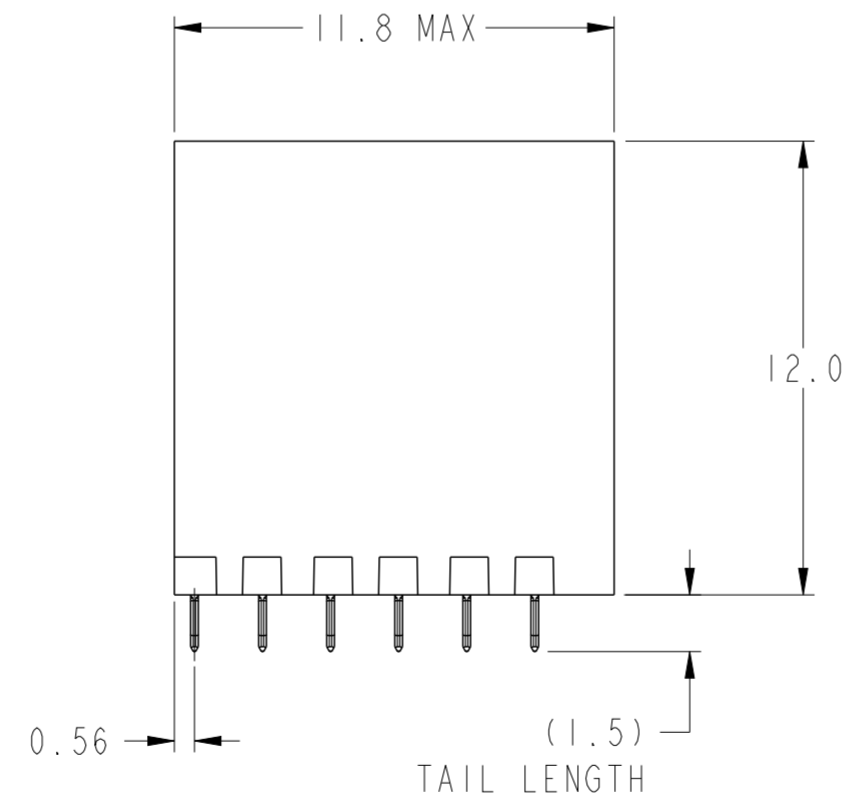
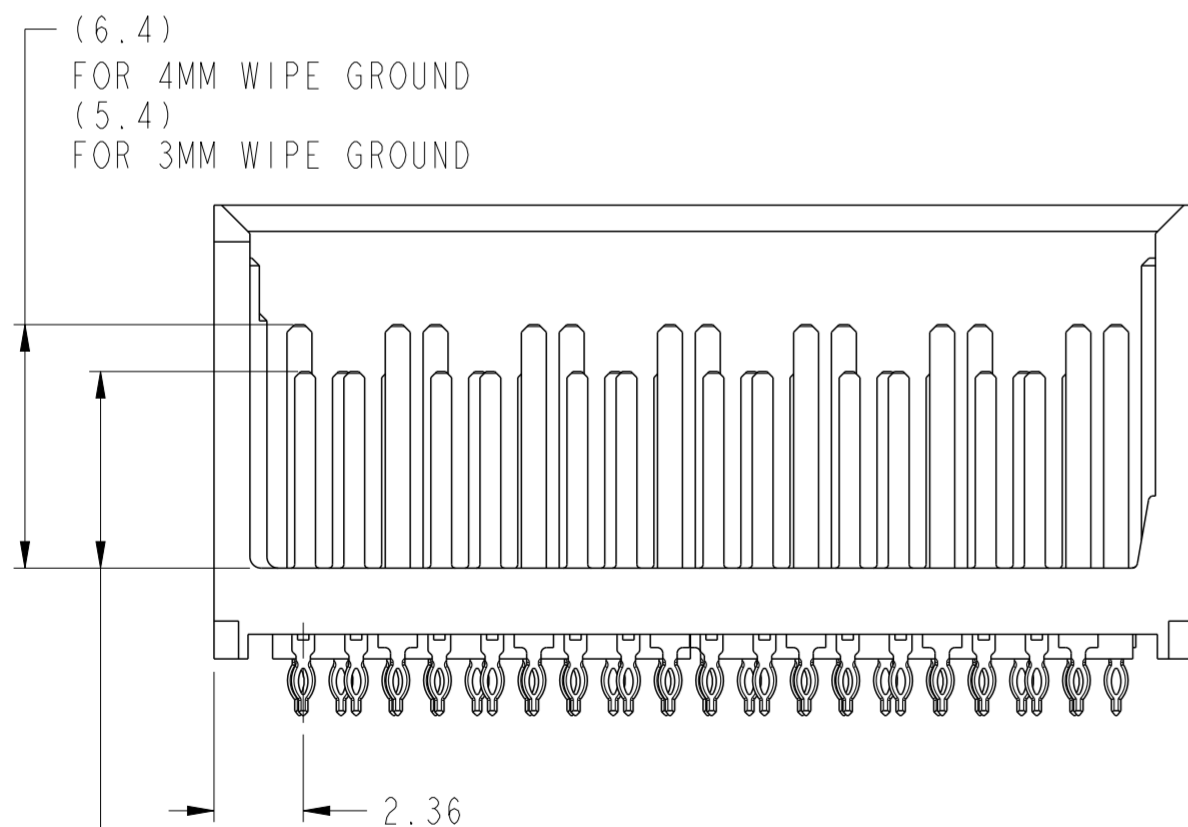

(5.2)
FOR 4MM WIPE SIGNAL
(4.2)
FOR 3MM WIPE SIGNAL



Copyright FCI.

spec ref	-	dr	Mary Glass	2012/02/09	projection	MM	size	A2	scale	5:1
tolerance std	ASME Y14.5	eng	Sandar Soe	2013/03/20			ecn no	ELX-8-14229-1		
TOLERANCES UNLESS OTHERWISE SPECIFIED		chr	-	appr			Chen-Hong Tan	2013/04/09	product family	XCEDE HD
surface	linear	0.X	±0.3		VERTICAL HEADER ASSEMBLY XCEDE HD 6 PAIR, 6 COLUMN	www.fci.com	cat. no.	-	Product - Customer Drw	sheet 4 of 8
	0.XX	±0.10	dwg no				10119130	rev	B	
	0.XXX	±0.05	angular				0°	±2°		

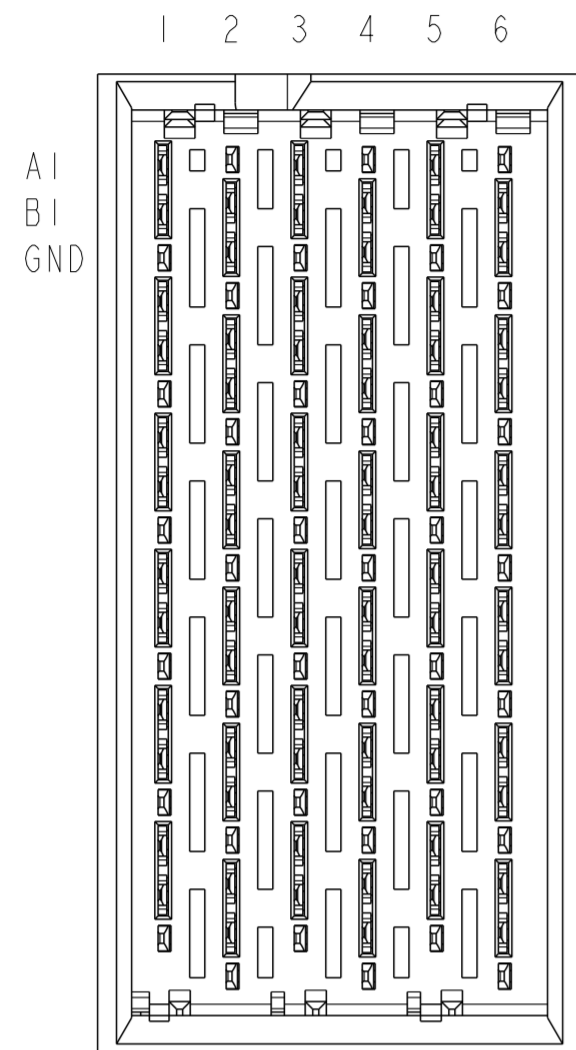

FOUR WALL MODULE

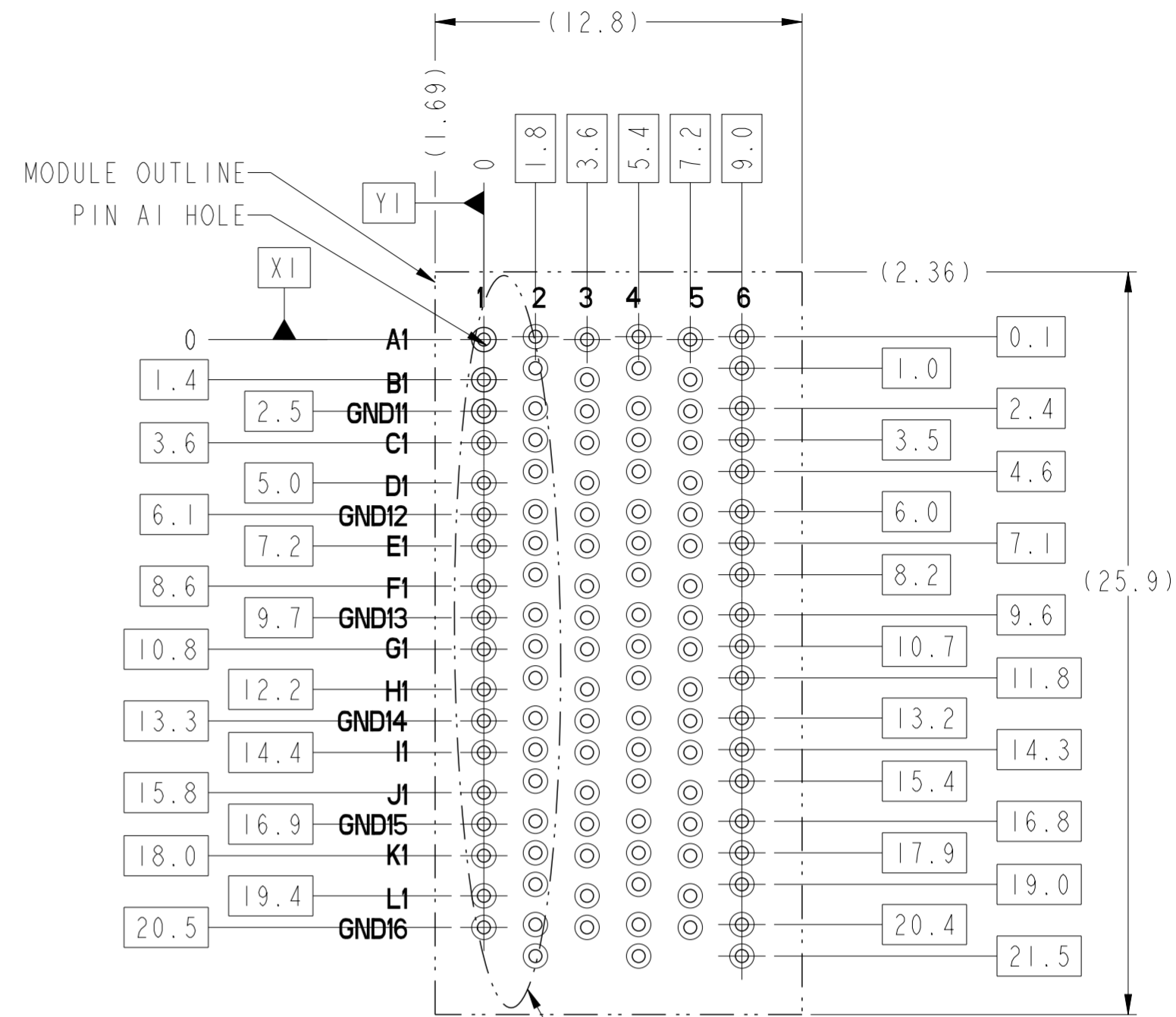
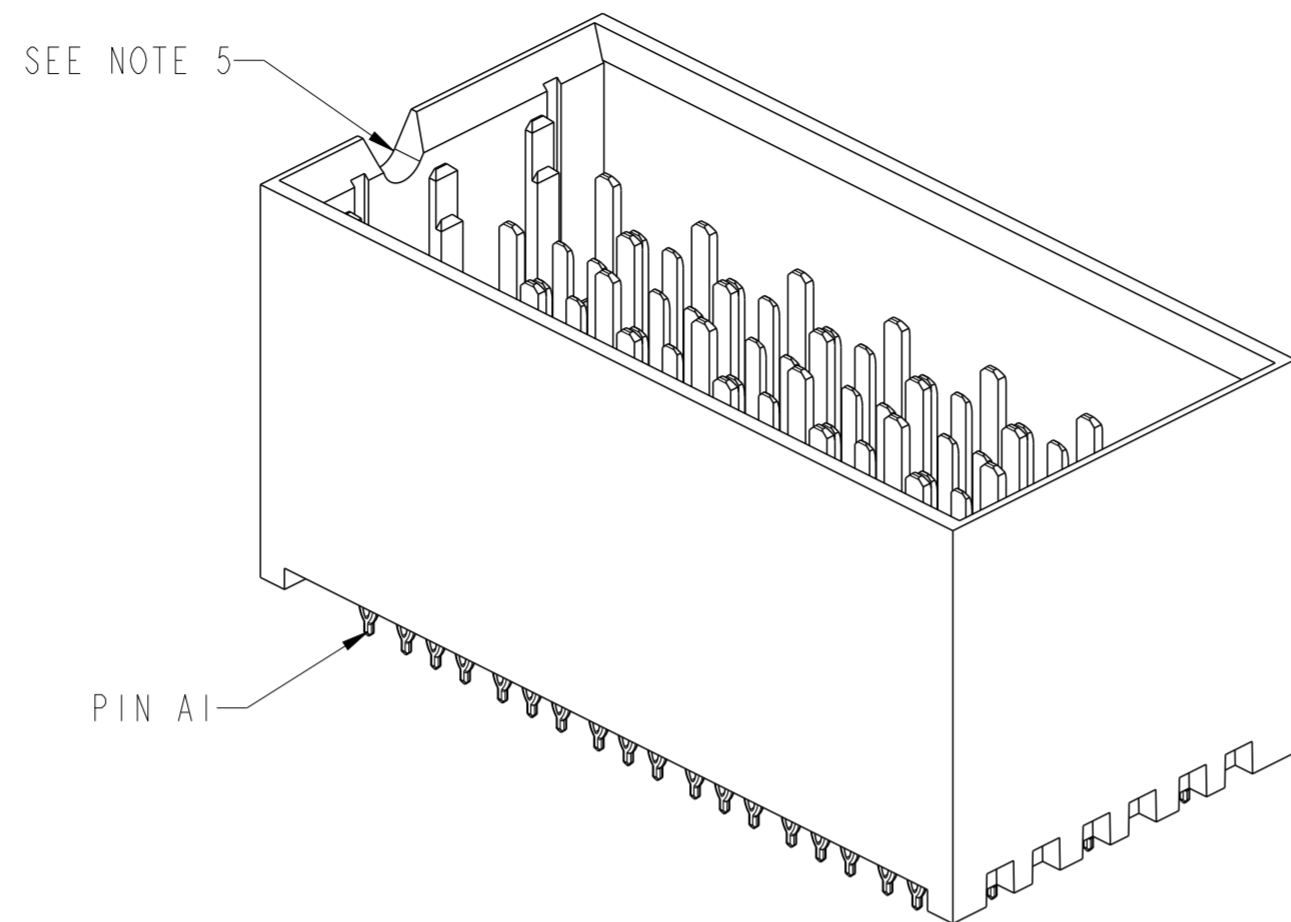

BP HOLE PATTERN COMPONENT SIDE

FOUR WALL MODULE BACKPLANE FOOTPRINT

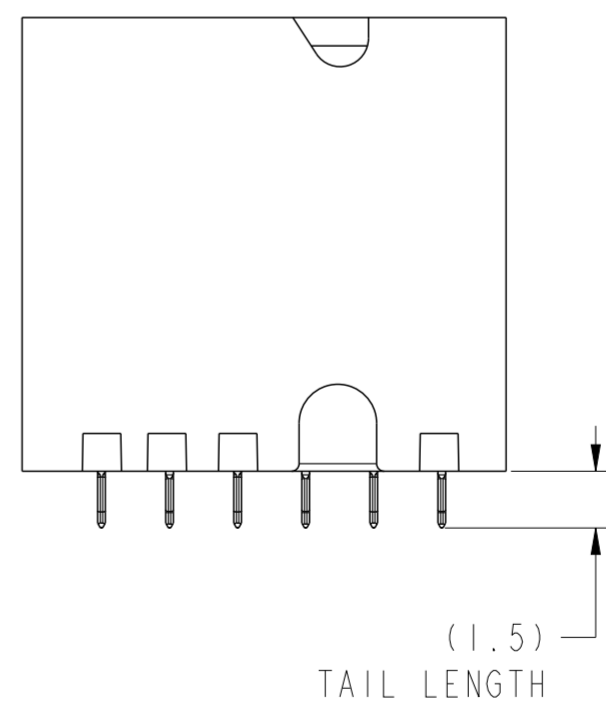
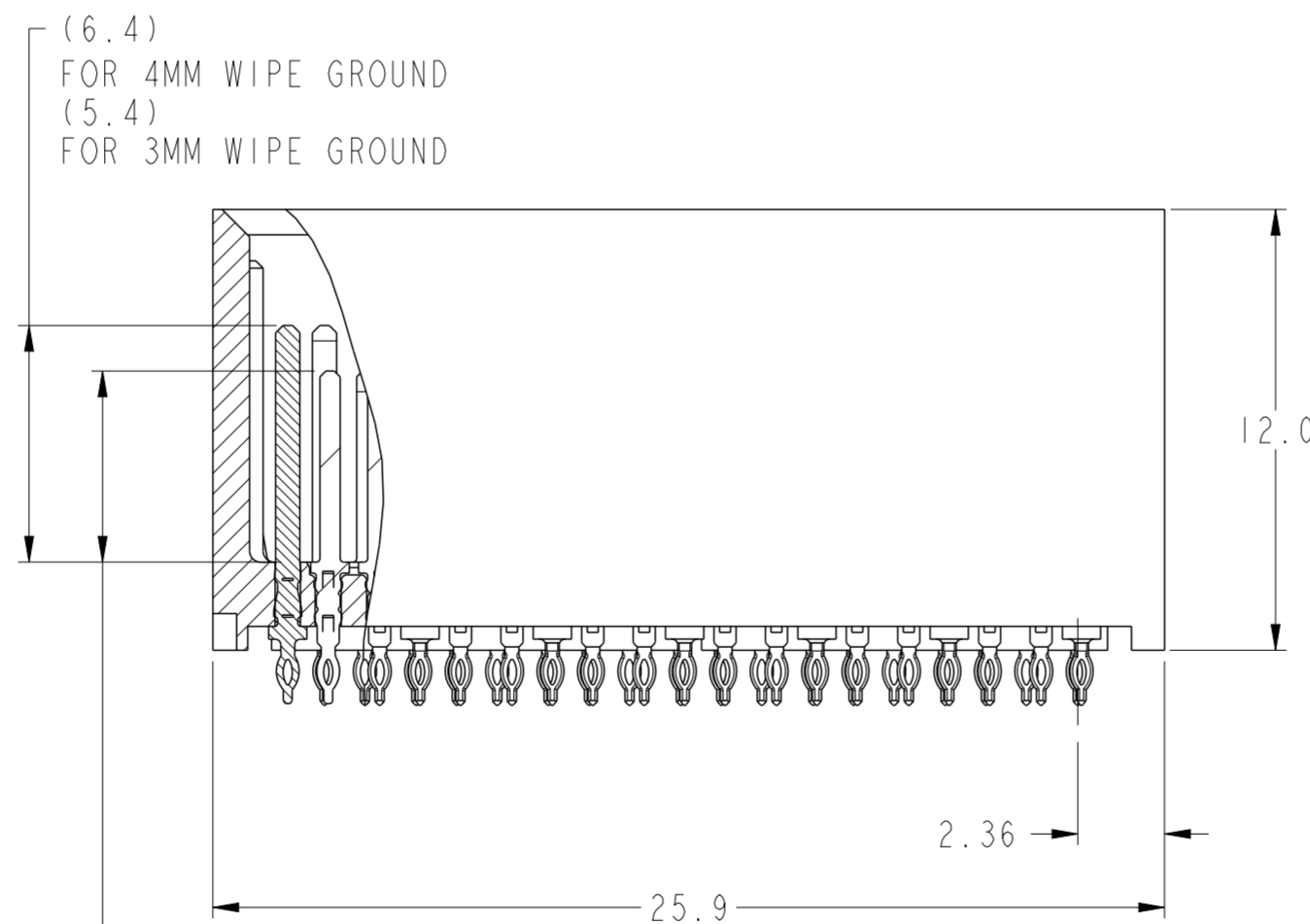
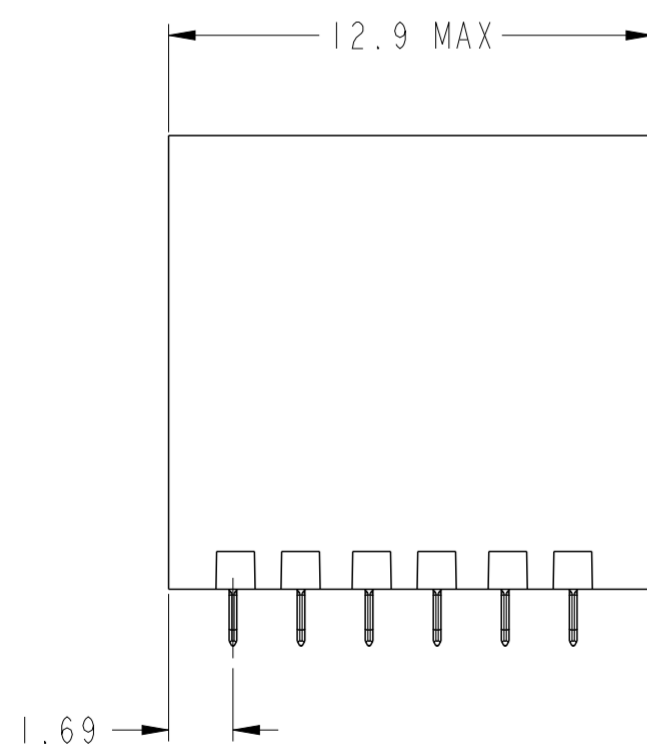

(5.2)
FOR 4MM WIPE SIGNAL
(4.2)
FOR 3MM WIPE SIGNAL

spec ref	-	dr	Mary Glass	2012/02/09	projection	MM	size	A2	scale	5:1	
tolerance std	ASME Y14.5	eng	Sandar Soe	2013/03/20			ecn no	ELX-8-1429-1			
TOLERANCES UNLESS OTHERWISE SPECIFIED		chr	-	appr			Chen-Hong Tan	2013/04/09	product family	XCEDE HD	rel level
surface	linear	0.X	±0.3		VERTICAL HEADER ASSEMBLY XCEDE HD 6 PAIR, 6 COLUMN		dwg no	10119130			
		0.XX	±0.10		www.fci.com	cat. no.	-	Product - Customer Drw	sheet 5 of 8		
	angular	0°	±2°		PDS: Rev :B		STATUS:Released		Printed: Apr 10, 2013		

Copyright FCI.

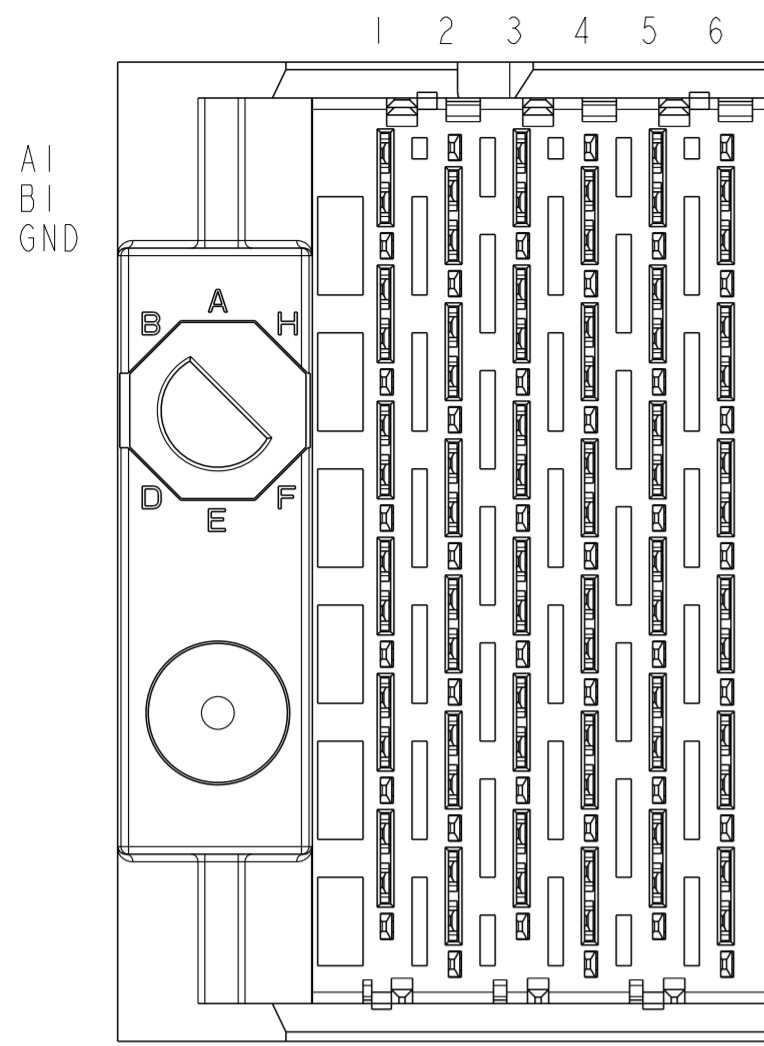

LEFT POLARIZING / GUIDE MODULE

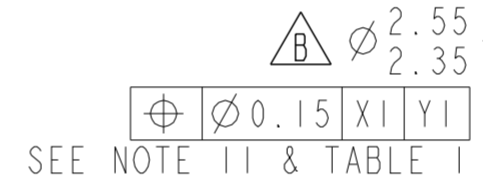
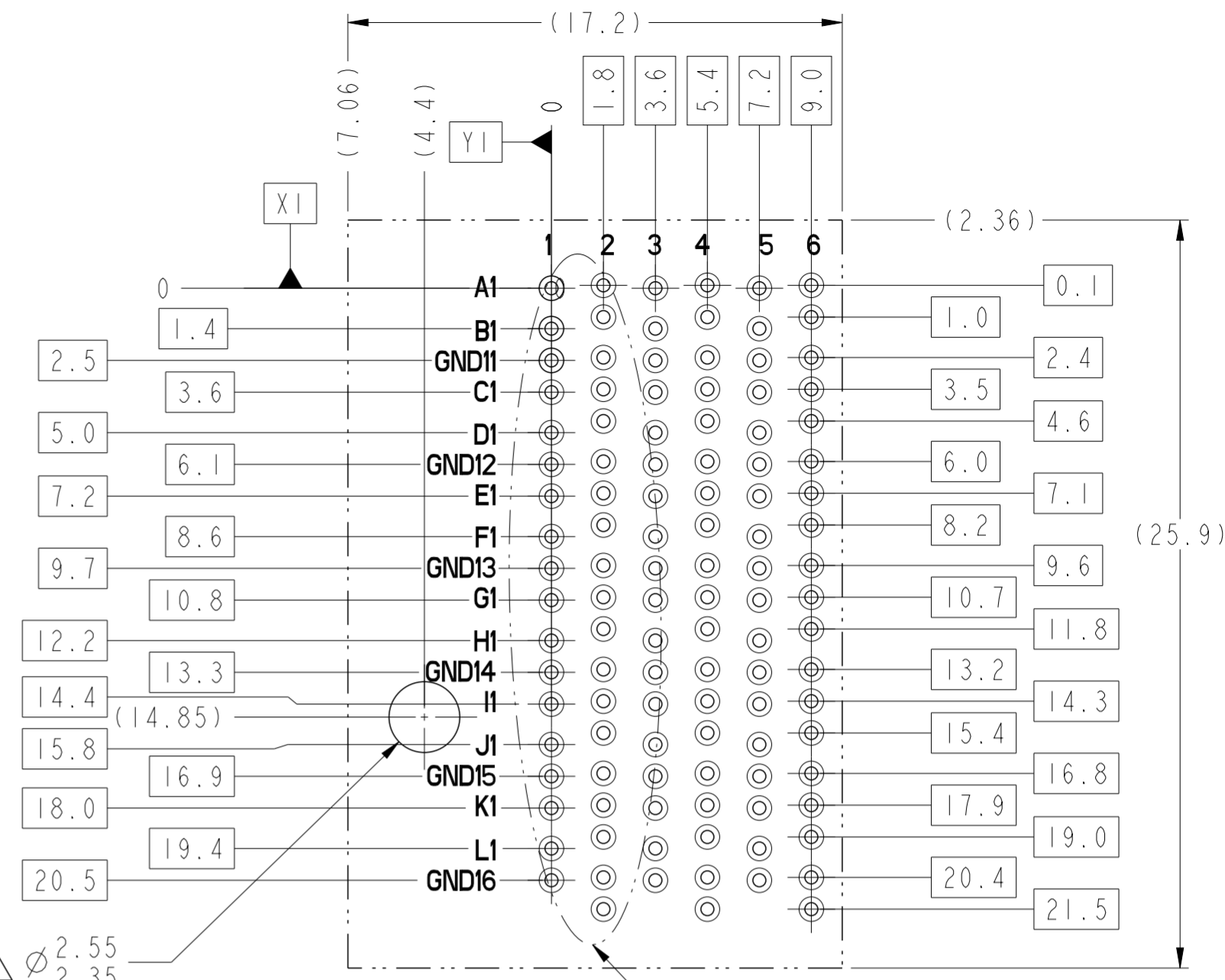
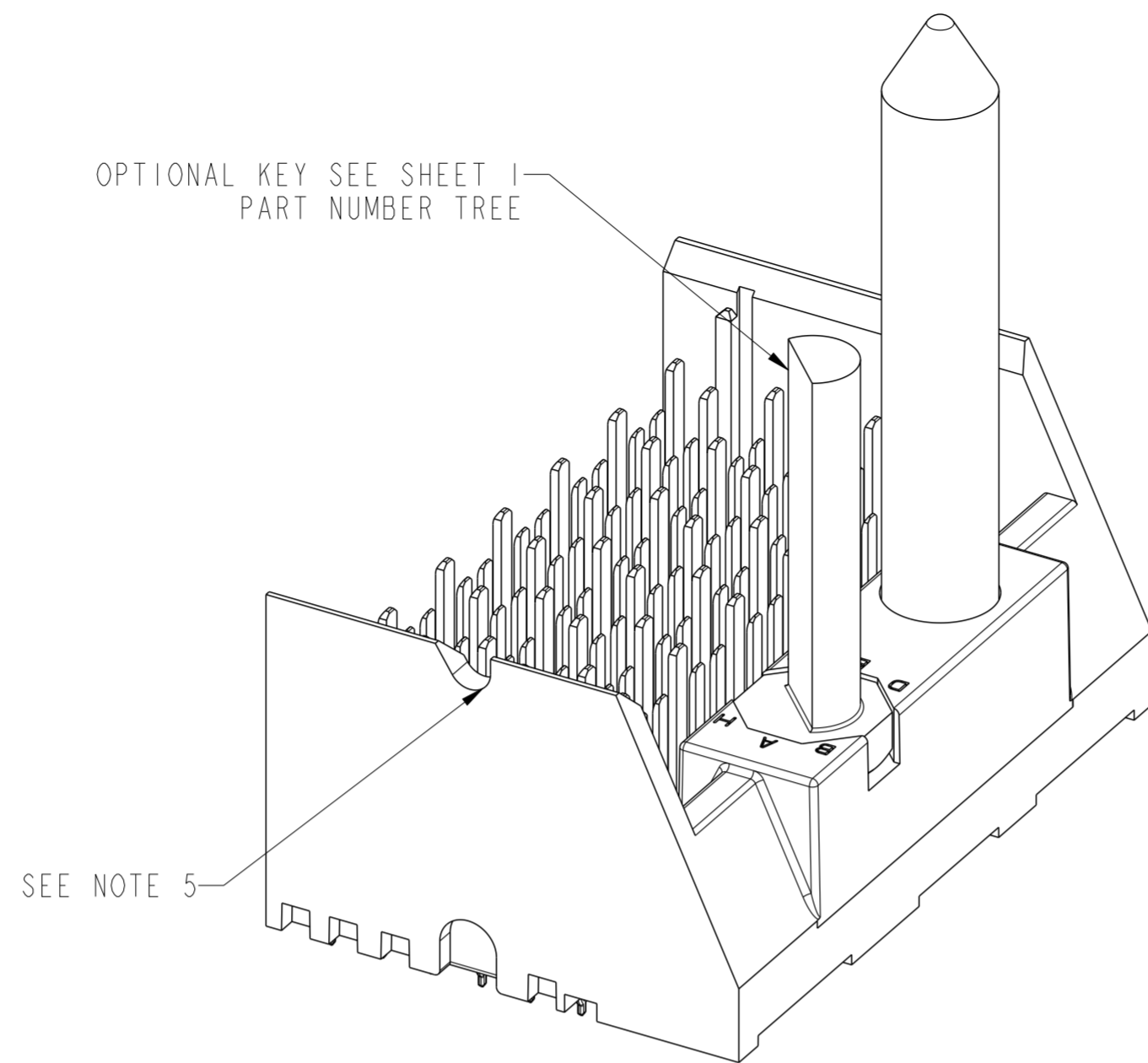

SEE DETAIL A ON SHEET 8 FOR PINOUT DETAILS

BP HOLE PATTERN COMPONENT SIDE
LEFT POLARIZING GUIDE MODULE
BACKPLANE FOOTPRINT

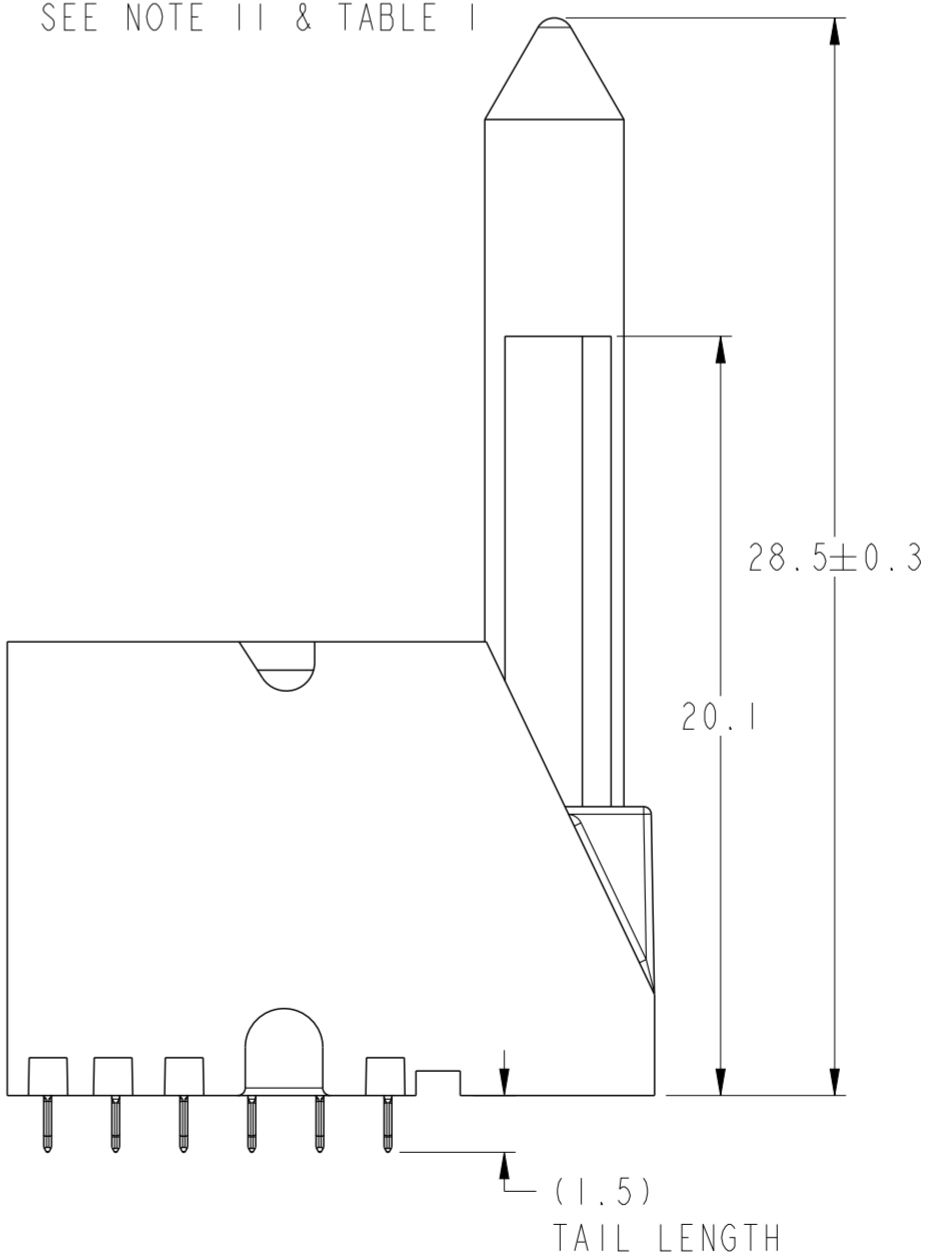
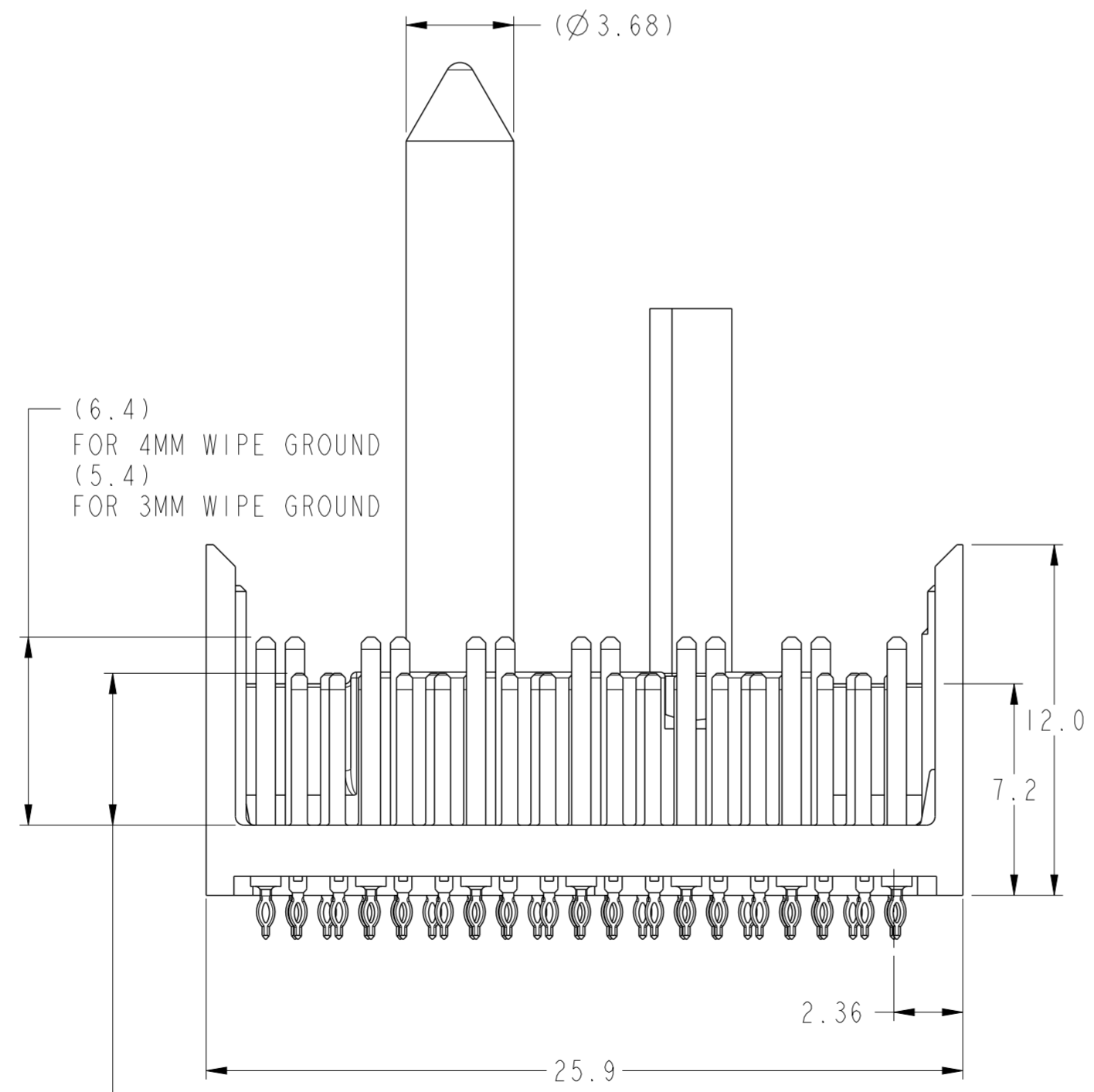
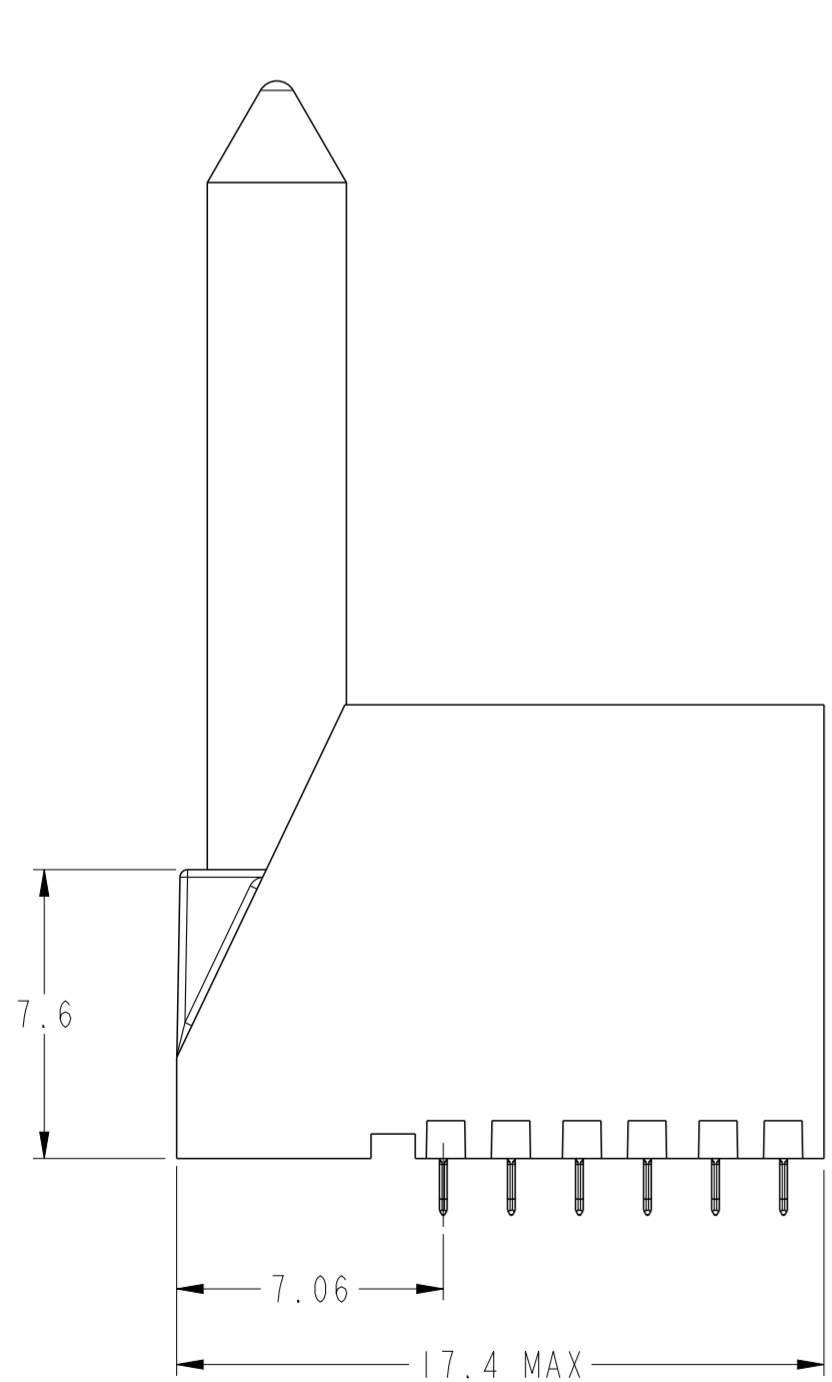

(5.2) FOR 4MM WIPE SIGNAL
(4.2) FOR 3MM WIPE SIGNAL

spec ref	-	dr	Mary Glass	2012/02/09	projection	MM	size	A2	scale	5:1
tolerance std	ASME Y14.5	eng	Sandar Soe	2013/03/20	chr	-	ecn no	ELX-8-14229-1	rel level	Released
surface	✓	appr	Chen-Hong Tan	2013/04/09	product family	XCEDE HD	rel level	Released	cat. no.	10119130
ASME Y14.5	linear	0.X	±0.3	0.XX	±0.10	0.XXX	±0.05	angular	0°	±2°

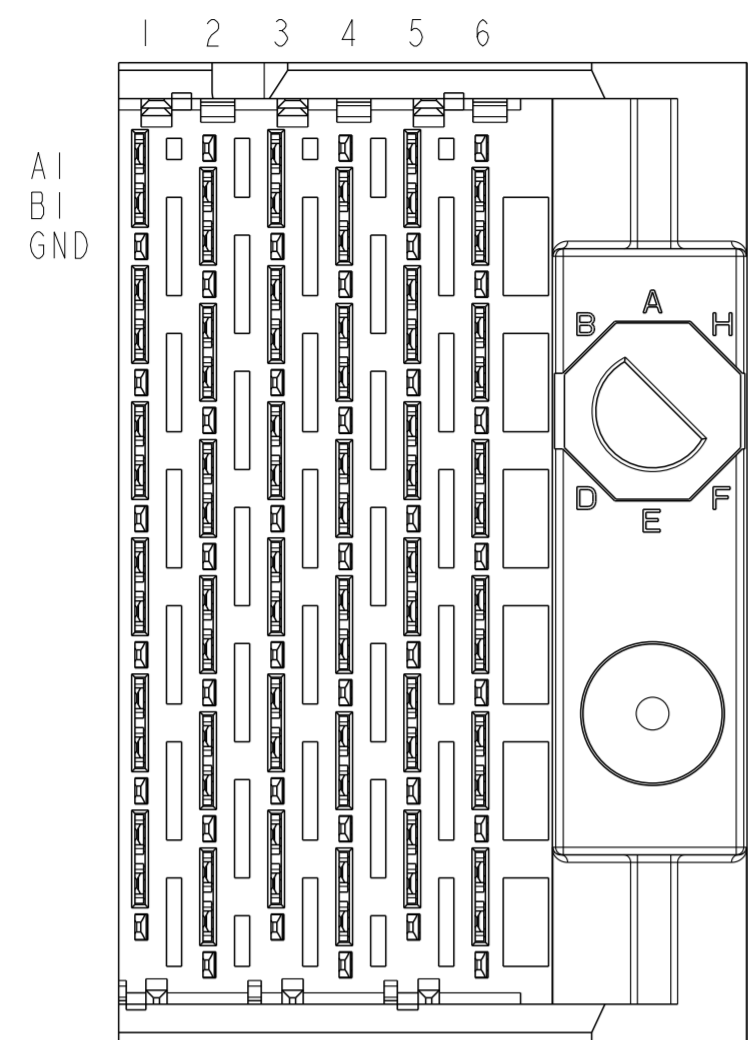

RIGHT POLARIZING GUIDE MODULE

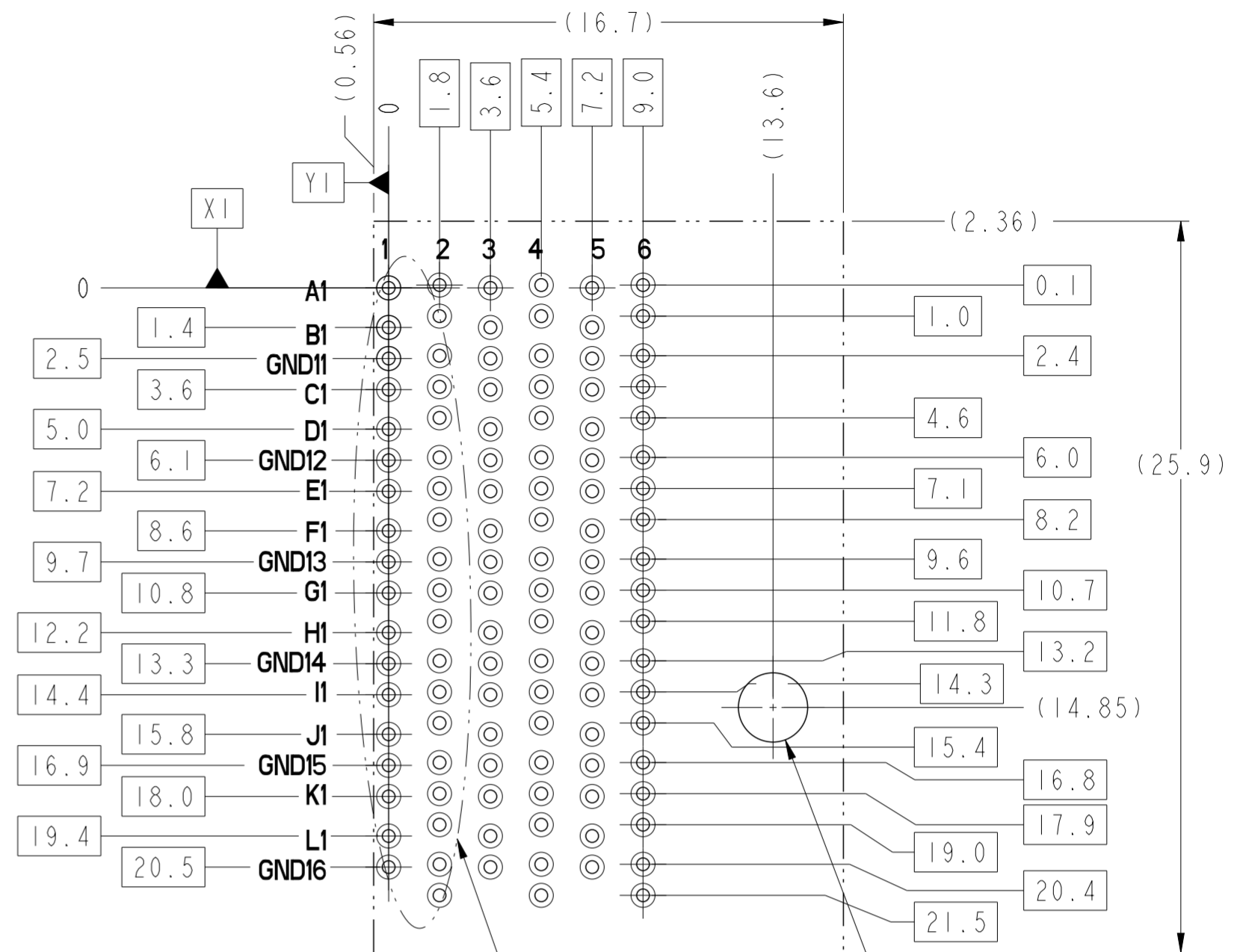
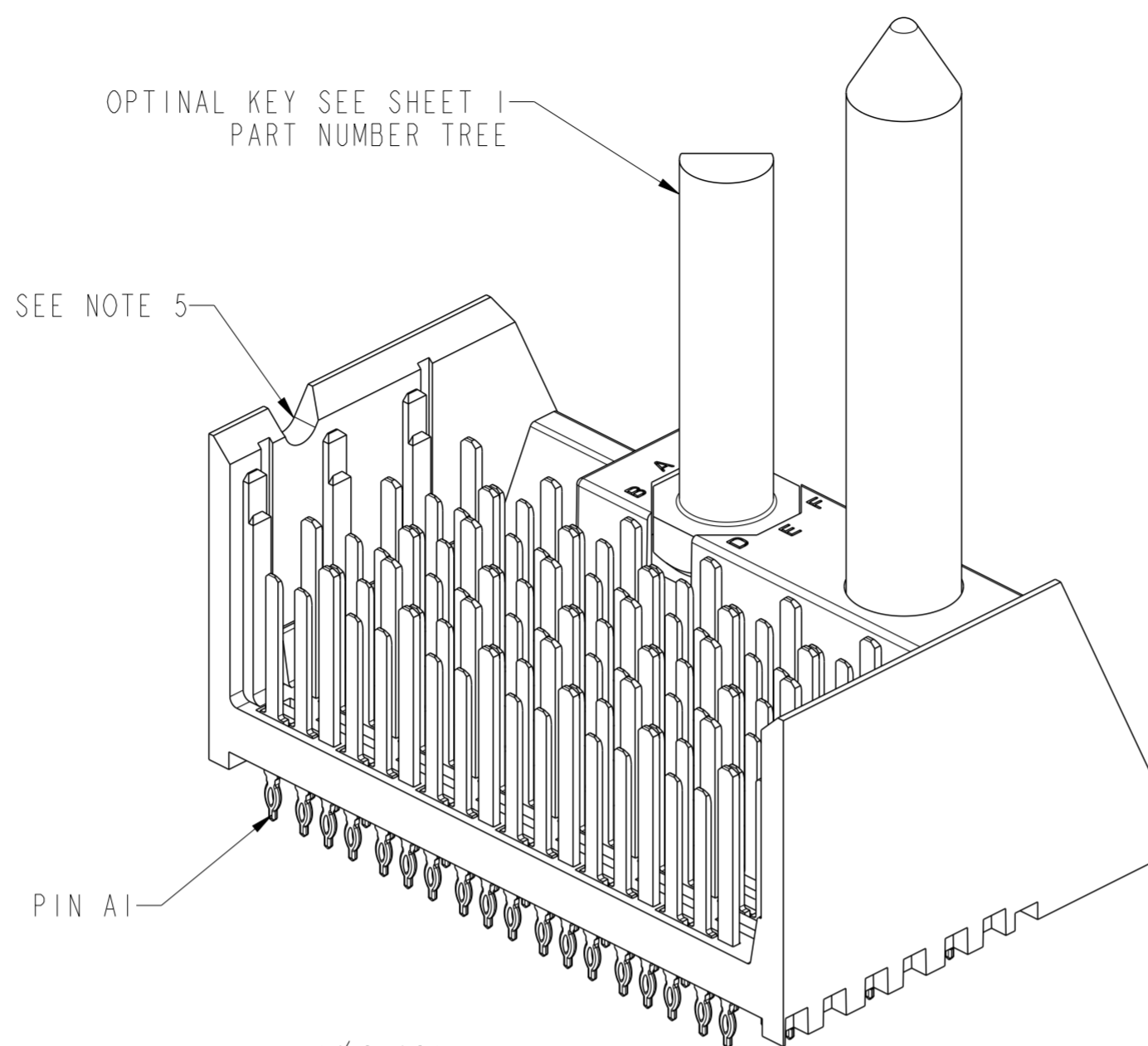

SEE DETAIL A ON SHEET 8 FOR PINOUT DETAILS

SEE NOTE 11 & TABLE 1

BP HOLE PATTERN COMPONENT SIDE
**RIGHT POLARIZING GUIDE MODULE
BACKPLANE FOOTPRINT**

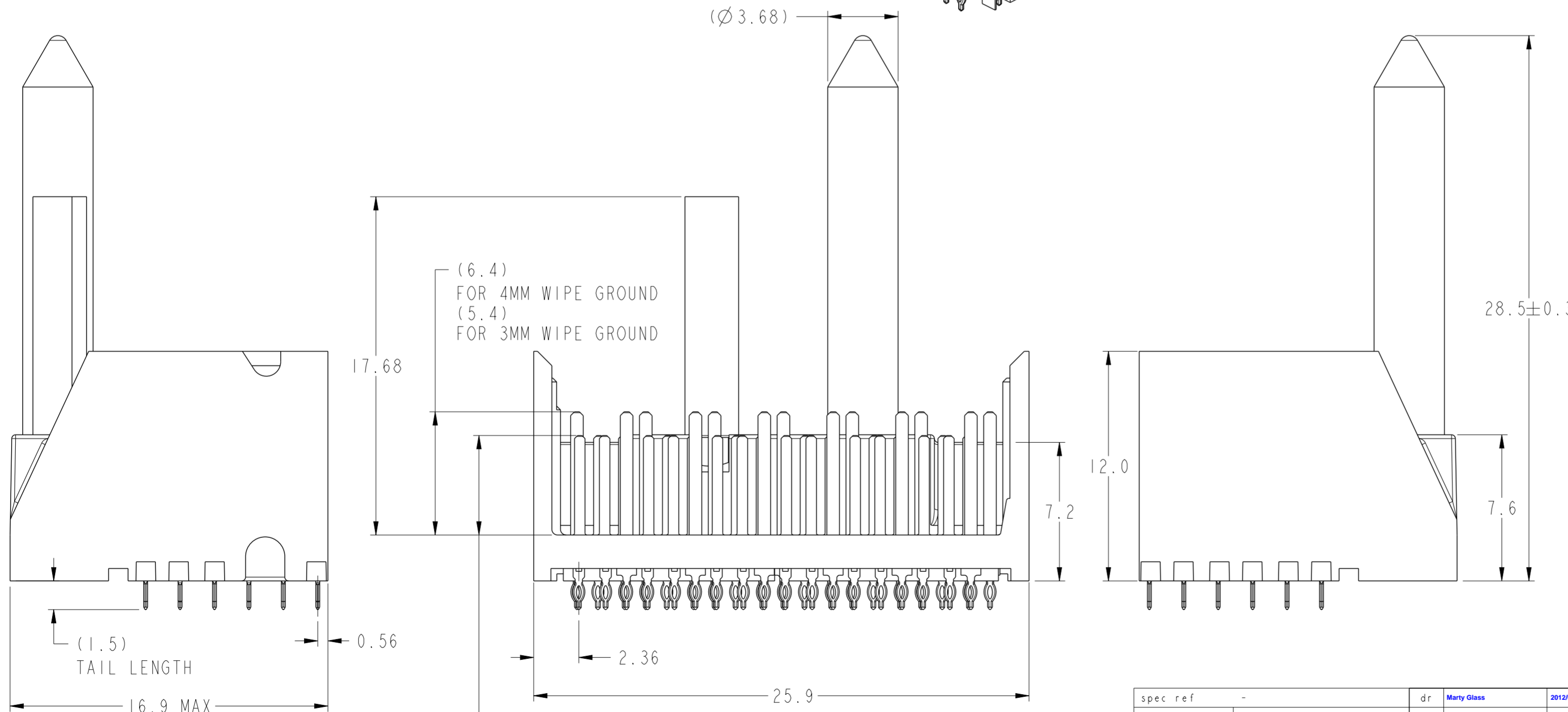

(5.2)
FOR 4MM WIPE SIGNAL
(4.2)
FOR 3MM WIPE SIGNAL

spec ref	-	dr	Mary Glass	2012/02/09	projection	MM	size	A2	scale	5:1	
tolerance std	ASME Y14.5	eng	Sander Soe	2013/03/20	chr	-	ecn no	ELX-8-14229-1	rel level	Released	
surface	✓	appr	Chen-Hong Tan	2013/04/09	product family	XCEDE HD	rel level	Released	cat. no.	10119130	
ASME Y14.5	linear	0.X	±0.3	0.XX	±0.10	0.XXX	±0.05	angular	0°	±2°	
TOLERANCES UNLESS OTHERWISE SPECIFIED		www.fci.com		VERTICAL HEADER ASSEMBLY XCEDE HD 6 PAIR, 6 COLUMN		Product - Customer Drw		sheet 7 of 8		rev	B



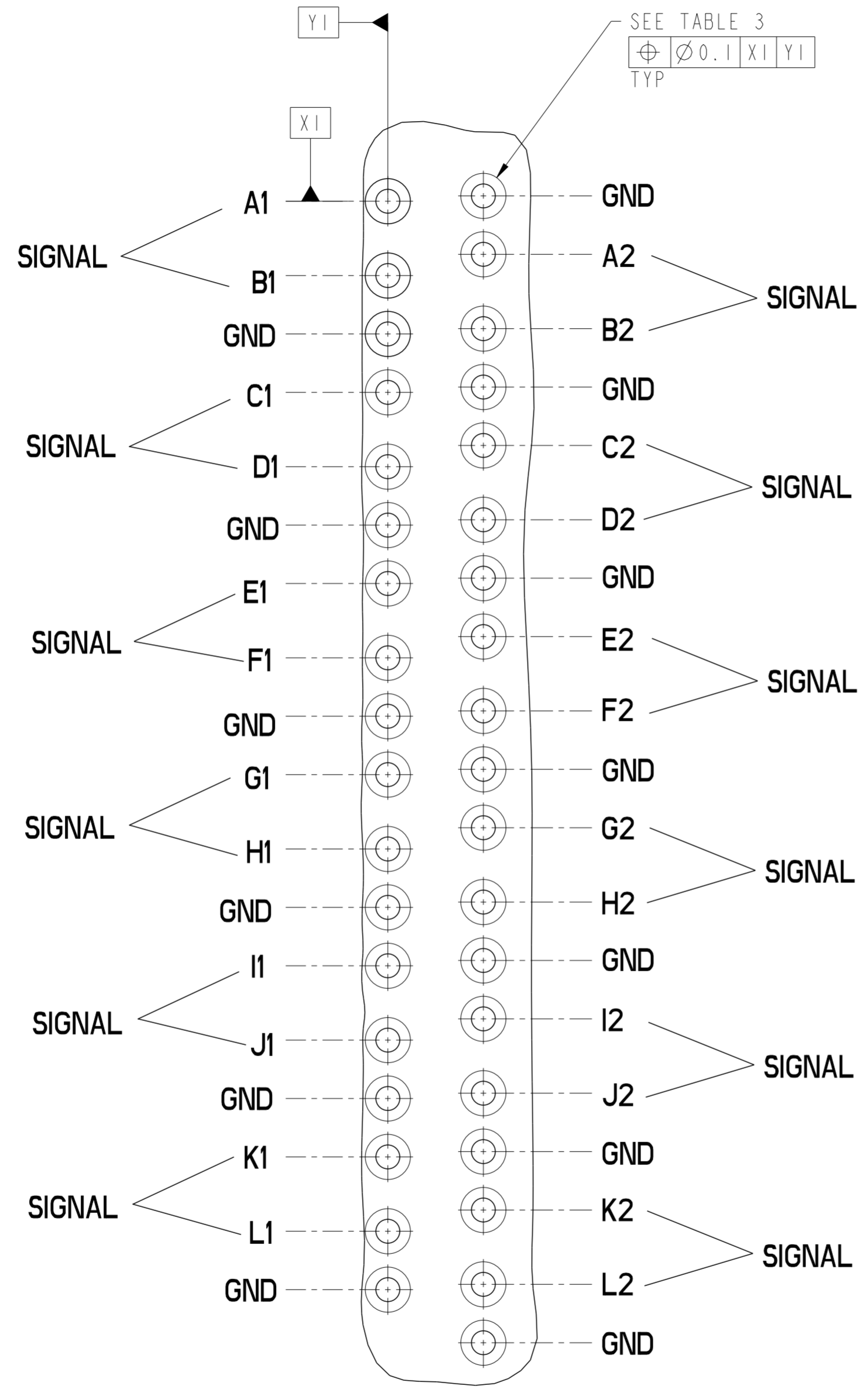

DETAIL A
SCALE 12:1
PINOUT DETAILS

TABLE 3		
	COMPLIANT PIN DRILL Ø0.55[0.0217"]	COMPLIANT PIN DRILL Ø0.45[0.0117"]
PTH	Ø0.45±0.05	Ø0.36±0.05
DRILL	Ø0.55[0.0217"]	Ø0.45[0.0117"]
PAD	Ø0.85	Ø0.75

NOTES:

1. CONNECTOR MATERIALS
SHROUD : HIGH-TEMP POLYMER, COLOR : BLACK, UL94V-0
CONTACTS : HIGH PERFORMANCE COPPER ALLOY
2. PRODUCT SPECIFICATION : GS-12-0936
3. APPLICATION SPECIFICATION : GS-20-0348
4. PRODUCT MARKING :
PART NUMBER (10119130-X0C-XXXLF)
"FCI" AND DATE CODE (FCI P#####)
- ⑤ NOTCH DESIGNATES "ROW A" SIDE OF CONNECTOR. NOTCH FEATURE ON OPPOSITE FOR PRODUCT MARKING.
- ⑥ PLATING THICKNESS OF SIGNAL & GROUND CONTACT ARE DETERMINED BY PLATING CODE, REFER TO P/N TREE ON SHEET 1.
7. PACKAGING MEETS GS-14-920 LEAD-FREE LABELING SPECIFICATION.
- ⑧ GUIDE-PIN STYLE DESIGNATION ONLY APPLIES TO MODULE VERSIONS THAT REQUIRE GUIDE-PIN HARDWARE. FOR ALL NON-GUIDE-PIN VERSIONS, THE DEFAULT DASH-NUMBER DIGIT IN THAT LOCATION IS STILL '0'.
- ⑨ SEE APPLICATION SPECIFICATION FOR ROUTING GUIDELINES, ADDITIONAL PTH GUIDELINES, MATED DIMENSIONS, GUIDE PIN SELECTION, ETC.
10. A $\triangle B$ SYMBOL WILL BE NEXT TO ANY DIMENSION, VIEW OR NOTE THAT HAS BEEN MODIFIED WITH THE CURRENT DRAWING REVISION.
- $\triangle B$ ⑪ OPTIONAL HOLE LOCATION FOR GROUNDED PIN OR ADDITIONAL GUIDE-PIN SUPPORT. SEE TABLE 1 SHEET 1 FOR ADDITIONAL DETAILS.
- $\triangle B$ ⑫ SCREW IS OPTIONAL AND ENGAGES WITH BOTTOM OF GUIDE PIN FROM BENEATH THE PCB FOR ADDITIONAL GUIDE-PIN SUPPORT.

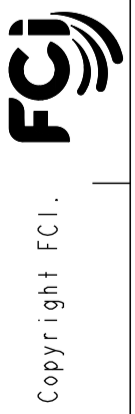

spec ref	-	dr	Mary Glass	2012/02/09	projection	MM	size	A2	scale	3:1				
tolerance std	ASME Y14.5	eng	Sander Soe	2013/03/20			ecn no	ELX-S-14229-1						
TOLERANCES UNLESS OTHERWISE SPECIFIED		chr	-	appr			Chen-Hong Tan	2013/04/09	product family	XCEDE HD	rel level	Released		
surface	ASME Y14.5	linear	0.X	±0.3		TITLE VERTICAL HEADER ASSEMBLY XCEDE HD 6 PAIR, 6 COLUMN	dwg no 10119130	rev B	Product - Customer Drw		sheet 8 of 8			
		angular	0°	±2°					www.fci.com	cat. no.	-		-	
PDS: Rev : B STATUS: Released Printed: Apr 10, 2013														