MULTIGIG RT* Power Modules

1. SCOPE

1.1. Content

This specification covers performance, tests and quality requirements for the Tyco Electronics MULTIGIG RT* Power Modules.

1.2. Qualification

When tests are performed on the subject product line, procedures specified in Figure 1 shall be used. All inspections shall be performed using the applicable inspection plan and product drawing.

1.3. Qualification Test Results

Successful qualification testing on the subject product line was completed on 03Sep02. The Qualification Test Report number for this testing is 501-538. This documentation is on file at and available from Engineering Practices and Standards (EPS).

2. APPLICABLE DOCUMENTS

The following documents form a part of this specification to the extent specified herein. Unless otherwise specified, the latest edition of the document applies. In the event of conflict between the requirements of this specification and the product drawing, the product drawing shall take precedence. In the event of conflict between the requirements of this specification and the referenced documents, this specification shall take precedence.

2.1. Tyco Electronics Documents

- ! 109 Series: Test Specifications as indicated in Figure 1
- ! 109-197: Test Specification (AMP Test Specifications vs EIA and IEC Test Methods)
- ! 114-13062: Application Specification (MULTIGIG RT Power Modules)
- ! 501-538: Qualification Test Report (MULTIGIG RT* Power Modules)
- ! 502-1130: Engineering Report (Current Rating of MULTIGIG RT* Power Modules)

2.2. Commercial Standards

- ! Bellcore (Telcordia)GR-1217: Generic Requirements for Separable Electrical Connectors Used in Telecommunications Hardware
- ! EIA-364: Electrical Connector/Socket Test Procedures Including Environmental Classifications

3. REQUIREMENTS

3.1. Design and Construction

Product shall be of the design, construction and physical dimensions specified on the applicable product drawing.

3.2. Materials

Materials used in the construction of this product shall be as specified on the applicable product drawing.

3.3. Ratings

- ! Voltage: 250 volts AC
- ! Current: 20 amperes maximum. For applications, see Engineering Report 502-1130 for current rating test results for various printed circuit board copper plane thicknesses and number of connector positions energized. Actual test board drawings used in this testing are available to customers for correlation purposes.
- ! Temperature: -55 to 105°C

3.4. Performance and Test Description

Product is designed to meet the electrical, mechanical and environmental performance requirements specified in Figure 1. Unless otherwise specified, all tests shall be performed at ambient environmental conditions per EIA-364.

3.5. Test Requirements and Procedures Summary

Test Description	Requirement	Procedure
Initial examination of product.	Meets requirements of product drawing.	EIA-364-18. Visual and dimensional (C of C) inspection per product drawing.
Final examination of product.	Meets visual requirements.	EIA-364-18. Visual inspection.
ELECTRICAL		
Low level contact resistance, circuit.	5 milliohms maximum initial. ΔR 5 milliohms maximum.	EIA-364-23. Subject specimens to 100 milliamperes maximum and 20 millivolts maximum open circuit voltage. See Figure 3.
Low level resistance, compliant pin.	1 milliohm maximum initial. ΔR 1 milliohm maximum change.	EIA-364-23. Subject specimens to 100 milliamperes maximum and 20 millivolts maximum open circuit voltage. See Figure 4.
Insulation resistance.	10000 megohms minimum.	EIA-364-21. Test between adjacent contacts of mated specimens at 500 volts DC.
Withstanding voltage.	1 minute hold with no breakdown or flashover.	EIA-364-20, Condition I. 1,500 volts AC or DC at sea level. Test between adjacent contacts of mated specimens.

Figure 1 (continued)

Test Description	Requirement	Procedure
MECHANICAL		
Vibration, sinusoidal.	No discontinuities of 1 microsecond or longer duration. See Note.	EIA-364-28, Test Condition II. Subject mated specimens to 10-500-10 Hz traversed in 15 minutes with 1.5 mm [.06 in] maximum total excursion or 10 G's, whichever is less. 2 hours in each of 3 mutually perpendicular planes. See Figure 5.
Mechanical shock.	No discontinuities of 1 microsecond or longer duration. See Note.	EIA-364-27, Method H. Subject mated specimens to 30 G's half-sine shock pulses of 11 milliseconds duration. 3 shocks in each direction applied along 3 mutually perpendicular planes, 18 total shocks. See Figure 5.
Durability.	See Note.	EIA-364-9. Mate and unmate specimens for 200 cycles at a maximum rate of 500 cycles per hour.
Mating force.	20 N [4.5 lbf] maximum per connector.	EIA-364-13. Measure force necessary to mate specimens at a maximum rate of 12.7 mm [.5 in] per minute.
Unmating force.	20 N [4.5 lbf] maximum per connector.	EIA-364-13. Measure force necessary to unmate specimens at a maximum rate of 12.7 mm [.5 in] per minute.
Contact retention.	No axial displacement with a force of 5 N [1.12 lbf] applied.	EIA 364-29. Apply specified axial force to contacts in the mating direction at a maximum rate of 2.54 mm [.1 in] per minute and hold for 6 seconds.
Compliant pin insertion.	50 N [11.2 lbf] maximum average per pin.	AMP Spec 109-41. Measure force necessary to correctly apply a connector assembly to a printed circuit board at a maximum rate of 12.7 mm [.5 in] per minute.

Figure 1 (continued)

Test Description	Requirement	Procedure
Compliant pin retention.	13.34 N [3 lbf] minimum average per pin.	AMP Spec 109-30. Measure force necessary to unseat a single contact (6 pins) in a correctly applied connector assembly from its printed circuit board hole at a maximum rate of 12.7 mm [.5 in] per minute.
Minute disturbance.	See Note.	Unmate and mate specimens a distance of approximately 0.1 mm [.004 in].
ENVIRONMENTAL		
Thermal shock.	See Note.	EIA-364-32, Test Condition VII. Subject mated specimens to 5 cycles between -55 and 105°C.
Humidity-temperature cycling.	See Note.	EIA-364-31, Method III. Subject mated specimens to 10 cycles (10 days) between 25 and 65°C at 80 to 100% RH.
Temperature life with electrical load.	See Note.	EIA-364-17, Method B, Test Condition 4, Test Time Condition C. Subject mated specimens energized with 21.5 amperes to 105°C for 500 hours.
Mixed flowing gas.	See Note.	EIA-364-65, Class IIA (4 gas). Subject specimens to environmental Class IIA for 20 days (10 days mated and 10 days unmated).
Dust contamination.	See Note.	EIA-364-91. Subject unmated specimens (both connector mating halves) to dust contamination for 1 hour. Dust composition #1, benign.

NOTE

Shall meet visual requirements, show no physical damage, and meet requirements of additional tests as specified in the Product Qualification and Requalification Test Sequence shown in Figure 2.

Figure 1 (end)

3.6. Product Qualification and Requalification Test Sequence

Test or Examination	Test Group (a)				
	1	2	3	4	5
	Test Sequence (b)				
Initial examination of product	1	1	1	1	1
Low level contact resistance, circuit	4,7	4,7,9,12	2,5,7,10	2,5,7,9,12,14,16,19	
Low level resistance, compliant pin	5,8	5,13	3,11	3,10,17	
Insulation resistance		14			
Withstanding voltage		15			
Vibration			8		
Mechanical shock			9		
Durability		6	4	4,18(c)	
Mating force	2,10	2,17	13		
Unmating force	3,9	3,16	12		
Contact retention					4
Press-fit compliant pin/terminal insertion					2
Press-fit compliant pin/terminal retention	11	18	14	20	3
Minute disturbance				15	
Thermal shock		10			
Humidity-temperature cycling		11			
Temperature life with electrical load	6				
Mixed flowing gas				6(d),8(d),11(e),13(e)	
Dust contamination		8	6		
Final examination of product	12	19	15	21	5

NOTE

- (a) See paragraph 4.1.A.
- (b) Numbers indicate sequence in which tests are performed.
- (c) Perform 100 cycles of durability before, and 100 cycles after mixed flowing gas testing.
- (d) Exposure interval of 5 days with specimens unmated.
- (e) Exposure interval of 5 days with specimens mated.

Figure 2

4. QUALITY ASSURANCE PROVISIONS

4.1. Qualification Testing

A. Specimen Selection

Specimens shall be prepared in accordance with applicable Instruction Sheets and shall be selected at random from current production. Test groups 1, 3, 4 and 5 shall each consist of 8 specimens. Test group 2 shall consist of 16 specimens.

B. Test Sequence

Qualification inspection shall be verified by testing specimens as specified in Figure 2.

4.2. Requalification Testing

If changes significantly affecting form, fit or function are made to the product or manufacturing process, product assurance shall coordinate requalification testing, consisting of all or part of the original testing sequence as determined by development/product, quality and reliability engineering.

4.3. Acceptance

Acceptance is based on verification that the product meets the requirements of Figure 1. Failures attributed to equipment, test setup or operator deficiencies shall not disqualify the product. If product failure occurs, corrective action shall be taken and specimens resubmitted for qualification. Testing to confirm corrective action is required before resubmittal.

4.4. Quality Conformance Inspection

The applicable quality inspection plan shall specify the sampling acceptable quality level to be used. Dimensional and functional requirements shall be in accordance with the applicable product drawing and this specification.

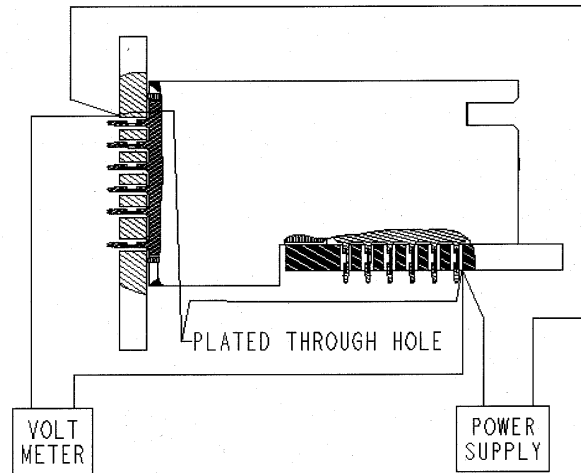

Figure 3
Low Level Contact Resistance Measurement Points

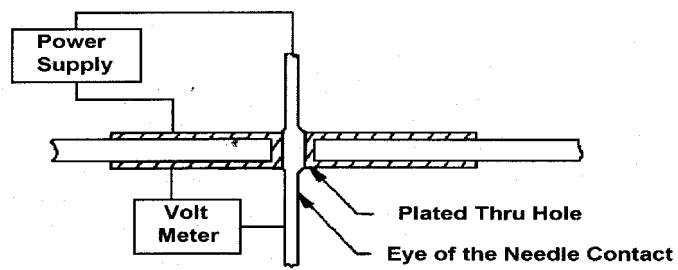

Figure 4
Low Level Resistance Measurement Points (Compliant Pin)

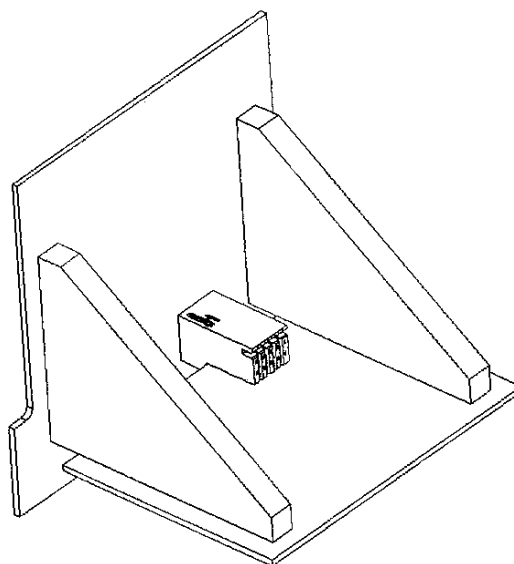

Figure 5
Vibration & Mechanical Shock Mounting Fixture