

LOC		DIST		REVISIONS				
P	LTR	DESCRIPTION	DATE	DWN	APVD			
H3		PART STATUS UPDATED IN PARTS LIST TABLE	23DEC2015	KJK	PS			

- NOTES:
- TRUE POSITION TOLERANCE OF POST TIPS APPLIES WHEN HEADERS ARE HELD FLAT AGAINST PRINTED CIRCUIT BOARD.
  - OBSOLETE PART NUMBER
  - .000100-.000200 BRIGHT TIN OVER .000050-.000100 NICKEL.
  - .000100-.000200 BRIGHT TIN-LEAD OVER .000050-.000100 NICKEL.
  - PRELIMINARY PART
  - .000100-.000200 MATTE TIN OVER .000050 NICKEL.

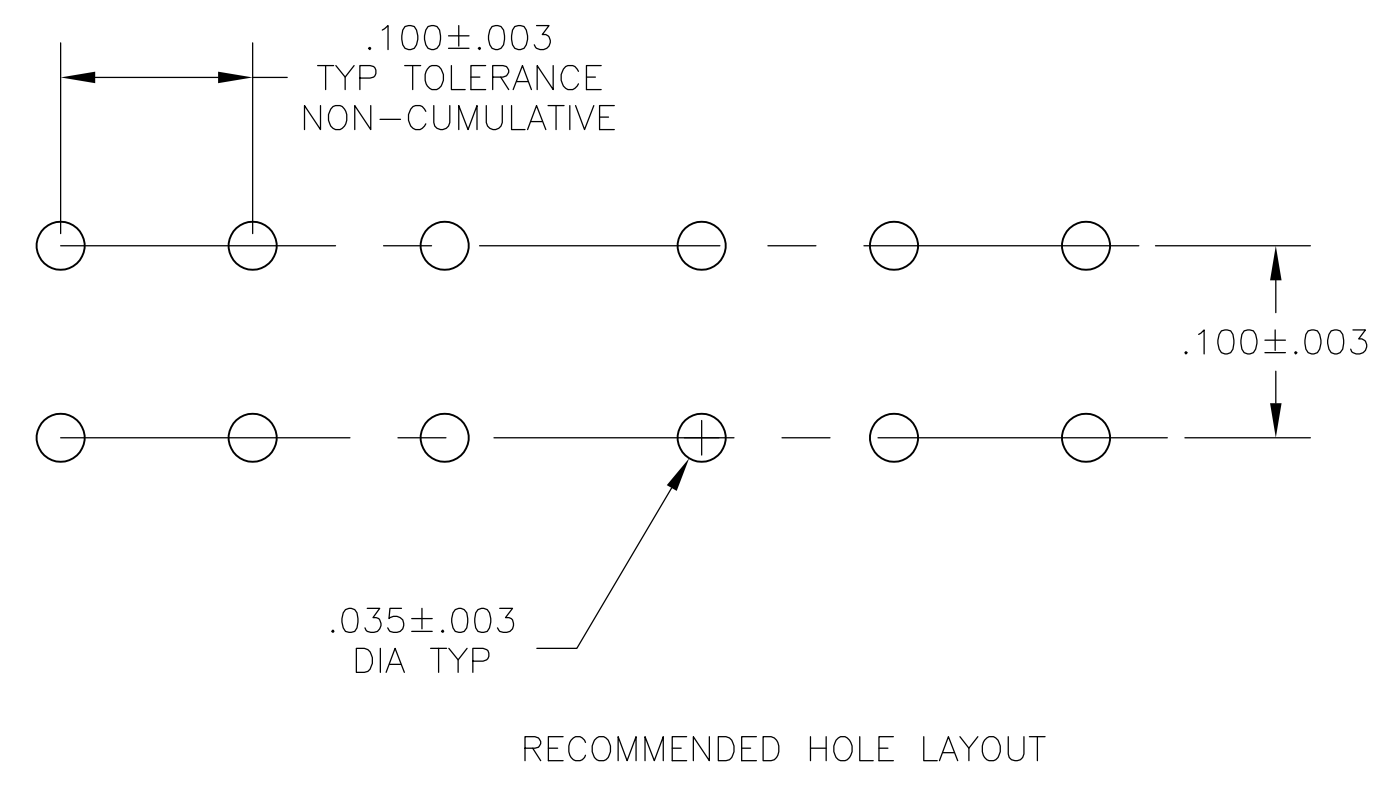
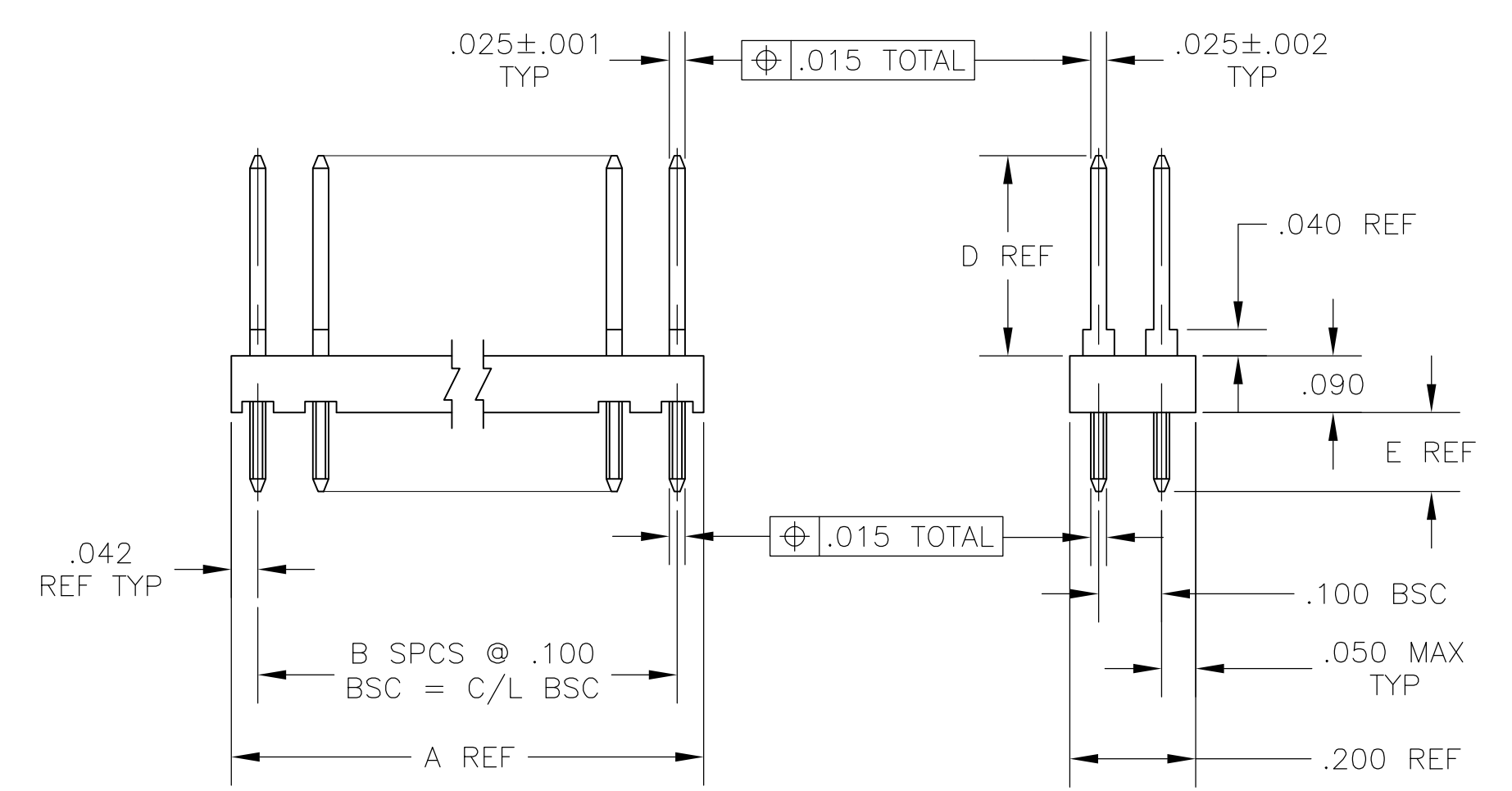

SEE SHEET 2 FOR LEAD FREE PART NUMBERS

FINISH	E	D	C	B	A	NO OF POSN	PART NUMBER
3	.125	.318	.500	5	.584	12	4-87543-3
3	.125	.318	4.100	41	4.184	80	4-87543-2
3	.125	.318	4.000	40	4.084	80	4-87543-1
4	.125	.318	3.900	39	3.984	80	4-87543-0
	.125	.318	3.800	38	3.884	78	3-87543-9
	.125	.318	3.700	37	3.784	76	3-87543-8
	.125	.318	3.600	36	3.684	74	3-87543-7
	.125	.318	3.500	35	3.584	72	3-87543-6
	.125	.318	3.400	34	3.484	70	3-87543-5
	.125	.318	3.300	33	3.384	68	3-87543-4
	.125	.318	3.200	32	3.284	66	3-87543-3
	.125	.318	3.100	31	3.184	64	3-87543-2
	.125	.318	3.000	30	3.084	62	3-87543-1
	.125	.318	2.900	29	2.984	60	3-87543-0
	.125	.318	2.800	28	2.884	58	2-87543-9
	.125	.318	2.700	27	2.784	56	2-87543-8
	.125	.318	2.600	26	2.684	54	2-87543-7
	.125	.318	2.500	25	2.584	52	2-87543-6
	.125	.318	2.400	24	2.484	50	2-87543-5
	.125	.318	2.300	23	2.384	48	2-87543-4
	.125	.318	2.200	22	2.284	46	2-87543-3
	.125	.318	2.100	21	2.184	44	2-87543-2
	.125	.318	2.000	20	2.084	42	2-87543-1
	.125	.318	1.900	19	1.984	40	2-87543-0
	.125	.318	1.800	18	1.884	38	1-87543-9
	.125	.318	1.700	17	1.784	36	1-87543-8
	.125	.318	1.600	16	1.684	34	1-87543-7
	.125	.318	1.500	15	1.584	32	1-87543-6
	.125	.318	1.400	14	1.484	30	1-87543-5
	.125	.318	1.300	13	1.384	28	1-87543-4
	.125	.318	1.200	12	1.284	26	1-87543-3
	.125	.318	1.100	11	1.184	24	1-87543-2
	.125	.318	1.000	10	1.084	22	1-87543-1
	.125	.318	.900	9	.984	20	1-87543-0
	.125	.318	.800	8	.884	18	87543-9
	.125	.318	.700	7	.784	16	87543-8
	.125	.318	.600	6	.684	14	87543-7
	.125	.318	.500	5	.584	12	87543-6
	.125	.318	.400	4	.484	10	87543-5
	.125	.318	.300	3	.384	8	87543-4
	.125	.318	.200	2	.284	6	87543-3
	.125	.318	.100	1	.184	4	87543-2
A	.125	.318	-	-	.084	2	87543-1

THIS DRAWING IS A CONTROLLED DOCUMENT.

DIMENSIONS: INCHES. TOLERANCES UNLESS OTHERWISE SPECIFIED:

0. PLC	± .005
1. PLC	± .005
2. PLC	± .005
3. PLC	± .005
4. PLC	± .005
ANGLES	± .005

MATERIAL: H30-GLASS FILLED NYLON COLOR: BLACK CONTACT: PHOS BRONZE

FINISH: SEE TABLE

APPROVED: M.E. PASTEL 20 NOV 87, T.C. CLARK 20 NOV 87, T.C. CLARK 20 NOV 87

NAME: ASSEMBLY, MOD II, HEADER, DOUBLE ROW, .100X.100

SIZE: A1, CASE CODE: 00779, DRAWING NO: 87543

WEIGHT: --

CUSTOMER DRAWING

SCALE: 4:1, SHEET: 1 OF 2, REV: H3

STE TE Connectivity

△	.125	.318	3.900	39	3.984	80	9-87543-0
	.125	.318	3.800	38	3.884	78	8-87543-9
	.125	.318	3.700	37	3.784	76	8-87543-8
	.125	.318	3.600	36	3.684	74	8-87543-7
	.125	.318	3.500	35	3.584	72	8-87543-6
	.125	.318	3.400	34	3.484	70	8-87543-5
	.125	.318	3.300	33	3.384	68	8-87543-4
	.125	.318	3.200	32	3.284	66	8-87543-3
	.125	.318	3.100	31	3.184	64	8-87543-2
	.125	.318	3.000	30	3.084	62	8-87543-1
	.125	.318	2.900	29	2.984	60	8-87543-0
	.125	.318	2.800	28	2.884	58	7-87543-9
	.125	.318	2.700	27	2.784	56	7-87543-8
	.125	.318	2.600	26	2.684	54	7-87543-7
	.125	.318	2.500	25	2.584	52	7-87543-6
	.125	.318	2.400	24	2.484	50	7-87543-5
	.125	.318	2.300	23	2.384	48	7-87543-4
	.125	.318	2.200	22	2.284	46	7-87543-3
	.125	.318	2.100	21	2.184	44	7-87543-2
	.125	.318	2.000	20	2.084	42	7-87543-1
	.125	.318	1.900	19	1.984	40	7-87543-0
	.125	.318	1.800	18	1.884	38	6-87543-9
	.125	.318	1.700	17	1.784	36	6-87543-8
	.125	.318	1.600	16	1.684	34	6-87543-7
	.125	.318	1.500	15	1.584	32	6-87543-6
	.125	.318	1.400	14	1.484	30	6-87543-5
	.125	.318	1.300	13	1.384	28	6-87543-4
	.125	.318	1.200	12	1.284	26	6-87543-3
	.125	.318	1.100	11	1.184	24	6-87543-2
	.125	.318	1.000	10	1.084	22	6-87543-1
	.125	.318	.900	9	.984	20	6-87543-0
	.125	.318	.800	8	.884	18	5-87543-9
	.125	.318	.700	7	.784	16	5-87543-8
	.125	.318	.600	6	.684	14	5-87543-7
	.125	.318	.500	5	.584	12	5-87543-6
	.125	.318	.400	4	.484	10	5-87543-5
	.125	.318	.300	3	.384	8	5-87543-4
	.125	.318	.200	2	.284	6	5-87543-3
	.125	.318	.100	1	.184	4	5-87543-2
△	.125	.318	-	-	.084	2	5-87543-1
FINISH	E	D	C	B	A	NO OF POSN	PART NUMBER

THIS DRAWING IS A CONTROLLED DOCUMENT.		DWN M.E. PASTEL 20 NOV 87	 TE Connectivity ASSEMBLY, MOD II, HEADER, DOUBLE ROW, .100X.100	
DIMENSIONS: INCHES		CHK T.C. CLARK 20 NOV 87		
TOLERANCES UNLESS OTHERWISE SPECIFIED:		APPO T.C. CLARK 20 NOV 87	NAME	
0 PLC ± - 1 PLC ± - 2 PLC ± - 3 PLC ± - 4 PLC ± - ANGLES ± -		PRODUCT SPEC	RESTRICTED TO	
MATERIAL HSG-GLASS FILLED NYLON COLOR: BLACK CONTACT: PHOS BRONZE		FINISH SEE TABLE	WEIGHT -	SIZE A1
		SCALE 4:1	CAGE CODE 00779	DRAWING NO 87543
		CUSTOMER DRAWING	SHEET 2	OF 2
			REV H3	