

LOC	DIST	REV	DATE	BY	APPV
CM	00	R1	05NOV2015	NK	PQ

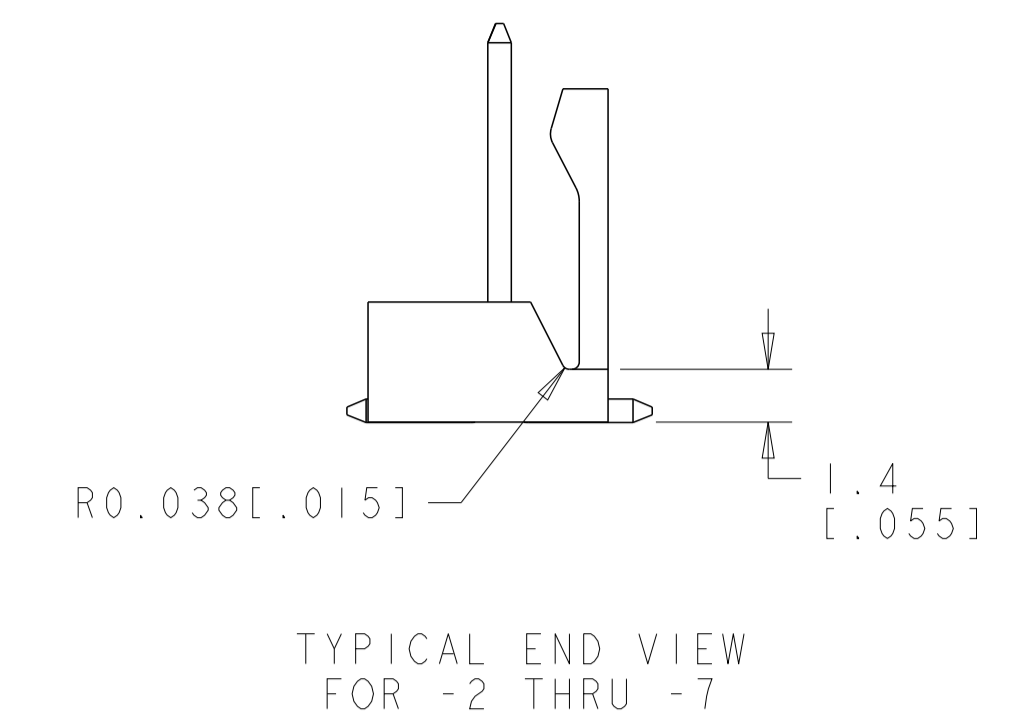

- 1. POST WITHSTAND 13 NEWTONS (3 LBS) MIN AXIAL FORCE IN DIRECTION SHOWN WITHOUT DISLODGING.
- 2. MEASURED AT -A-.
- 3. PARTS COMPLY WITH SOLDERABILITY SPEC 109-11-2.
- 4. MATERIAL:
HOUSING: NYLON, 4/6, HIGH TEMP, BLACK.
POST - COPPER ALLOY (SEE TABLE FOR PLATING).
- 5. COORDINATE DIMENSION APPLIES FROM CENTER OF ACTUAL FEATURE.
- 6. POSTS TO BE MEASURED WHEN STRIP HELD FLAT.
- 7. PLATING: GOLD PLATE AREA, 0.00038 [0.00015] GOLD OR 0.00008 [0.00003] MIN GOLD FLASH OVER 0.00030 [0.00012] PALLADIUM NICKEL, PER TE CONNECTIVITY'S DISCRETION, ALL SIDES, OVER NICKEL UNDERPLATE, 0.00127 [0.00050] MIN, ALL SIDES AND ENTIRE LENGTH OF POST.
- 8. MATTE TIN PLATE AREA, 0.00381-0.00889 [0.000150-.000350] THICK, ALL FOUR SIDES, 3.56 [0.140] MIN.
- 9. DIMENSIONS IN BRACKETS ARE IN INCHES.
- 10. TE LOGO, UL, AND CSA TRADEMARKS TO APPEAR ON THIS SURFACE.
- 11. MATTE TIN PLATE AREA, 0.00381-0.00889 [0.000150-.000350] THICK, ALL FOUR SIDES, 3.56 [0.140] MIN.
- 12. OBSOLETE PARTS: OBSOLETE CIS STREAMLINING PER D.RENAUD/D.SINISI

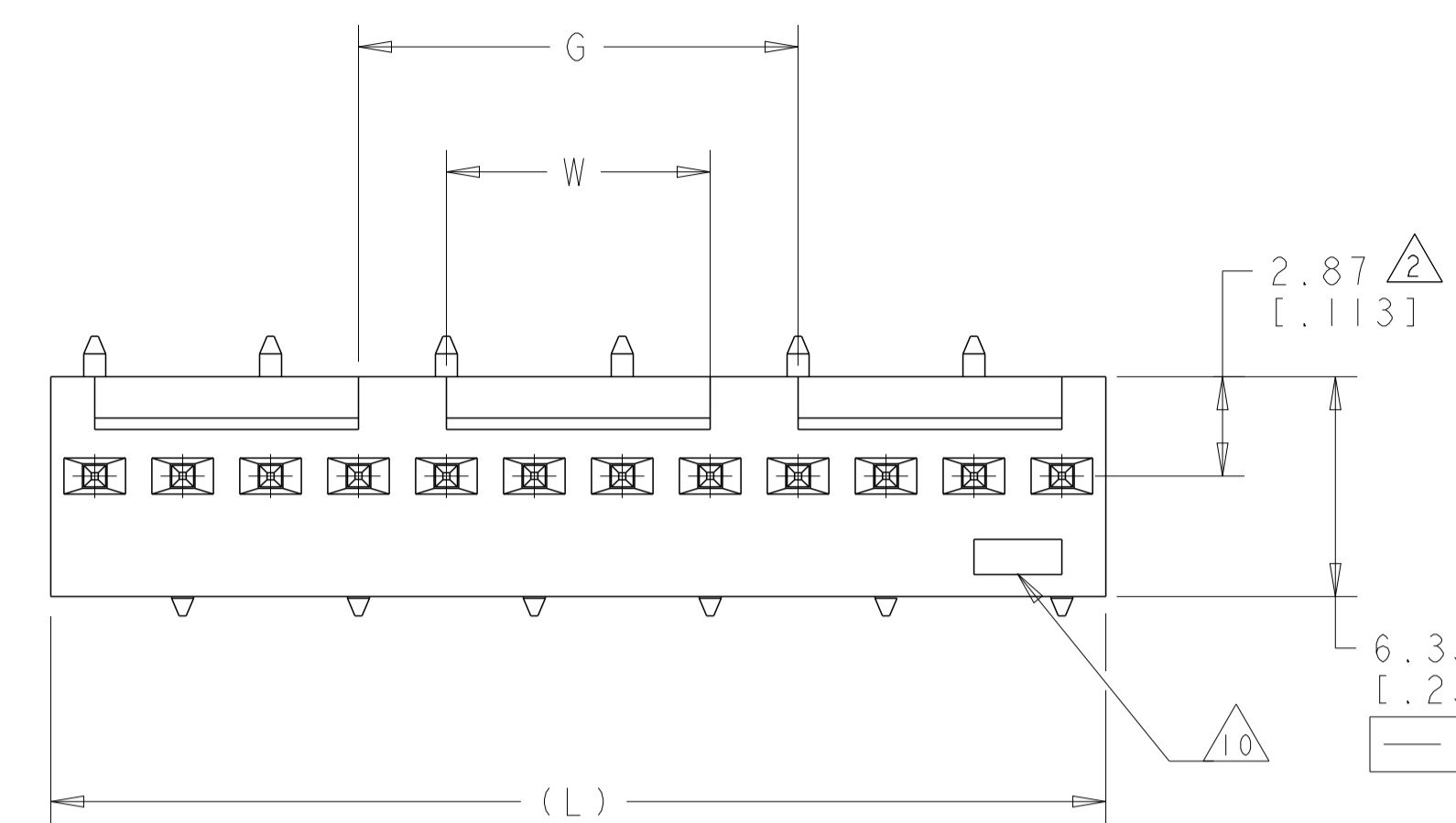
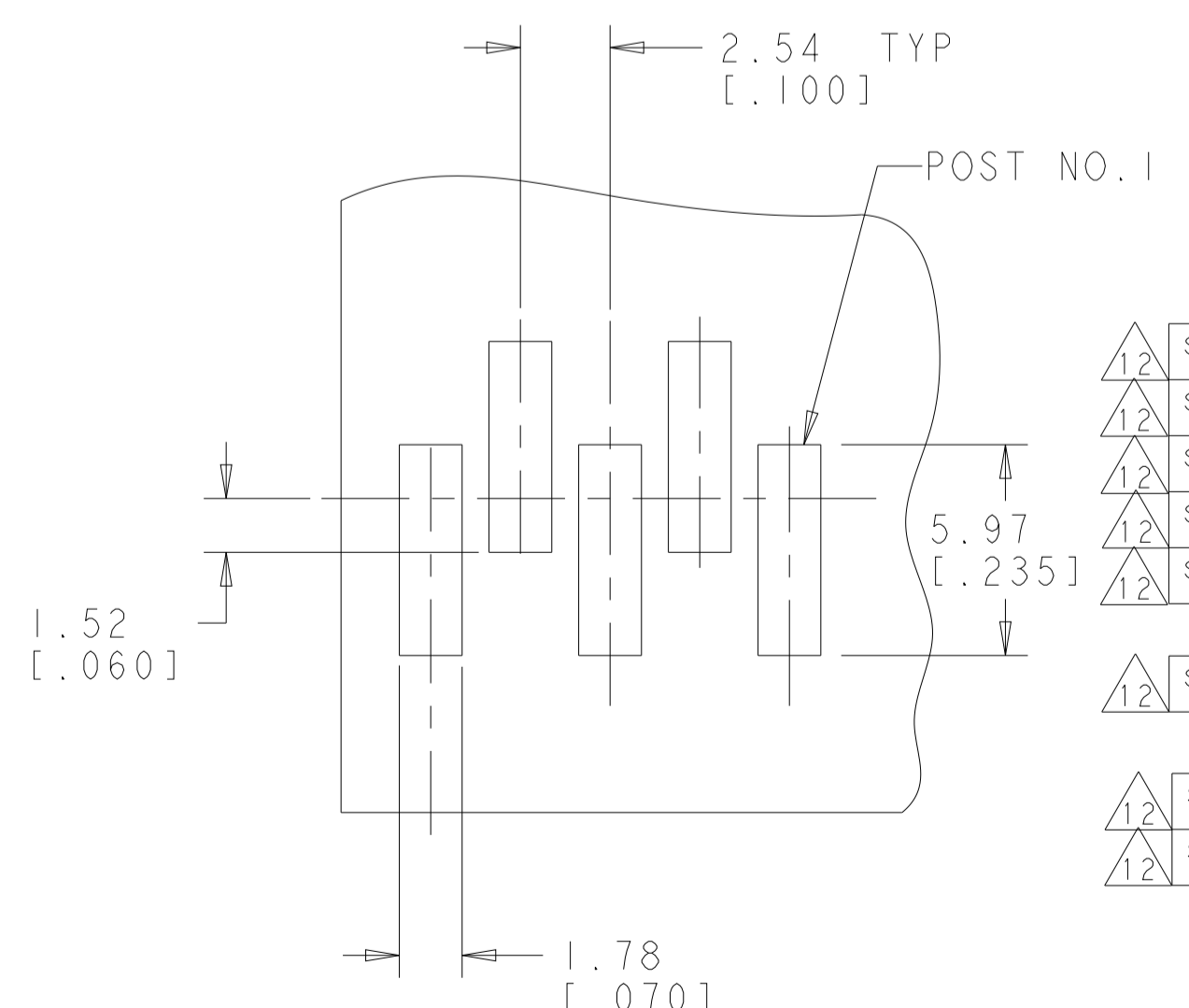
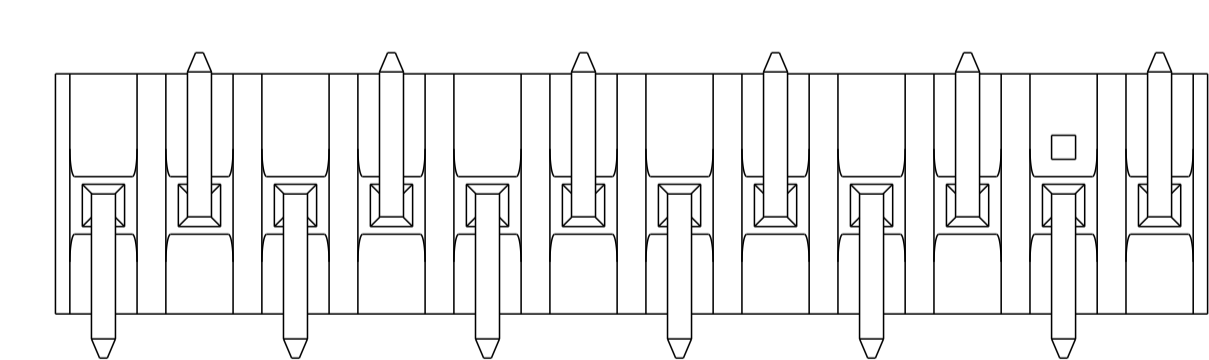
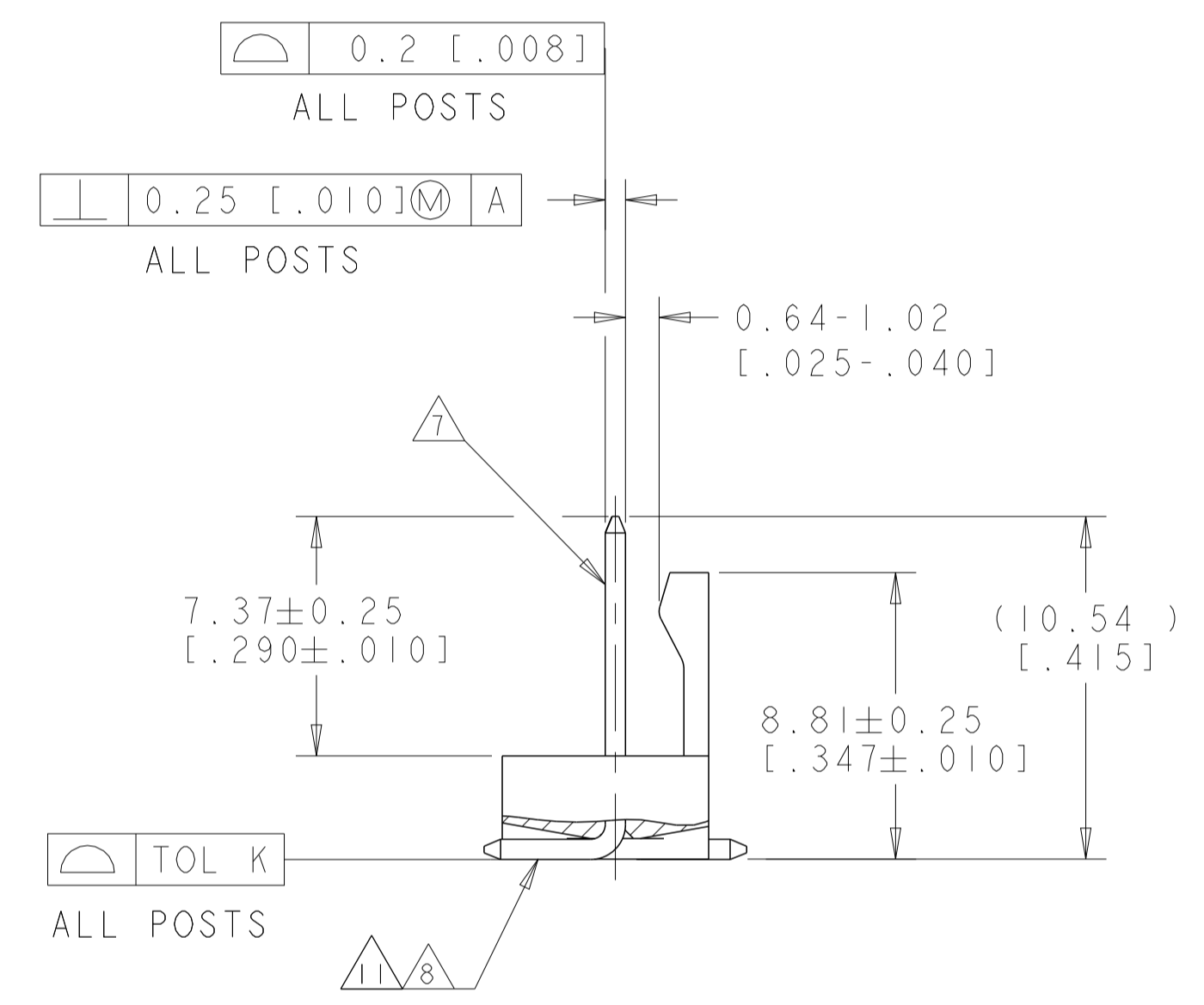
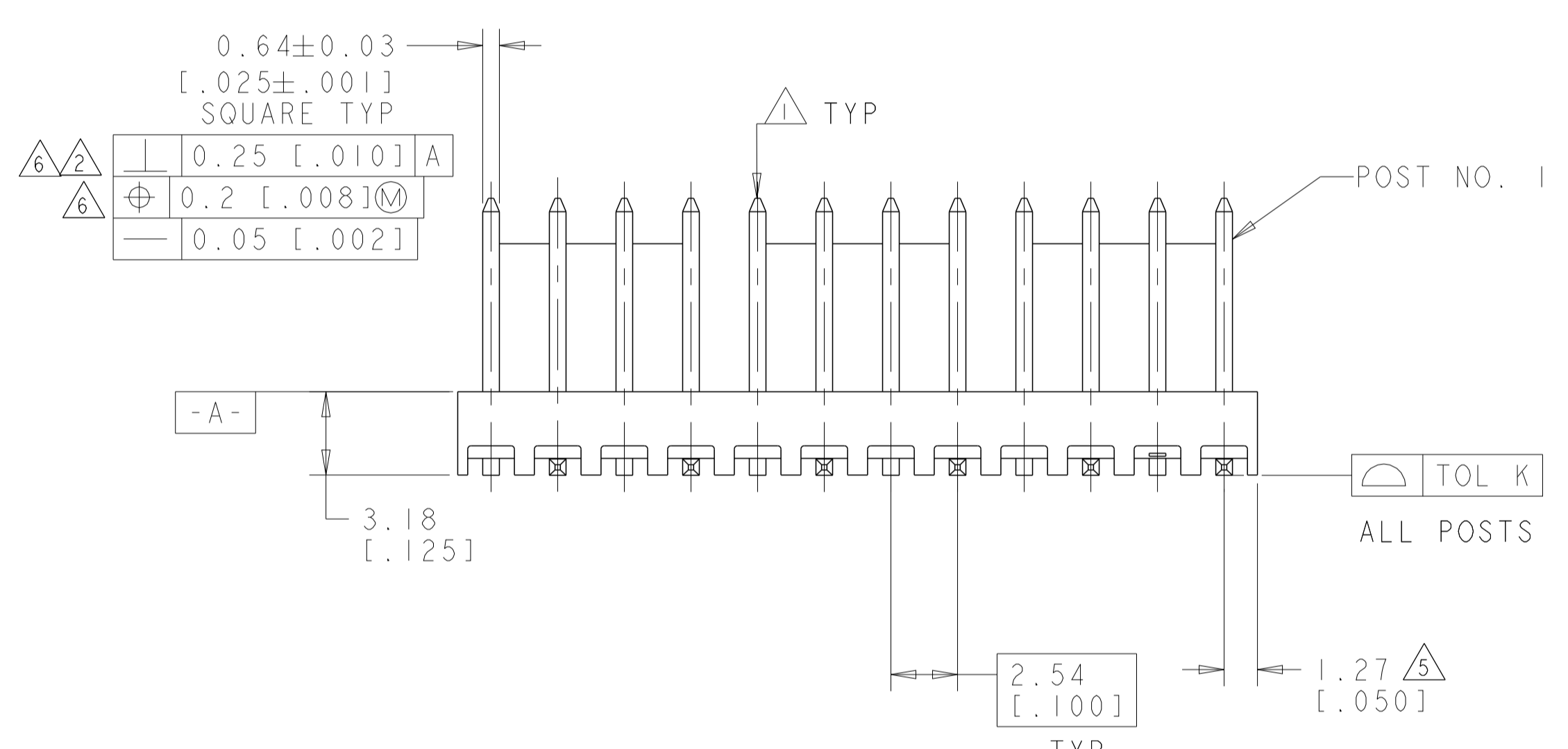

POST FINISH	TOL K	W	G	L	NO OF POSN	PART NO	
7, 11		0.15 [0.006]	7.62 [0.300]	12.70 [0.500]	30.48 [1.200]	12	4-647167-2
		0.15 [0.006]	-	10.16 [0.400]	27.94 [1.100]	11	4-647167-1
		0.15 [0.006]	-	7.62 [0.300]	25.40 [1.000]	10	4-647167-0
		0.15 [0.006]	-	5.08 [0.200]	22.86 [0.900]	9	3-647167-9
		0.15 [0.006]	-	2.54 [0.100]	20.32 [0.800]	8	3-647167-8
		0.15 [0.006]	-	-	17.78 [0.700]	7	3-647167-7
		0.15 [0.006]	-	-	15.24 [0.600]	6	3-647167-6
		0.15 [0.006]	-	-	12.70 [0.500]	5	3-647167-5
		0.15 [0.006]	-	-	10.16 [0.400]	4	3-647167-4
		0.15 [0.006]	-	-	7.62 [0.300]	3	3-647167-3
		0.15 [0.006]	-	-	5.08 [0.200]	2	3-647167-2
		0.15 [0.006]	7.62 [0.300]	12.70 [0.500]	30.48 [1.200]	12	4-647167-2
		0.15 [0.006]	-	10.16 [0.400]	27.94 [1.100]	11	1-647167-1
		0.15 [0.006]	-	7.62 [0.300]	25.40 [1.000]	10	1-647167-0
		0.15 [0.006]	-	5.08 [0.200]	22.86 [0.900]	9	647167-9
		0.15 [0.006]	-	2.54 [0.100]	20.32 [0.800]	8	647167-8
		0.15 [0.006]	-	-	17.78 [0.700]	7	647167-7
		0.15 [0.006]	-	-	15.24 [0.600]	6	647167-6
		0.15 [0.006]	-	-	12.70 [0.500]	5	647167-5
		0.15 [0.006]	-	-	10.16 [0.400]	4	647167-4
		0.15 [0.006]	-	-	7.62 [0.300]	3	647167-3
		0.15 [0.006]	-	-	5.08 [0.200]	2	647167-2

- 12 OBSOLETE
- 12 SUP 4-647167-1
- 12 SUP 4-647167-0
- 12 SUP 3-647167-9
- 12 SUP 3-647167-8
- 12 SUP 3-647167-7
- 12 OBSOLETE
- 12 SUP 3-647167-5
- 12 OBSOLETE
- 12 SUP 3-647167-3
- 12 SUP 3-647167-2

RECOMMENDED MOUNTING HOLE PATTERN FOR USE WITH 0.25 [0.010] THICK STENCIL

THIS DRAWING IS A CONTROLLED DOCUMENT. DIMENSIONS: mm [INCHES]. TOLERANCES UNLESS OTHERWISE SPECIFIED: 0 PLC ±, 1 PLC ±, 2 PLC ±, 3 PLC ±, 4 PLC ±, ANGLES ±30°. MATERIAL: 4. FINISH: 4. CUSTOMER DRAWING. SCALE: 5:1. SHEET 1 OF 1. REV 1.

OWN: R. WHITAKER, 4-NOV-2001. CHK: D. BOSSI, 14-NOV-2001. APPV: D. BOSSI, 14-NOV-2001. NAME: MTA-100 HEADER ASSEMBLY, SURFACE MOUNT, FRICTION LOCK, .025 SQUARE STRAIGHT POST, .000015 GOLD. SIZE: A100779. CAGE CODE: 647167. WEIGHT: -. RESTRICTED TO: -. CUSTOMER DRAWING. SCALE: 5:1. SHEET 1 OF 1. REV 1.

Mouser Electronics

Authorized Distributor

Click to View Pricing, Inventory, Delivery & Lifecycle Information:

[TE Connectivity:](#)

[1-647167-4](#)