

THIS DOCUMENT IS THE PROPERTY OF
KEYSTONE ELECTRONICS CORP. AND
SHALL NOT BE REPRODUCED, DISTRIBUTED
OR USED AS A BASIS FOR MANUFACTURE
WITHOUT PRIOR WRITTEN PERMISSION
FROM KEYSTONE ELECTRONICS CORP.

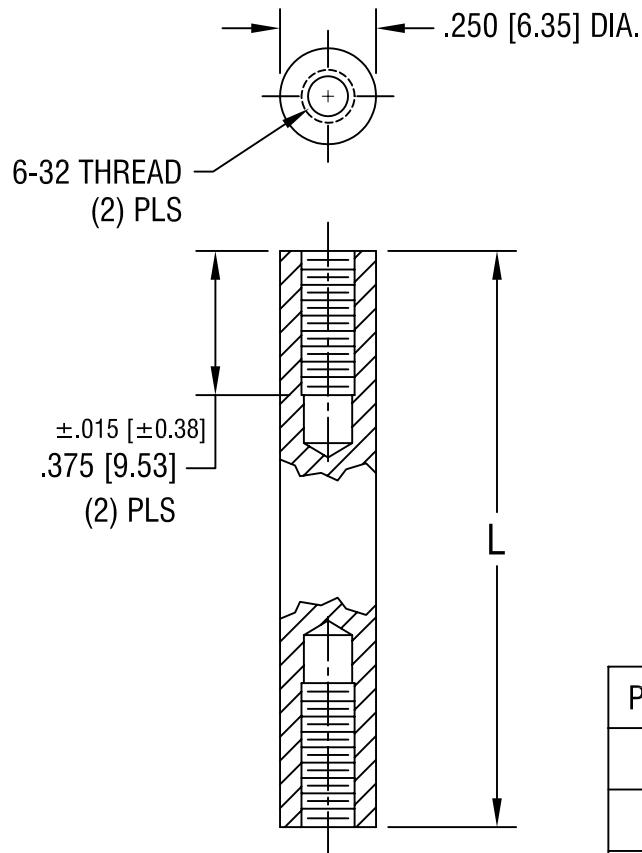

PART NO.	'L' DIM.
1881	1.250 [31.75]
1882	1.500 [38.10]
1883	1.750 [44.45]
1884	2.000 [50.80]
1885	2.250 [57.15]
1886	2.500 [63.50]

KEYSTONE ELECTRONICS CORP.

ASTORIA, N.Y. 11105-2017

PART NAME

THREADED ROUND STANDOFF

MATERIAL

BRASS

FINISH

ZINC PLATE

DRN BY

BOONE

DATE

7.6.82

APP'D

LN

SCALE

2X

8.17.94 CHANGE AS PER ECR 94-041

A

TOLERANCES

INCH [MM]

CODE

DWG NO.

DECIMAL

± .005 [± 0.15]

C/M

1881-1886

ANGULAR ± 1°
UNLESS OTHERWISE SPECIFIED

DATE

DESCRIPTION

REV.

Mouser Electronics

Authorized Distributor

Click to View Pricing, Inventory, Delivery & Lifecycle Information:

[Keystone Electronics:](#)

[1881](#)