

DRAWING FOR REFERENCE: This is subject to change without notice
12/05/2013

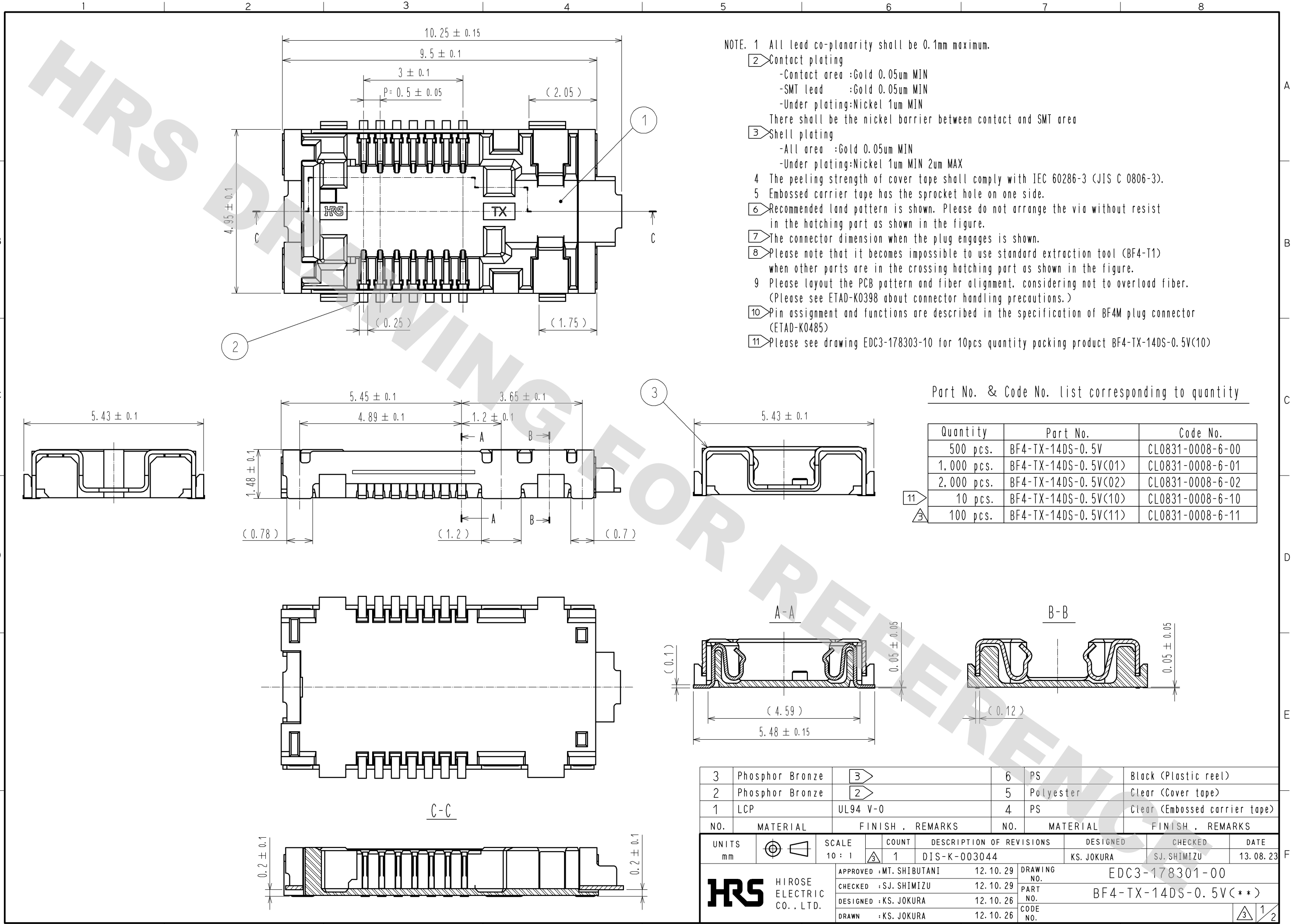

- NOTE. 1 All lead co-planarity shall be 0.1mm maximum.
- 2 Contact plating
 - Contact area :Gold 0.05um MIN
 - SMT lead :Gold 0.05um MIN
 - Under plating:Nickel 1um MIN
 There shall be the nickel barrier between contact and SMT area
 - 3 Shell plating
 - All area :Gold 0.05um MIN
 - Under plating:Nickel 1um MIN 2um MAX
 - 4 The peeling strength of cover tape shall comply with IEC 60286-3 (JIS C 0806-3).
 - 5 Embossed carrier tape has the sprocket hole on one side.
 - 6 Recommended land pattern is shown. Please do not arrange the via without resist in the hatching part as shown in the figure.
 - 7 The connector dimension when the plug engages is shown.
 - 8 Please note that it becomes impossible to use standard extraction tool (BF4-T1) when other parts are in the crossing hatching part as shown in the figure.
 - 9 Please layout the PCB pattern and fiber alignment, considering not to overload fiber. (Please see ETAD-K0398 about connector handling precautions.)
 - 10 Pin assignment and functions are described in the specification of BF4M plug connector (ETAD-K0485)
 - 11 Please see drawing EDC3-178303-10 for 10pcs quantity packing product BF4-TX-14DS-0.5V(10)

Part No. & Code No. list corresponding to quantity

Quantity	Part No.	Code No.
500 pcs.	BF4-TX-14DS-0.5V	CL0831-0008-6-00
1,000 pcs.	BF4-TX-14DS-0.5V(01)	CL0831-0008-6-01
2,000 pcs.	BF4-TX-14DS-0.5V(02)	CL0831-0008-6-02
10 pcs.	BF4-TX-14DS-0.5V(10)	CL0831-0008-6-10
100 pcs.	BF4-TX-14DS-0.5V(11)	CL0831-0008-6-11

NO.	MATERIAL	FINISH .	REMARKS	NO.	MATERIAL	FINISH .	REMARKS
3	Phosphor Bronze	3		6	PS		Black (Plastic reel)
2	Phosphor Bronze	2		5	Polyester		Clear (Cover tape)
1	LCP		UL94 V-0	4	PS		Clear (Embossed carrier tape)

UNITS	SCALE	COUNT	DESCRIPTION OF REVISIONS	DESIGNED	CHECKED	DATE
mm	10 : 1	1	DIS-K-003044	KS. JOKURA	SJ. SHIMIZU	13.08.23

APPROVED	DATE	DRAWING NO.
MT. SHIBUTANI	12.10.29	EDC3-178301-00
SJ. SHIMIZU	12.10.29	PART NO.
KS. JOKURA	12.10.26	BF4-TX-14DS-0.5V(**)
KS. JOKURA	12.10.26	CODE NO.

Dimensions of embossed carrier tape (Scale : FREE)

Packing reel (Scale : FREE)

Recommended reflow temperature profile using Lead-Free solder paste.

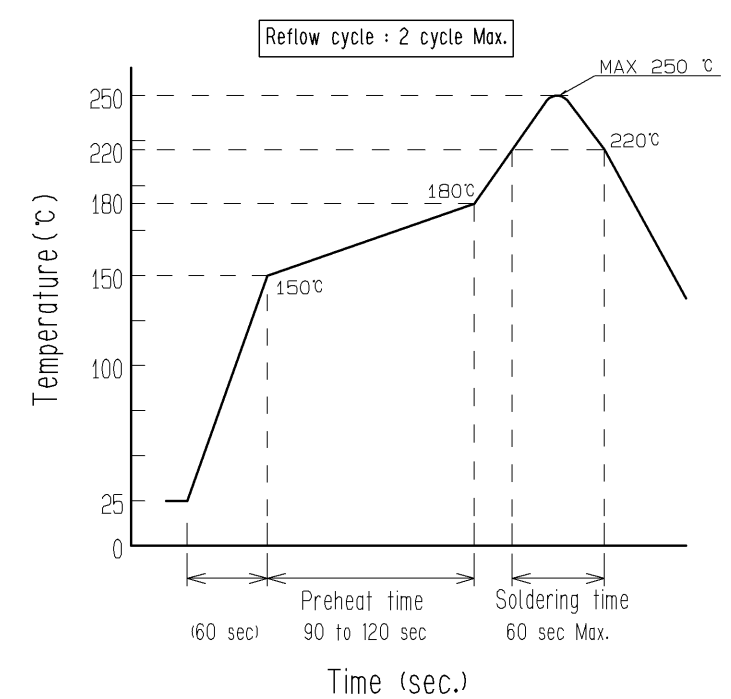
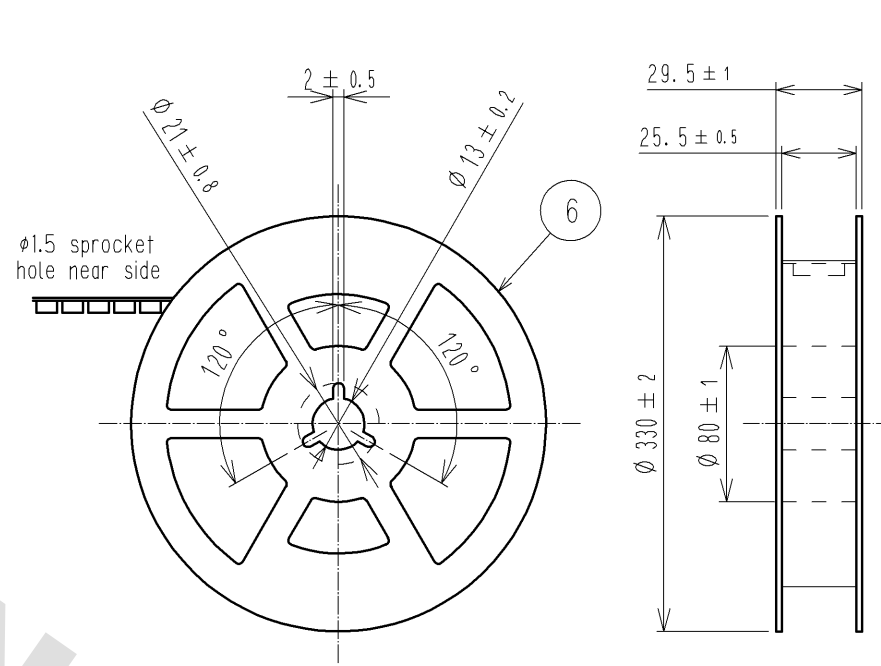
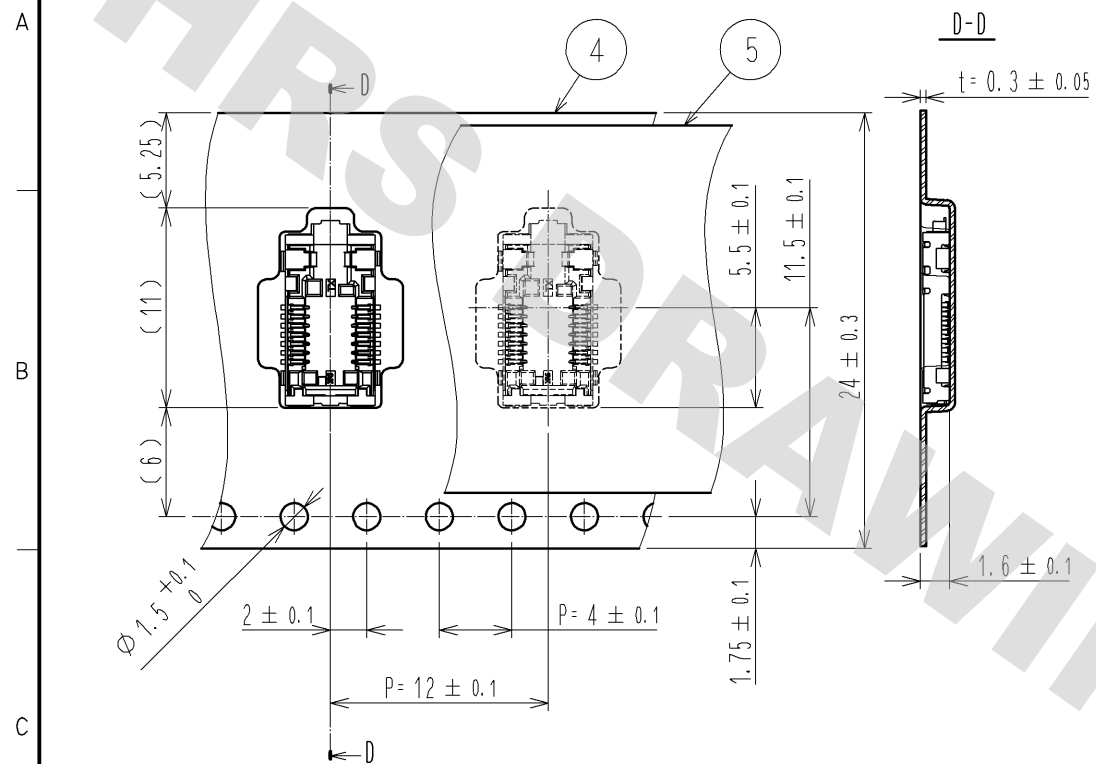

Taping direction (Scale : FREE)

Dimensions of engaged connector (Scale : FREE)

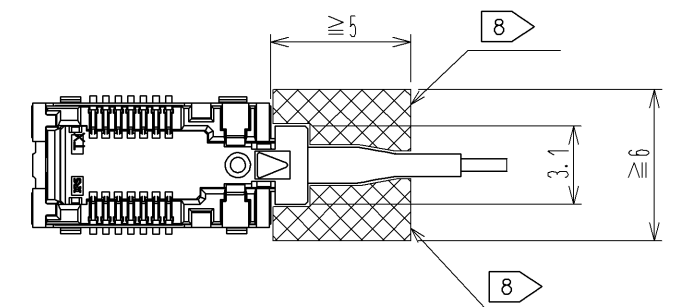
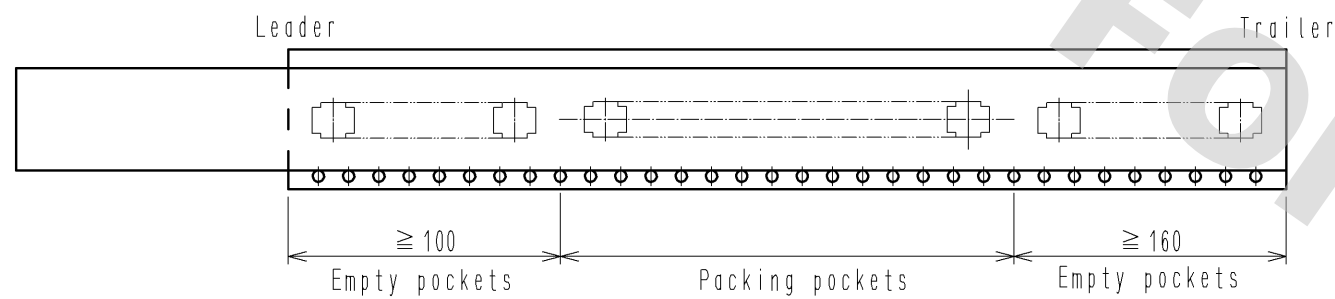

Recommended PCB land pattern

Recommended metal mask dimensions (Mask thickness : 120 μm)

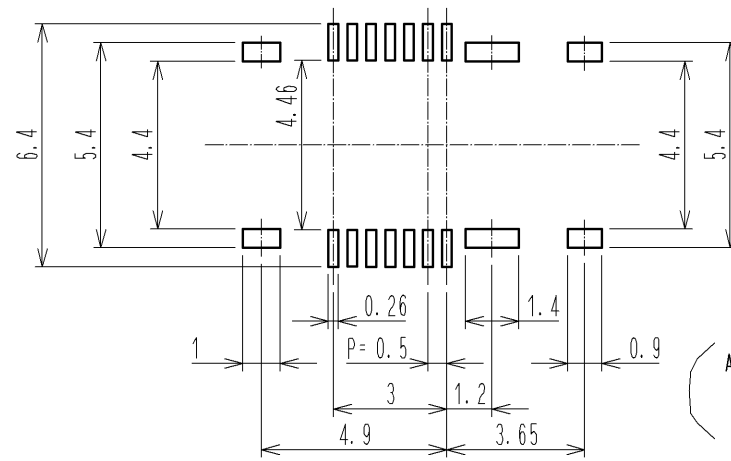
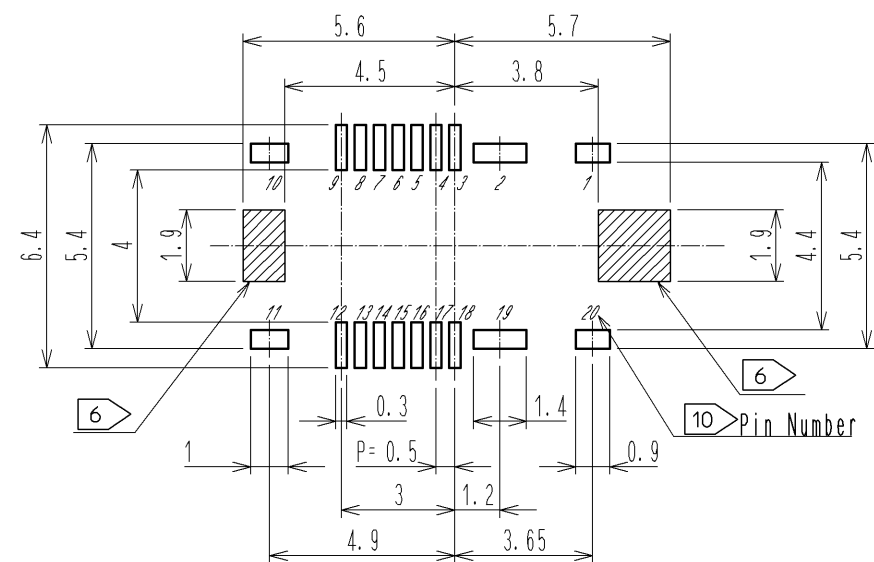

Aperture ratio
 Pads mounted contacts : 70%
 Pads mounted shell : 100%

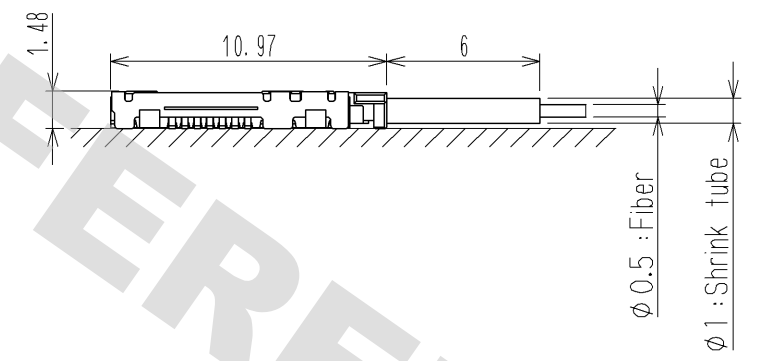

IRS	DRAWING NO.	EDC3-178301-00
	PART NO.	BF4-TX-14DS-0.5V(**)
	CODE NO.	
	NO.	

DRAWING FOR REFERENCE: This is subject to change without notice 12/05/2013