

NOTES

MATERIAL 20 GAUGE STEEL BASE AND TOP
 0.064" THICK ALUMINUM PANELS
 PARTS LIST EIGHT 6-32 NICKEL PLATED SCREWS (1421J6)
 FOUR SELF ADHESIVE RUBBER FEET (1421T3)
 FINISH OFF WHITE WITH 1 BLACK & 1 OFF WHITE PANEL
 (1426*-B) SATIN BLUE, 1 BLACK & 1 OFF WHITE PANEL

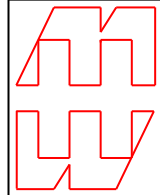
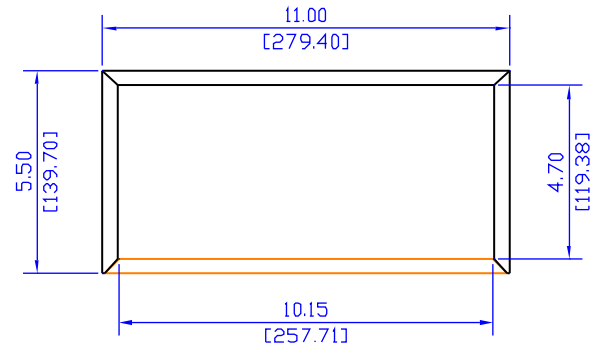
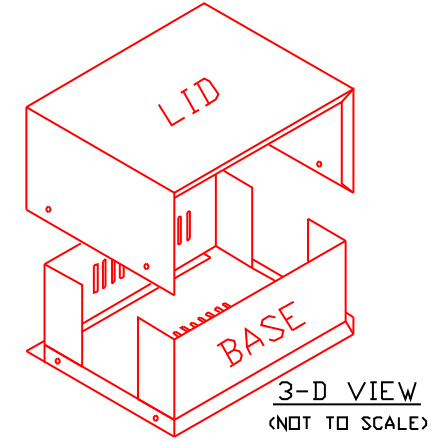
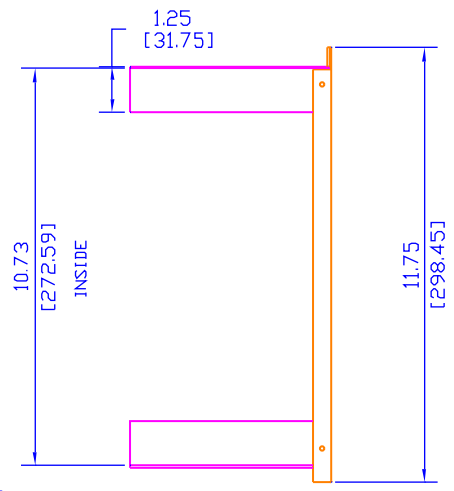
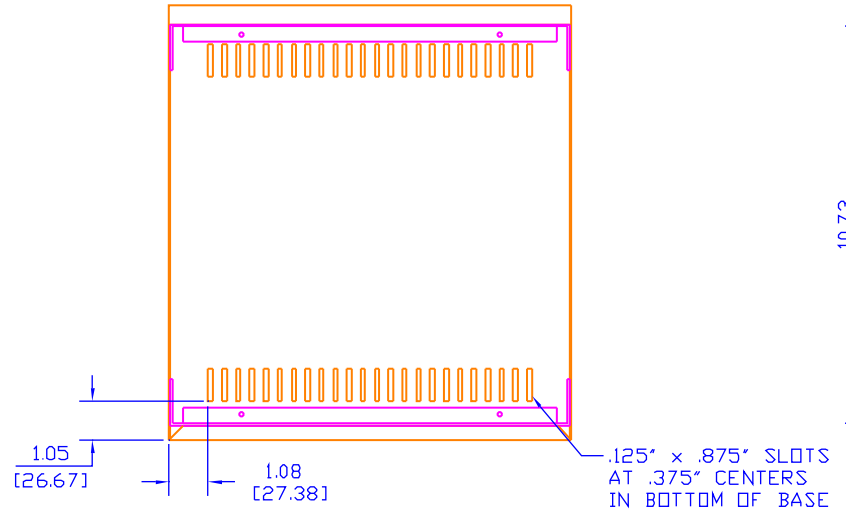
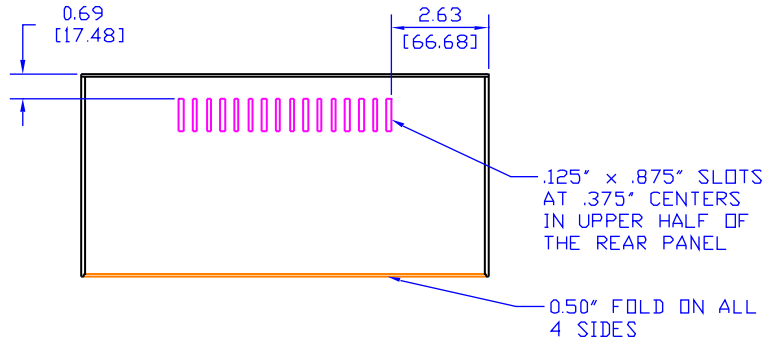

**HAMMOND
 MANUFACTURING**
 CANADA (519) 886 7171 FAX (519) 886 8311
 U.S.A. (716) 631 5700 FAX (716) 631 1156
 WEB: WWW.HAMMONDMFG.COM

UNLESS OTHERWISE SPECIFIED DIMENSIONS ARE IN INCHES .X +/- .1 .XX +/- .06 .XXX +/- .02 .XXXX +/- .005 HOLES +/- .005 ANGLES +/- 5 DEG.	DESCRIPTION	HAMMOND 1426 SERIES INSTRUMENT CASE	
	PART NUMBER	1426Q	DATE 12/23/99 PAGE 1 OF 1