

Extraction Tool 1976096-1

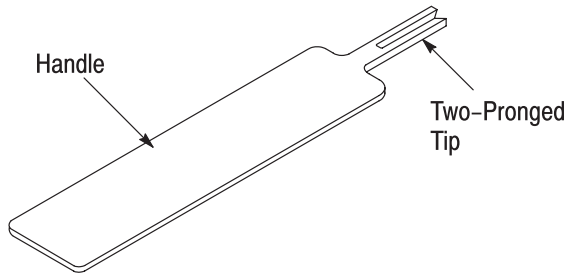

Figure 1

1. INTRODUCTION

Extraction Tool 1976096-1 is used to remove individual Generation III Timer Control Terminals from Timer Connectors (reference part number 521135-1).

Reasons for reissue of this instruction sheet are provided in Section 5, REVISION SUMMARY.

2. DESCRIPTION

The extraction tool is a handle with a two-pronged tip. See Figure 1. When inserted in the terminal cavity of the connector, the tip will depress the locking latch of the terminal. This will enable the terminal to be pulled out from the wire end of the connector.

3. USING THE TOOL

1. At the mating face of the connector, align the tip of the tool with the top of the terminal cavity of the terminal to be removed. See Figure 2.
2. Push the tip into the terminal cavity until it bottoms.
3. Holding the tool in place, gently pull the wire of the terminal until it is out of the connector.

NOTE



Terminals can be re-used if they are not deformed or damaged.

4. REPLACEMENT AND REPAIR

The extraction tool is not repairable. Order replacements through your representative, or call 1-800-526-5142, or send a facsimile of your purchase order to 717-986-7605, or write to:

CUSTOMER SERVICE (038-035)
 TYCO ELECTRONICS CORPORATION
 PO BOX 3608
 HARRISBURG PA 17105-3608

Using the Tool

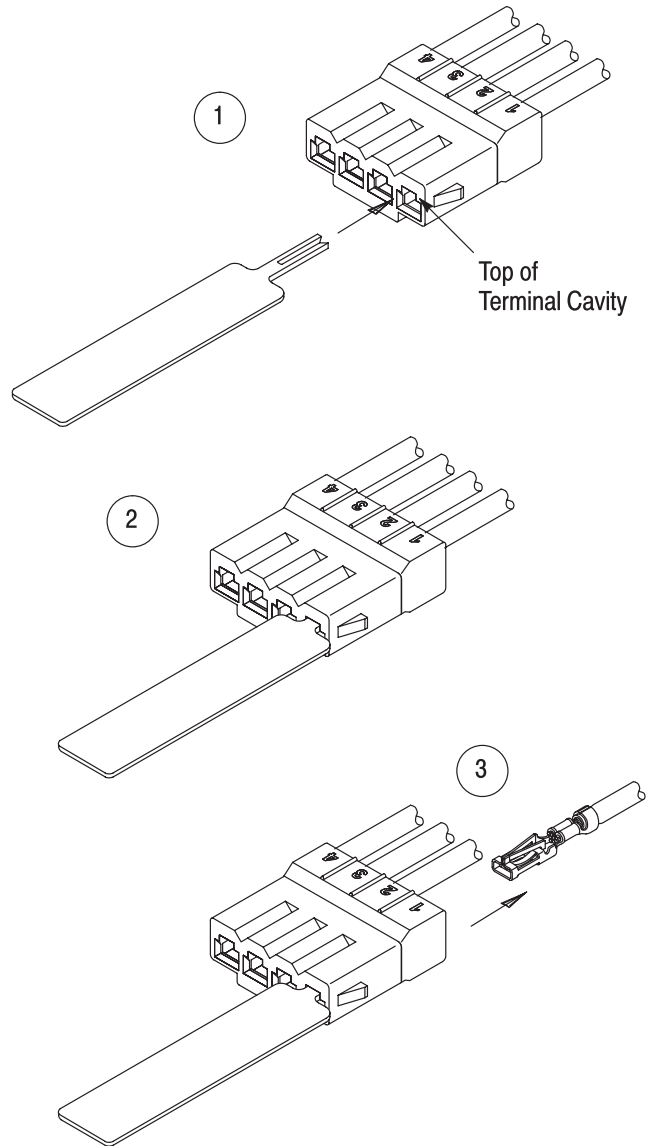

Figure 2

5. REVISION SUMMARY

Revisions to this instruction sheet include:

- Corrected Section 1 and Figure 2