

PART NUMBER	REV	FIRST USED
1385513-1	B	122500-1
1385513-2	B	565435-5
1385513-3	B	354500-1

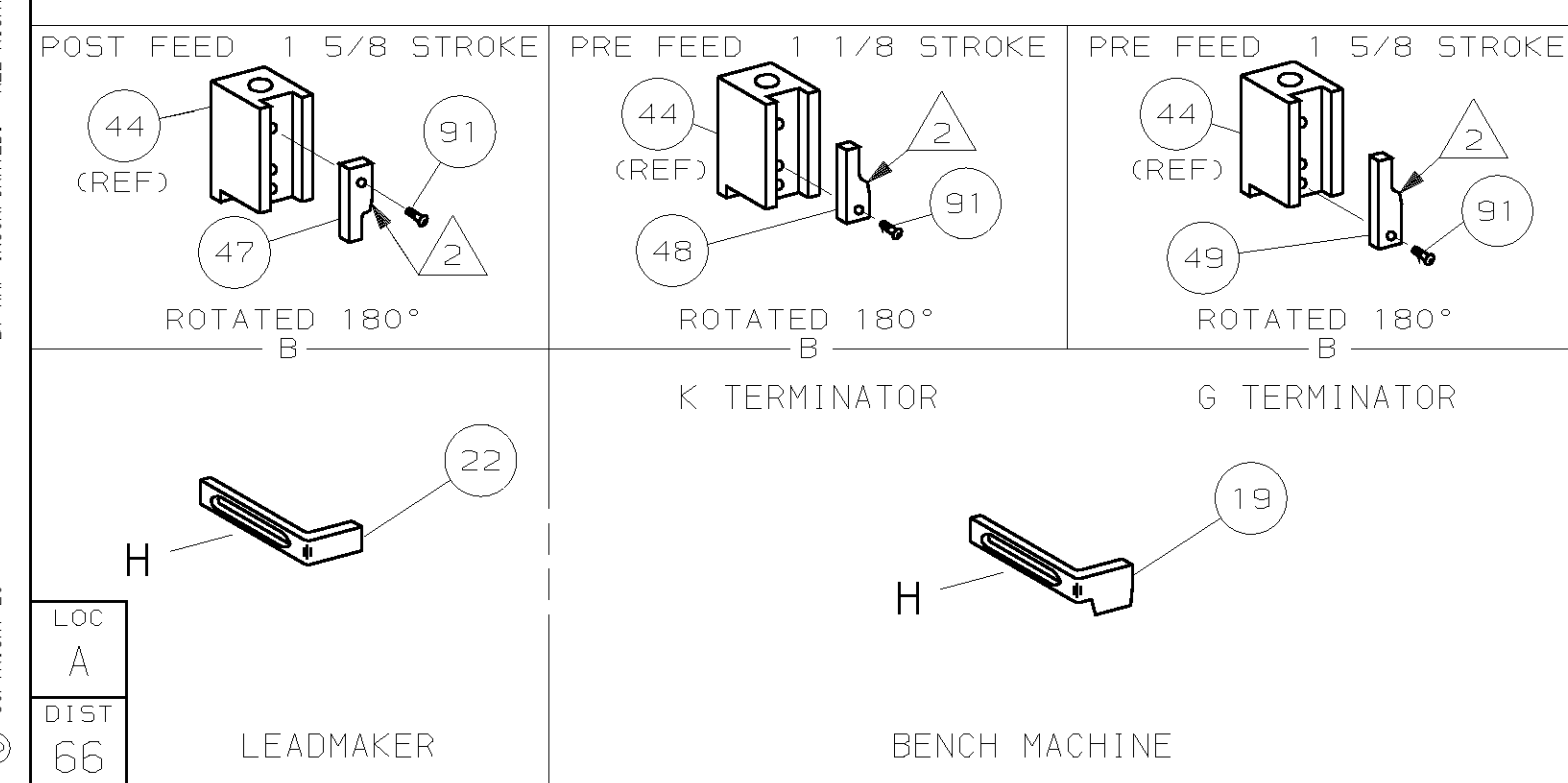
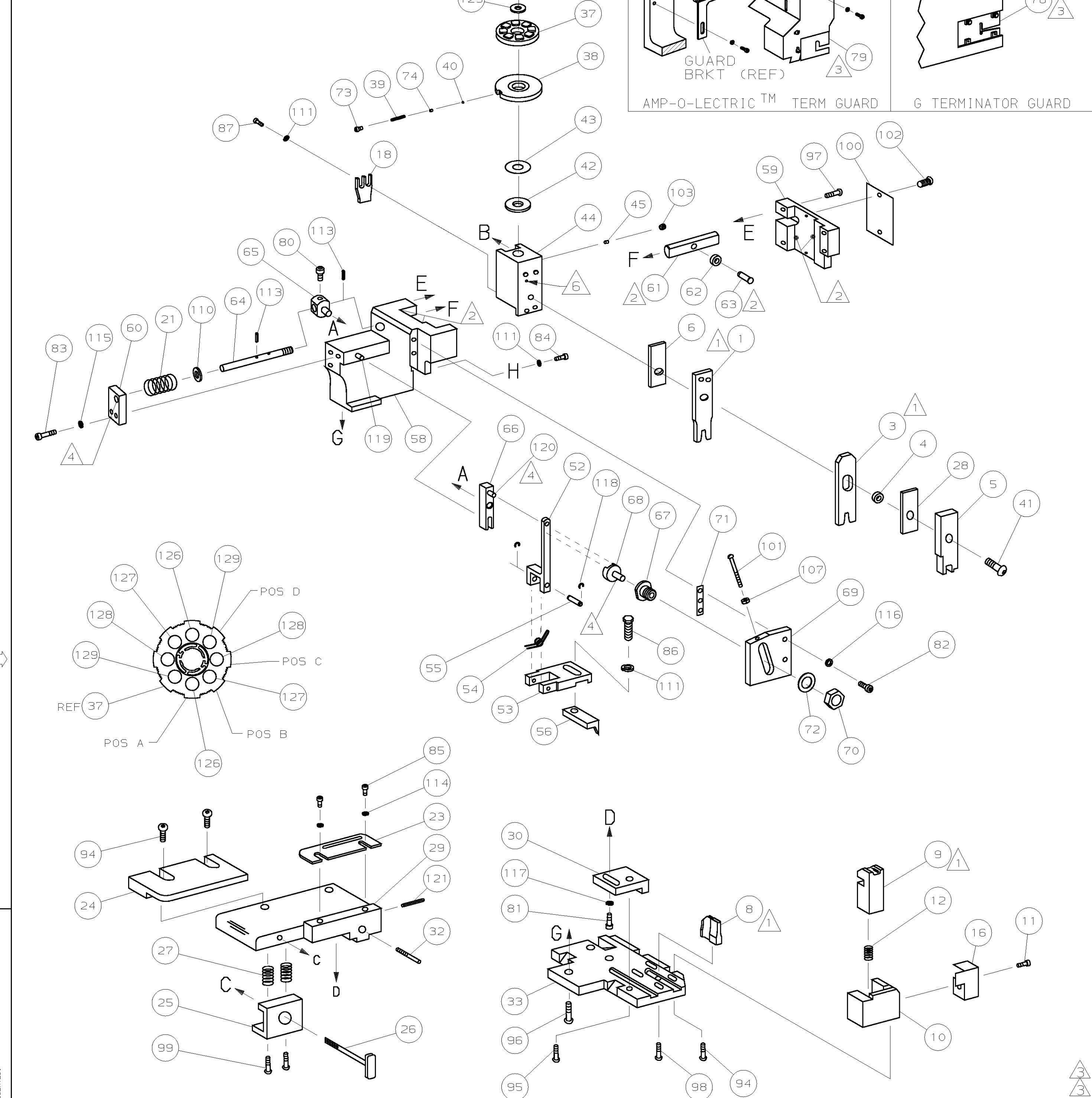

- 1 RECOMMENDED SPARE PARTS.
- 2 GREASE LIGHTLY.
- 3 GUARD MUST BE IN PLACE WHEN OPERATING APPLICATOR IN A BENCH MACHINE.
- 4 LUBRICATE DAILY USING NO. 20 MACHINE OIL.
- 5. ITEMS WITH QTY OF REF SPECIFIED (EXCEPT ITEMS 78 AND 79) ARE USED ON ITEM 46.
- 6 REMOVE SLOTTED SPRING PIN BEFORE PLACING ITEM 6 ON RAM.

TERMINAL NAME: 2.5 MM PITCH HPI CONTACT			
AMP TERMINAL		AMP CRIMP SPECS	
PAD LTR	CRIMP HEIGHT	WIRE SIZE	
A	.029 ±.002 [0.75 ±0.05mm]	22 OR 0.3mm <sup>2</sup>	
B	.027 ±.002 [0.70 ±0.05mm]	24 OR .22mm <sup>2</sup>	
C	.025 ±.002 [0.65 ±0.05mm]	26 OR .14mm <sup>2</sup>	
D	.024 ±.002 [0.625 ±0.025mm]	28 OR 0.08mm <sup>2</sup>	
CRIMP	SIZE	TYPE	RANGE
WIRE	.055 [1.40mm]	F	28-22 OR 0.08-0.3mm <sup>2</sup>
INSUL	.070 [1.78mm]	F	.039-.075

QTY	REF	REF	REF	U/M	DWG SIZE	PART NO	DESCRIPTION	ITEM NO
2	2	2	-	C		6-354779-3	PIN, WIRE DISC (.3305)D	129
2	2	2	-	C		6-354779-0	PIN, WIRE DISC (.3290)C	128
2	2	2	-	C		5-354779-6	PIN, WIRE DISC (.3270)B	127
2	2	2	-	C		5-354779-2	PIN, WIRE DISC (.3250)A	126
1	1	1	-	A		986950-1	WASHER, FLAT PRECISION	125
1	1	1	-	A		217238-1	GENERAL INSTRUCTION PACKAGE	124
1	1	1	-	-		4088040	SF APPL INST 408-8040	123
								122
1	1	1	-	A		4-21028-0	PIN, SLT SPR (ø.093x.75)ST GDE PL	121
REF	REF	REF	-	A		1-21030-1	PIN, DOWEL (ø.187x.50)LEVER	120
REF	REF	REF	-	A		1-21030-6	PIN, DOWEL (ø.187x1.25)HOUSING	119
REF	REF	REF	-	A		21045-3	RING, RET "C" (ø.187)FD FING PIN	118
1	1	1	-	A		21024-5	WASHER, LOCK (#10)ADJ BLK	117
REF	REF	REF	-	A		21024-5	WASHER, LOCK (#10)ADJ PLATE	116
REF	REF	REF	-	A		21024-5	WASHER, LOCK (#10)FEED GDE ROD	115
2	2	2	-	A		21024-2	WASHER, LOCK (#4)FRONT STP GUIDE	114
REF	REF	REF	-	A		5-21028-1	PIN, SLT SPR (ø.125x.50)ADJ ROD	113
								112
4	4	4	-	A		21024-4	WASHER, LOCK (#8) STRIPPER	111
REF	REF	REF	-	A		21899-4	WASHER, FLAT (ø5/16) SCREW ADJ	110
								109
								108
REF	REF	REF	-	A		21068-5	NUT, HEX (6-32)FEED ADJ	107
								106
								105
								104
1	1	1	-	A		21009-2	SCR, SKT 5ET (1/4-20x.25 LW)RAM	103
2	2	2	-	A		21017-2	SCR, DRIVE (#2x.19) ID PLATE	102
REF	REF	REF	-	A		6-23715-5	SCR, PAN HD (6-32x1.50)FEED ADJ	101
1	1	1	-	B		461264-1	PLATE, IDENTIFICATION	100
2	2	2	-	A		3-21002-0	SCR, BHC (10-32x.88)DRAG	99
1	1	1	-	A		22733-8	SCR, BHC (8-32x.38 LW)ANVIL	98
REF	REF	REF	-	A		2-21002-9	SCR, BHC (10-32x.75)CAP	97
REF	REF	REF	-	A		2-22733-8	SCR, BHC (1/4-20x.62)HOUSING	96
REF	REF	REF	-	A		2-21002-7	SCR, BHC (10-32x.50)56 ADJ BLOCK	95
4	4	4	-	A		2-21002-2	SCR, BHC (8-32x.50)TERM H DWN	94
								93
								92
1	1	1	-	A		1-21002-7	SCR, BHC (6-32x.38)CAM	91
								90
								89
								88
2	2	2	-	A		2-21000-5	SCR, SHC (8-32x.25)DEP-HOLD	87
1	1	1	-	A		2-22603-0	SCR, HEX HD (8-32x.31)FEED FINGER	86
2	2	2	-	A		1-21000-3	SCR, SHC (4-40x.25)FR ST GUIDE	85
1	1	1	-	A		2-21000-7	SCR, SHC (8-32x.50)STRIPPER	84
REF	REF	REF	-	A		3-21000-7	SCR, SHC (10-32x.75)FEED ROD GD	83
REF	REF	REF	-	A		3-21000-6	SCR, SHC (10-32x.62)FD ADJ BLK	82
1	1	1	-	A		3-21000-4	SCR, SHC (10-32x.38)56 ADJ BL	81
REF	REF	REF	-	A		3-21000-4	SCR, SHC (10-32x.38)PIVOT BLK	80
-	REF	-	-	B		455749-1	GUARD, WINDOW	79
REF	-	-	-	B		679532-1	INSERT, GUARD	78
								77
								76
								75
1	1	1	-	A		690603-1	SPRING, ASSIST	74
1	1	1	-	A		23030-1	SCR, SHC (6-32x.25 SL)INS DISC	73
REF	REF	REF	-	A		458109-1	WASHER, SPECIAL	72
REF	REF	REF	-	A		690517-1	SPACER	71
								70
								69
								68
								67
								66
								65
								64
								63
								62
								61
								60
								59
								58
								57
								56
								55
								54
								53
								52
								51
								50
								49
								48
								47
								46
								45
								44
								43
								42
								41
								40
								39
								38
								37
								36
								35
								34
								33
								32
								31
								30
								29
								28
								27
								26
								25
								24
								23
								22
								21
								20
								19
								18
								17
								16
								15
								14
								13
								12
								11
								10
								9
								8
								7
								6
								5
								4
								3
								2
								1

QTY	REF	REF	REF	U/M	DWG SIZE	PART NO	DESCRIPTION	ITEM NO
-1							LEADMAKER	
-2							BENCH MODEL K	
-3							BENCH MODEL G	
	REF	REF	REF	-	B	22594-8	NUT, HEX (1/2-20)	70
	REF	REF	REF	-	B	240628-1	PLATE, ADJUSTMENT	69
	REF	REF	REF	-	B	240626-1	SHAFT, PIVOT	68
	REF	REF	REF	-	B	240633-1	BUSHING	67
	REF	REF	REF	-	A	455680-1	LEVER, INTERMEDIATE	66
	REF	REF	REF	-	B	240629-1	BLOCK, PIVOT	65
	REF	REF	REF	-	A	240632-2	SCREW, ADJ FEED ROD	64
	REF	REF	REF	-	B	240659-3	PIN, CAM ROLLER	63
	REF	REF	REF	-	B	240658-1	ROLLER, CAM	62
	REF	REF	REF	-	B	454398-2	ROD, FEED	61
	REF	REF	REF	-	A	454178-1	GUIDE, FEED ROD	60
	REF	REF	REF	-	C	454220-1	CAP, RAM	59
	REF	REF	REF	-	D	454485-1	HOUSING	58
								57
								56
	1	1	1	-	B	690542-2	PAWL, FEED	55
	REF	REF	REF	-	B	240624-1	PIN, FEED FINGER	54
	REF	REF	REF	-	B	691499-1	SPRING, FEED FINGER	53
	REF	REF	REF	-	B	690541-1	HOLDER, FEED FINGER	52
	REF	REF	REF	-	A	455679-1	LEVER, TERMINAL FEED ARM	51
								50
	1	-	-	-	B	690602-6	CAM, PRE-FEED 1 5/8 ST	49
	-	1	-	-	B	690602-5	CAM, PRE-FEED 1 1/8 ST	48
	-	-	1	-	B	690501-4	CAM, POST-FEED 1 5/8 ST	47
	1	1	1	-	B	459456-1	APPLICATOR, BASIC (SUBASSY)	46
	1	1	1	-	A	690191-1	PLUG, NYLON	45
	1	1	1	-	C	1-455673-1	RAM	

# Mouser Electronics

Authorized Distributor

Click to View Pricing, Inventory, Delivery & Lifecycle Information:

[TE Connectivity:](#)

[1385513-3](#)