

PART NUMBER	REV	FIRST USED	POWER UNIT	FEED TYPE	DESCRIPTION
1852336-1	A	122500-1	LEADMAKER	POST FEED	CUTS CARRIER
1852336-2	A	565435-5	BENCH MODEL K	PRE FEED	CUTS CARRIER
1852336-3	A	354500-1	BENCH MODEL G	PRE FEED	CUTS CARRIER
1852336-6	A	122500-1	LEADMAKER	POST FEED	CONTINUOUS CARRIER
7-1852336-7	A	-	-	-	SPARE PARTS



TERMINAL NAME: AMPMODU 2mm PIN				
SOCKET	PIN	AMP TERMINAL - AMP CRIMP SPECS		
-	1740438-2			
		PAD LTR	CRIMP HEIGHT	WIRE SIZE
-	-	A	0.74±0.05mm[.029±.002]	24AWG
-	-	B	0.69±0.05mm[.027±.002]	26AWG
-	-	C	0.64±0.05mm[.025±.002]	28AWG
-	-	D	-	-
		CRIMP	SIZE	TYPE
-	-	WIRE	1.07mm[.042]	F
-	-	INSUL	1.40mm[.055]	F
		FEED	APPLICATOR INSTRUCTIONS	SET UP GAGE
WIRE STRIP LENGTH	TERM APPL SPEC	1.6 - 1.8mm	114-18172	4.0mm
			408-8040	458637-1

LOC	DIST	REV	DESCRIPTION	DATE	DRN	APPR
A	66		RELEASED	16OCT2006	RK	GB

- △ RECOMMENDED SPARE PARTS
- △ GREASE LIGHTLY
- △ GUARD MUST BE IN PLACE WHEN OPERATING APPLICATOR IN A BENCH MACHINE

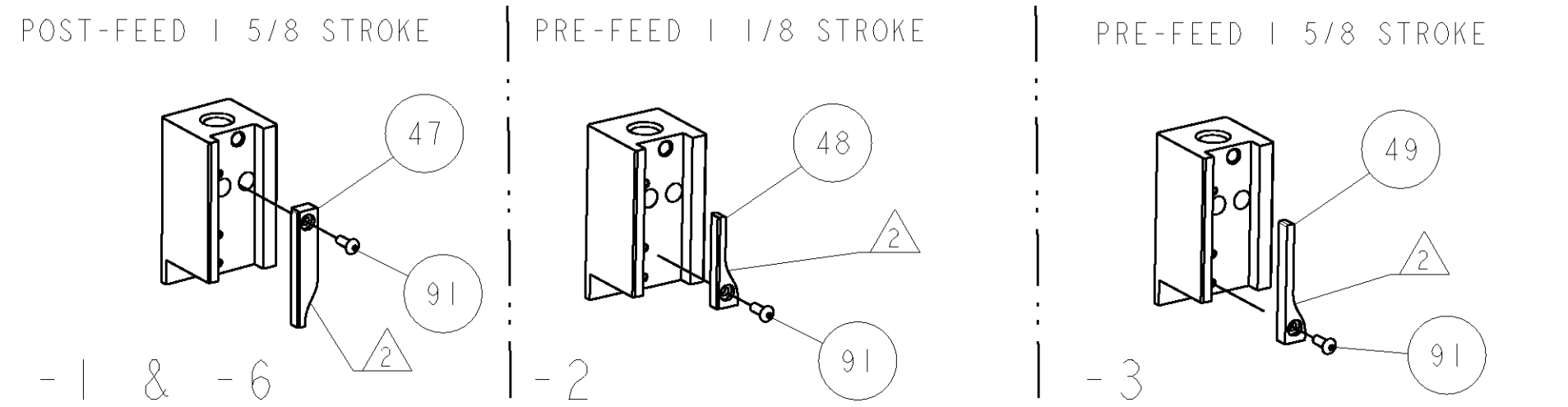
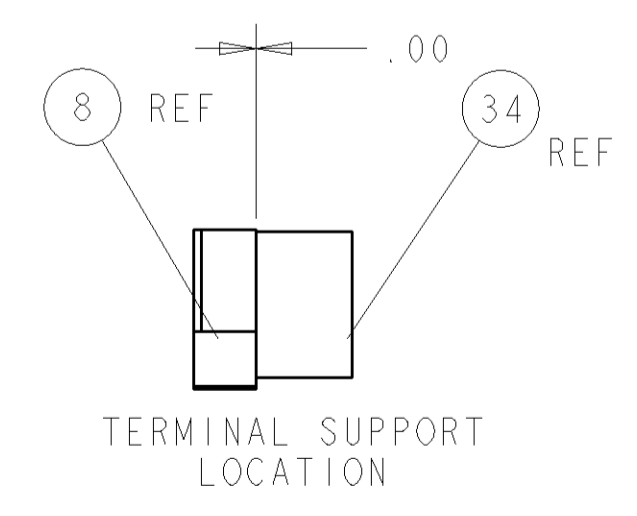
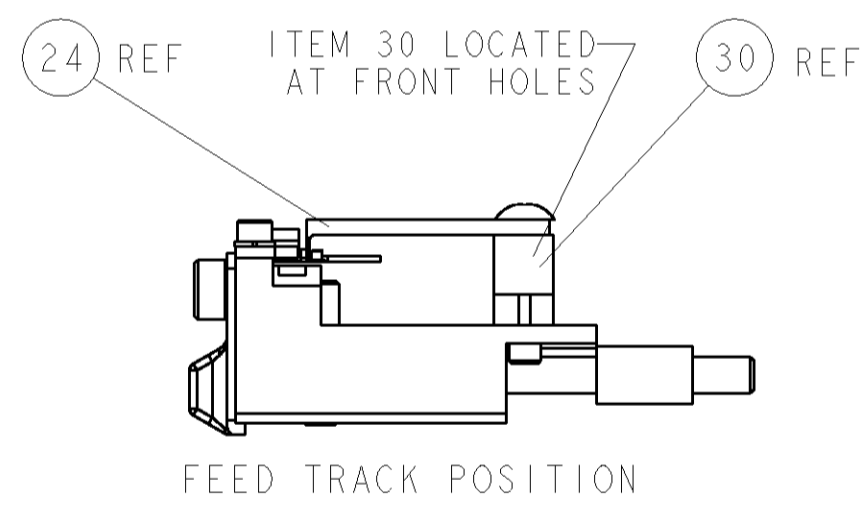
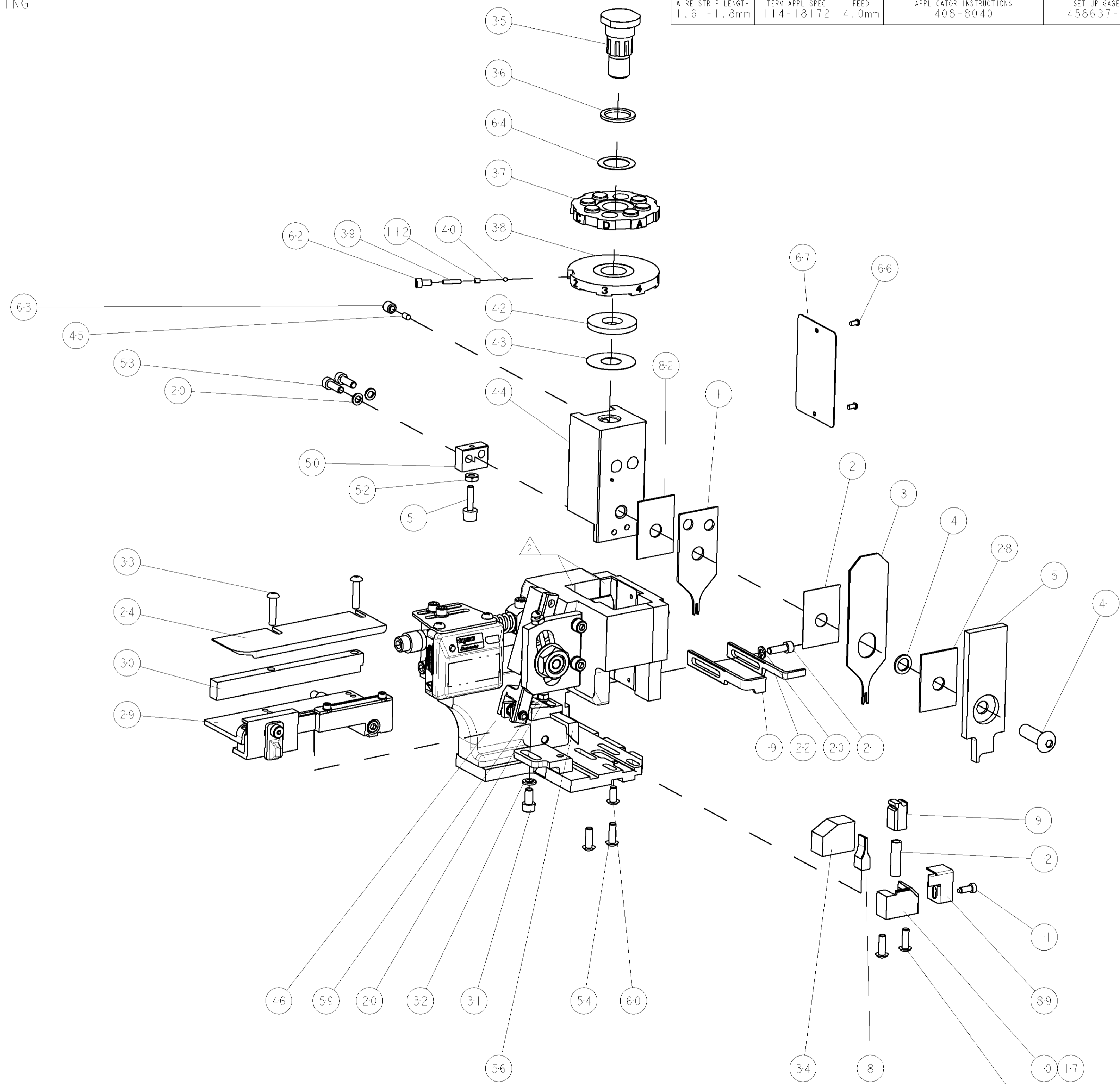
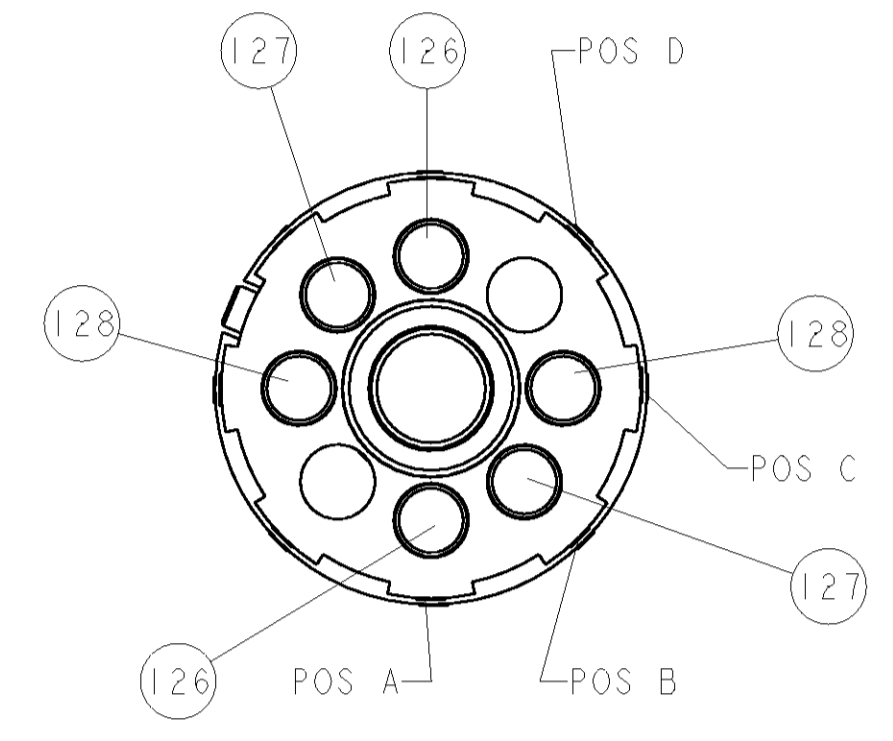

-	2	2	2	2	-	2-354779-1	PIN, WIRE DISC, .3095	128
-	2	2	2	2	-	1-354779-7	PIN, WIRE DISC, .3075	127
-	2	2	2	2	-	1-354779-3	PIN, WIRE DISC, .3055	126
△	-	-	-	REF	-	455749-1	GUARD WINDOW	116
△	-	-	-	REF	-	679532-1	INSERT, GUARD	115
-	1	1	1	1	-	690603-1	SPRING ASSIST AMP-O-MATOR APPLICATOR	112
-	1	1	1	1	-	1-21002-7	SCR, BTN SKT HD CAP 6-32 X .375	91
-	1	1	1	1	-	318563-1	GUARD, FRONT CHIP	89
-	1	1	1	1	-	455888-9	SPACER, CRIMPER	82
-	1	1	1	1	-	4088040	SF APPL INST 408-8040	72
-	1	1	1	1	-	217238-1	GENERAL INSTRUCTION PKG	71
-	1	1	1	1	-	461264-1	PLATE, IDENTIFICATION	67
-	2	2	2	2	-	21017-2	SCREW, DRIVE	66
-	1	1	1	1	-	986950-1	WASHER, FLAT PRECISION	64
-	1	1	1	1	-	21009-2	SCR, SET, SELF LOCKING 1/4-20 X .250	63
-	1	1	1	1	-	23030-1	SCR, SKT HD CAP 6-32 X .25	62
-	1	1	1	1	-	22733-8	SCR, BHSC, SELF-LOCKING, 8-32 X .375	60
-	1	1	1	1	-	2-22603-0	SCR, HEX HD CAP 8-32 X .312	59
-	1	1	1	1	-	458537-2	PAWL, FEED	56
-	4	4	4	4	-	2-21002-2	SCR, BTN SKT HD CAP 8-32 X .500	54
-	2	2	2	2	-	2-21000-7	SCR, SKT HD CAP 8-32 X .500	53
-	1	1	1	1	-	21018-5	NUT, HEX, REG 6-32	52
-	1	1	1	1	-	811242-2	BUMPER, HOLD DOWN	51
-	1	1	1	1	-	690753-1	SPACER, TONKER	50
-	-	-	-	-	..	690602-6	CAM, PRE FEED, 1/8	49
-	-	-	-	-	..	690602-5	CAM, PRE FEED, 1/8	48
-	1	-	-	-	-	690501-4	CAM, POST FEED, 1/8	47
-	1	1	1	1	-	459456-1	APPL. BASIC SUB ASSY (SIDE WISE MOCA)	46
-	1	1	1	1	-	690191-1	PLUG, NYLON	45
-	1	1	1	1	-	455673-1	RAM, SIDE FEED	44
-	1	1	1	1	-	690125-1	SHIM SUB-ASSY	43
-	1	1	1	1	-	690124-4	WASHER, RAM (.135)	42
-	1	1	1	1	-	7-21002-9	SCR, BTN SKT HD CAP 5/16-24 X 1.00	41
-	1	1	1	1	-	23241-6	BALL, STEEL	40
-	1	1	1	1	-	690170-1	SPRING, COMPRESSION	39
-	1	1	1	1	-	690142-5	DISC, INSULATION	38
-	1	1	1	1	-	354777-1	WIRE DISC, ASSEMBLY	37
-	1	1	1	1	-	22480-5	SPRING, COMPRESSION	36
-	1	1	1	1	-	690212-1	POST, RAM	35
-	1	1	1	1	-	690786-3	TERMINAL SUPPORT	34
-	2	2	2	2	-	2-21002-4	SCR, BTN SKT HD CAP 8-32 X .750	33
-	1	1	1	1	-	21024-5	WASHER, SPRG LOCK, REG NO 10	32
-	1	1	1	1	-	3-21000-4	SCR, SKT HD CAP 10-32 X .375	31
-	1	1	1	1	-	1320908-4	SPACER, STRIP GUIDE	30
-	1	1	1	1	-	1633091-1	ASSEMBLY, STRIP GUIDE	29
-	1	1	1	1	-	1-455888-0	SPACER, CRIMPER	28
-	1	1	1	1	-	1320928-1	PLATE, STRIP GUIDE	24
-	1	-	-	-	-	690472-2	STRIPPER	22
-	1	1	1	1	-	2-21000-7	SCR, SKT HD CAP 8-32 X .500	21
-	4	4	4	4	-	21024-4	WASHER, SPRG LOCK, REG NO 8	20
-	-	-	-	-	-	691353-1	STRIPPER	19
△	-	-	-	-	-	679625-1	SHEAR HOLDER, FRONT (NO CUT)	17
-	1	1	1	1	-	3-22280-3	SPRING, COMPRESSION	12
-	1	1	1	1	-	690461-1	STOP, SHEAR	11
△	-	-	-	-	-	690459-1	SHEAR HOLDER, FRONT	10
△	1	1	1	1	-	462006-1	FLOATING SHEAR, FRONT	9
△	1	1	1	1	-	3-904717-2	ANVIL, COMBINATION	8
-	1	1	1	1	-	2-455889-0	DEPRESSOR, SHEAR	5
-	1	1	1	1	-	3-238011-7	BLOCK, CRIMPER SPACER	4
△	1	1	1	1	-	4-1424909-3	CRIMPER, INSULATION F	3
△	1	1	1	1	-	455888-3	SPACER, CRIMPER	2
△	1	1	1	1	-	3-456401-6	CRIMPER, WIRE PREMIUM	1

ITEM NO	PART NO	DESCRIPTION	ITEM NO
-77	-6	-3	-2
-1	U/M		

DIMENSIONS: INCHES 	TOLERANCES UNLESS OTHERWISE SPECIFIED: 0 PLC ±.01 1 PLC ±.01 2 PLC ±.01 3 PLC ±.001 4 PLC ±.001 ANGLES ±.001	DWG: R. KNEPPER 21SEP2006 CHK: G. BALLEY 16OCT2006 APD: J. BENCHOFF 16OCT2006 NAME: SIDE FEED HDM APPLICATOR PRODUCT SPEC: - APPLICATION SPEC: - MATERIAL: - FINISH: - WEIGHT: - CUSTOMER DRAWING: -	tyco Tyco Electronics Harrisburg, PA 17105-3608 SIZE: A1 CAGE CODE: 00779 DRAWING NO: C=1852336 SCALE: 3:5 SHEET: 1 OF 1 REV: A
---------------------------	--	---	--

CUSTOMER VIEWABLE ASSEMBLY

Mouser Electronics

Authorized Distributor

Click to View Pricing, Inventory, Delivery & Lifecycle Information:

[TE Connectivity:](#)

[1852336-2](#)