

# Analog Devices Welcomes Hittite Microwave Corporation

NO CONTENT ON THE ATTACHED DOCUMENT HAS CHANGED



**THIS PAGE INTENTIONALLY LEFT BLANK**



## SMT PHEMT MEDIUM POWER AMPLIFIER 21 - 32 GHz

### Typical Applications

The HMC499LC4 is ideal for:

- Point-to-Point Radios
- Point-to-Multi-Point Radios & VSAT
- Test Equipment & Sensors
- Military End-Use

### Features

- Output IP3: +34 dBm
- Saturated Power: +24 dBm @ 16% PAE
- Gain: 17 dB
- Supply: +5V @ 200mA
- 50 Ohm Matched Input/Output
- RoHS Compliant 4x4 mm SMT Package

### Functional Diagram

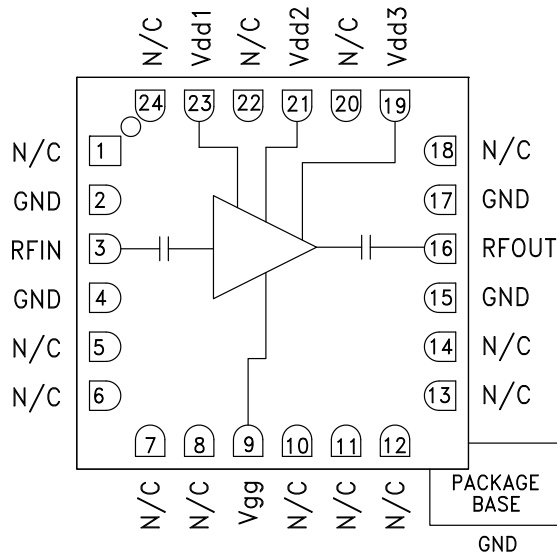

### General Description

The HMC499LC4 is a high dynamic range GaAs PHEMT MMIC Medium Power Amplifier housed in a leadless "Pb free" RoHS Compliant SMT package. Operating from 21 to 32 GHz, the amplifier provides 16 dB of gain, +24 dBm of saturated power and 16% PAE from a +5V supply voltage. The RF I/Os are DC blocked and matched to 50 Ohms for ease of use. The HMC499LC4 eliminates the need for wire bonding, allowing use of surface mount manufacturing techniques.

### Electrical Specifications, $T_A = +25^\circ C$ , $V_{dd1, 2, 3} = 5V$ , $I_{dd} = 200 mA^*$

Parameter	Min.	Typ.	Max.	Min.	Typ.	Max.	Min.	Typ.	Max.	Units
Frequency Range	21 - 24			24 - 28			28 - 32			GHz
Gain	14	17		13	16		9	13		dB
Gain Variation Over Temperature		0.02	0.03		0.02	0.03		0.02	0.03	dB/ °C
Input Return Loss		10			8			8		dB
Output Return Loss		11			12			8		dB
Output Power for 1 dB Compression (P1dB)	20	23		20	23		20	23		dBm
Saturated Output Power (Psat)		23.5			23.5			24		dBm
Output Third Order Intercept (IP3)		31			34			33.5		dBm
Noise Figure		6			5			5		dB
Supply Current (I <sub>dd</sub> )(V <sub>dd</sub> = +5V, V <sub>gg</sub> = -0.8V Typ.)		200			200			200		mA

\* Adjust V<sub>gg</sub> between -2 to 0V to achieve I<sub>dd</sub> = 200 mA typical.

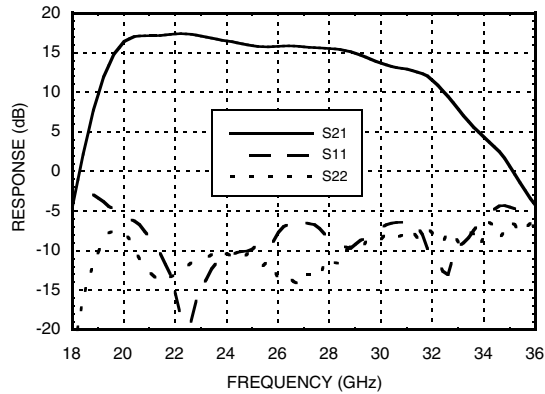
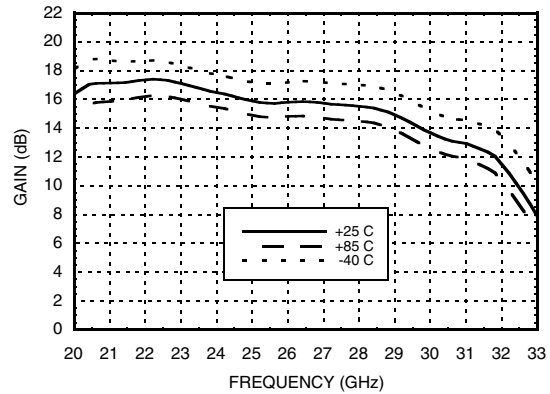
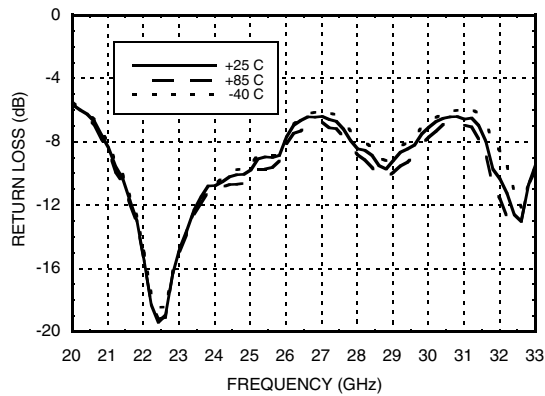
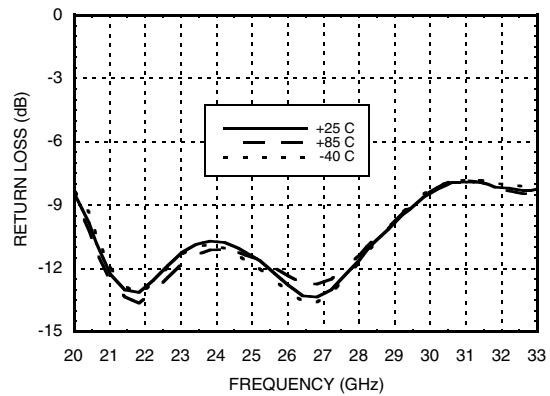
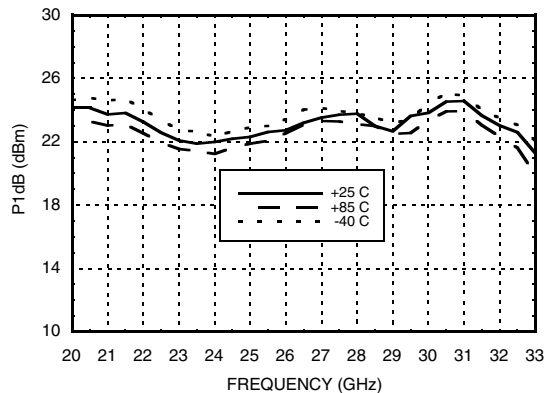
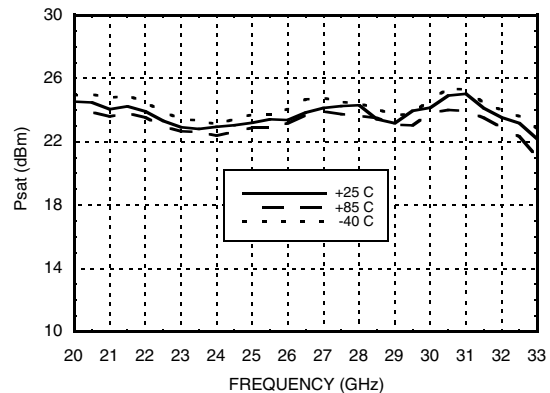
**SMT PHEMT MEDIUM POWER AMPLIFIER  
21 - 32 GHz**
**Broadband Gain & Return Loss**

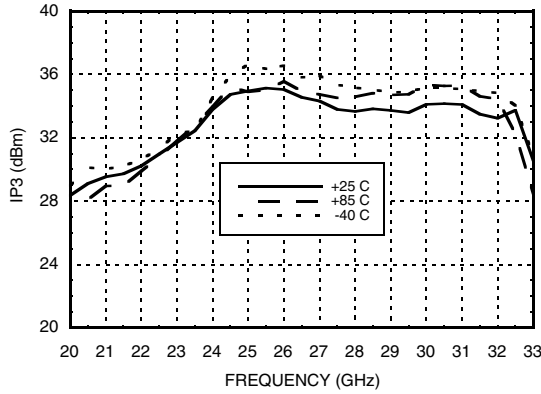
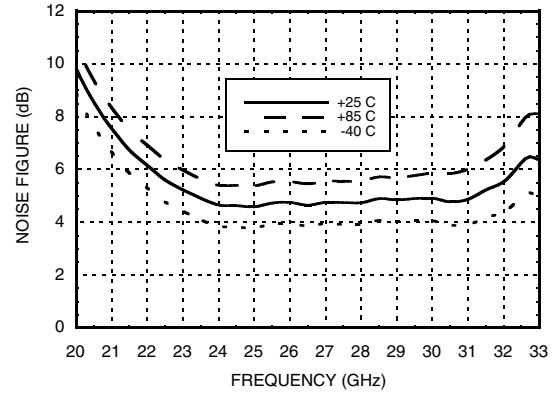
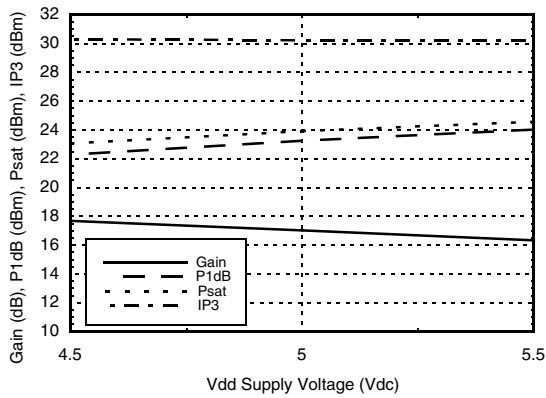
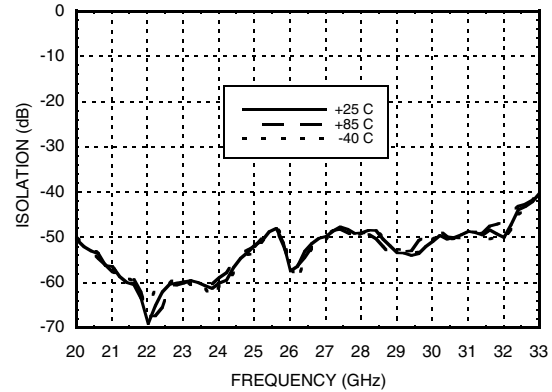
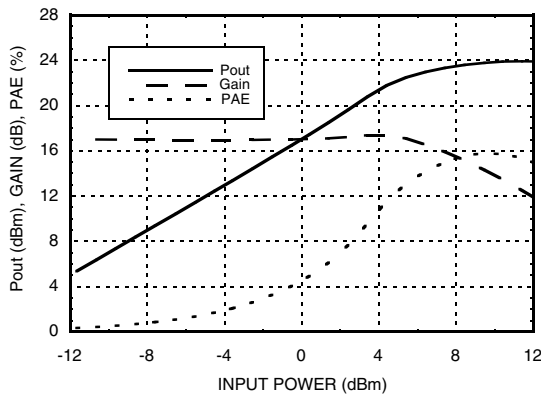
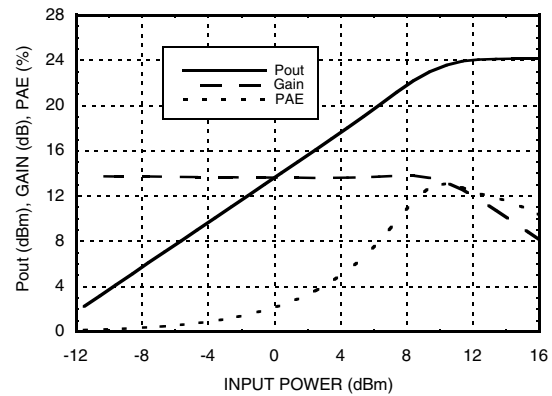
**Gain vs. Temperature**

**Input Return Loss vs. Temperature**

**Output Return Loss vs. Temperature**

**P1dB vs. Temperature**

**Psat vs. Temperature**

**SMT PHEMT MEDIUM POWER AMPLIFIER  
21 - 32 GHz**
**Output IP3 vs. Temperature**

**Noise Figure vs. Temperature**

**Gain, Power & Output IP3  
vs. Supply Voltage @ 22 GHz**

**Reverse Isolation vs. Temperature**

**Power Compression @ 22 GHz**

**Power Compression @ 30 GHz**

## SMT PHEMT MEDIUM POWER AMPLIFIER 21 - 32 GHz

### Absolute Maximum Ratings

Drain Bias Voltage (Vdd1, Vdd2, Vdd3)	+5.5 Vdc
Gate Bias Voltage (Vgg)	-4 to 0 Vdc
RF Input Power (RFIN)(Vdd = +5 Vdc)	+20 dBm
Channel Temperature	175 °C
Continuous Pdiss (T= 85 °C) (derate 25 mW/°C above 85 °C)	2.25 W
Thermal Resistance (channel to ground paddle)	40 °C/W
Storage Temperature	-65 to +150 °C
Operating Temperature	-40 to +85 °C

### Typical Supply Current vs. Vdd

Vdd (Vdc)	Idd (mA)
+4.5	193
+5.0	200
+5.5	207

Note: Amplifier will operate over full voltage ranges shown above. Vgg adjusted to achieve Idd= 200 mA at +5V.



ELECTROSTATIC SENSITIVE DEVICE  
OBSERVE HANDLING PRECAUTIONS

### Outline Drawing

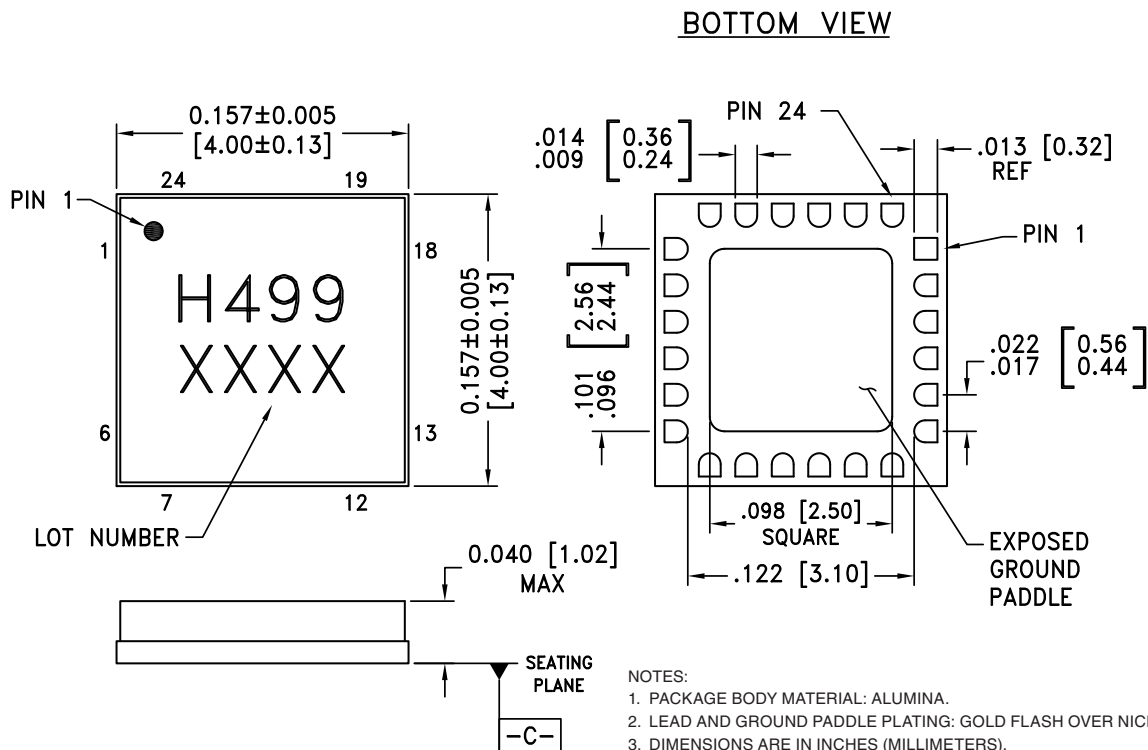

- NOTES:
1. PACKAGE BODY MATERIAL: ALUMINA.
  2. LEAD AND GROUND PADDLE PLATING: GOLD FLASH OVER NICKEL.
  3. DIMENSIONS ARE IN INCHES (MILLIMETERS).
  4. LEAD SPACING TOLERANCE IS NON-CUMULATIVE.
  5. PACKAGE WARP SHALL NOT EXCEED 0.05MM DATUM  $\square-C$
  6. ALL GROUND LEADS AND GROUND PADDLE MUST BE SOLDERED TO PCB RF GROUND.

### Package Information

Part Number	Package Body Material	Lead Finish	MSL Rating	Package Marking <sup>[2]</sup>
HMC499LC4	Alumina, White	Gold over Nickel	MSL3 <sup>[1]</sup>	H499 XXXX

[1] Max peak reflow temperature of 260 °C

[2] 4-Digit lot number XXXX



## SMT PHEMT MEDIUM POWER AMPLIFIER 21 - 32 GHz

### Pin Descriptions

Pin Number	Function	Description	Interface Schematic
1, 5 - 8, 10 - 14, 18, 20, 22, 24	N/C	No connection required. These pins may be connected to RF/DC ground without affecting performance.	
2, 4, 15, 17	GND	Package bottom has an exposed metal paddle that must also be connected to RF/DC ground.	
3	RFIN	This pin is AC coupled and matched to 50 Ohms.	
9	Vgg	Gate control for amplifier. Adjust to achieve Id of 200 mA. Please follow "MMIC Amplifier Biasing Procedure" Application Note. External bypass capacitors of 100 pF, 1000 pF and 2.2 μF are required.	
16	RFOUT	This pad is AC coupled and matched to 50 Ohms.	
23, 21, 19	Vdd1, Vdd2, Vdd3	Power Supply Voltage for the amplifier. External bypass capacitors of 100 pF, 1000pF, and 2.2 μF are required.	

### Application Circuit

Component	Value
C1	100 pF
C2	1,000 pF
C3	2.2 μF

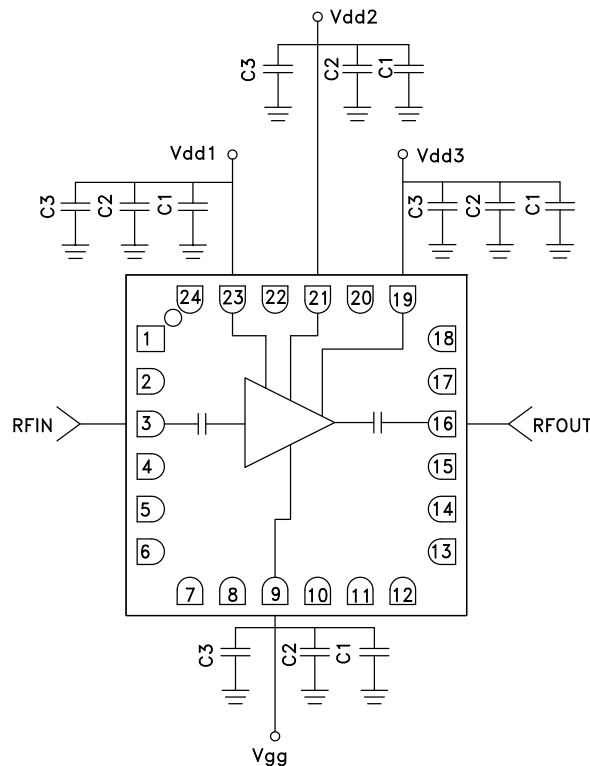

### Evaluation PCB

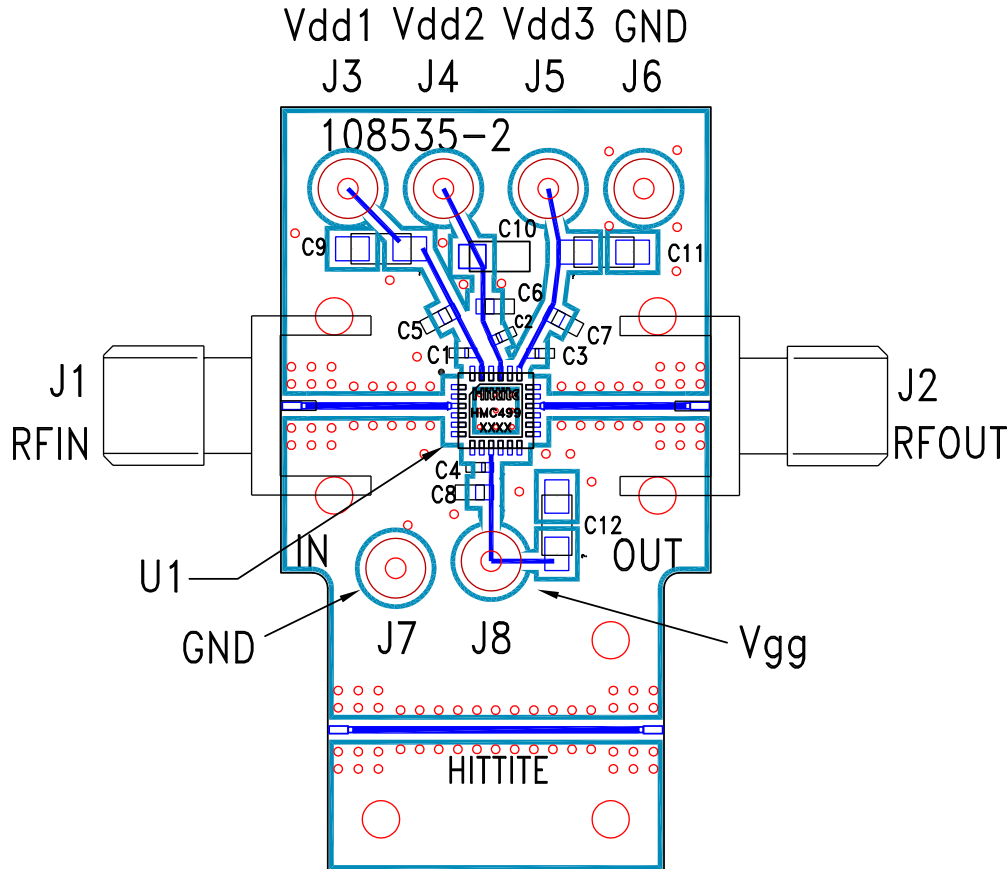

### List of Material for Evaluation PCB 108537 [1]

Item	Description
J1, J2	2.92 mm PC mount K-connector
J3 - J8	DC Pin
C1 - C4	100 pF capacitor, 0402 pkg.
C5 - C8	1,000 pF Capacitor, 0603 pkg.
C9 - C12	2.2μF Capacitor, Tantalum
U1	HMC498LC4 Amplifier
PCB [2]	108535 Evaluation PCB

[1] Reference this number when ordering complete evaluation PCB

[2] Circuit Board Material: Rogers 4350.

The circuit board used in this application should use RF circuit design techniques. Signal lines should have 50 Ohm impedance while the package ground leads and exposed paddle should be connected directly to the ground plane similar to that shown. A sufficient number of via holes should be used to connect the top and bottom ground planes. The evaluation board should be mounted to an appropriate heat sink. The evaluation circuit board shown is available from Hittite upon request.