

PART NUMBER	REV	POWER UNIT	FEED TYPE
1-1855466-1	A	LEADMAKER & BENCH MODEL G/K	2.3mm AIR FEED
1-1855466-2	A	LEADMAKER & BENCH MODEL G/K	4.6mm AIR FEED
1-1855466-3	A	LEADMAKER & BENCH MODEL G/K	6.9mm AIR FEED
1-1855466-4	A	LEADMAKER & BENCH MODEL G/K	9.2mm AIR FEED
1-1855466-5	A	LEADMAKER & BENCH MODEL G/K	11.5mm AIR FEED
7-1855466-1	A	SPARE PARTS	2.3mm AIR FEED
7-1855466-2	A	SPARE PARTS	4.6mm AIR FEED
7-1855466-3	A	SPARE PARTS	6.9mm AIR FEED
7-1855466-4	A	SPARE PARTS	9.2mm AIR FEED
7-1855466-5	A	SPARE PARTS	11.5mm AIR FEED

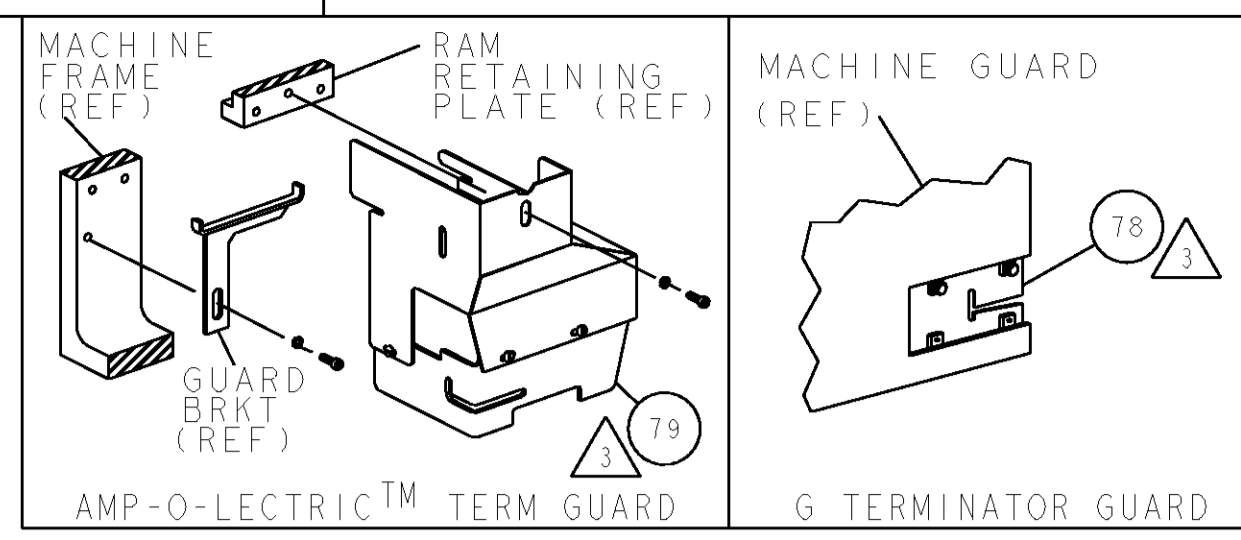

TE PN		STOCKO PN	STOCKO TERMINAL - TE CRIMP SPECS		REF SETTING*
1572807	RSB 7735.001 V-1.5				
			CRIMP HEIGHT	WIRE SIZE	REF SETTING*
			1.53±0.05mm [.060±.002]	1.5mm2	B5
			1.46±0.05mm [.058±.002]	16AWG or 1.25mm2	C4
			1.35±0.05mm [.053±.002]	1mm2	C9
			1.30±0.05mm [.051±.002]	18AWG or 0.8mm2	D1
		CRIMP	SIZE	TYPE	RANGE
		WIRE	2.29mm [.090]	F	0.5-1.5mm2/20-16AWG
		INSUL			
WIRE STRIP LENGTH	TERM APPL SPEC	FEED	APPL INSTRUCTIONS	SET UP GAGE	
4	NONE	4	408-8039	458638-1	

ADDITIONAL CRIMP HEIGHTS		
CRIMP HEIGHT	WIRE SIZE	REF SETTING*
1.26±0.05mm [.049±.002]	0.75mm2	D3
1.18±0.05mm [.047±.002]	20AWG or 0.5mm2	E2

- △ RECOMMENDED SPARE PARTS
- △ GREASE LIGHTLY
- △ GUARD MUST BE IN PLACE WHEN OPERATING APPLICATOR IN A BENCH MACHINE
- △ APPLICATOR CRIMPS 1, 2, 3, 4 OR 5 SETS OF LEGS ON TERMINAL.

LEGS	FEED	STRIP LENGTH
1	2.3mm	2.3mm±0.4
2	4.6mm	4.6mm±0.4
3	6.9mm	6.9mm±0.4
4	9.2mm	9.2mm±0.4
5	11.5mm	11.5mm±0.4

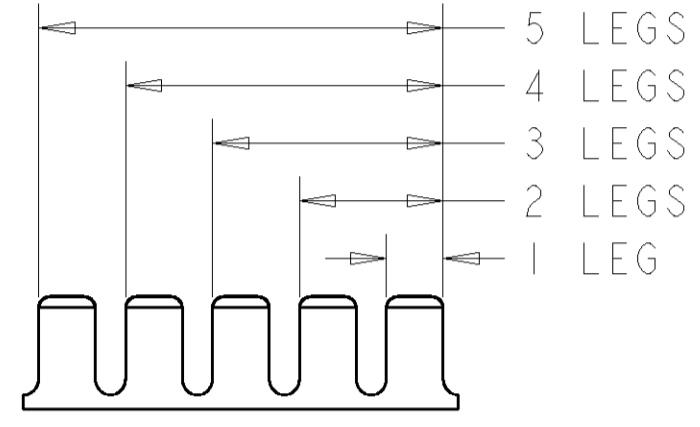

***WARNING:**
 ON INSTALLATION, SET WIRE DISC TO LARGEST WIRE SIZE SETTING. USE OF SETTINGS BELOW MIN REQUIRED CRIMP HEIGHT SETTING WILL CAUSE DAMAGE TO CRIMP TOOLING.

- △ USE ON "G" TERMINATOR ONLY
- △ USE ON "K" TERMINATOR ONLY
- △ CUT TO LENGTH AT ASSEMBLY.

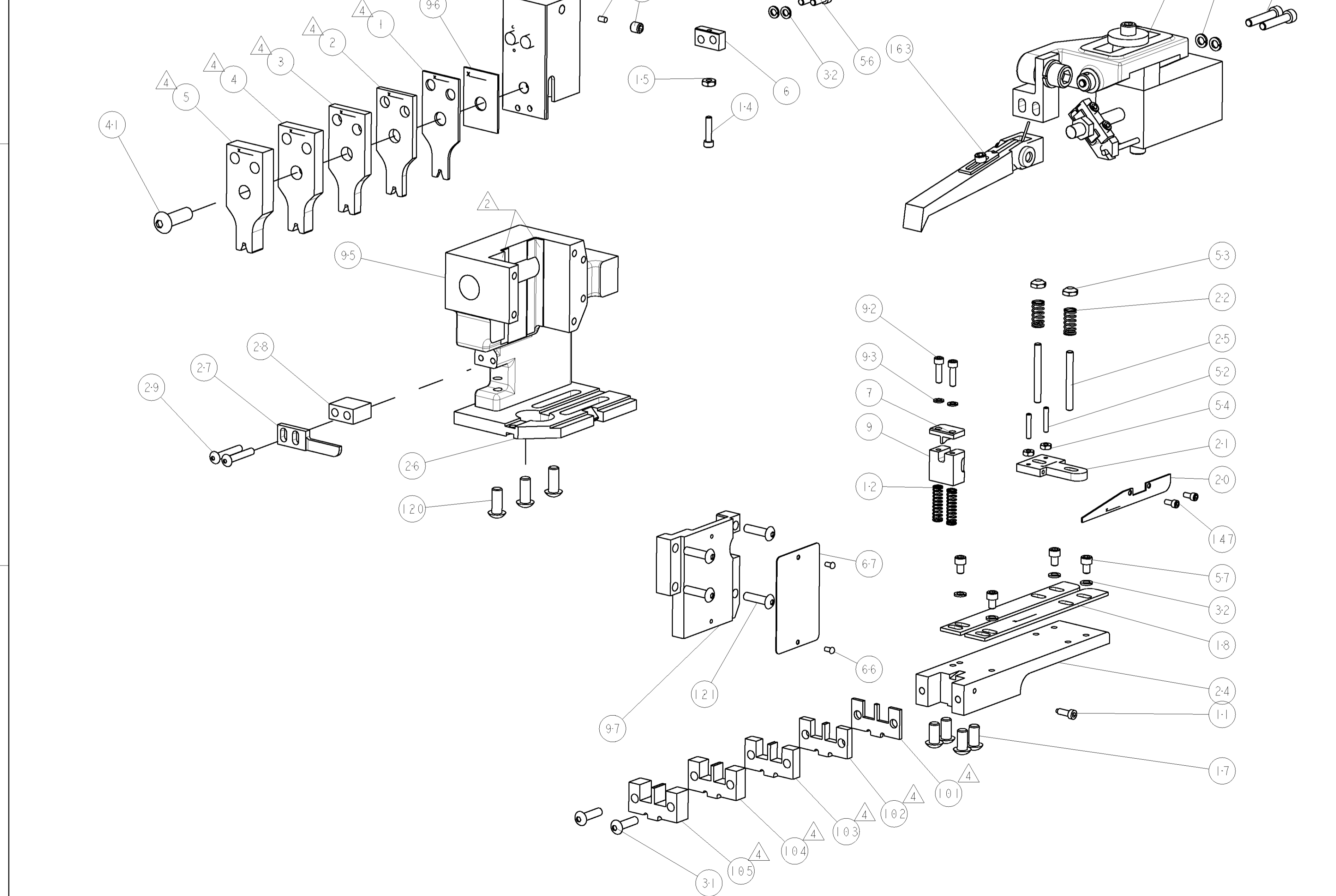

LOC	DIST	REV	DESCRIPTION	DATE	OWN	APVD
A	66		RELEASED	03APR2009	RK	TE
5			23238-1			170
			460680-2			163
			692655-5			161
			460277-1			160
			1-21000-3			147
			3-21000-9			123
			21024-5			122
			2-21002-9			121
			2-22733-8			120
			692655-6			118
			24042-2			106
			5-690618-7			105
			5-690618-6			104
			5-690618-5			103
			5-690618-4			102
			5-690618-3			101
			454220-1			97
			1-455888-0			96
			453736-1			95
			21024-3			93
			2-21000-0			92
			455745-1			79
			679532-1			78
			217238-1			72
			4088039			71
			461264-5			67
			21017-2			66
			21009-2			63
			2-21000-5			57
			9-21000-9			56
			21018-4			54
			21022-2			53
			2-21006-6			52
			690191-1			45
			455674-8			44
			7-21002-9			41
			690125-1			39
			469367-7			38
			879103-4			37
			21024-4			32
			2-21002-9			31
			8-21002-9			29
			3-690451-1			28
			240639-1			27
			455676-1			26
			22354-8			25
			1633720-1			24
			2-22281-3			22
			464451-1			21
			464452-1			20
			454204-2			18
			3-21002-3			17
			21018-5			15
			2-21000-1			14
			2-22280-0			12
			2-690461-1			11
			1633721-1			9
			1633722-3			7
			690753-8			6
			1-1633730-1			5
			1-1633730-0			4
			1633730-9			3
			1633730-8			2
			1633730-7			1

TYCO ELECTRONICS CORPORATION, 17105-3608 HARRISBURG, PA 17105-3608

DRN: R. KNEPPER 19FEB2009
 CHK: T. ELBIN 03APR2009
 APVD: W. DEMING 03APR2009

PRODUCT SPEC: FINE ADJUST END FEED HDM APPLICATOR

APPLICATION SPEC: -

SIZE: A11 CAGE CODE: 00779 DRAWING NO: 1855466

SCALE: 13:1 SHEET: 1 OF 1 REV: A

CUSTOMER DRAWING

Mouser Electronics

Authorized Distributor

Click to View Pricing, Inventory, Delivery & Lifecycle Information:

[TE Connectivity:](#)

[1-1855466-1](#)