

PART NUMBER	REV	FIRST USED	POWER UNIT	FEED TYPE	DESCRIPTION
1852601-1	A	122500-1	LEADMAKER	AIR FEED	CUTS CARRIER
1852601-2	A	565435-5	BENCH MODEL K	AIR FEED	CUTS CARRIER
1852601-3	A	354500-1	BENCH MODEL G	AIR FEED	CUTS CARRIER
1852601-6	A	122500-1	LEADMAKER	AIR FEED	CONTINUOUS CARRIER
7-1852601-7	A	-	-	-	SPARE PARTS

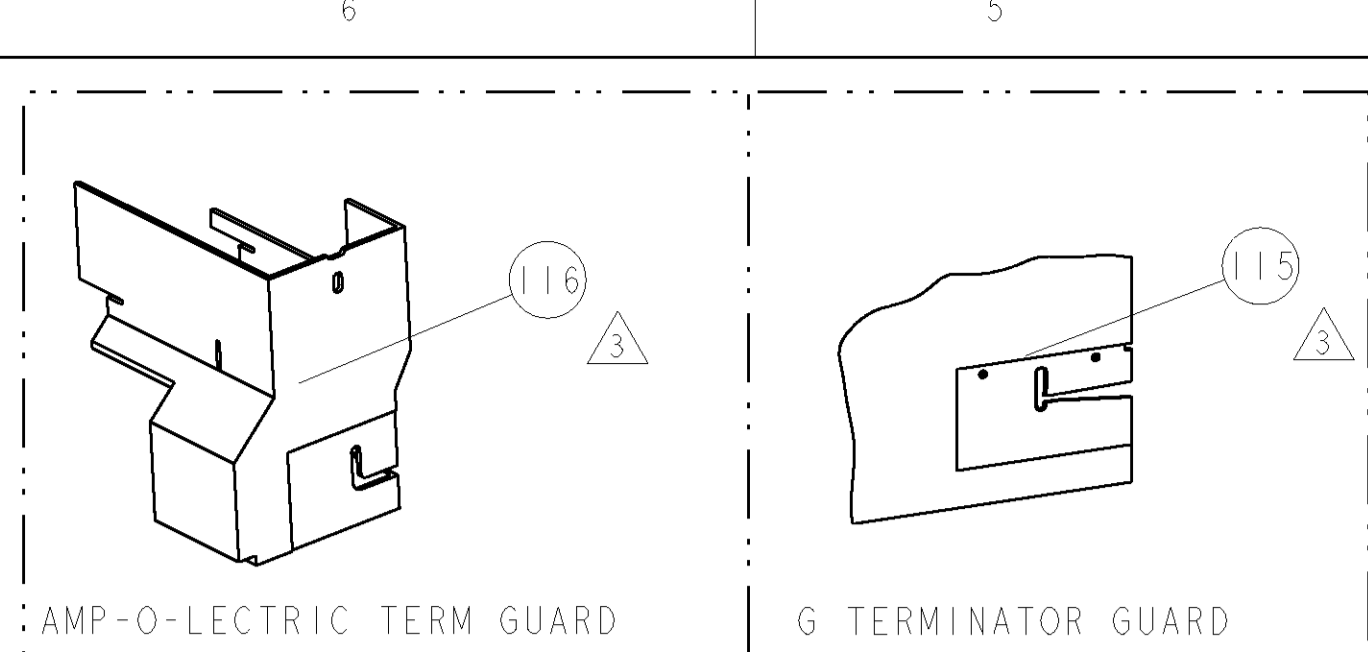

TE P/N		SIEMENS P/N	SIEMENS TERMINAL - TE CRIMP SPECS		REF SETTING
1949569		40132226			
			CRIMP HEIGHT	WIRE SIZE	
			1.17mm ± .05 / -.05 [ .046 ± .002 / -.002 ]	22AWG	
			CRIMP	SIZE	TYPE
					RANGE
			WIRE	1.78mm [ .070 ]	F
			INSUL	2.29mm [ .090 ]	F
					Ø 1.600 MAX
WIRE STRIP LENGTH	4.534-4.915	TERM APPL SPEC	NONE	FEED	24.079
				APPLICATOR INSTRUCTIONS	408-8040
				SET UP GAGE	458637-1

- △ RECOMMENDED SPARE PARTS
- △ GREASE LIGHTLY
- △ GUARD MUST BE IN PLACE WHEN OPERATING APPLICATOR IN A BENCH MACHINE

**\* WARNING**  
ON INSTALLATION, SET WIRE DISC TO LARGEST WIRE SIZE SETTING. USE OF SETTINGS BELOW MIN. REQUIRED CRIMP HEIGHT SETTING WILL CAUSE DAMAGE TO CRIMP TOOLING.

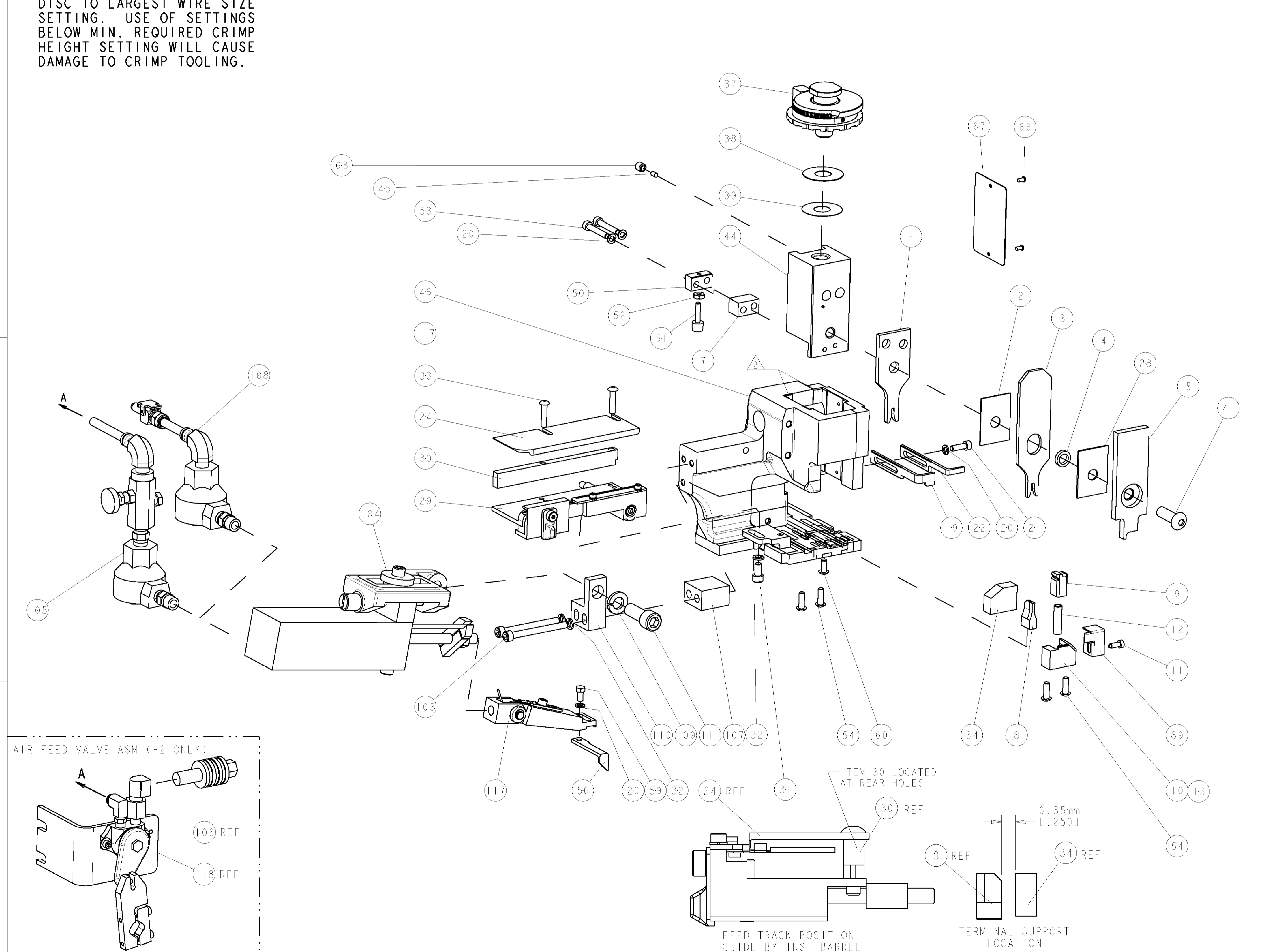

LOC	DIST	REV	DESCRIPTION	DATE	DWN	APVD
A	66					
		A	RELEASED	28DEC2007	RK	TE
		A1	ECR-09-004661	27FEB2009	MY	GB

-	-	-	REF	-	-	692655-6	AIR FEED VALVE ASSEMBLY	118
-	1	1	1	1	-	461062-1	FEED FINGER ASSEMBLY	117
-	-	-	REF	-	..	455749-1	GUARD WINDOW	116
-	-	-	REF	-	..	679532-1	INSERT, GUARD	115
-	1	1	1	1	-	3-21001-5	SCR, SKT HD CAP 3/8-16 X 1.000	111
-	1	1	1	1	-	459610-1	MOUNT, FEED BRACKET	110
-	1	1	1	1	-	21024-8	WASHER, SPRG LOCK, REG 3/8	109
-	1	1	-	1	-	692655-7	AIR FEED VALVE ASSEMBLY	108
-	1	1	1	1	-	461690-1	SPACER, AIR FEED	107
-	-	-	REF	-	-	24024-2	VALVE, SHUT OFF	106
-	-	-	1	-	-	692655-5	AIR FEED VALVE ASSEMBLY	105
-	1	1	1	1	-	461065-2	ASSEMBLY, AIR FEED	104
-	2	2	2	2	-	4-21000-3	SCR, SKT HD CAP 10-32 X 2.000	103
-	1	1	1	1	-	318563-1	GUARD, FRONT CHIP	89
-	1	1	1	1	-	4088040	SF APPL INST 408-8040	72
-	1	1	1	1	-	217238-1	GENERAL INSTRUCTION PKG	71
-	1	1	1	1	-	461264-5	PLATE, IDENTIFICATION	67
-	2	2	2	2	-	21017-2	SCREW, DRIVE	66
-	1	1	1	1	-	21009-2	SCR, SET, SELF LOCKING 1/4-20 X .250	63
-	1	1	1	1	-	22733-8	SCR, BHSC, SELF-LOCKING, 8-32 X .375	60
-	1	1	1	1	-	2-22603-0	SCR, HEX HD CAP 8-32 X .312	59
-	1	1	1	1	-	458537-2	PAWL, FEED	56
-	4	4	4	4	-	2-21002-2	SCR, BTN SKT HD CAP 8-32 X .500	54
-	2	2	2	2	-	3-21000-1	SCR, SKT HD CAP 8-32 X 1.000	53
-	1	1	1	1	-	21018-5	NUT, HEX, REG 6-32	52
-	1	1	1	1	-	811242-2	BUMPER, HOLD DOWN	51
-	1	1	1	1	-	690753-1	SPACER, TONKER	50
-	1	1	1	1	-	1633399-1	APPL., BASIC AIR FEED SUB ASSY	46
-	1	1	1	1	-	690191-1	PLUG, NYLON	45
-	1	1	1	1	-	455673-1	RAM, SIDE FEED	44
-	1	1	1	1	-	7-21002-9	SCR, BTN SKT HD CAP 5/16-24 X 1.00	41
-	1	1	1	1	-	690125-1	SHIM SUB-ASSY	39
-	1	1	1	1	-	469367-9	SHIM	38
-	1	1	1	1	-	879103-3	FINE ADJUST HEAD ASSEMBLY	37
-	1	1	1	1	-	690786-1	TERMINAL SUPPORT	34
-	2	2	2	2	-	2-21002-4	SCR, BTN SKT HD CAP 8-32 X .750	33
-	3	3	3	3	-	21024-5	WASHER, SPRG LOCK, REG NO 10	32
-	1	1	1	1	-	3-21000-4	SCR, SKT HD CAP 10-32 X .375	31
-	1	1	1	1	-	1320908-4	SPACER, STRIP GUIDE	30
-	1	1	1	1	-	1-1633091-2	ASSEMBLY, STRIP GUIDE	29
-	1	1	1	1	-	1-455888-0	SPACER, CRIMPER	28
-	1	1	1	1	-	1320928-5	PLATE, STRIP GUIDE	24
-	1	1	1	1	-	690472-2	STRIPPER	22
-	1	1	1	1	-	2-21000-7	SCR, SKT HD CAP 8-32 X .500	21
-	4	4	4	4	-	21024-4	WASHER, SPRG LOCK, REG NO 8	20
-	-	1	1	-	-	691353-1	STRIPPER	19
-	1	1	1	1	-	679625-1	SHEAR HOLDER, FRONT (NO CUT)	13
-	1	1	1	1	-	3-22280-3	SPRING, COMPRESSION	12
-	1	1	1	1	-	690461-1	STOP, SHEAR	11
-	-	1	1	1	-	690459-1	SHEAR HOLDER, FRONT	10
-	1	1	1	1	-	462006-1	FLOATING SHEAR, FRONT	9
1	1	1	1	1	-	3-1633108-1	ANVIL, COMBINATION .070	8
-	1	1	1	1	-	2-240641-6	SPACER	7
-	-	-	-	-	..	-	-	6
-	1	1	1	1	-	2-455889-0	DEPRESSOR, SHEAR	5
-	1	1	1	1	-	238011-9	BLOCK, CRIMPER SPACER	4
1	1	1	1	1	-	4-1424909-4	CRIMPER, INSULATION F	3
-	1	1	1	1	-	455888-6	SPACER, CRIMPER	2
1	1	1	1	1	-	456404-9	CRIMPER, WIRE PREMIUM	1

DIMENSIONS: INCHES		TOLERANCES UNLESS OTHERWISE SPECIFIED:		DWN: R. KNEPPER 12DEC2007		CHK: T. ELBIN 28DEC2007		APVD: M. DEMING 28DEC2007		NAME: FINE ADJUST SIDE FEED HDM APPLICATOR	
Ø	9 PLC ±.001	9 PLC ±.001	9 PLC ±.001	9 PLC ±.001	9 PLC ±.001	9 PLC ±.001	9 PLC ±.001	9 PLC ±.001	9 PLC ±.001	9 PLC ±.001	9 PLC ±.001
Ø	3 PLC ±.001	3 PLC ±.001	3 PLC ±.001	3 PLC ±.001	3 PLC ±.001	3 PLC ±.001	3 PLC ±.001	3 PLC ±.001	3 PLC ±.001	3 PLC ±.001	3 PLC ±.001
Ø	4 PLC ±.0001	4 PLC ±.0001	4 PLC ±.0001	4 PLC ±.0001	4 PLC ±.0001	4 PLC ±.0001	4 PLC ±.0001	4 PLC ±.0001	4 PLC ±.0001	4 PLC ±.0001	4 PLC ±.0001
Ø	ANGLES ±.0001	ANGLES ±.0001	ANGLES ±.0001	ANGLES ±.0001	ANGLES ±.0001	ANGLES ±.0001	ANGLES ±.0001	ANGLES ±.0001	ANGLES ±.0001	ANGLES ±.0001	ANGLES ±.0001
MATERIAL:	FINISH:	WEIGHT:	SCALE:	3:5	SHEET:	1	OF:	1	REV:	A1	RESTRICTED TO:
CUSTOMER DRAWING		SCALE:		3:5		SHEET:		1		OF:	

CUSTOMER VIEWABLE ASSEMBLY

# Mouser Electronics

Authorized Distributor

Click to View Pricing, Inventory, Delivery & Lifecycle Information:

[TE Connectivity:](#)

[1852601-3](#)