

PART NUMBER	REV	FIRST USED	POWER UNIT	FEED TYPE	DESCRIPTION
1855485-1	1	122500-1	LEADMAKER	AIR FEED	CUTS CARRIER
1855485-2	1	565435-5	BENCH MODEL K	AIR FEED	CUTS CARRIER
1855485-3	1	354500-1	BENCH MODEL G	AIR FEED	CUTS CARRIER
1855485-6	1	122500-1	LEADMAKER	AIR FEED	CONTINUOUS CARRIER
7-1855485-7	1	-	-	-	SPARE PARTS

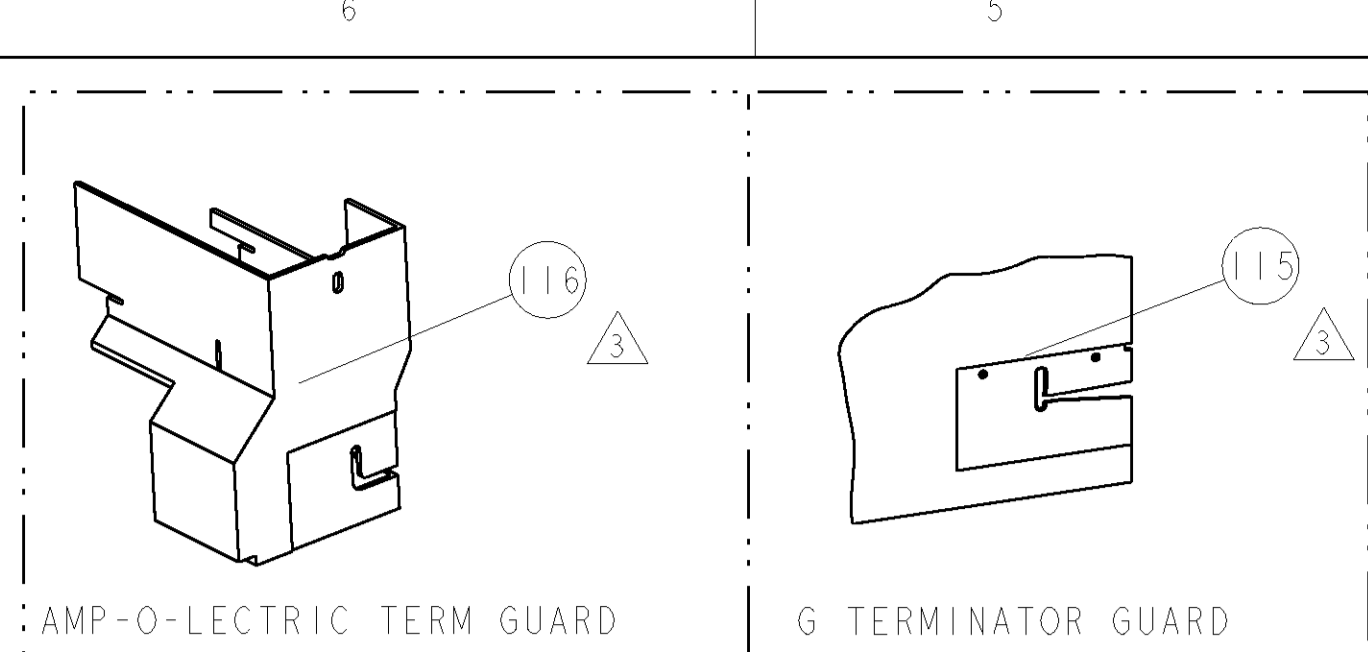

TERMINAL NAME: L TYPE CONNECTOR FEMALE TERMINAL					
TE PN	YAZAKI	YAZAKI TERMINAL - TE CRIMP SPECS		REF SETTING	
1949897	7116-3257-02				
-	-	CRIMP HEIGHT	WIRE SIZE		
-	FORD PN	2.48mm±.05/-.05[.098±.002/- .002]	12AWG or 3mm2		
-	F65B-14474-HA				
-	-	CRIMP	SIZE	TYPE	RANGE
-	-	WIRE	4.06mm [.160]	F	3mm2
-	-	INSUL	5.84mm [.230]	F	∅3.560 MAX
WIRE STRIP LENGTH	TERM APPL SPEC	FEED	APPLICATOR INSTRUCTIONS		SET UP GAGE
7.59-7.97	TE	27.00	408-8040		458637-1

LOC	DIST	REVISIONS			
A	66	REV	DESCRIPTION	DATE	DWN

- △ RECOMMENDED SPARE PARTS
- △ GREASE LIGHTLY
- △ GUARD MUST BE IN PLACE WHEN OPERATING APPLICATOR IN A BENCH MACHINE

**\* WARNING**  
ON INSTALLATION, SET WIRE DISC TO LARGEST WIRE SIZE SETTING. USE OF SETTINGS BELOW MIN. REQUIRED CRIMP HEIGHT SETTING WILL CAUSE DAMAGE TO CRIMP TOOLING.

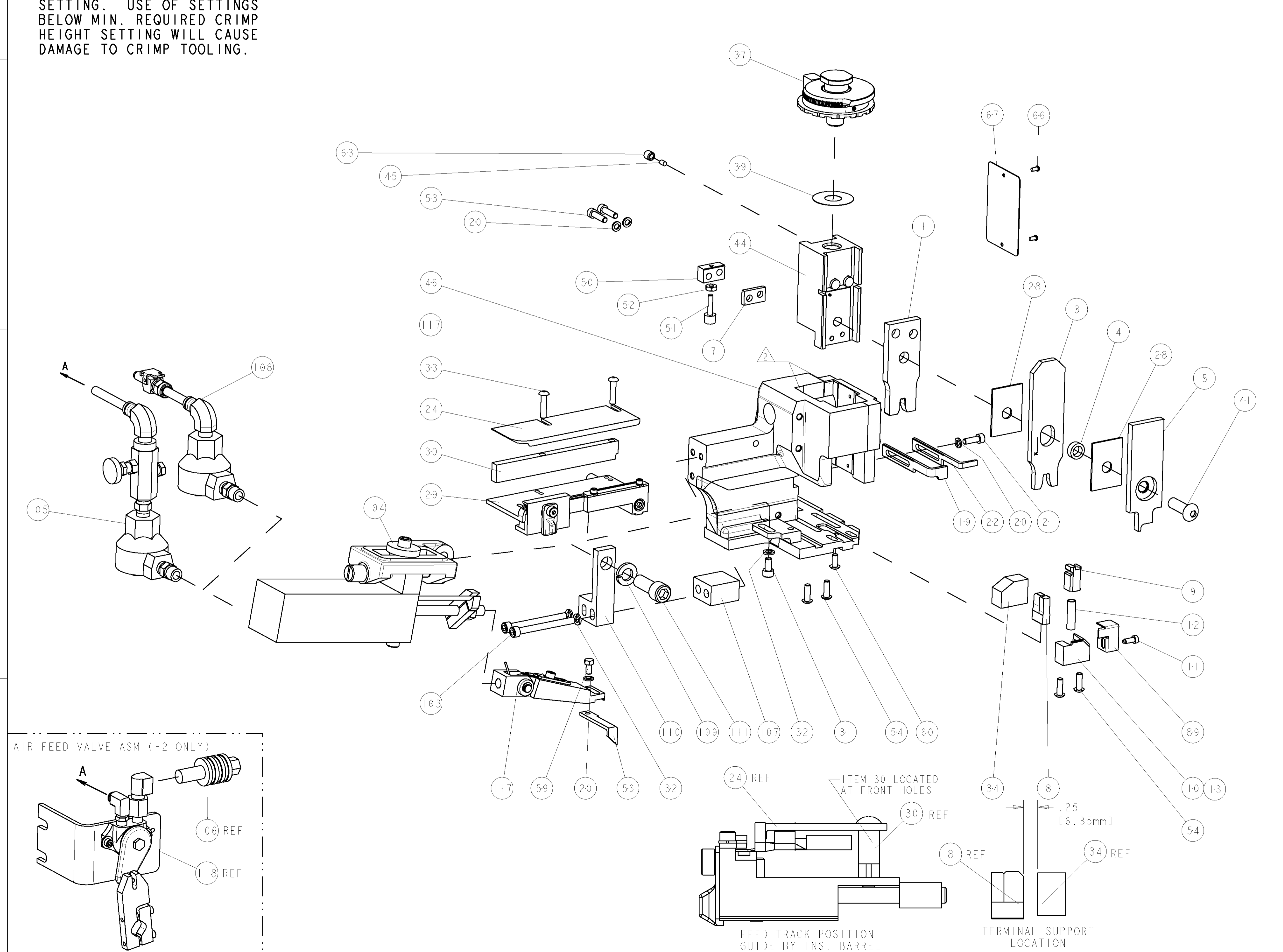

-	-	REF	-	-	692655-6	AIR FEED VALVE ASSEMBLY	118
-	-	REF	-	-	461062-1	FEED FINGER ASSEMBLY	117
-	-	REF	-	-	455749-1	GUARD WINDOW	116
-	-	REF	-	-	679532-1	INSERT, GUARD	115
-	-	REF	-	-	3-21001-5	SCR, SKT HD CAP 3/8-16 X 1.000	111
-	-	REF	-	-	459610-3	MOUNT, FEED BRACKET	110
-	-	REF	-	-	21024-8	WASHER, SPRG LOCK, REG 3/8	109
-	-	REF	-	-	692655-7	AIR FEED VALVE ASSEMBLY	108
-	-	REF	-	-	461690-1	SPACER, AIR FEED	107
-	-	REF	-	-	24024-2	VALVE, SHUT OFF	106
-	-	REF	-	-	692655-5	AIR FEED VALVE ASSEMBLY	105
-	-	REF	-	-	461065-2	ASSEMBLY, AIR FEED	104
-	2	2	2	2	4-21000-3	SCR, SKT HD CAP 10-32 X 2.000	103
-	-	REF	-	-	318563-1	GUARD, FRONT CHIP	89
-	-	REF	-	-	4088040	SF APPL INST 408-8040	72
-	-	REF	-	-	217238-1	GENERAL INSTRUCTION PKG	71
-	-	REF	-	-	461264-5	PLATE, IDENTIFICATION	67
-	2	2	2	2	21017-2	SCREW, DRIVE	66
-	-	REF	-	-	21009-2	SCR, SET, SELF LOCKING 1/4-20 X .250	63
-	-	REF	-	-	22733-8	SCR, BHSC, SELF-LOCKING, 8-32 X .375	60
-	-	REF	-	-	2-22603-0	SCR, HEX HD CAP 8-32 X .312	59
-	-	REF	-	-	458537-2	PAWL, FEED	56
-	4	4	4	4	2-21002-2	SCR, BTN SKT HD CAP 8-32 X .500	54
-	2	2	2	2	2-21000-8	SCR, SKT HD CAP 8-32 X .625	53
-	-	REF	-	-	21018-5	NUT, HEX, REG 6-32	52
-	-	REF	-	-	811242-2	BUMPER, HOLD DOWN	51
-	-	REF	-	-	690753-1	SPACER, TONKER	50
-	-	REF	-	-	1633399-7	APPL. BASIC AIR FEED SUB ASSY	46
-	-	REF	-	-	690191-1	PLUG, NYLON	45
-	-	REF	-	-	819307-6	RAM, SIDE FEED	44
-	-	REF	-	-	7-21002-9	SCR, BTN SKT HD CAP 5/16-24 X 1.00	41
-	-	REF	-	-	690125-1	SHIM SUB-ASSY	39
-	-	REF	-	-	879103-2	FINE ADJUST HEAD ASSEMBLY	37
-	-	REF	-	-	690786-3	TERMINAL SUPPORT	34
-	2	2	2	2	2-21002-4	SCR, BTN SKT HD CAP 8-32 X .750	33
-	3	3	3	3	21024-5	WASHER, SPRG LOCK, REG NO 10	32
-	-	REF	-	-	3-21000-4	SCR, SKT HD CAP 10-32 X .375	31
-	-	REF	-	-	1320908-3	SPACER, STRIP GUIDE	30
-	-	REF	-	-	1633091-7	ASSEMBLY, STRIP GUIDE	29
-	-	REF	-	-	1-455888-0	SPACER, CRIMPER	28
-	-	REF	-	-	1320928-5	PLATE, STRIP GUIDE	24
-	-	REF	-	-	690472-2	STRIPPER	22
-	-	REF	-	-	2-21000-7	SCR, SKT HD CAP 8-32 X .500	21
-	4	4	4	4	21024-4	WASHER, SPRG LOCK, REG NO 8	20
-	-	REF	-	-	691353-1	STRIPPER	19
-	-	REF	-	-	679625-1	SHEAR HOLDER, FRONT (NO CUT)	13
-	-	REF	-	-	3-22280-3	SPRING, COMPRESSION	12
-	-	REF	-	-	690461-1	STOP, SHEAR	11
-	-	REF	-	-	690459-1	SHEAR HOLDER, FRONT	10
-	-	REF	-	-	454276-1	FLOATING SHEAR, FRONT	9
-	-	REF	-	-	2-1633544-8	ANVIL, COMBINATION	8
-	-	REF	-	-	240641-5	SPACER	7
-	-	REF	-	-	-	-	6
-	-	REF	-	-	1-455889-4	DEPRESSOR, SHEAR	5
-	-	REF	-	-	238011-3	BLOCK, CRIMPER SPACER	4
-	-	REF	-	-	1-683453-4	CRIMPER, INSULATION PREMIUM	3
-	-	REF	-	-	1-455888-0	SPACER, CRIMPER	2
-	-	REF	-	-	456414-4	CRIMPER, WIRE	1

INCHES	TOLERANCES UNLESS OTHERWISE SPECIFIED:	DIMENSIONS:	FINISH	WEIGHT	CUSTOMER DRAWING
0 PLC	±	9 PLC			
1 PLC	±0.1	1 PLC			
2 PLC	±0.01	2 PLC			
3 PLC	±0.001	3 PLC			
4 PLC	±0.0001	4 PLC			
ANGLES	±0.0001	ANGLES			

# Mouser Electronics

Authorized Distributor

Click to View Pricing, Inventory, Delivery & Lifecycle Information:

[TE Connectivity:](#)

[1855485-1](#)