



AMPMODU 50/50 Grid Connectors

Product Facts

- Surface-mount products for parallel board-to-board applications, as well as right angle board-to-board and cable-to-board applications
- High density 1.27 x 1.27 [.050 x .050] centerline grid
- Three board-to-board stack heights: 6.35 [.250], 8.13 [.320] and 9.91 [.390]
- Non-protrusive metallic holddowns
- Reliable dual beam receptacle contacts for redundant contact
- Duplex plated receptacle and post contacts; gold plated on mating areas, tin-lead plated on tails
- Compatible with standard surface-mount processing (VPR and IR)
- Receptacle and header allow for drainage of processing fluids
- Tape and reel packaging available, contact Tyco Electronics for details
- Polarized header and receptacle assemblies
- Sizes of 10, 20, 30, 40, 50, 60, 70, 80 and 100 positions
- Recognized under the Component Program of Underwriters Laboratories Inc., File No. E28476 
- Certified by Canadian Standards Association File No. LR7189 

See Catalog 1307819 for additional AMPMODU product offerings.

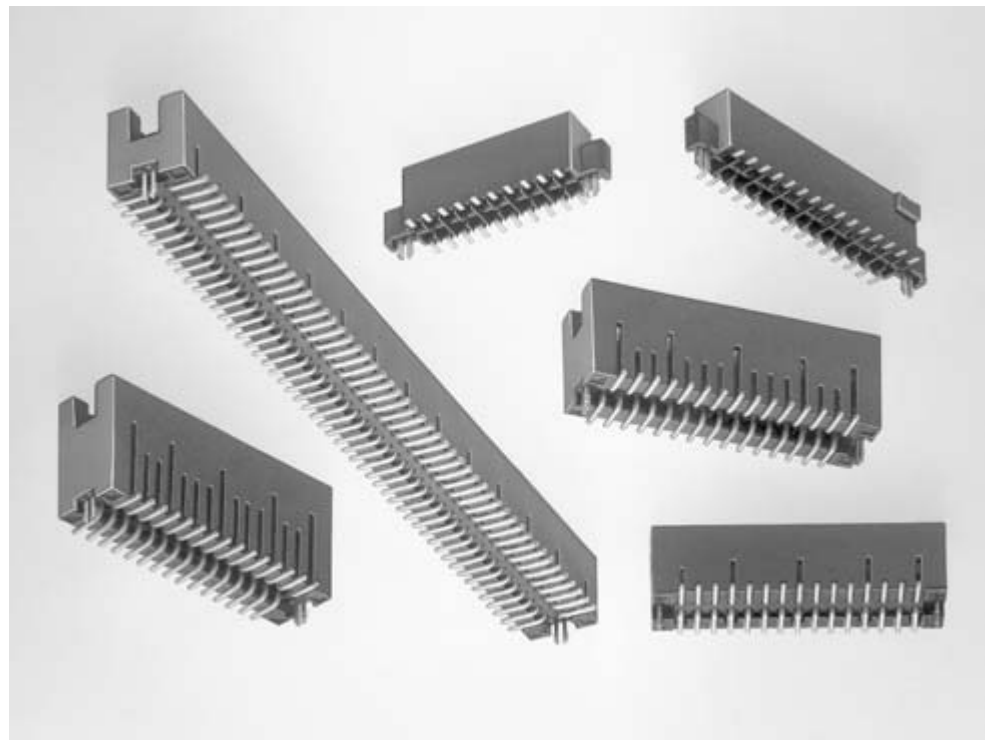

AMPMODU 50/50 Grid Vertical Headers and Receptacles are designed for parallel board-to-board stacking in high density applications.

Right angle board-to-board and cable-to-board applications are also possible, since the vertical receptacles also mate with non-latching right angle headers (page 95) and the vertical headers also mate with non-latching cable connectors.

Available are dual-row, vertical shrouded headers and receptacles in sizes ranging from 10 through 100 positions (in 10 position increments).

Parallel board-to-board stack heights of 6.35 [.250], 8.13 [.320] and 9.91 [.390] are achievable by selection of the appropriate header. The receptacle is the same for all three stack height headers.

Non-protrusive metallic holddowns are designed for use in 1.57 [.062] or thicker

PC boards and allow surface mounting to both sides of the board. In addition to providing retention during processing, the holddowns are soldered during reflow and therefore provide long term strain relief for the lead solder joints.

AMPMODU 50/50 Grid Vertical Headers and Receptacles are compatible with standard surface-mount processes; IR (infrared) and VPR (vapor phase reflow). The surface-mount connectors have been designed so that dimensioning, tolerances, referenced datums, hold-

down characteristics and packaging methods result in a system that is compatible with robotic assembly. The headers and receptacles feature polarization to prevent misalignment.

Three Board Stack Heights

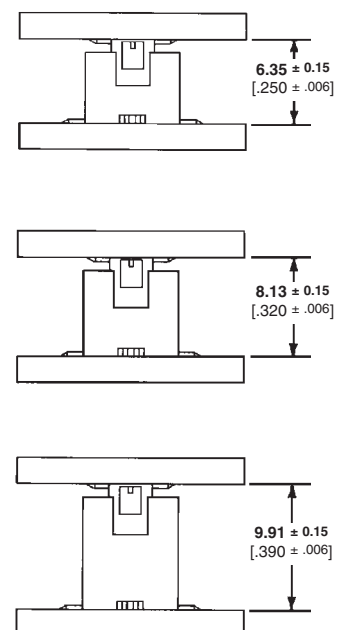

Non-Protrusive Metallic Holddowns

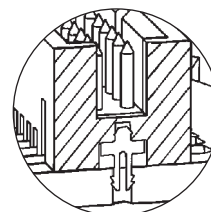

1.27mm AMPMODU 50/50 Grid Connectors

AMPMODU 50/50 Grid Connector System

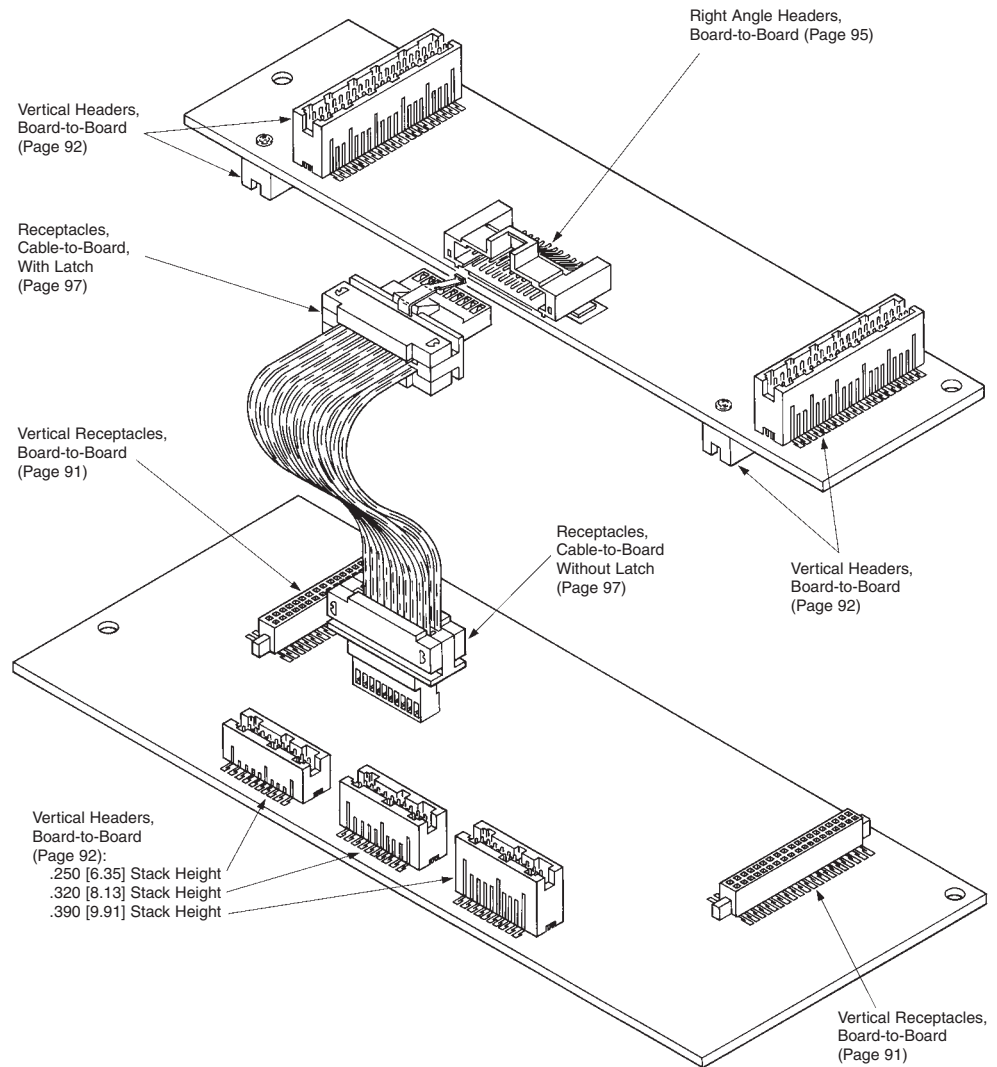

1.27mm AMPMODU 50/50 Grid Connectors

Produced under a Quality Management System certified to ISO 9001

A copy of the certificate is available upon request.



**Board-to-Board Vertical Receptacles, Dual-Row, 1.27 x 1.27
[.050 x .050] Centerline**



Material and Finish

Housing — Glass-filled thermoplastic, black, 94V-0 rated

Contacts — Copper alloy; duplex plated 0.00076 [.000030] gold in mating area, 0.00381 [.000150] tin on solder tail, with entire contact underplated 0.00127 [.000050] nickel

Holddown — Copper alloy; plated 0.00381 [.000150] tin over 0.00127 [.000050] nickel

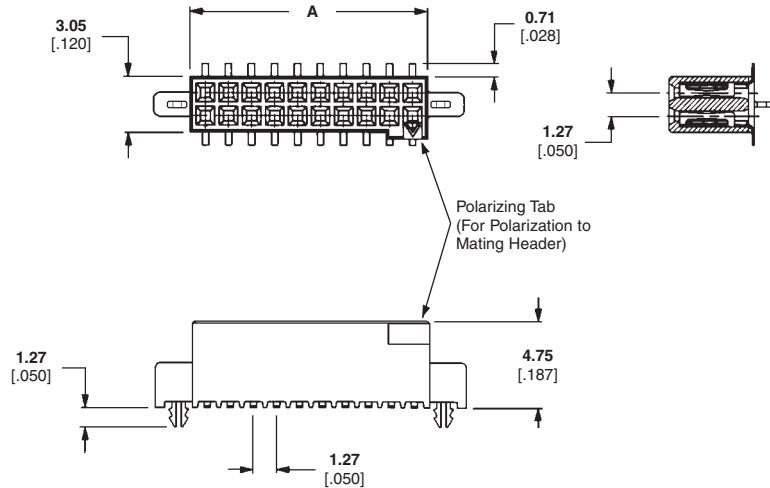

Related Product Data

Mating Headers — pages 92, 95

PC Board Layouts — page 93

Technical Documents (page 113)

Product Specification 108-1332

Application Specification
114-7010

Packaging: Tube or Tape and Reel

No. of Pos.	Dimension A	Receptacle Part Numbers		
		Tube	Tape and Reel*	No Hold Down w/Vacuum Cover
10	6.75 [.266]	5-104652-1	5-147384-1	5-147413-1
20	13.11 [.516]	5-104652-2	5-147384-2	5-147413-3
30	19.46 [.766]	5-104652-3	5-147384-3	5-147413-4
40	25.81 [1.016]	5-104652-4	5-147384-4	—
50	32.16 [1.266]	5-104652-5	5-147384-5	5-147413-2
60	38.51 [1.516]	5-104652-6	5-147384-6	—
70	44.86 [1.766]	5-104652-7	5-147384-7	—
80	51.21 [2.016]	5-104652-8	5-147384-8	—
100	63.91 [2.516]	6-104652-0	5-147384-9	—

* Parts packaged in tape and reel have vacuum pick and place cover. See PC Board Layout on page 93.

Note: Part Numbers are RoHS compliant.

1.27mm AMPMODU 50/50 Grid Connectors

**Board-to-Board Vertical Headers, Dual-Row, 1.27 x 1.27
[.050 x .050] Centerline**



For 6.35 [.250] Mated Height

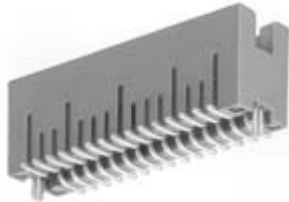

For 8.13 [.320] Mated Height

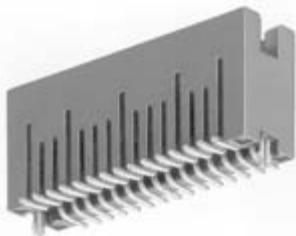

For 9.91 [.390] Mated Height

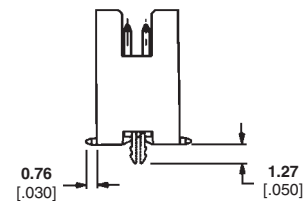
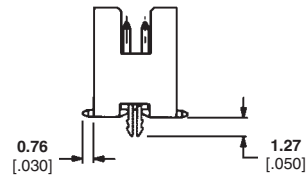
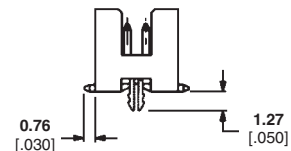
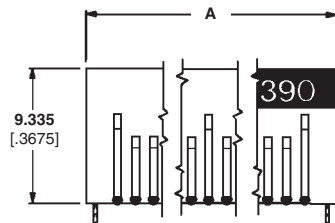
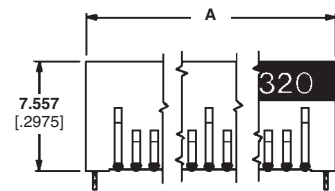
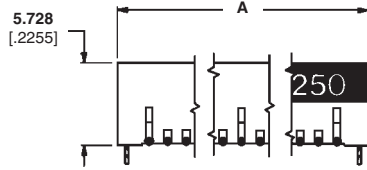
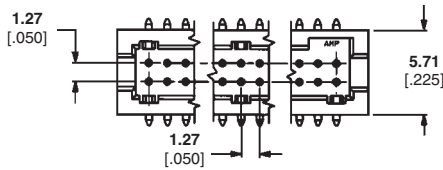

Material and Finish

Housing — Glass-filled thermoplastic, black, 94V-0 rated

Contacts — Phosphor bronze; duplex plated 0.00076 [.000030] gold in mating area, 0.00381 [.000150] tin on solder tail, with entire contact underplated 0.00127 [.000050] nickel

Holddown — Copper alloy; plated 0.00381 [.000150] tin over 0.00127 [.000050] nickel

Related Product Data

Mating Receptacles — pages 91, 97 (without latch only)

PC Board Layouts — page 93

Technical Documents (page 113)

Product Specification 108-1332

Application Specification 114-7010

Packaging: Tube or Tape and Reel

No. of Pos.	Dimension A	Header Part Numbers								
		.250 [6.35] Mated Height			.320 [8.13] Mated Height		.390 [9.91] Mated Height			
		Tubes	Tape & Reel*		Tubes	Tape & Reel*	Tubes		Tape & Reel*	
		Hold Down	No Hold Down			Hold Down	No Hold Down			
10	9.44 [.372]	5-104655-1	5-147381-1	5-147121-1	5-104656-1	5-147382-1	5-104693-1	—	5-147383-1	
20	15.79 [.622]	5-104655-3	5-147381-2	5-147121-2	5-104656-2	5-147382-2	5-104693-2	—	5-147383-2	
30	22.14 [.872]	5-104655-4	5-147381-3	—	5-104656-3	5-147382-3	5-104693-3	—	5-147383-3	
40	28.49 [1.122]	5-104655-5	5-147381-4	—	5-104656-4	5-147382-4	5-104693-4	—	5-147383-4	
50	34.84 [1.372]	5-104655-6	5-147381-5	—	5-104656-5	5-147382-5	5-104693-5	—	5-147383-5	
60	41.19 [1.622]	5-104655-7	5-147381-6	—	5-104656-6	5-147382-6	5-104693-6	—	5-147383-6	
70	47.54 [1.872]	5-104655-8	5-147381-7	—	5-104656-7	5-147382-7	5-104693-7	—	5-147383-7	
80	53.89 [2.122]	5-104655-9	5-147381-8	—	5-104656-8	5-147382-8	5-104693-8	—	5-147383-8	
90	60.24 [2.372]	—	—	—	5-104656-9	—	5-104693-9	—	—	
100	66.59 [2.622]	6-104655-1	5-147381-9	—	6-104656-0	5-147382-9	6-104693-0	5-147503-1	5-147383-9	

*Parts packaged in tape and reel have vacuum pick and place cover. See PC Board Layout on page 93.

Note: Part Numbers are RoHS compliant.

1.27mm AMPMODU 50/50 Grid Connectors

Recommended PC Board Layouts for Vertical Connectors

Receptacles

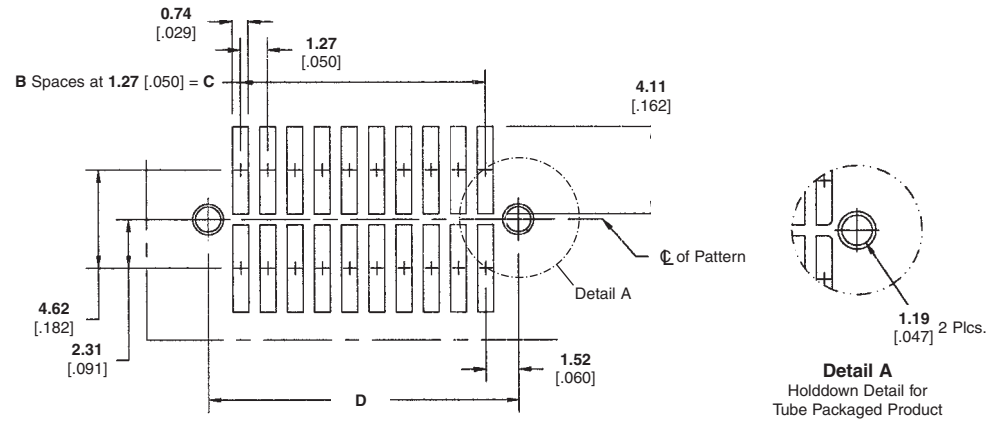

Headers

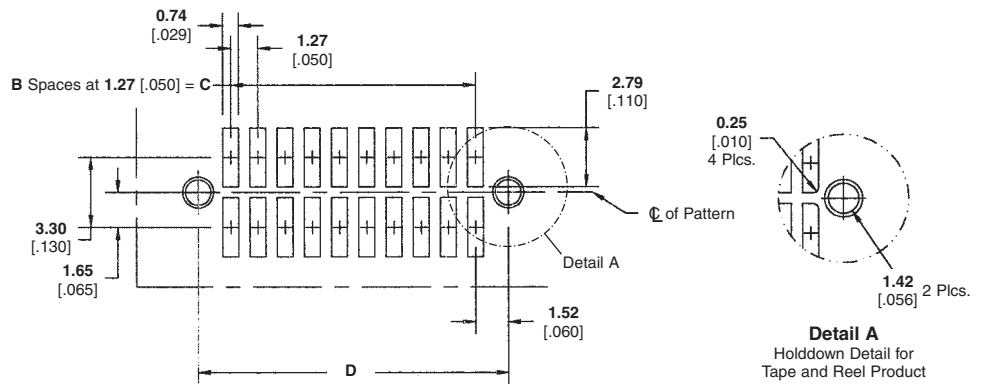

No. of Pos.	Receptacle Dimensions			Header Dimensions		
	B	C	D	B	C	D
10	4	5.08 [.200]	8.12 [.320]	4	5.08 [.200]	8.17 [.322]
20	9	11.43 [.450]	14.48 [.570]	9	11.43 [.450]	14.52 [.572]
30	14	17.78 [.700]	20.83 [.820]	14	17.78 [.700]	20.87 [.822]
40	19	24.13 [.950]	27.19 [1.070]	19	24.13 [.950]	27.22 [1.072]
50	24	30.48 [1.200]	33.53 [1.320]	24	30.48 [1.200]	33.57 [1.322]
60	29	36.83 [1.450]	39.88 [1.570]	29	36.83 [1.450]	39.92 [1.572]
70	34	43.18 [1.700]	46.23 [1.820]	34	43.18 [1.700]	46.27 [1.822]
80	39	49.53 [1.950]	52.58 [2.070]	39	49.53 [1.950]	52.62 [2.072]
90	44	55.88 [2.200]	58.93 [2.320]	44	55.88 [2.200]	58.97 [2.322]
100	49	62.23 [2.450]	65.28 [2.570]	49	62.23 [2.450]	65.32 [2.572]

Note: Refer to Tyco Electronics Customer Drawings for additional PC board layout information and dimensional tolerances.

Board-to-Board Right Angle Headers

Product Facts

- Surface-mount products for right angle board-to-board and cable-to-board applications
- Dual-row, right angle shrouded headers
- High density 1.27 x 1.27 [.050 x .050] centerline grid
- Latching and non-latching versions available
- Non-protrusive metallic holddowns
- Metallic tabs, when soldered to PC board pad, provide added mechanical support
- Duplex plated post contacts; gold plated on mating area, tin plated on tails
- Compatible with standard surface-mount processing (VPR and IR)
- Standoffs on header housings allow for drainage of processing fluids
- All headers are polarized
- Sizes of 10, 20, 30, 40, 50, 60, 70, 80 and 100 positions
- Recognized under the Component Program of Underwriters Laboratories Inc., File No. E28476
- Certified by Canadian Standards Association File No. LR7189



AMPMODU 50/50 Grid Right Angle Headers will accommodate a variety of high density packaging applications; right angle board-to-board applications when mated with vertical receptacles (page 91) and right angle cable-to-board applications when mated with cable connectors (page 97). The small 1.27 x 1.27 [.050 x .050] centerline contact spacing allows efficient use of the PC board area.

Mechanical support of the headers to the PC board is provided by non-protrusive metallic holddowns designed for 1.57 [.062] or thicker PC boards. These holddowns are of the same

design as those used in the vertical headers (page 92) and receptacles (page 91). There are also metallic tabs that are soldered to the surfaces of the PC board pads for added support.

AMPMODU 50/50 Grid Right Angle Headers are available in dual-row, in either latching or non-latching versions, and in sizes ranging from 10 through 100 positions (in 10 position increments). The latching version provides positive retention when mated with the latching cable connector (page 97). All headers feature polarization to help prevent misalignment during mating.

See Catalog 1307819 for additional AMPMODU product offerings.

1.27mm AMPMODU 50/50 Grid Connectors

**Board-to-Board Right Angle Headers, Dual-Row, 1.27 x 1.27
[.050 x .050] Centerline**

Non-Latching Header

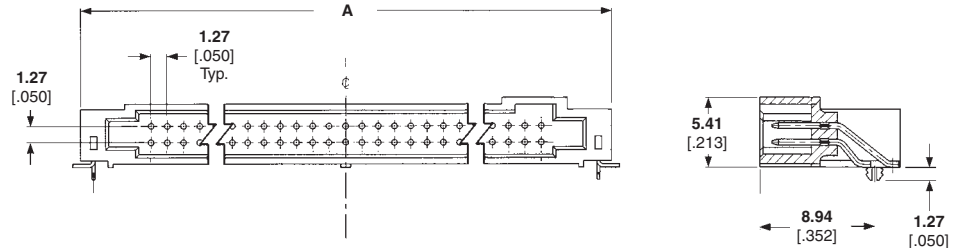

Latching Header

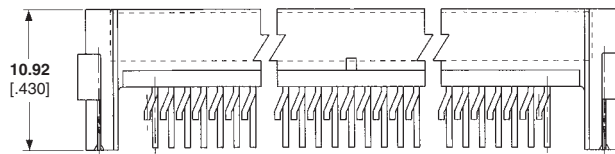

Material and Finish

Housing — Liquid crystal polymer, black, 94V-0 rated

Contacts — Brass; duplex plated 0.00076 [.000030] gold in mating area, 0.000381 [.000150] tin on solder tail, with entire contact underplated 0.00127 [.000050] nickel

Holddown — Copper alloy; plated 0.00381 [.0000150] tin over 0.00127 [.000050] nickel

Related Product Data

Mating Receptacles — pages 91, 97

Technical Documents (page 113)

Product Specification 108-1443

Application Specification 114-7010

Packaging: Tube

Note: Refer to Tyco Electronics Customer Drawings for additional PC board layout information and dimensional tolerances.

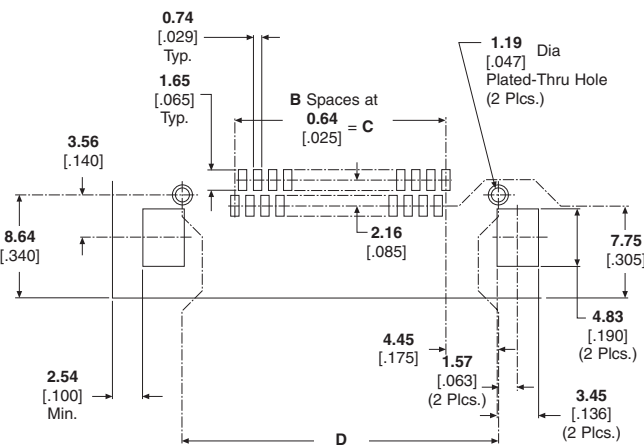

Recommended PC Board Layout

1.27mm AMPMODU 50/50 Grid Connectors



1.27mm AMPMODU 50/50 Grid Connectors

No. of Pos.	Dimensions				Header Part Numbers	
	A	B	C	D	Latching	Non-Latching
10	16.00 [.630]	9	5.72 [.225]	13.97 [.550]	5-104895-1	5-104894-1
20	22.35 [.880]	19	12.07 [.475]	20.32 [.800]	5-104895-2	5-104894-2
30	28.70 [1.130]	29	18.42 [.725]	26.67 [1.050]	5-104895-3	5-104894-3
40	35.05 [1.380]	39	24.77 [.975]	33.02 [1.300]	5-104895-4	5-104894-4
50	41.40 [1.630]	49	31.12 [1.225]	39.37 [1.550]	5-104895-5	5-104894-5
60	47.75 [1.880]	59	37.47 [1.475]	45.72 [1.800]	5-104895-6	5-104894-6
70	54.10 [2.130]	69	43.82 [1.725]	52.07 [2.050]	5-104895-7	5-104894-7
80	60.45 [2.380]	79	50.17 [1.975]	58.42 [2.300]	5-104895-8	5-104894-8
100	73.15 [2.880]	99	62.87 [2.475]	71.12 [2.800]	6-104895-0	6-104894-0

Note: Part Numbers are RoHS compliant.

Cable-to-Board Connectors

Product Facts

- Dual-row receptacle connectors provide cable-to-board connection capabilities for vertical headers (non-latching) and right angle headers (latching and non-latching)
- IDC (Insulation Displacement Crimp) mass termination of solid or stranded round conductor 1.27 [.050] centerline ribbon cable with PVC or polyethylene insulation
- Accommodates ribbon cable conductor sizes of 28 AWG [0.08-0.09 mm²] and 30 AWG [0.05 mm²] and insulation diameters up to 0.91 [.036] maximum
- Reliable single beam receptacle contact design
- Duplex plated receptacle contacts; gold plated in mating area, bright tin-lead in termination area
- Terminating covers (sold separately) provide both strain relief and protection to the termination area
- Sizes of 10, 20, 30, 40, 50, 60, 70, 80 and 100 positions
- Connectors available with or without metal latch
- Connectors without latches are polarized to help prevent mismatching
- Recognized under the Component Program of Underwriters Laboratories Inc., File No. E28476 
- Certified by Canadian Standards Association File No. LR7189 

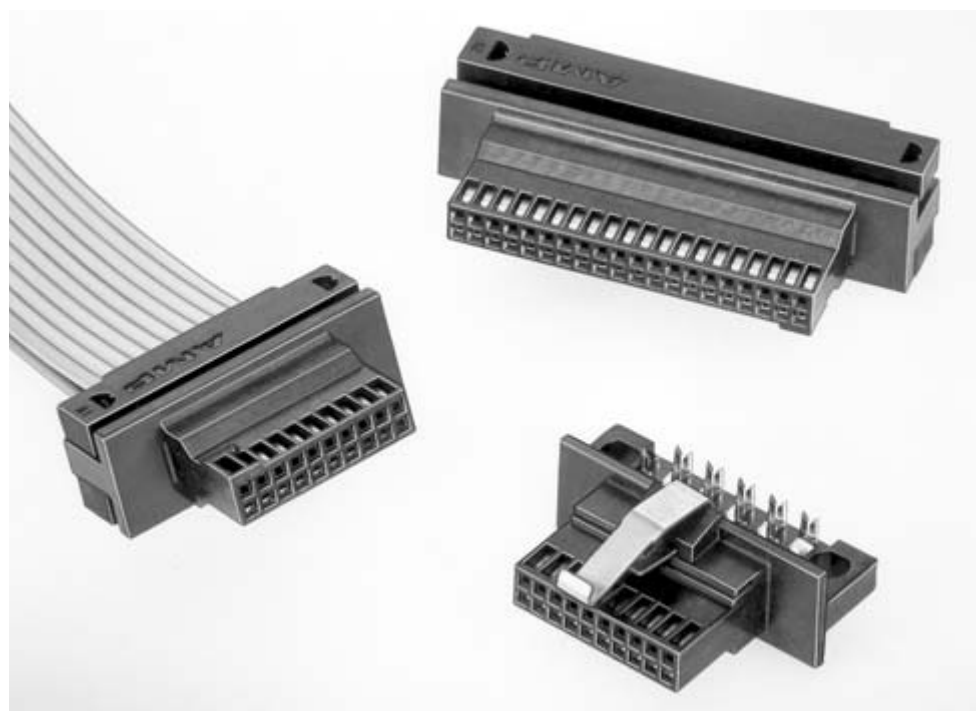

These dual-row cable connectors, with a 1.27 x 1.27 [.050 x .050] centerline contact spacing, provide cable-to-board connection capabilities for the AMPMODU 50/50 Grid Connector System. Cable connectors without a latch will mate with the vertical headers (page 92), while cable connectors with or without a latch can be used to mate with the right angle headers (page 95).

The cable connectors feature reliable single-beam IDC (insulation displacement crimp) contacts which are duplex plated with

0.00076 [.000030] gold. These contacts can be mass terminated to either solid or stranded round conductor ribbon cable with conductor sizes of 28 AWG [0.08-0.09 mm²] and 30 AWG [0.05 mm²] and a maximum insulation diameter of 0.91 [.036]. During termination, the terminating covers, which must be purchased separately, assist in guiding the wire into the IDC contacts, then provide strain relief when fully seated. Actual termination is accomplished with the Tyco Electronics manual tooling shown on page 99.

The latching version of the cable connector is equipped with a metal latch which provides positive retention of the receptacle cable connector when mated with a surface-mounted right angle header. The cable connector without a metal latch features polarization to help prevent mismatching. All connectors are available in sizes ranging from 10 through 100 positions (in 10 position increments).

See Catalog 1307819 for additional AMPMODU product offerings.

1.27mm AMPMODU 50/50 Grid Connectors

**Cable-to-Board Receptacle Connectors, Dual-Row, 1.27 x 1.27
[.050 x .050] Centerline**

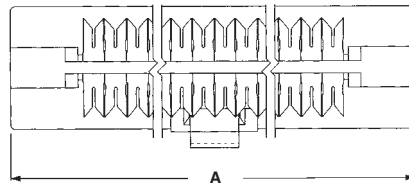

Material and Finish

Housing — Thermoplastic, black, 94V-0 rated

Latch — Stainless steel

Contacts — Phosphor bronze; duplex plated 0.00076 [.000030] minimum gold in mating area, 0.00381 [.000150] minimum tin in termination area, with entire contact underplated 0.00127 [.000050] minimum nickel

Related Product Data

Mating Headers — pages 92, 95 (latching)

Terminating Covers (Must be Purchased Separately, 2 Required per Connector) — page 98

Termination Tooling — page 99

Technical Documents (page 113)

Product Specification 108-1443

Application Specification 408-9817, 408-9909

Packaging: Tube

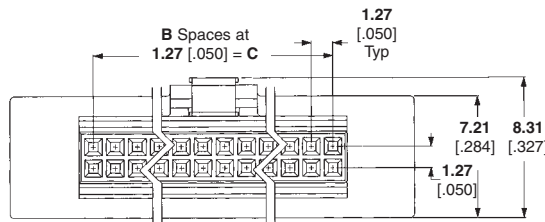
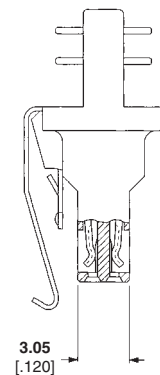
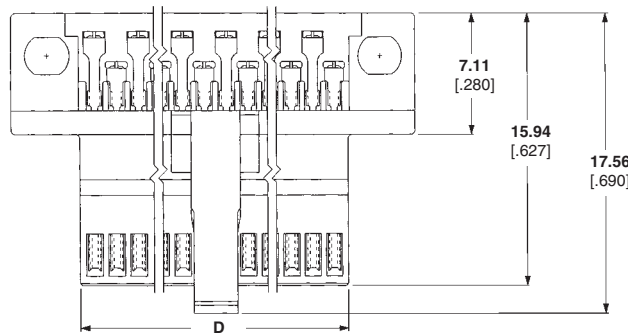

No. of Pos.	Dimensions				Receptacle Part Numbers	
	A	B	C	D	With Latch	Without Latch
10	14.68 [.578]	4	5.08 [.200]	6.76 [.266]	5-104892-1	5-104893-1
20	21.03 [.828]	9	11.43 [.450]	13.11 [.516]	5-104892-2	5-104893-2
30	27.38 [1.078]	14	17.78 [.700]	19.46 [.766]	5-104892-3	5-104893-3
40	33.73 [1.328]	19	24.13 [.950]	25.81 [1.016]	5-104892-4	5-104893-4
50	40.08 [1.578]	24	30.48 [1.200]	32.16 [1.266]	5-104892-5	5-104893-5
60	46.43 [1.828]	29	36.83 [1.450]	38.51 [1.516]	5-104892-6	5-104893-6
70	52.78 [2.078]	34	43.18 [1.700]	44.86 [1.766]	5-104892-7	5-104893-7
80	59.13 [2.328]	39	49.53 [1.950]	51.21 [2.016]	5-104892-8	5-104893-8
100	71.83 [2.828]	49	62.23 [2.450]	63.91 [2.516]	6-104892-0	6-104893-0

Note: Part Numbers are RoHS compliant.

1.27mm AMPMODU 50/50 Grid Connectors

1.27mm AMPMODU 50/50 Grid Connectors

Terminating Covers for Cable Connectors



Material

Glass-filled thermoplastic,
black, 94V-0 rated

Related Product Data

Connectors used with Covers —
page 97

Termination Tooling — page 99

Technical Documents (page 113)

Product Specification 108-1443

Application Specification
408-9817, 408-9909

Packaging: Plastic bag

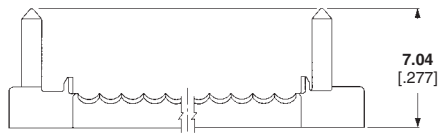
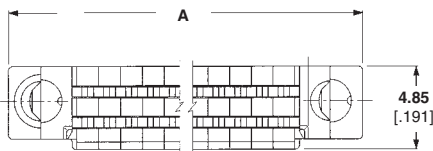

No. of Pos.	Dimension A	Terminator Cover Part Numbers
10	14.35 [.565]	104891-1
20	20.70 [.815]	104891-2
30	27.05 [1.065]	104891-3
40	33.82 [1.315]	104891-4
50	39.75 [1.565]	104891-5
60	46.10 [1.815]	104891-6
70	52.45 [2.065]	104891-7
80	58.80 [2.315]	104891-8
100	71.50 [2.815]	1-104891-0

Notes: Terminating covers must be purchased separately, two are required for each cable connector.
Part Numbers are RoHS compliant.

Application Tooling for Cable Connectors

The Tyco Electronics Manual Miniature Application Frame Assembly 91295-1, equipped with a Cover Closing Kit 543518-1, is used for the IDC termination of ribbon cable to the cable connectors shown on page 97.

Prior to termination, the covers must be partially assembled onto a connector housing, the cable inserted between the covers and contacts and the covers preclosed by hand, clamping the cable in place.

In the Manual Miniature Application Frame Assembly, the covers are fully seated to complete the mass termination and provide strain relief for the completed connection.

For tooling information, call Technical Support at the numbers listed below.



Manual Miniature Application Frame Assembly 91295-1 with Cover Closing Kit 543518-1

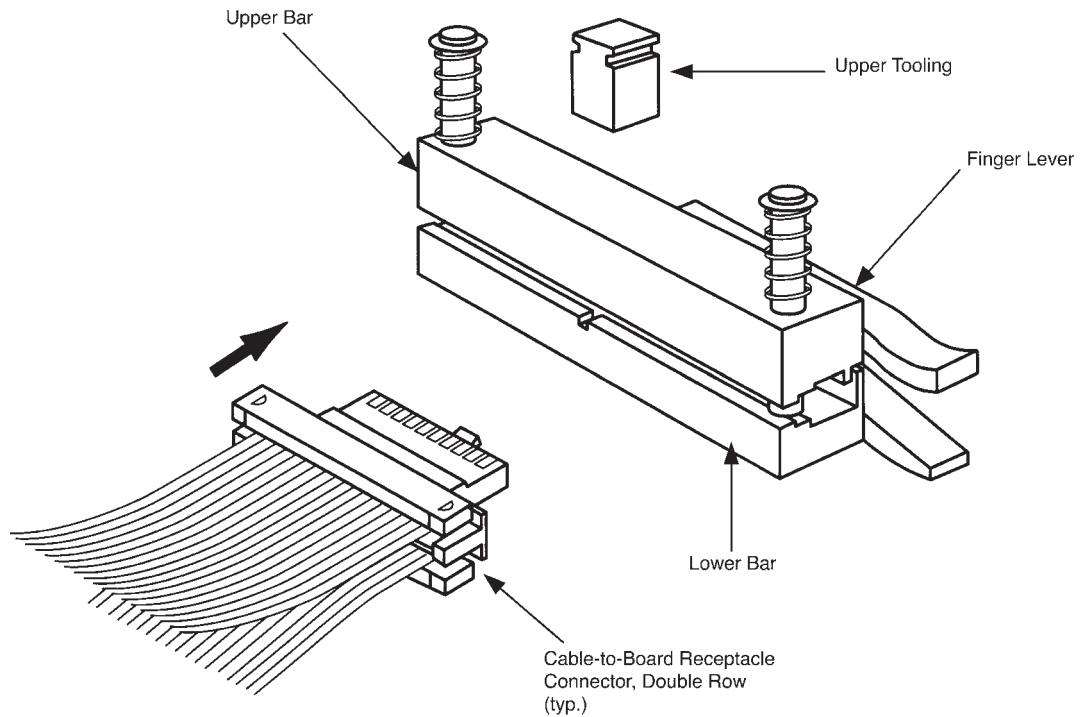

Note: Refer to Tyco Electronics Instruction Sheets 408-9817 (Frame Assembly 91295-1) and 408-9909 (Cover Closing Kit 543518-1) for complete termination/tooling information.

1.27mm AMPMODU 50/50 Grid Connectors

1.27mm AMPMODU 50/50 Grid Connectors

Engineering Notes

