

PART NUMBER	REV	FIRST USED
1385040-1	B	122500-1
1385040-2	B	565435-5
1385040-3	B	354500-1

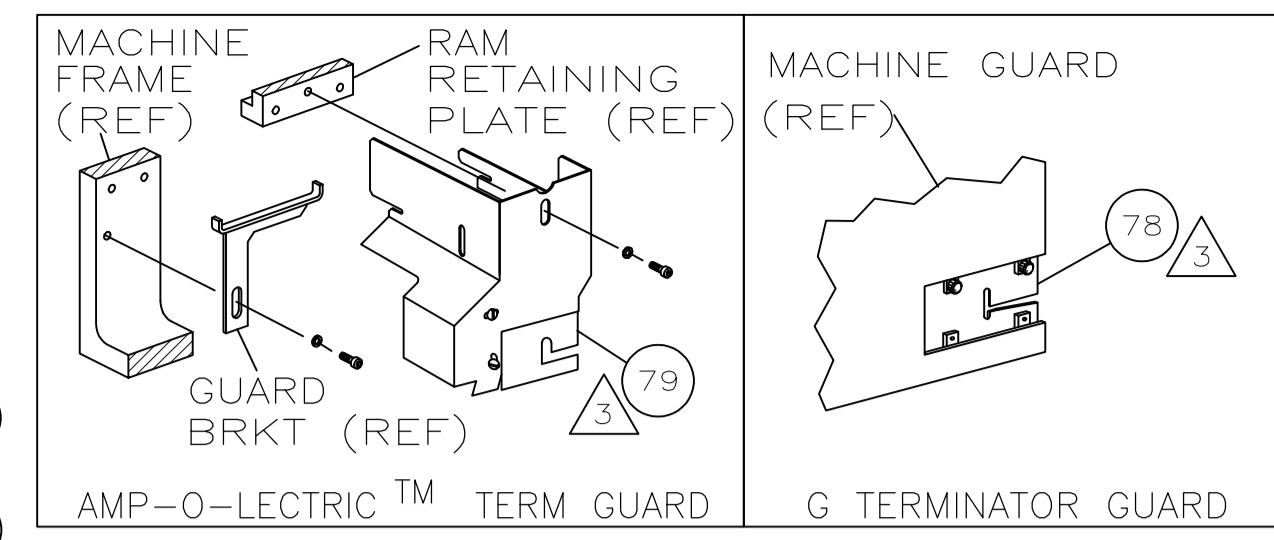

AMP P/N		MFG P/N		CRIMP DATA (NON-AMP TERMINAL-AMP SPEC)		
286861-1	SYM-001T-P0.6			PAD LTR	CRIMP HEIGHT	WIRE SIZE
286861-2	SYF-001T-P0.6			A	.037 ±.002 [0.94 ±0.05mm]	22
				B	.035 ±.002 [0.89 ±0.05mm]	24
				C	.033 ±.002 [0.84 ±0.05mm]	26
				D	.032 ±.002 [0.81 ±0.05mm]	28
				CRIMP	SIZE	TYPE
				WIRE	.055 [1.40mm]	F
				INSUL	.070 [1.78mm]	F
						7
WIRE STRIP LENGTH	TERM APPL SPEC	FEED	APPL INSTRUCTION	SET UP GAGE	LAYOUT	
.099-.125	NONE	.299	408-8040	458637-1	L2350	

LOC	DIST	REVISIONS			
A	66	REV	DESCRIPTION	DATE	BY
		B1	ECR-08-006960	3-2008	MY

-1	LEADMAKER	MECH POST FEED
-2	BENCH MODEL K	MECH PRE FEED
-3	BENCH MODEL G	MECH PRE FEED

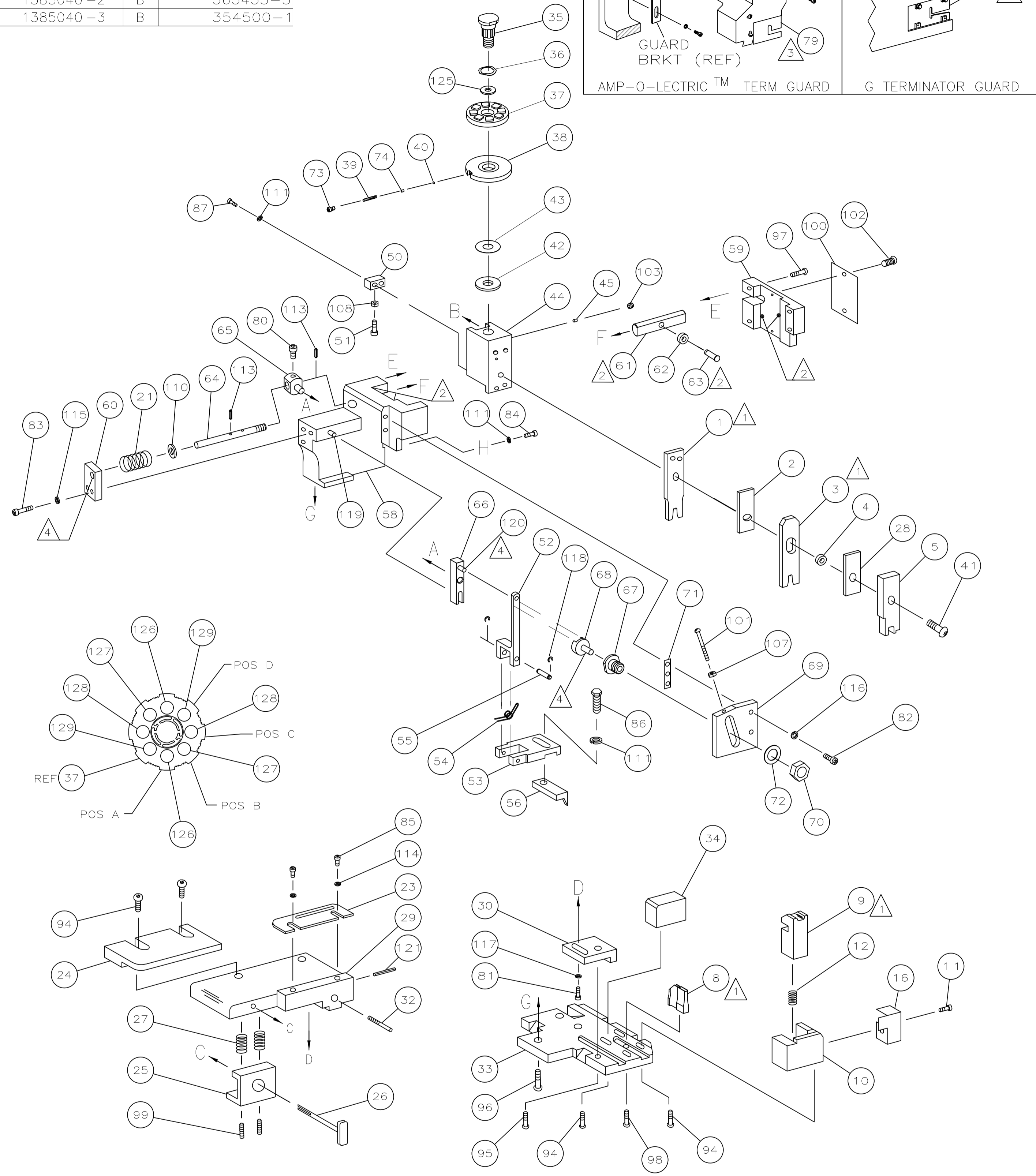

2	2	2	-	5-354779-8	PIN, WIRE DISC (.3280)D	129
2	2	2	-	5-354779-6	PIN, WIRE DISC (.3270)C	128
2	2	2	-	5-354779-2	PIN, WIRE DISC (.3250)B	127
2	2	2	-	4-354779-8	PIN, WIRE DISC (.3230)A	126
1	1	1	-	986950-1	WASHER, FLAT PRECISION	125
1	1	1	-	217238-1	GENERAL INSTRUCTION PACKAGE	124
1	1	1	-	4088040	SF APPL INST 408-8040	123
						122
1	1	1	-	4-21028-0	PIN,SLT SPR(Ø.093x.75)ST GDE PL	121
REF	REF	REF	-	1-21030-1	PIN,DOWEL(Ø.187x.50)LEVER	120
REF	REF	REF	-	1-21030-6	PIN,DOWEL(Ø.187x1.25)HOUSING	119
REF	REF	REF	-	21045-3	RING,RET "C"(Ø.187)FD FING PIN	118
1	1	1	-	21024-5	WASHER, LOCK(#10)ADJ BLOCK	117
REF	REF	REF	-	21024-5	WASHER,LOCK(#10)ADJ PLATE	116
REF	REF	REF	-	21024-5	WASHER,LOCK(#10)FEED GDE ROD	115
2	2	2	-	21024-2	WASHER,LOCK(#4)FRONT STP GUIDE	114
REF	REF	REF	-	5-21028-1	PIN,SLT SPR(Ø.125x.50)ADJ ROD	113
						112
4	4	4	-	21024-4	WASHER,LOCK(#8)STRIPPER	111
REF	REF	REF	-	21899-4	WASHER,FLAT(Ø5/16)SCREW ADJ	110
						109
1	1	1	-	21018-5	NUT,HEX(NO.6)HOLDDOWN	108
REF	REF	REF	-	21068-5	NUT,HEX(6-32)FEED ADJ	107
						106
						105
						104
1	1	1	-	21009-2	SCR,SKT SET(1/4-20x.25 LW)RAM	103
2	2	2	-	21017-2	SCR,DRIVE(#2x.19)ID PLATE	102
REF	REF	REF	-	6-23715-5	SCR,PAN HD(6-32x1.50)FEED ADJ	101
1	1	1	-	461264-1	PLATE, IDENTIFICATION	100
2	2	2	-	5-21006-6	SCR,SET(10-32x.75)DRAG	99
1	1	1	-	22733-8	SCR,BHC(8-32x.38 LW)ANVIL	98
REF	REF	REF	-	2-21002-9	SCR,BHC(10-32x.75)CAP	97
REF	REF	REF	-	2-22733-8	SCR,BHC(1/4-20x.62)HOUSING	96
REF	REF	REF	-	2-21002-7	SCR,BHC(10-32x.50)SG ADJ BLOCK	95
6	6	6	-	2-21002-2	SCR,BHC(8-32x.50)TERM H DWN	94
						93
						92
1	1	1	-	1-21002-7	SCR,BHC(6-32x.38)CAM	91
						90
						89
						88
2	2	2	-	2-21000-7	SCR,SHC(8-32x.48)DEP-HOLD	87
1	1	1	-	2-22603-0	SCR,HEX HD(8-32x.31)FEED FINGER	86
2	2	2	-	1-21000-3	SCR,SHC(4-40x.25)F ST GUIDE	85
1	1	1	-	2-21000-7	SCR,SHC(8-32x.50)STRIPPER	84
REF	REF	REF	-	3-21000-7	SCR,SHC(10-32x.75)FEED ROD GD	83
REF	REF	REF	-	3-21000-6	SCR,SHC(10-32x.62)FD ADJ BLK	82
1	1	1	-	3-21000-4	SCR,SHC(10-32x.38)SG ADJ BL	81
REF	REF	REF	-	3-21000-4	SCR,SHC(10-32x.38)PIVOT BLK	80
-	REF	-	-	455749-1	GUARD, WINDOW	79
REF	-	-	-	679532-1	INSERT, GUARD	78
						77
						76
						75
1	1	1	-	690603-1	SPRING, ASSIST	74
1	1	1	-	23030-1	SCR,SHC(6-32x.25 SL)INS DISC	73
REF	REF	REF	-	458109-1	WASHER, SPECIAL	72
REF	REF	REF	-	690517-1	SPACER	71
-3	-2	-1	U/M	PART NO	DESCRIPTION	ITEM NO
					PARTS LIST	
QTY	REQD	PER	ASSY			

REF	REF	REF	-	22594-8	NUT,HEX(1/2-20)	70
REF	REF	REF	-	240628-1	PLATE, ADJUSTMENT	69
REF	REF	REF	-	240626-1	SHAFT, PIVOT	68
REF	REF	REF	-	240633-1	BUSHING	67
REF	REF	REF	-	455680-1	LEVER, INTERMEDIATE	66
REF	REF	REF	-	240629-1	BLOCK, PIVOT	65
REF	REF	REF	-	240632-2	SCREW, ADJ FEED ROD	64
REF	REF	REF	-	240659-3	PIN, CAM ROLLER	63
REF	REF	REF	-	240658-1	ROLLER, CAM	62
REF	REF	REF	-	454398-2	ROD, FEED	61
REF	REF	REF	-	454178-1	GUIDE, FEED ROD	60
REF	REF	REF	-	454220-1	CAP, RAM	59
REF	REF	REF	-	454485-1	HOUSING	58
						57
1	1	1	-	458537-2	PAWL, FEED	56
REF	REF	REF	-	240624-1	PIN, FEED FINGER	55
REF	REF	REF	-	691499-1	SPRING, FEED FINGER	54
REF	REF	REF	-	690541-1	HOLDER, FEED FINGER	53
REF	REF	REF	-	455679-1	LEVER, TERMINAL FEED ARM	52
1	1	1	-	811242-2	BUMPER, HOLDDOWN	51
1	1	1	-	690753-1	SPACER, TONKER	50
1	-	-	-	690602-6	CAM, PRE-FEED 1 5/8 ST	49
-	1	-	-	690602-5	CAM, PRE-FEED 1 1/8 ST	48
-	-	1	-	690501-4	CAM, POST-FEED 1 5/8 ST	47
1	1	1	-	459456-1	APPLICATOR, BASIC (SUBASSY)	46
1	1	1	-	690191-1	PLUG, NYLON	45
1	1	1	-	455673-3	RAM	44
1	1	1	-	690125-1	WASHER, LAMINATED	43
1	1	1	-	690124-1	WASHER, RAM	42
1	1	1	-	7-21002-9	BOLT, CRIMPER(5/16x1.00)	41
1	1	1	-	23241-6	BALL, STEEL	40
1	1	1	-	690170-1	SPRING, COMPRESSION	39
1	1	1	-	690142-1	DISC, INSULATION	38
1	1	1	-	354777-1	WIRE DISC, PLASTIC	37
1	1	1	-	22480-5	WASHER, SPRING	36
1	1	1	-	690212-1	POST, RAM	35
1	1	1	-	690786-1	SUPPORT, TERMINAL	34
REF	REF	REF	-	455675-1	PLATE, BASE	33
1	1	1	-	690432-3	SCREW, ADJUSTMENT	32
						31
REF	REF	REF	-	455689-1	BLOCK, STRIP GUIDE ADJ	30
1	1	1	-	455671-6	PLATE, STRIP GUIDE	29
1	1	1	-	455888-8	SPACER, FRONT SHEAR DEP	28
2	2	2	-	1-22284-0	SPRING, DRAG	27
1	1	1	-	690546-1	LEVER, DRAG RELEASE	26
1	1	1	-	240792-1	DRAG, TERMINAL	25
1	1	1	-	5-690504-9	GUIDE, STRIP (REAR)	24
1	1	1	-	690438-1	GUIDE, STRIP (FRONT)	23
-	-	1	-	690472-2	STRIPPER	22
REF	REF	REF	-	4-22284-9	SPRING, FEED RETURN	21
						20
1	1	-	-	691353-1	STRIPPER	19
						18
						17
1	1	1	-	318563-1	GUARD, CHIP, FRONT	16
						15
						14
						13
1	1	1	-	3-22280-3	SPRING, SHEAR	12
1	1	1	-	690461-1	STOP, SHEAR	11
1	1	1	-	690459-1	HOLDER, SHEAR (FRONT)	10
1	1	1	-	462006-1	SHEAR, FLOAT (FRONT)	9
1	1	1	-	2-805887-4	ANVIL	8
						7
						6
1	1	1	-	2-455889-0	DEPRESSOR, SHEAR (FRONT)	5
1	1	1	-	238011-6	SPACER, BLOCK CRIMPER	4
1	1	1	-	3-683453-3	CRIMPER, INSULATION	3
1	1	1	-	455888-2	SPACER, CRIMPER	2
1	1	1	-	2-456402-9	CRIMPER, WIRE	1
-3	-2	-1	U/M	PART NO	DESCRIPTION	ITEM NO
					PARTS LIST	
QTY	REQD	PER	ASSY			

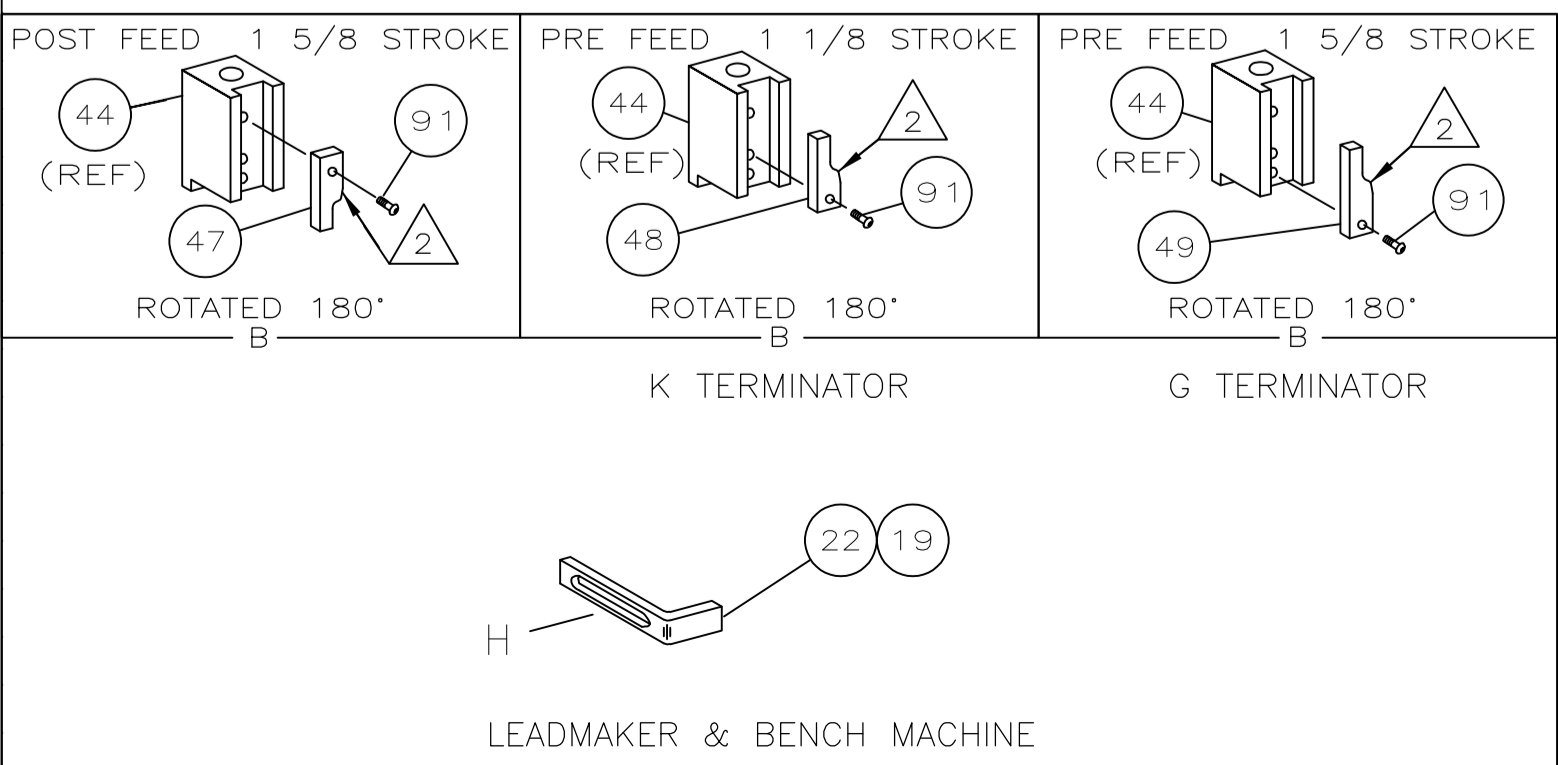

- 1 RECOMMENDED SPARE PARTS.
- 2 GREASE LIGHTLY.
- 3 GUARD MUST BE IN PLACE WHEN OPERATING APPLICATOR IN A BENCH MACHINE.
- 4 LUBRICATE DAILY USING NO. 20 MACHINE OIL.
- 5. ITEMS WITH QTY OF REF SPECIFIED (EXCEPT ITEMS 78 AND 79) ARE USED ON ITEM 46.
- 6 CUT TO LENGTH AT ASSY
- 7 TO BE DETERMINED AT ASSEMBLY.

DIMENSIONS:		TOLERANCES UNLESS OTHERWISE SPECIFIED:		APPROVED:		CUSTOMER DRAWING	
INCHES:		0.125	±.005	DATE:	13MAR00	SCALE:	1:1
		0.250	±.010	BY:	B. HIGMAN	SHEET:	1 of 1
		0.375	±.015	CHK:	B. HIGMAN	REV:	
		0.500	±.020	APPD:	J. ELBIN		
		0.625	±.025	NAME:			
		0.750	±.030				
		0.875	±.035				
		1.000	±.040				
		1.125	±.045				
		1.250	±.050				
		1.375	±.055				
		1.500	±.060				
		1.625	±.065				
		1.750	±.070				
		1.875	±.075				
		2.000	±.080				
		2.125	±.085				
		2.250	±.090				
		2.375	±.095				
		2.500	±.100				
		2.625	±.105				
		2.750	±.110				
		2.875	±.115				
		3.000	±.120				
		3.125	±.125				
		3.250	±.130				
		3.375	±.135				
		3.500	±.140				
		3.625	±.145				
		3.750	±.150				
		3.875	±.155				
		4.000	±.160				
		4.125	±.165				
		4.250	±.170				
		4.375	±.175				
		4.500	±.180				
		4.625	±.185				
		4.750	±.190				