

Sensor/actuator box - SACB-8/16-L- 5,0HPUR SCO - 1517301

Please be informed that the data shown in this PDF Document is generated from our Online Catalog. Please find the complete data in the user's documentation. Our General Terms of Use for Downloads are valid (<http://phoenixcontact.com/download>)



Sensor/actuator box, Application: Standard, Connection method: M12-SPEEDCON-socket Metal, Number of slots: 8, Number of positions: 5, Coding: A - standard, Slot assignment: Double, Status indication: Yes, pnp; Master cable connection: Fixed connection 180°, PUR halogen free, Cable length: 5 m, Shielding: No

Why buy this product

- Safety in the field, thanks to molded housing and high degree of protection
- Flexible, distributed bundling of signals in one master cable
- Convenient: increased machine availability thanks to quick and easy diagnostics
- Save space: distributor box with double occupancy for two sensors in one slot
- Save time, thanks to installation with SPEEDCON fast locking system



Key Commercial Data

Packing unit	1 STK
GTIN	 4 017918 967970
GTIN	4017918967970
Weight per Piece (excluding packing)	1,278.700 g
Custom tariff number	85444290
Country of origin	Poland

Technical data

General

Rated voltage	24 V DC
Max. operating voltage U_{max}	30 V DC
Current carrying capacity per I/O signal	2 A
Current carrying capacity per slot	4 A
Total rated current	12 A

Sensor/actuator box - SACB-8/16-L- 5,0HPUR SCO - 1517301

Technical data

General

Number of positions	5
Number of slots	8
Flammability rating according to UL 94	V0
Sensor/actuator connection system	M12-SPEEDCON-socket

Ambient conditions

Degree of protection	IP65
	IP67
	IP69K
Ambient temperature (operation)	-30 °C ... 90 °C
	-40 °C ... 90 °C (for fixed installation)
	-5 °C ... 80 °C (for flexible installation)

Local diagnostics function

Local diagnostics	Supply voltage Green LED
	Status display I/O Yellow LED

Master cable connection data

Connection method	Fixed connection
Length of cable	5 m
Tightening torque slot sensor/actuator cable	0.4 Nm
Tightening torque of mounting screw for fixing the housing	0.5 Nm

Insulation material

Housing material	PBT
Material of the moulding mass	PUR
Contact material	Cu alloy
Contact surface material	gold-plated
Contact carrier material	PA
Material of threaded sleeve	Zinc die-cast
Material of threaded sleeve surface	Nickel-plated
O-ring material	NBR

Pin assignment

Slot/position = Wire color or connection	1 / 4 (A) = WH
	1 / 2 (B) = GY/PK
	2 / 4 (A) = GN
	2 / 2 (B) = RD/BU
	3 / 4 (A) = YE
	3 / 2 (B) = WH/GN

Sensor/actuator box - SACB-8/16-L- 5,0HPUR SCO - 1517301

Technical data

Pin assignment

	4 / 4 (A) = GY
	4 / 2 (B) = BN/GN
	5 / 4 (A) = PK
	5 / 2 (B) = WH/YE
	6 / 4 (A) = RD
	6 / 2 (B) = YE/BN
	7 / 4 (A) = BK
	7 / 2 (B) = WH/GY
	8 / 4 (A) = VT
	8 / 2 (B) = GY/BN
	1-8 / 1 (+ 24 V) = BN
	1-8 / 3 (0 V) = BU
	1-8 / 5 (PE) = GN/YE

Standards and Regulations

Standard designation	M12 connector
Standards/regulations	IEC 61076-2-101
Connection in acc. with standard	CUL
Flammability rating according to UL 94	V0

Cable

Cable type	PUR halogen-free black
Cable type (abbreviation)	PUR
Cable abbreviation	Li9Y11Y-HF
Conductor cross section	16x 0.5 mm ² (Signal line)
	3x 1 mm ² (power line)
AWG signal line	20
AWG power supply	17
Conductor structure signal line	64x 0.10 mm
Conductor structure, voltage supply	128x 0.10 mm
Overall twist	Wires twisted in layers
External sheath, color	black RAL 9005
External cable diameter D	11.6 mm ±0,3 mm
Smallest bending radius, fixed installation	116 mm
Smallest bending radius, movable installation	116 mm
Number of bending cycles	1500000
Bending radius	116 mm
Traversing path	2 m

Sensor/actuator box - SACB-8/16-L- 5,0HPUR SCO - 1517301

Technical data

Cable

Traversing rate	2 m/s
Outer sheath, material	PUR
Material conductor insulation	PP
Conductor material	Bare Cu litz wires
Nominal voltage, cable	300 V
Test voltage, cable	2000 V
Special properties	Silicone-free
Flame resistance	DIN EN 50265
Resistance to oil	As per VDE 0472 Part 803
Other resistance	Highly resistant to acids, alkaline solutions and solvents
Ambient temperature (operation)	-40 °C ... 90 °C (cable, fixed installation)
	-5 °C ... 80 °C (cable, flexible installation)

Drawings

Schematic diagram

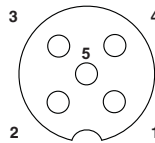

M12 slot, socket, 5-pos.

Cable cross section

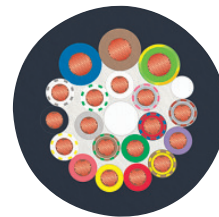

PUR halogen-free black [PUR]

Dimensional drawing

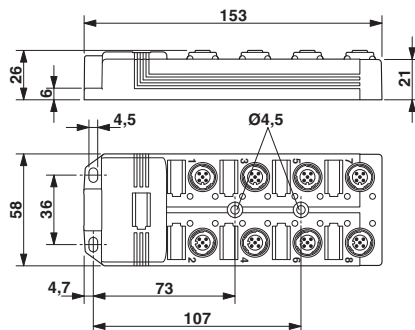

Circuit diagram

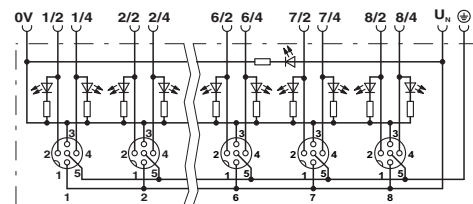

Sensor/actuator box - SACB-8/16-L- 5,0HPUR SCO - 1517301

Classifications

eCl@ss

eCl@ss 4.0	27140815
eCl@ss 4.1	27140815
eCl@ss 5.0	27143423
eCl@ss 5.1	27143423
eCl@ss 6.0	27143423
eCl@ss 7.0	27449001
eCl@ss 8.0	27279219
eCl@ss 9.0	27440108

ETIM

ETIM 2.0	EC000200
ETIM 3.0	EC001856
ETIM 4.0	EC002585
ETIM 5.0	EC002585
ETIM 6.0	EC002585

UNSPSC

UNSPSC 6.01	31261501
UNSPSC 7.0901	31261501
UNSPSC 11	31261501
UNSPSC 12.01	31261501
UNSPSC 13.2	31251501

Approvals

Approvals

Approvals

EAC / UL Recognized / cUL Recognized / cULus Recognized

Ex Approvals

Approval details

EAC		EAC-Zulassung
-----	---	---------------

Sensor/actuator box - SACB-8/16-L- 5,0HPUR SCO - 1517301

Approvals

UL Recognized		http://database.ul.com/cgi-bin/XYV/template/LISEXT/1FRAME/index.htm	FILE E 118976
Nominal current IN	3 A		
Nominal voltage UN	24 V		

cUL Recognized		http://database.ul.com/cgi-bin/XYV/template/LISEXT/1FRAME/index.htm	FILE E 118976
Nominal current IN	3 A		
Nominal voltage UN	24 V		

cULus Recognized		http://database.ul.com/cgi-bin/XYV/template/LISEXT/1FRAME/index.htm
------------------	--	---

Accessories

Accessories

Device marking

Contactor marker – zack marker strip - SS-ZB 17,5 WH - 0804963



Contactor marker – zack marker strip, Strip, white, unlabeled, can be labeled with: CMS-P1-PLOTTER, Mounting type: Snap into flat marker groove, Lettering field: 17.5 x 9 mm

Contactor marker – zack marker strip - SS-ZB 17,5 YE - 0804976



Contactor marker – zack marker strip, Strip, yellow, unlabeled, can be labeled with: CMS-P1-PLOTTER, Mounting type: Snap into flat marker groove, Lettering field: 17.5 x 9 mm

Labeled device marker

Sensor/actuator box - SACB-8/16-L- 5,0HPUR SCO - 1517301

Accessories

Contactor marker – zack marker strip - SS-ZB 17,5 WH CUS - 0824468



Contactor marker – zack marker strip, can be ordered: Strip, white, labeled according to customer specifications, Mounting type: Snap into flat marker groove, Lettering field: 17.5 x 9 mm

Contactor marker – zack marker strip - SS-ZB 17,5 YE CUS - 0824469



Contactor marker – zack marker strip, can be ordered: Strip, yellow, labeled according to customer specifications, Mounting type: Snap into flat marker groove, Lettering field: 17.5 x 9 mm

Mounting rail adapter

Electronic housing - UTA 136 - 2853996

Universal DIN rail adapter, for screwing on switchgear



Protective cap

Screw plug - PROT-MS SCO - 1553129



M12 screw plug with SPEEDCON quick locking for unoccupied M12 sockets of the sensor/actuator cables, boxes and flush-type connectors

Screwdriver tools

Sensor/actuator box - SACB-8/16-L- 5,0HPUR SCO - 1517301

Accessories

Adapter insert - TSD-M SAC-BIT ADAPTER - 1212600



Adapter bit for TSD-M...torque tools, E6.3-1/4" drive with 4 mm hexagon to accommodate SAC bits

Tool - SAC BIT M12-D15 - 1208432



Nut for assembling sensor/actuator cables with M12 connector and M12 connectors for assembly, with a knurl diameter of 15 mm, for 4 mm hexagonal drive

Tool - SACC BIT M12-D20 - 1208445



Nut for assembling M12 connectors for assembly with a knurl diameter of 20 mm, for 4 mm hexagonal drive

Torque tool

Torque screwdriver - TSD 04 SAC - 1208429



Torque screwdriver, with preset torque of 0.4 Nm and 4 mm hexagonal drive for M12 connectors

Torque screwdriver - TSD-M 1,2NM - 1212224



Torque screw driver, accuracy as per EN ISO 6789 standard, adjustable from 0.3 - 1.2 Nm

