

## Sensor/actuator box - SACB- 6/4-L- 5,0PUR QO-0,34 - 1548558

Please be informed that the data shown in this PDF Document is generated from our Online Catalog. Please find the complete data in the user's documentation. Our General Terms of Use for Downloads are valid (<http://phoenixcontact.com/download>)



Sensor/actuator box, Application: Standard, Connection method: QUICKON, 0.14 mm<sup>2</sup> ... 0.34 mm<sup>2</sup>, Number of slots: 6, Number of positions: 4, Slot assignment: Double, Status indication: Yes, pnp; Master cable connection: Fixed connection 180°, PUR/PVC, Cable length: 5 m, Shielding: No

The illustration shows a product version with 8 slots

### Why buy this product

- Safety in the field, thanks to molded housing and high degree of protection
- Flexible, distributed bundling of signals in one master cable
- Convenient: increased machine availability thanks to quick and easy diagnostics
- Save space: distributor box with double occupancy for two sensors in one slot
- Innovative and time-saving assembly with insulation displacement connection



### Key commercial data

Packing unit	1 pc
GTIN	 4 046356 142991
Weight per Piece (excluding packing)	908.09 g
Custom tariff number	85444290
Country of origin	Poland
Note	Made to Order (non-returnable)

### Technical data

#### General

Rated voltage	24 V DC
Max. operating voltage U <sub>max</sub>	30 V DC
Current carrying capacity per I/O signal	2 A
Current carrying capacity per slot	4 A
Total rated current	12 A
Number of positions	4
Number of slots	6
Inflammability class according to UL 94	V0

# Sensor/actuator box - SACB- 6/4-L- 5,0PUR QO-0,34 - 1548558

## Technical data

### General

Sensor/actuator connection system	QUICKON
-----------------------------------	---------

### Ambient conditions

Degree of protection	IP65
	IP67
	IP69K
Ambient temperature (operation)	-30 °C ... 80 °C
	-40 °C ... 90 °C (for fixed installation)
	-5 °C ... 80 °C (for flexible installation)

### Local diagnostics function

Local diagnostics	Supply voltage Green LED
	Status display I/O Yellow LED

### Master cable connection data

Connection method	Fixed connection
Length of cable	5 m
Tightening torque of mounting screw for fixing the housing	0.5 Nm

### Conductor data

Structure of individual litz in acc. with VDE 0295 / smallest wire diameter	Class 2-6
Wire insulation material	PVC/PE/PP
Wire diameter including insulation	0.7 mm ... 1.3 mm
Minimum external conductor diameter	3.5 mm
Maximum external conductor diameter	6 mm
Tightening torque, union nut	2 Nm
Wrench size, union nut	13 mm
Conductor cross section stranded min.	0.14 mm <sup>2</sup>
Conductor cross section stranded max.	0.34 mm <sup>2</sup>
Conductor cross section AWG/kcmil min.	26
Conductor cross section AWG/kcmil max	22

### Insulation material

Housing material	PBT
Material of the moulding mass	PUR
Contact material	Steel/copper
Contact surface material	Sn

### Pin assignment

Slot/position = Wire color or connection	1 / 4 (A) = WH
	1 / 2 (B) = GY/PK
	2 / 4 (A) = GN
	2 / 2 (B) = RD/BU
	3 / 4 (A) = YE

## Sensor/actuator box - SACB- 6/4-L- 5,0PUR QO-0,34 - 1548558

### Technical data

#### Pin assignment

	3 / 2 (B) = WH/GN
	4 / 4 (A) = GY
	4 / 2 (B) = BN/GN
	5 / 4 (A) = PK
	5 / 2 (B) = WH/YE
	6 / 4 (A) = RD
	6 / 2 (B) = YE/BN
	1-6 / 1 (+ 24 V) = BN
	1-6 / 3 (0 V) = BU

#### Cable

Cable type	PUR/PVC black
Cable abbreviation	LiYY11Y-HF
Conductor cross section	12x 0.34 mm <sup>2</sup> (signal line)
	2x 0.75 mm <sup>2</sup> (Power supply)
AWG signal line	22
AWG power supply	18
Conductor structure signal line	42x 0.10 mm
Conductor structure, voltage supply	96x 0.10 mm
Core diameter including insulation	1.5 mm (signal line)
	2 mm (Power supply)
Overall twist	Wires twisted in layers
External sheath, color	deep black RAL 9005
External cable diameter D	9.4 mm ±0.2 mm
Smallest bending radius, fixed installation	47 mm
Smallest bending radius, movable installation	94 mm
Number of bending cycles	1500000
Bending radius	94 mm
Traversing path	2 m
Traversing rate	2 m/s
Cable weight	141 kg/km
Outer sheath, material	PUR
Material, inner sheath	PVC
Material conductor insulation	PVC
Conductor material	Bare Cu litz wires
Nominal voltage, cable	≤ 500 V
Test voltage Core/Core	1500 V AC (signal line)
	2000 V AC (Power supply)
Ambient temperature (operation)	-30 °C ... 70 °C (cable, fixed installation)
	-5 °C ... 70 °C (cable, flexible installation)

# Sensor/actuator box - SACB- 6/4-L- 5,0PUR QO-0,34 - 1548558

## Classifications

### eCl@ss

eCl@ss 4.0	27250313
eCl@ss 4.1	27250313
eCl@ss 5.0	27143423
eCl@ss 5.1	27143423
eCl@ss 6.0	27143423
eCl@ss 7.0	27449001
eCl@ss 8.0	27279219

### ETIM

ETIM 3.0	EC001856
ETIM 4.0	EC002585
ETIM 5.0	EC002585

### UNSPSC

UNSPSC 6.01	31261501
UNSPSC 7.0901	31261501
UNSPSC 11	31261501
UNSPSC 12.01	31261501
UNSPSC 13.2	31261501

## Approvals

### Approvals

---

#### Approvals

UL Recognized / cUL Recognized / EAC / cULus Recognized

---

#### Ex Approvals

---

#### Approvals submitted

---

#### Approval details

UL Recognized 	
Nominal voltage UN	24 V

# Sensor/actuator box - SACB- 6/4-L- 5,0PUR QO-0,34 - 1548558

## Approvals

cUL Recognized	
Nominal voltage UN	24 V

EAC
-----

cULus Recognized
------------------

## Accessories

### Accessories

#### Device marking

Contact marker – zack marker strip - SS-ZB 17,5 WH - 0804963



Contact marker – zack marker strip, Strip, white, unlabeled, can be labeled with: Plotter, Mounting type: Snap into flat marker groove, Lettering field: 17.5 x 9 mm

Contact marker – zack marker strip - SS-ZB 17,5 YE - 0804976



Contact marker – zack marker strip, Strip, yellow, unlabeled, can be labeled with: Plotter, Mounting type: Snap into flat marker groove, Lettering field: 17.5 x 9 mm

#### Labeled device marker

Contact marker – zack marker strip - SS-ZB 17,5 WH CUS - 0824468



Contact marker – zack marker strip, can be ordered: Strip, white, labeled according to customer specifications, Mounting type: Snap into flat marker groove, Lettering field: 17.5 x 9 mm

## Sensor/actuator box - SACB- 6/4-L- 5,0PUR QO-0,34 - 1548558

### Accessories

Contact marker – zack marker strip - SS-ZB 17,5 YE CUS - 0824469



Contact marker – zack marker strip, can be ordered: Strip, yellow, labeled according to customer specifications, Mounting type: Snap into flat marker groove, Lettering field: 17.5 x 9 mm

---

### Mounting rail adapter

Assembly adapters - UTA 107 - 2853983

Universal DIN rail adapter



---

### Pressure nut

Connector - QO-SET - 1548626



QUICKON set for replacement purposes, consisting of splice ring, pressure nut and line seal

---

### Protective cap

Filler plugs - Q-PROT 9/11 - 1670235



Closing cap for Pg9/Pg11 to close unoccupied connections

---

### Screwdriver tools

Adapter insert - TSD-M SAC-BIT ADAPTER - 1212600



Adapter bit for TSD-M...torque tools, E6.3-1/4" drive with 4 mm hexagon to accommodate SAC bits

# Sensor/actuator box - SACB- 6/4-L- 5,0PUR QO-0,34 - 1548558

## Accessories

Tool - SAC BIT QUICKON-W13 - 1212033



Nut for assembling QUICKON pressure nuts with 13 mm wrench size, for 4 mm hexagonal drive

## Torque tool

Torque screwdriver - TSD 20 SAC - 1212020



Torque screwdriver, with preset torque of 2.0 Nm and 4 mm hexagonal drive for the pressure nut of the fast connection

Torque screwdriver - TSD-M 3NM - 1212225



Torque screw driver, accuracy as per EN ISO 6789 standard, adjustable from 1.2 - 3 Nm

## Drawings

Schematic diagram

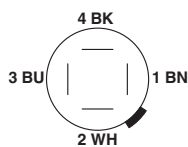

QUICKON connection, 4-pos.

Dimensioned drawing

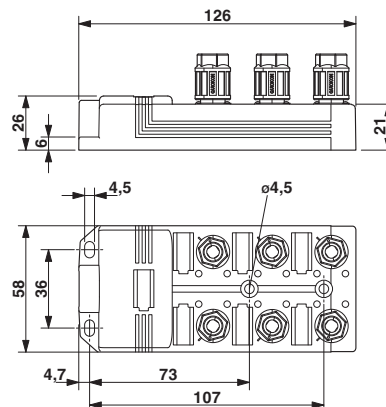

# Sensor/actuator box - SACB- 6/4-L- 5,0PUR QO-0,34 - 1548558

Circuit diagram

