

Sensor/actuator box header - SACB-4/ 4-L-C GG - 1698110

Please be informed that the data shown in this PDF Document is generated from our Online Catalog. Please find the complete data in the user's documentation. Our General Terms of Use for Downloads are valid (<http://phoenixcontact.com/download>)



Sensor/actuator box header, Connection method: M12 socket Plastic, Number of slots: 4, Number of positions: 4, Coding: A - standard, Slot assignment: single, Status indication: Yes, pnp; Master cable connection: Pluggable screw connection, Shielding: No

The illustration shows a version with 8 slots



Key Commercial Data

Packing unit	1 pc
Weight per Piece (excluding packing)	81.3 g
Custom tariff number	85444290
Country of origin	Poland

Technical data

General

Rated voltage	24 V DC
Max. operating voltage U_{max}	30 V DC
Current carrying capacity per I/O signal	2 A
Current carrying capacity per slot	4 A
Total rated current	10 A
	2x 8 A (For electrical isolation)
Number of positions	4
Number of slots	4
Flammability rating according to UL 94	V0
Sensor/actuator connection system	M12 socket

Ambient conditions

Degree of protection	IP65
	IP67
Ambient temperature (operation)	-25 °C ... 75 °C

Sensor/actuator box header - SACB-4/ 4-L-C GG - 1698110

Technical data

Local diagnostics function

Local diagnostics	Supply voltage per module Green LED
	Status display I/O Yellow LED

Master cable data/connection data

Connection method	Pluggable screw connection
Tightening torque slot sensor/actuator cable	0.4 Nm

Insulation material

Housing material	PA
Contact material	CuSn
Contact surface material	Ni/Au
Contact carrier material	PA
Material of contact, master cable side	CU alloy
Material of contact surface, master cable side	Sn
Material of the contact carrier on the master cable side	PA 66 V0
Material of threaded sleeve	PA
O-ring material	NBR

Pin assignment

Slot/position = Wire color or connection	1 / 4 (A) = 1 / 4
	2 / 4 (A) = 2 / 4
	3 / 4 (A) = 3 / 4
	4 / 4 (A) = 4 / 4
	1-4 / 1 (+ 24 V) = U _N
	1-4 / 3 (0 V) = 0 V
	1-4 / 5 (PE) = PE

Standards and Regulations

Connection in acc. with standard	CUL
Flammability rating according to UL 94	V0

Classifications

eCl@ss

eCl@ss 4.0	27140815
eCl@ss 4.1	27140815
eCl@ss 5.0	27143423
eCl@ss 5.1	27143423
eCl@ss 6.0	27143423

Sensor/actuator box header - SACB-4/ 4-L-C GG - 1698110

Classifications

eCl@ss

eCl@ss 7.0	27449001
------------	----------

ETIM

ETIM 2.0	EC000200
ETIM 3.0	EC001856
ETIM 4.0	EC002585
ETIM 5.0	EC002585

UNSPSC

UNSPSC 6.01	31261501
UNSPSC 7.0901	31261501
UNSPSC 11	31261501
UNSPSC 12.01	31261501
UNSPSC 13.2	31261501

Accessories

Accessories

Device marking

Zack marker strip - ZBN 18:UNBEDRUCKT - 2809128



Zack marker strip, Strip, white, unlabeled, can be labeled with: Plotter, Mounting type: Snap into tall marker groove, for terminal block width: 18 mm, Lettering field: 18 x 5 mm

Protective cap

Screw plug - PROT-M12 - 1680539



An M12 screw plug for the unoccupied M12 sockets of the sensor/actuator cable, boxes and flush-type connectors

Screwdriver tools

Sensor/actuator box header - SACB-4/ 4-L-C GG - 1698110

Accessories

Tool - SAC BIT M12-D15 - 1208432



Nut for assembling sensor/actuator cables with M12 connector and M12 connectors for assembly, with a knurl diameter of 15 mm, for 4 mm hexagonal drive

Tool - SACC BIT M12-D20 - 1208445



Nut for assembling M12 connectors for assembly with a knurl diameter of 20 mm, for 4 mm hexagonal drive

Philips screwdriver - SZK PZ2 VDE - 1206463



Screwdriver, PZ crosshead, VDE insulated, size: PZ 2 x 100 mm, 2-component grip, with non-slip grip

Torque tool

Torque screwdriver - TSD 04 SAC - 1208429



Torque screwdriver, with preset torque of 0.4 Nm and 4 mm hexagonal drive for M12 connectors

Required add-on products

Connector hood - SACB-C-H180-4/ 4- 5,0PUR - 1503014



Sensor/actuator connector hood, with master cable, marking label, for an SAC box with 4 single-occupied slots

Sensor/actuator box header - SACB-4/ 4-L-C GG - 1698110

Accessories

Connector hood - SACB-C-H180-4/ 4-10,0PUR - 1503027



Sensor/actuator connector hood, with master cable, marking label, for an SAC box with 4 single-occupied slots

Connector hood - SACB-C-H180 4- 4 PUR/ - 1698123



Connector hood, Application: Sensor/actuator box, Connection method: M12 socket Plastic, Number of slots: 4, Slot assignment: single, Status indication: No; Master cable connection: Pluggable screw connection 180°, PUR/PVC, Cable length: 0.5 m ... 50 m, Shielding: No

Connector hood - SACB-C-H180 8/16 - 1695977



Connector hood with integrated connector, for M12 sensor/actuator boxes with plastic thread and plug-in screw connection, for 4, 6 or 8 slots

Drawings

Schematic diagram

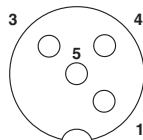

M12 slot, socket, 4-pos.

Schematic diagram

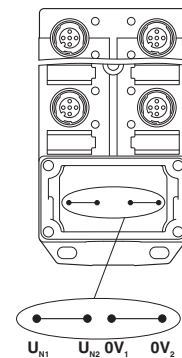

Potential U_{N1} and U_{N2} bridged. Potential assignment: $U_{N1} = U_{N2} =$ slots 1,2,3,4.

Sensor/actuator box header - SACB-4/ 4-L-C GG - 1698110

Schematic diagram

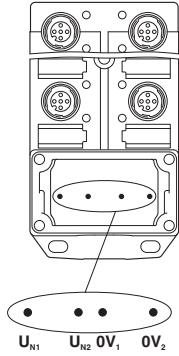

Circuit diagram

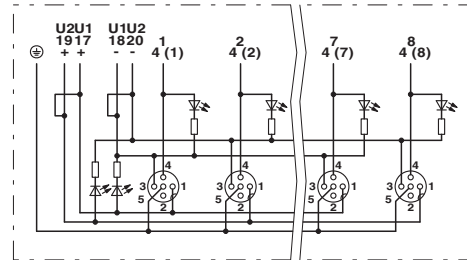

Electrically isolated. Potential assignment: U_{N1} = slots 1,3 and U_{N2} = slots 2,4.

Sensor/actuator box header - SACB-4/ 4-L-C GG - 1698110

Dimensional drawing

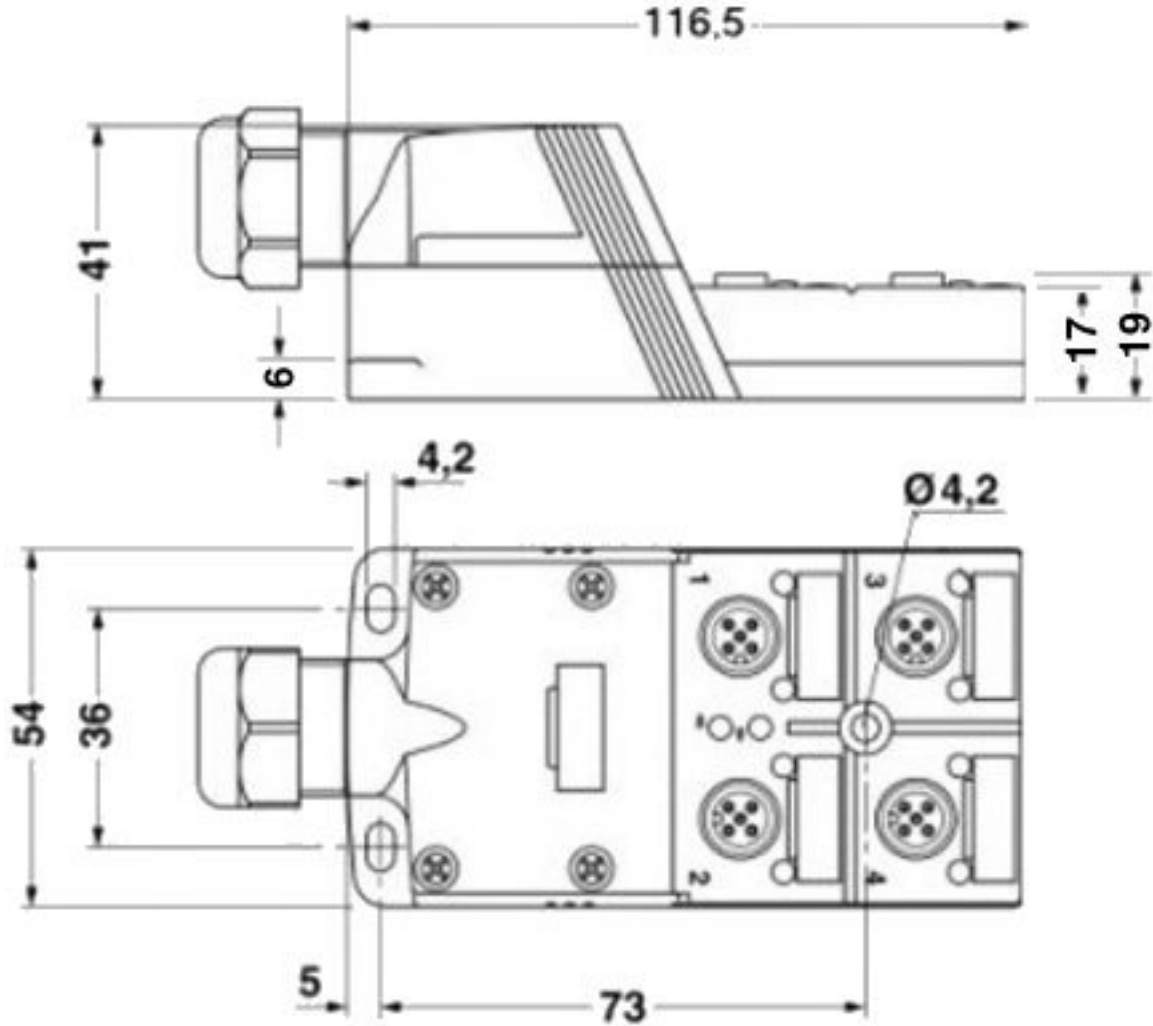

Mouser Electronics

Authorized Distributor

Click to View Pricing, Inventory, Delivery & Lifecycle Information:

[Phoenix Contact:](#)

[1698110](#)