

THIS DOCUMENT IS THE PROPERTY OF
KEYSTONE ELECTRONICS CORP. AND
SHALL NOT BE REPRODUCED, DISTRIBUTED
OR USED AS A BASIS FOR MANUFACTURE
WITHOUT PRIOR WRITTEN PERMISSION
FROM KEYSTONE ELECTRONICS CORP.

SPRING CONTACT TO
ACCEPT .080[2.03]
PIN DIA.

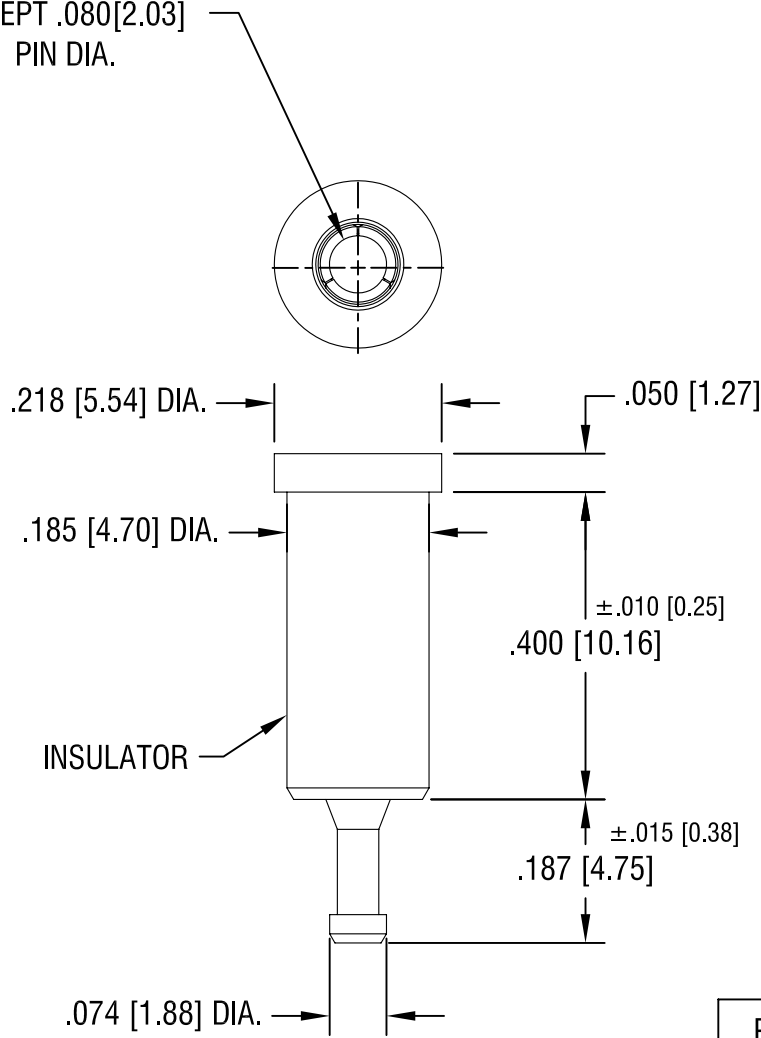

PART NO.	COLOR
11009	WHITE
11009-R	RED
11009-B	BLACK

NOTES:

1. TERMINAL JACK : MAT'L - BERYLLIUM COPPER (QQ-C-533)
2. BUSHING: MAT'L - PTFE

KEYSTONE ELECTRONICS CORP.

ASTORIA, N.Y. 11105-2017

PART NAME		PTFE INSULATED TEST JACK	
MATERIAL		AS NOTED	
FINISH		DRN BY	DATE
GOLD PLATE		N.T.	7.10.07
		APP'D	SCALE
		LN	4X
TOLERANCES	INCH [MM]	CODE	DWG NO.
DECIMAL	± .005 [± 0.15]	C/M	11009-
ANGULAR	± 1°		
UNLESS OTHERWISE SPECIFIED			

11.17.08	CHANGE AS PER ECN 08-177	A
DATE	DESCRIPTION	REV.

Mouser Electronics

Authorized Distributor

Click to View Pricing, Inventory, Delivery & Lifecycle Information:

[Keystone Electronics:](#)

[11009-B](#)