

**Housing Assy 5p Hybrid Std./Jr. Power Timer Tab & Rec.**

**DESIGN OBJECTIVES**

The product described in this document has not been fully tested to insure conformance to the requirements outlined below. Therefore, Tyco Electronics Brazil makes no representation or warranty, express or implied, that the product will comply with these requirements. Further, Tyco Electronics Brazil may change these requirements based on the results of additional testing and evaluation. Contact Tyco Engineering for further details.

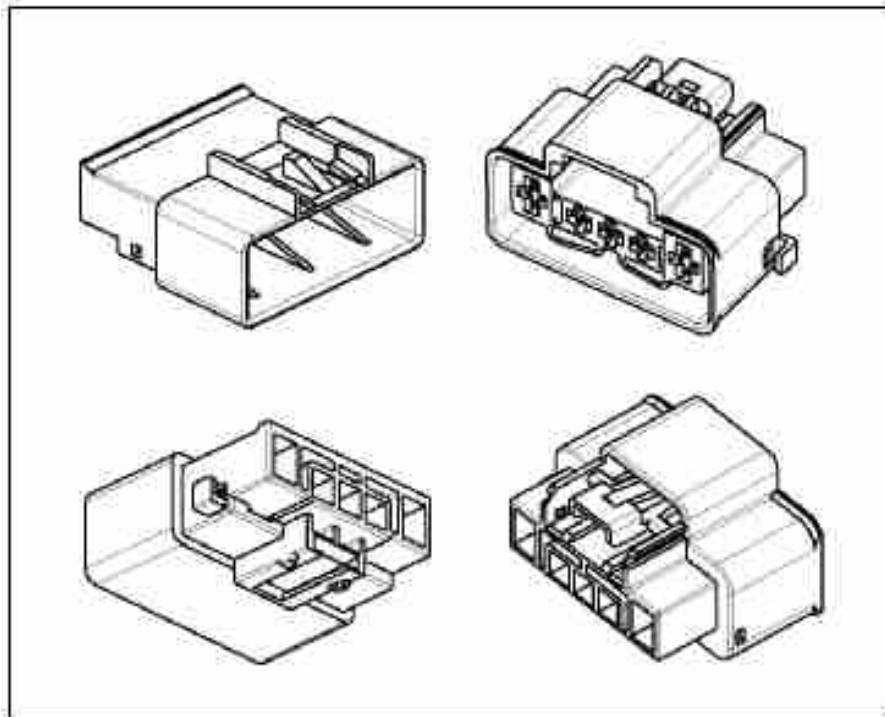

**HOUSING ASSY 5 POS. HYBRID STD/JR  
POWER TIMER TAB & REC.**

Prepared by : Cláudio Cassali

Approved by : Leandro W Prado

Tyco Electronics Brasil Ltda.

© 2002 Tyco Electronics Corporation , Harrisburg PA .  
Todos os direitos reservados .

\* Trademark  
| Indica alterações .

This specification is a restricted document.  
Tyco Electronics Brasil for the latest updated available

1 of 7

Loc. AP

## 1. SCOPE

### 1.1 Content

This specification covers the requirements for product performance, test method and quality assurance provisions of:

Tyco Part Number	"Trade Mark" Description	Wire Range (for contact only)
1599314-1	Housing Assy 5p Hybrid Jr./Std. Power Timer Tab	-----
1599317-1	Housing Assy 5p Hybrid Jr./Std. Power Timer Rec.	-----
964292	Tab Contact 2,8 x 0,8 mm Type "A"	0,2 - 0,5 mm <sup>2</sup>
964294		>0,5 - 1,0 mm <sup>2</sup>
964296		>1,0 - 2,5 mm <sup>2</sup>
969007	Tab Contact 5,8 x 0,8 mm Type "A"	0,2 - 0,5 mm <sup>2</sup>
964304		0,5 - 1,0 mm <sup>2</sup>
964306		>1,0 - 2,5 mm <sup>2</sup>
964308		> 2,5 - 4,0mm <sup>2</sup>
964280	Jr. Power Timer Rec. Contact	0,2 - 0,5 mm <sup>2</sup>
964284		>0,5 - 1,0 mm <sup>2</sup>
965999		>1,0 - 2,5 mm <sup>2</sup>
927839 / 927840	Standard Power Timer Rec. Contact	0,2 - 0,5 mm <sup>2</sup>
927827 / 927831		>0,5 - 1,0 mm <sup>2</sup>
927833 / 927837		>1,0 - 2,5 mm <sup>2</sup>
927824 / 927829		> 2,5 - 4,0mm <sup>2</sup>

### 1.2 Qualification

When tests are performed on the subject product line, the procedures specified in AMP 109 Series Specifications shall be used. All inspections shall be performed using the applicable inspection plan and product drawing.

## 2. APPLICABLE DOCUMENTS

The following documents form part of this specification to the extent specified herein. In the event of conflict between the requirements of this specification and the product drawing, the product drawing shall take precedence. In the event of conflict between the requirements of this specification and the referenced documents, this specification shall take precedence.

### 2.1 Tyco Documents

- 109-1 General Requirements for Test Specifications;
- 108-18063 Product specification for Tab 2,8 x 0,8 mm;
- 108-18013 Product specification for Junior Power Timer Rec;
- 108-18064 Product specification for Tab 5,8 x 0,8 mm;
- 108-18025 Product specification for Standard Power Timer Rec;
- 114-18051 Application specification for Tab 2,8 x 0,8 mm;
- 114-18050 Application specification for Junior Power Timer Rec;
- 114-18052 Application specification for Tab 5,8 x 0,8 mm;
- 114-18037 Application specification for Standard Power Timer Rec.

## 2.2 Other Documents

- 91107/13 (T2) Cable Specification. - FIAT;
- 9.91320/02 Connector Specification. Rev. Mar, 18<sup>th</sup> 2004 - FIAT;
- 7.Z8260 Test Spec, general requirements for test methods. Rev. Mar, 18<sup>th</sup> 2004.

## 3. QUALITY ASSURANCE PROVISIONS

### 3.1 Sample Preparation

The test samples to be used for the tests shall be prepared by randomly selecting them from the current production, and the contacts shall be crimped in accordance with the relevant Application Specification. No sample shall be reused, unless otherwise specified.

### 3.2 Test conditions

All the tests shall be performed under the combination of the following test conditions, unless otherwise specified.

Room Temperature:  $23 \pm 5^{\circ}\text{C}$   
Relative Humidity: 45-75%  
Atmospheric Pressure: 860 –1060 mbar

## 4. REQUIREMENTS

### 4.1 Design and Construction

Products shall be of the design, construction and physical dimensions specified on the applicable drawings.

### 4.2 Materials

- a) Housings : P.A. 6.6 + 15% G.F.
- b) Secondary Locks : P.A. 6.6 + 15% G.F.

### 4.3 Ratings

- a) Working Temperature :  $-25^{\circ}\text{C}$  to  $105^{\circ}\text{C}$  ;
- b) Operating Voltage : 24Vdc;
- c) Continuous Current : Junior Power Timer – 30A Máx;  
1. Standard Power Timer – 40A Máx;
- d) Vibration Level : See item 4.5.6.3.

### 4.4 Performance and Test Description

The product is designed to meet the electrical, mechanical and environmental performance requirements specified in Table 1. All tests are performed at ambient environmental conditions per AMP Specification 109-1 unless otherwise specified.

## 4.5 Test Requirements and Procedures Summary

Item	Test Items	Requirements	Procedures
<b>4.5.1 Appearances</b>			
4.5.1.1	Confirmation of Product and visual examination	Product shall be conforming to the requirements of applicable product drawing and Application Specification.	Visually, dimensionally and functionally inspected per applicable quality inspection plan.
<b>4.5.2 Electrical Requirements</b>			
4.5.2.1	Voltage Drop	= 4mV/A as new and after ten insertions / extractions for Junior Power Timer. = 2mV/A as new and after ten insertions/extractions for Standard Power Timer	Measure initial milivolt drop of contact test circuit in mated connectors: at 10 mm max from the connector edges
4.5.2.2	Insulation resistance	= 10 MO	Between two adjacent contacts apply 500 Vdc per one minute
4.5.2.3	Dielectric breakdown resistance	> 1000 V eff.	Between two adjacent contacts apply voltage per one minute
<b>4.5.3 Terminal Mechanical Requirements</b>			
4.5.3.1	Contact insertion force into housing	= 15N for cable cross section = 1 mm <sup>2</sup> and = 30N for cable cross section >1 mm <sup>2</sup> .	Apply an axial force. Operation speed: 25-50mm/min
4.5.3.2	Contact extraction force from housing with Sec. Lock actuated.	= 100N for terminal Junior Power Timer and = 140N for terminal Standard Power Timer.	Apply an axial force. Operation speed: 25-50mm/min
<b>4.5.4 Connector Mechanical Requirements</b>			
4.5.4.1	Connector mating and unmating force	= 75N for first insertion / extraction force.	Apply an axial force. Operation speed: 25mm/min
4.5.4.2	Connector unmating force with lock actuated.	Unmating force when connection is fully mated - = 100N	Mate the connector on its counterpart. Pull the connector with an operating speed 60 ±10mm/min
4.5.4.3	Polarization effectiveness check	No electrical contact admitted.	After positioning the connector in a not right way on the relevant counterpart, apply along the longitudinal axis a 100N force.

Table 1

Item	Test Items	Requirements	Procedures
<b>4.5.5 Mechanical Requirements for Secondary Lock</b>			
4.5.5.1	Captivity test on secondary lock in open and pre-coupling position.	= 20N	Apply to the Secondary lock, an axial force of 20N in opening direction. Operation speed: 50 mm/min.
4.5.5.2	Closing force of secondary lock with all contacts fully inserted into their cavities.	= 40N	Apply to the Secondary lock an increasing load parallel to its closing direction. Operation speed: 50 mm/min.
4.5.5.3	Closing force of secondary lock with one terminal not inserted into the cavity.	= 120N	Apply to the Secondary lock an increasing load parallel to its closing direction. Operation speed: 50 mm/min.
<b>4.5.6 Connector Environmental Requirements</b>			
4.5.6.1	Resistance to low temperature	No deformation or cracking of the plastic parts after one mating/unmating operation of connector onto its relevant counterpart	After cooling the product at: -40°C for 2 hours. subsequent Stabilization at ambient 0°C.
4.5.6.2	Accelerated aging resistance	No deformation or cracking of the plastic parts. Voltage drop as point 3.5.2.1, plus 50% max increasing admitted. Insulation resistance and dielectric breakdown as point 3.5.2.2 and 3.5.2.3. Initial Contact resistance value plus 50% max increasing admitted. After 10 mating/unmating: mechanical requirements as at new plus 50% max Increasing admitted.	- 5 cycles composed of: 2 hrs at +125 ± 2°C, 2 hrs at -25 ± 2°C. - 5 cycles composed of: 2 hrs at +125 ± 2°C, 2 hrs at +40 ± 2°C and 90-95% R.H., 2 hrs at - 25°C ± 2°C. - 200 hrs at +125 ± 2°C (Mated connector)
4.5.6.3	Random Vibration	Visual examination. No electrical discontinuity greater than 1000 per t > 1µs. An increase of 50% of voltage drop of initial value is admitted. A decrease of 50% of mechanical requirements initial value is admitted.	Connector fully loaded with max. section wires 400 mm long. Connector mated with relevant counterpart. Positioning the connector onto vibration plate take care that cables can float freely. Load each way of connector assembly with 100 mA max. Apply random vibration to connector as per diagram of figure 1, for 180 hours in the following sequence: 4h at + 85°C; 4h at 40°C 90-95% U.R.; 4h at -25°C.

Table 1 – Cont.

## 5. TEST SEQUENCE

Item	Test Items	Test Group						
		A	B	C	D	E	F	G
4.5.1.1	Confirmation of Product	1, 4	1, 6	1, 3	1, 9	1, 4	1, 4	1, 6
4.5.2.1	Voltage Drop				2, 6			2, 5
4.5.2.2	Insulation resistance				3, 7			
4.5.2.3	Dielectric breakdown resistance				4, 8			
4.5.3.1	Contact insertion force into housing	2						
4.5.3.2	Contact extraction force from housing without Sec. Lock actuated	3						
4.5.4.1	Connector mating and unmating force					3	3	3
4.5.4.2	Connector unmating force with lock actuated.		2					
4.5.4.3	Polarization effectiveness check		3					
4.5.5.1	Captivity test on secondary lock in open and pre-coupling position.			2				
4.5.5.2	Closing force of secondary lock with all contacts fully inserted into their cavities.		4					
4.5.5.3	Closing force of secondary lock with one terminal not inserted into the cavity.		5					
4.5.6.1	Resistance to low temperature					2		
4.5.6.2	Accelerated aging resistance				5			
4.5.6.3	Random Vibration							4

Table 2

## ANNEX 1

FIGURE 1

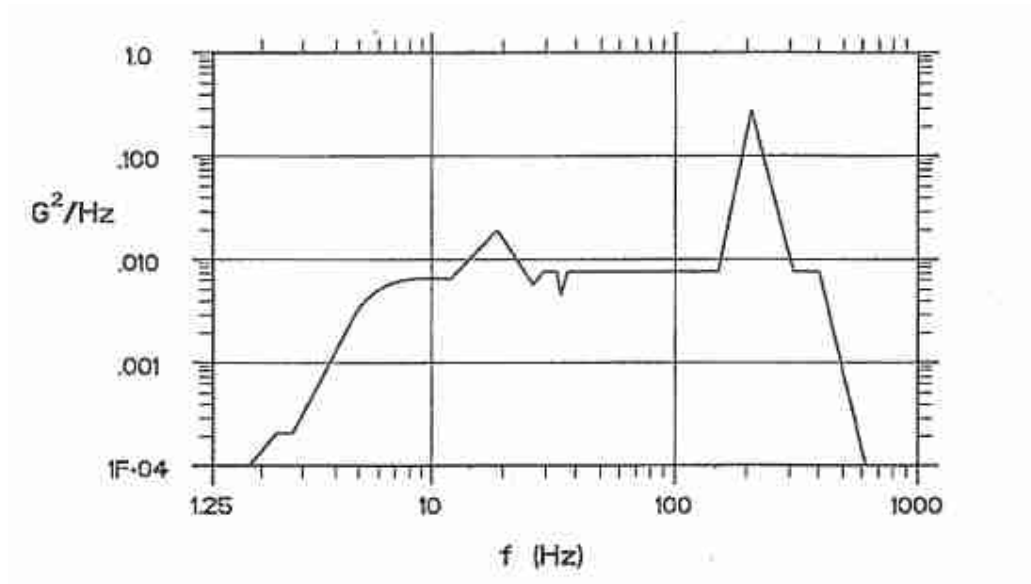
Random vibration  
PSD curve.

f (Hz)	8	12	18	30	50	72	150	200	300	400
G <sup>2</sup> / Hz	0,006	0,006	0,018	0,006	0,006	0,006	0,009	0,280	0,007	0,006