

PRODUCT NO	PACKAGING
10117780-001LF	TAPE AND REEL

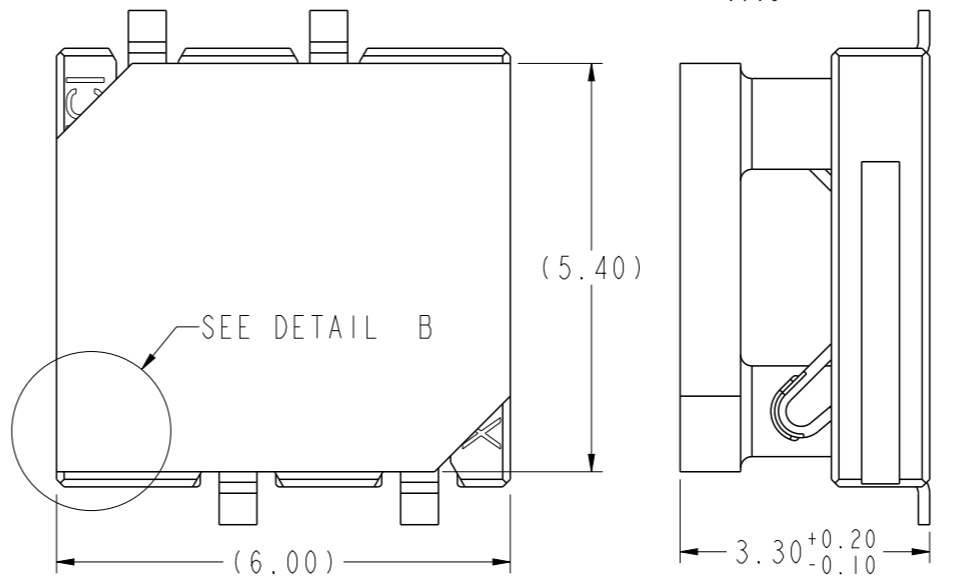
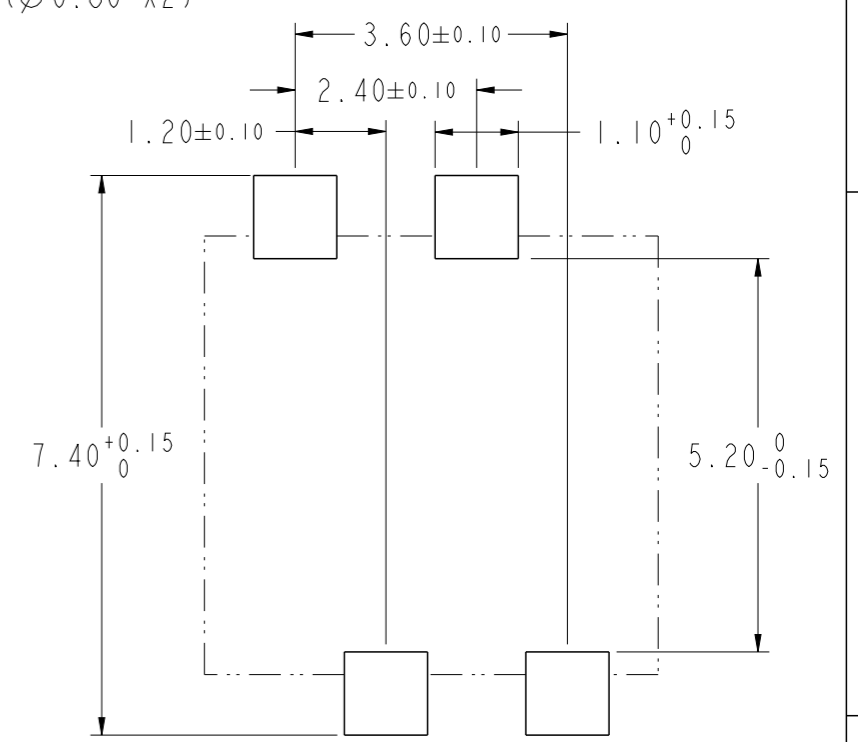
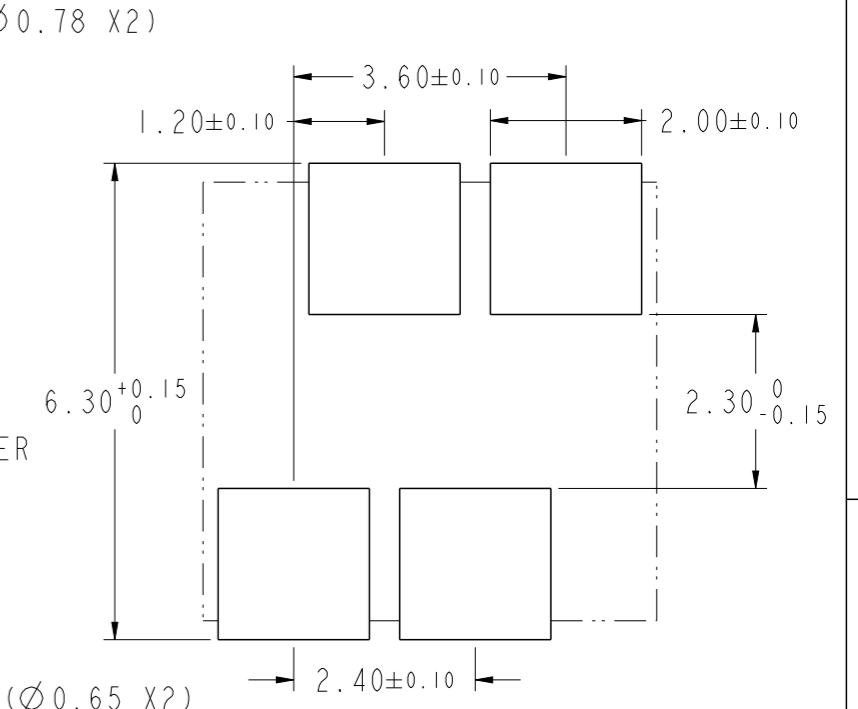
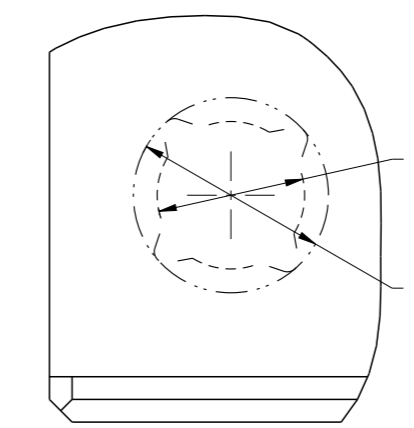
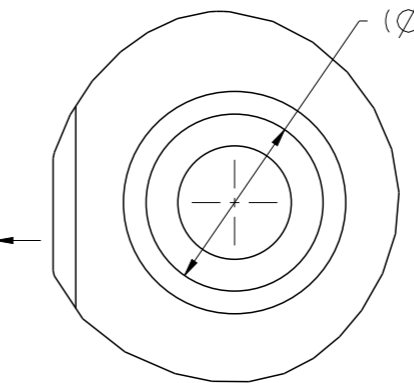
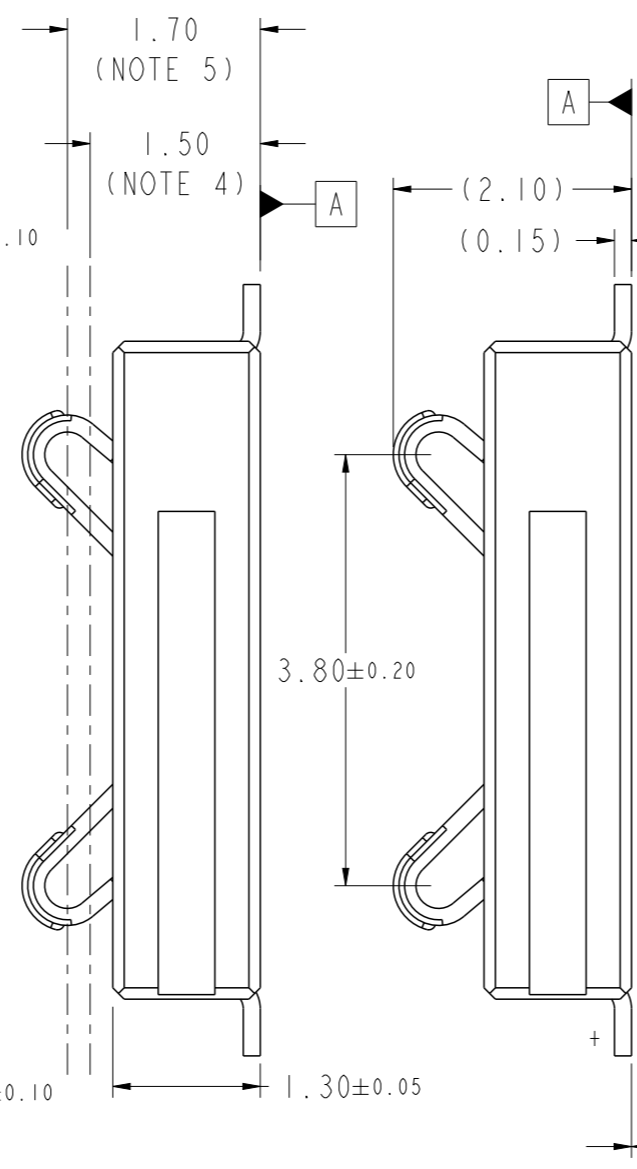
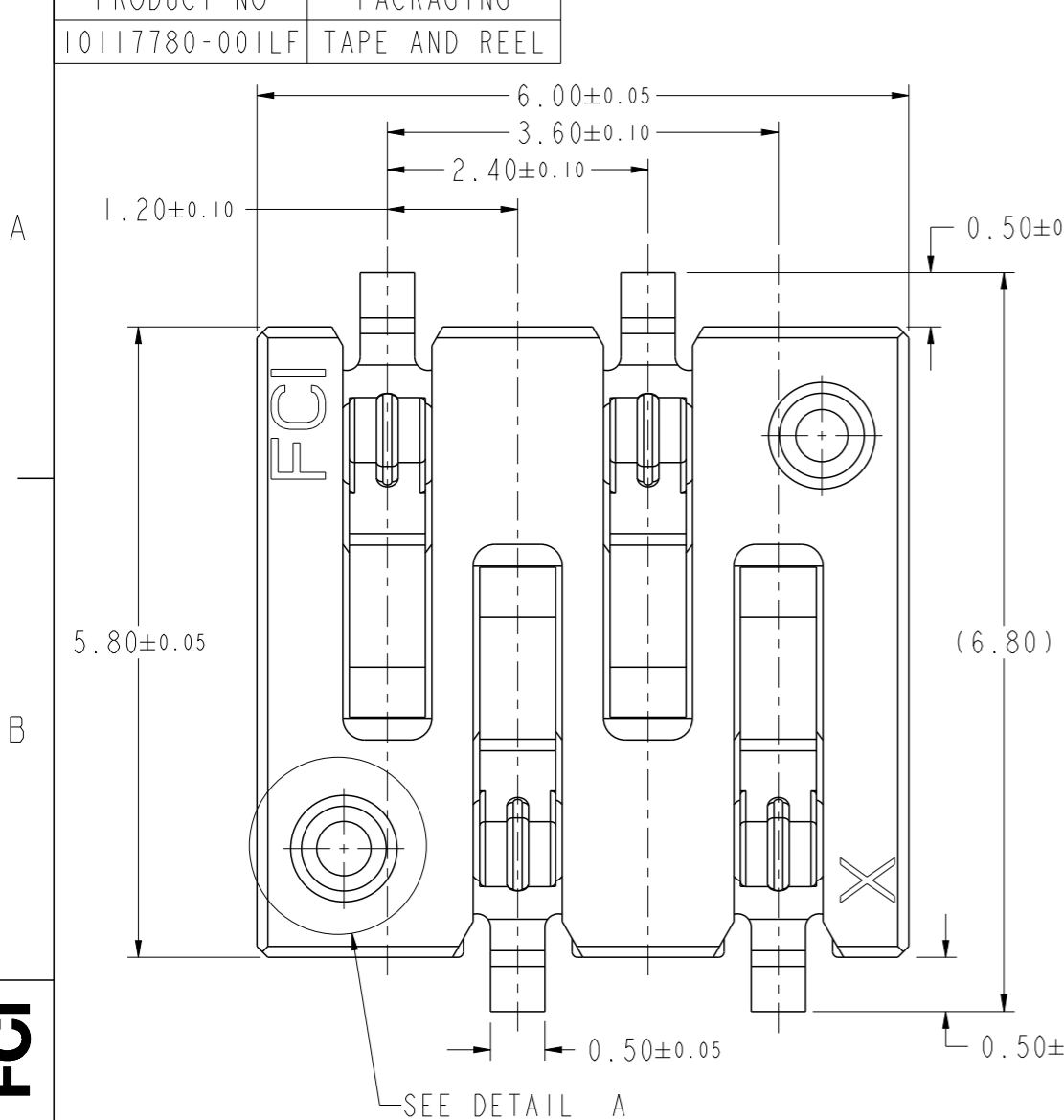

- NOTES:
- HOUSING: HIGH TEMPERATURE THERMOPLASTIC UL 94V-0, COLOUR: BLACK
 - CONTACTS: COPPER ALLOY.
PLATING SPEC: 0.2um MIN Au AT CONTACT AREA,
0.076um MIN Au AT SOLDER TAIL,
OVER 1.27um MIN Ni UNDERPLATE OVERALL
 - COVER: HIGH TEMPERATURE THERMOPLASTIC UL 94V-0, COLOUR: BLACK
 - AT 1.5mm HEIGHT, CONTACT GAP MEASUREMENT SHALL BE 4.2.
 - AT 1.7mm HEIGHT, CONTACT NORMAL FORCE SHALL BE ABOVE 40gf.
 - SOLDER TAIL CONPLANARITY SHALL BE 0.1mm MAX.
 - COVER HOLDING FORCE, SHALL BE WITHIN 20gf AND 600gf.
 - THIS PRODUCT MEETS EUROPEAN UNION DIRECTIVES AND OTHER COUNTRY REGULATIONS AS DESCRIBED IN GS-47-0004.
 - THE HOUSING WILL WITHSTAND EXPOSURE TO 260°C PEAK TEMPERATURE FOR 10 SECONDS IN A CONVECTION, INFRA-RED OR VAPOUR PHASE REFLOW OVEN.

spec ref	-	dr	Dennis Goh	2011/06/29	projection	MM	size	A3	scale	15:1
tolerance std	ASME Y14.5	eng	Dennis Goh	2017/04/25			ecn no	ELX-S-26774-1	rel level	Released
TOLERANCES UNLESS OTHERWISE SPECIFIED		chr	-	app						
surface	linear	0.X	±0.25	Amphenol FCI		4 PINS SPINDLE CONNECTOR		dwg no 10117780	rev B	
		0.XX	±0.13							
		0.XXX	±0.05							
ASME Y14.5	angular	0°	±°	cat. no.	Product - Customer Drw			sheet 1 of 1		

© 2016 AFCI
 Amphenol FCI