

DATE	DESCRIPTION	REV.
2.17.10	CHANGE AS PER ECN 10-014	A
10.08.13	CHANGE AS PER ECN 13-090	B

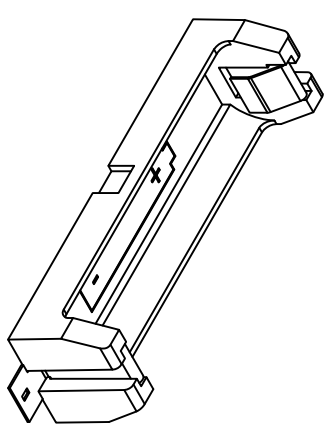
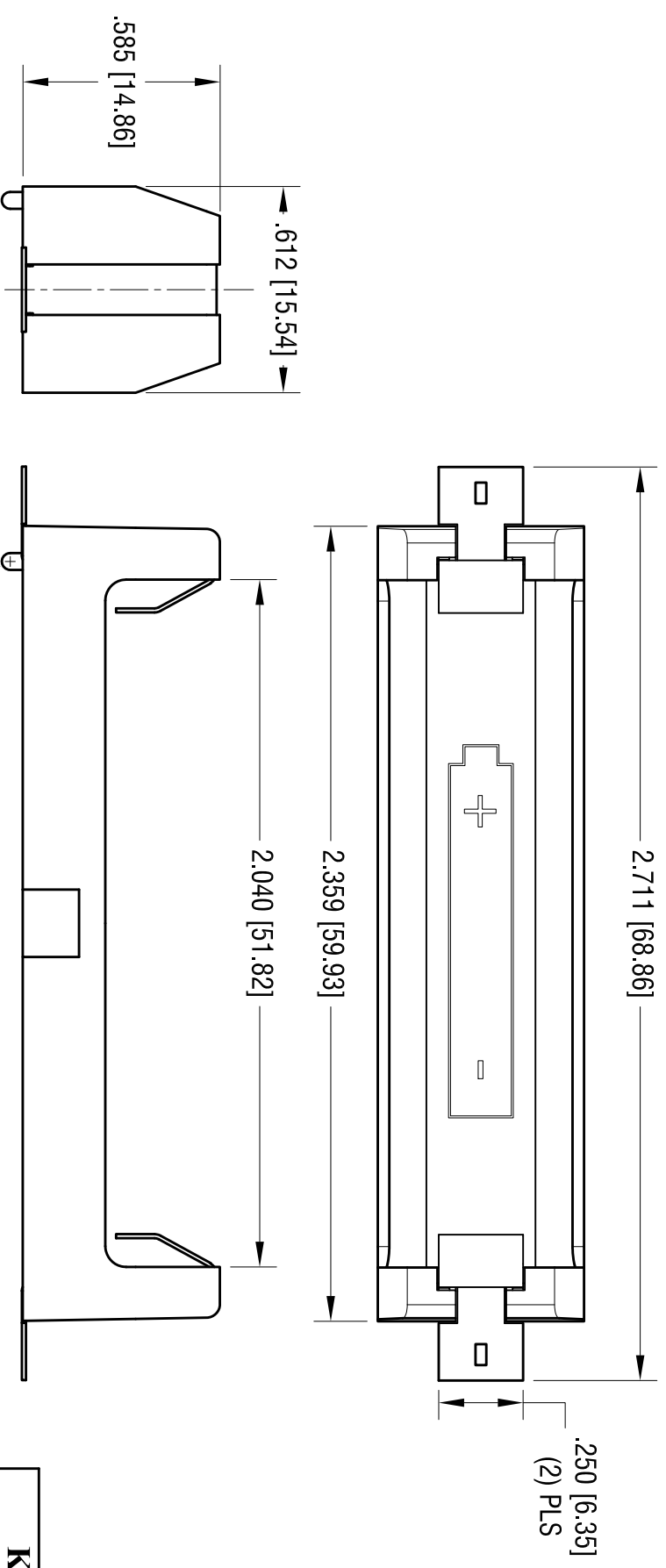
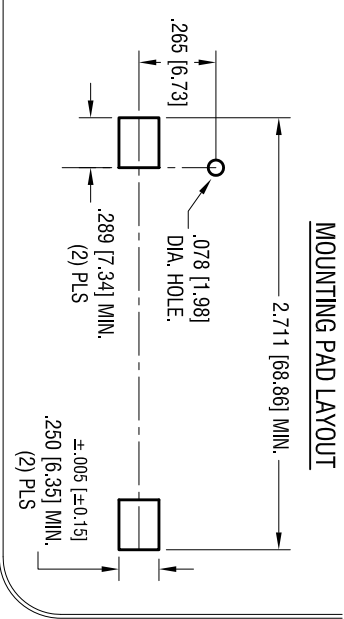

- NOTE:
1. BASE:
MATEL: HEAT RESISTANCE NYLON
STANVYL 46 OR EQUIVALENT
 2. CONTACT:
MATEL: .012 [0.30] THK STAINLESS STEEL
FINISH: GOLD FLASH, OVER NICKEL PLATE.

THIS DOCUMENT IS THE PROPERTY OF KEYSTONE ELECTRONICS CORP. AND SHALL NOT BE REPRODUCED, DISTRIBUTED OR USED AS A BASIS FOR MANUFACTURE WITHOUT PRIOR WRITTEN PERMISSION FROM KEYSTONE ELECTRONICS CORP.

KEYSTONE ELECTRONICS CORP.			
www.keystelco.com • ASTORIA, N.Y. 11105-2017 • Tel (718) 956-8900			
PART NAME		SM BATTERY HOLDER, AA	
MATERIAL		AS NOTED	
FINISH	AS NOTED	DRN BY	NT
TOLERANCES		CODE	DWG NO.
INCH	± .010 [± 0.25]	C	1024
DECIMAL	± 1 st		
ANGULAR			
UNLESS OTHERWISE SPECIFIED			
DATE	12.09.09	SCALE	2X