

DATE

DESCRIPTION

REV.

MOUNTING PAD LAYOUT



2.140 MAX.

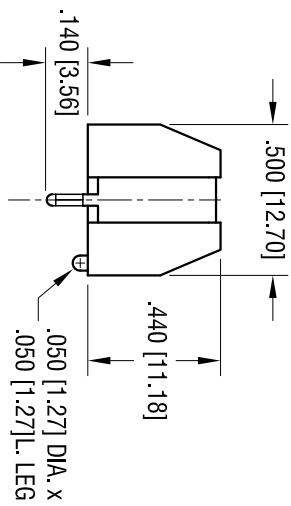
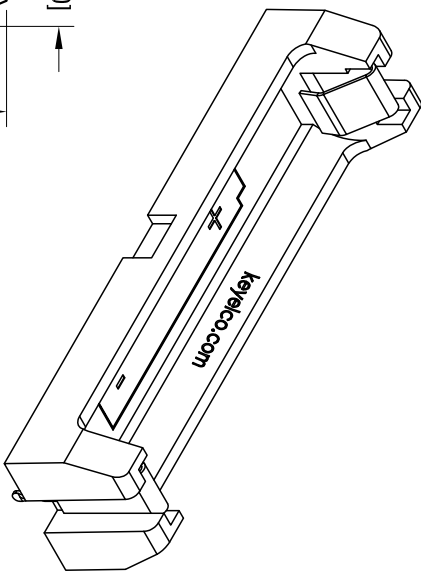
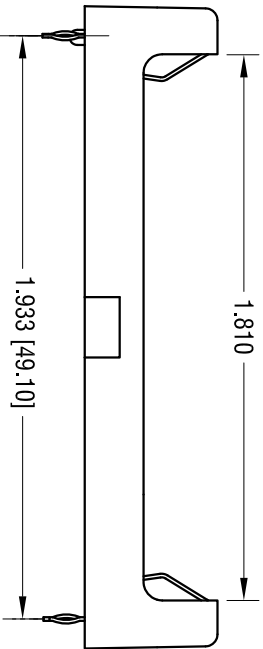
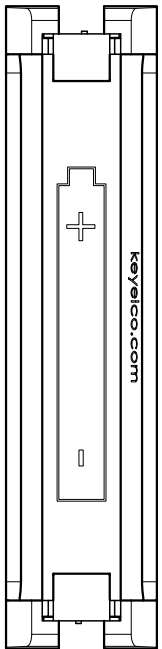

- NOTE:
- BASE: HEAT RESISTANCE NYLON
STANLYL 46 OR EQUIVALENT
 - CONTACT: MATL: .012 [0.30] THK PHOSPHOR BRONZE
FINISH: TIN NICKEL PLATE.

THIS DOCUMENT IS THE PROPERTY OF KEYSTONE ELECTRONICS CORP. AND SHALL NOT BE REPRODUCED, DISTRIBUTED OR COPIED IN ANY MANNER WITHOUT PRIOR WRITTEN PERMISSION FROM KEYSTONE ELECTRONICS CORP.

KEYSTONE ELECTRONICS CORP.			
www.keystone.com • ASTORIA, N.Y. 11105-2017 • Tel (718) 956-8900			
PART NAME THM BATTERY HOLDER, AAA			
MATERIAL AS NOTED			
FINISH AS NOTED		DRN BY NT	
AS NOTED		DATE 8.31.09	
TOLERANCES DECIMAL ± .010 [± 0.25]		CODE C	
ANGULAR ± 1°		DWG NO. 1021	
UNLESS OTHERWISE SPECIFIED		SCALE 2X	