

PRODUCT NUMBER	PLATING OPT.
10120667-XXX	OPTION 1
10120667-XXXLF	OPTION 2

PART NUMBER DESCRIPTION

10120667 - X 01LF

BASE NUMBER

HOUSING COLOR:
1: BLACK
3: NATURAL

1 X 2 VERTICAL RECEPTACLE CONNECTOR

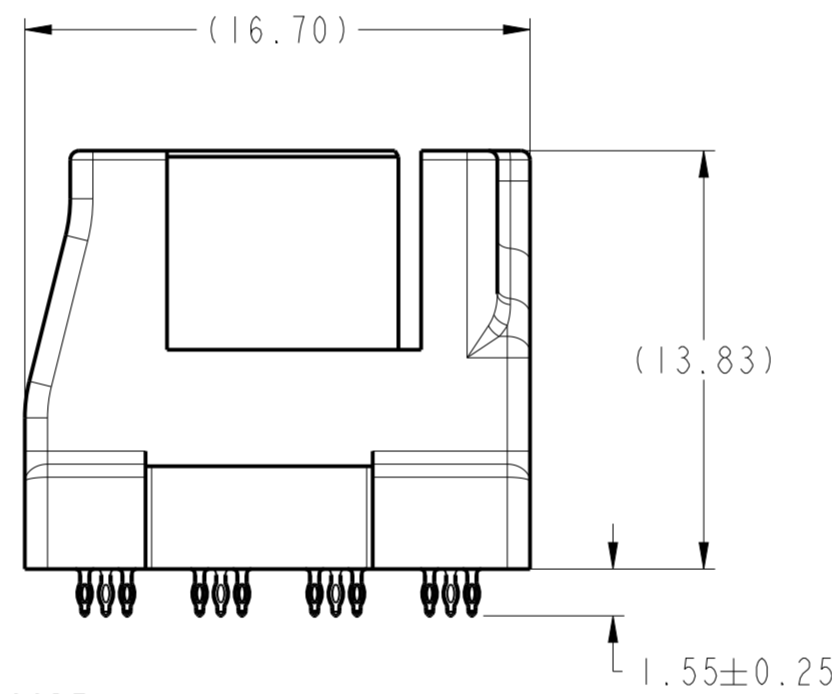
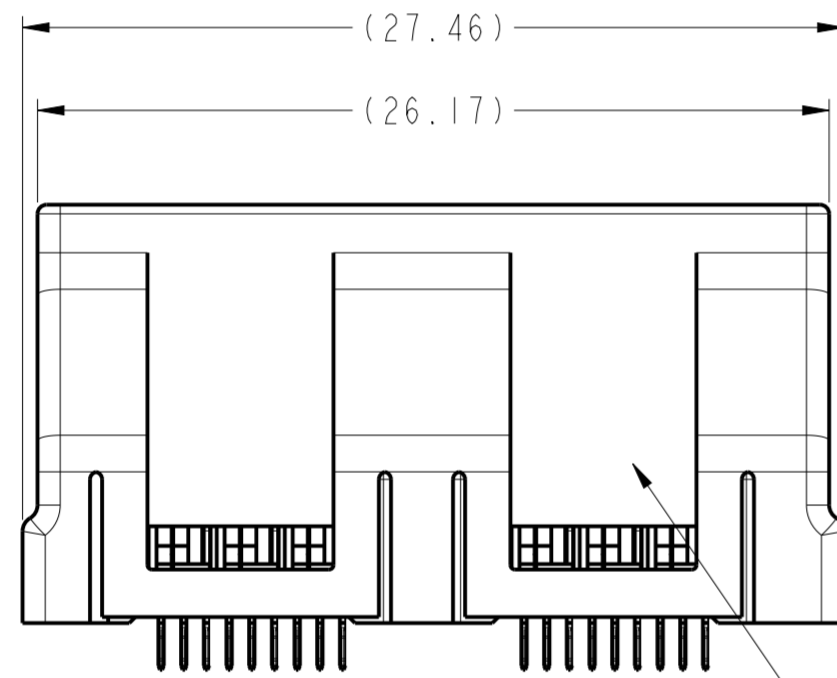
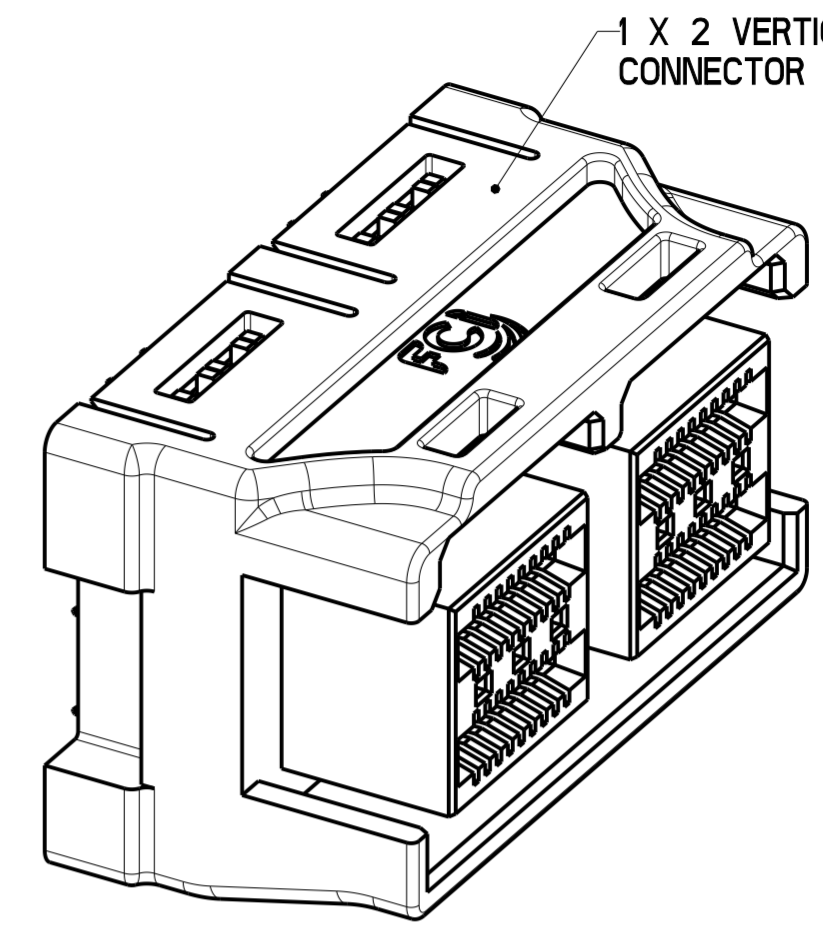
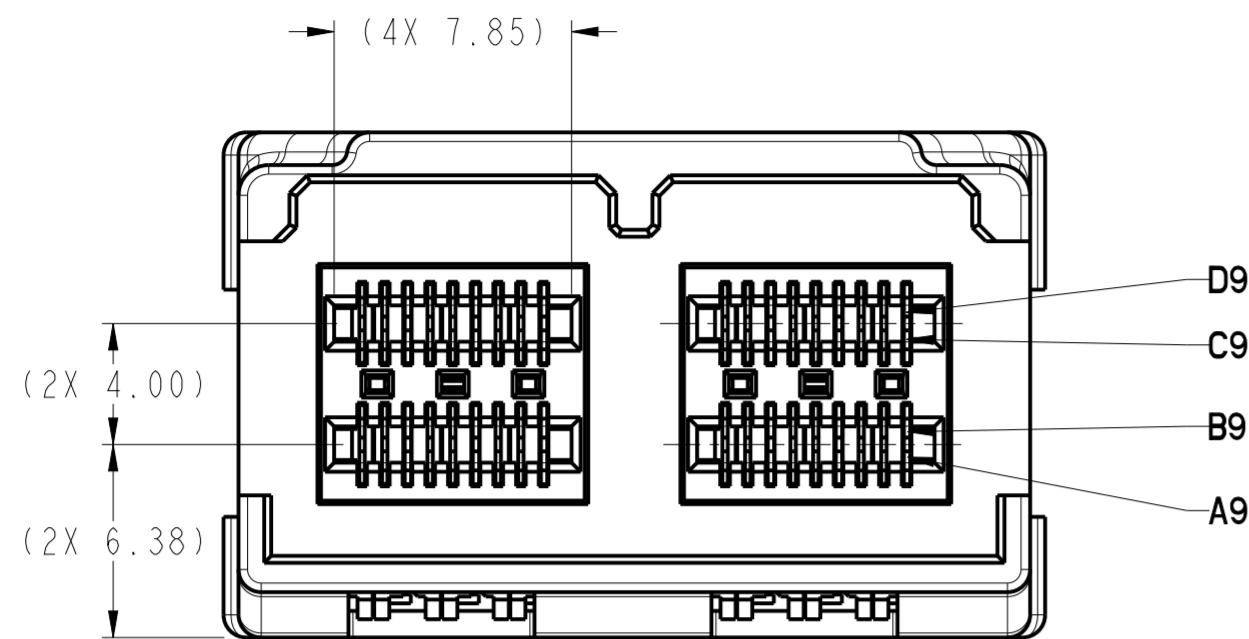

(0.75) TYP

FCI P/N AND DATE CODE ON THIS SURFACE $\triangle F$

5X ϕ 1.70 HOLE

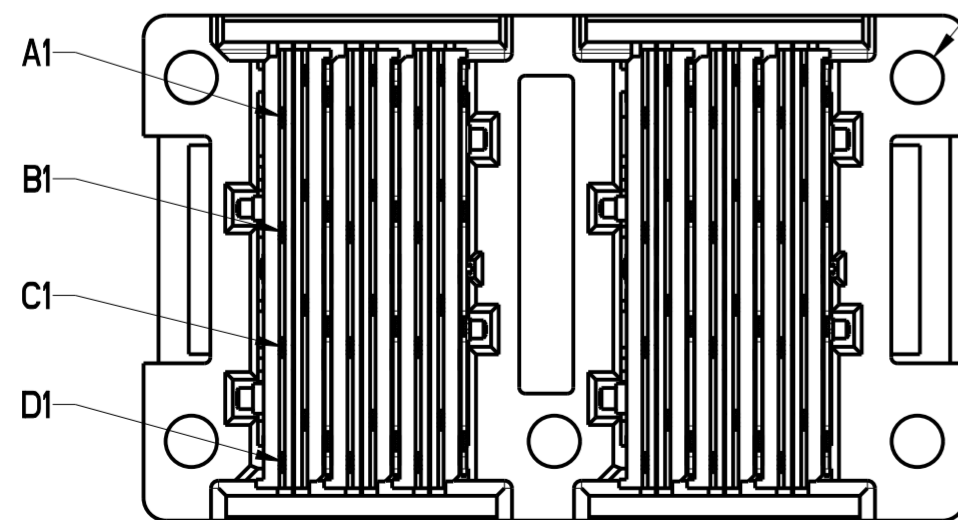

NOTES:

- CONNECTOR HOUSING: HIGH TEMPERATURE THERMOPLASTIC GLASS FILLED, UL 94V-0
TERMINALS: COPPER ALLOY
- FINISHES:
CONTACT AREA: 0.76um GOLD OVER 2.54 um MIN NICKEL WITH PAO LUBE.
TAIL AREA:
OPTION 1: 0.76um - 1.52um TIN/LEAD (90/10) OVER 2.54um MIN NICKEL.
OPTION 2: 0.76um - 1.52um TIN (LEAD FREE) OVER 2.54um MIN NICKEL.
- PRODUCT SPECIFICATION: GS-12-650
APPLICATION SPECIFICATION: GS-20-0356
PACKING SPECIFICATION: GS-14-1490
- MOUNTING HARDWARE:
 $\triangle F$ OPTION 1: M2 X 0.91 SELF-THREADING SCREW
OPTION 2: M2 X 0.80 SELF-THREADING SCREW
MOUNTING SCREW LENGTH: PCB THICKNESS + (2.5±0.35)mm. $\triangle F$
- THIS CONNECTOR IS DESIGNED TO MEET THE REQUIREMENT OF INDUSTRY SPECIFICATION SFF-8643.

spec ref	-	dr	Deborah Ingram	2012/04/10	projection	MM	size	A2	scale	4:1
tolerance std	ASME Y14.5	eng	Jacklin Zou	2015/12/09			ecn no	ELX-DG-22744-1		
TOLERANCES UNLESS OTHERWISE SPECIFIED		chr	Zhen Luo	2015/12/22				rel level	Released	
surface	✓	appr	Pei-Ming Zheng	2015/12/23	product family	INTERNAL VERTICAL ASSEMBLY		dwg no	10120667	
ASME Y14.5	linear	www.fci.com		cat. no.	Product - Customer Draw		rev	F		
	0.X									
	0.XX									
	0.XXX									
	angular									

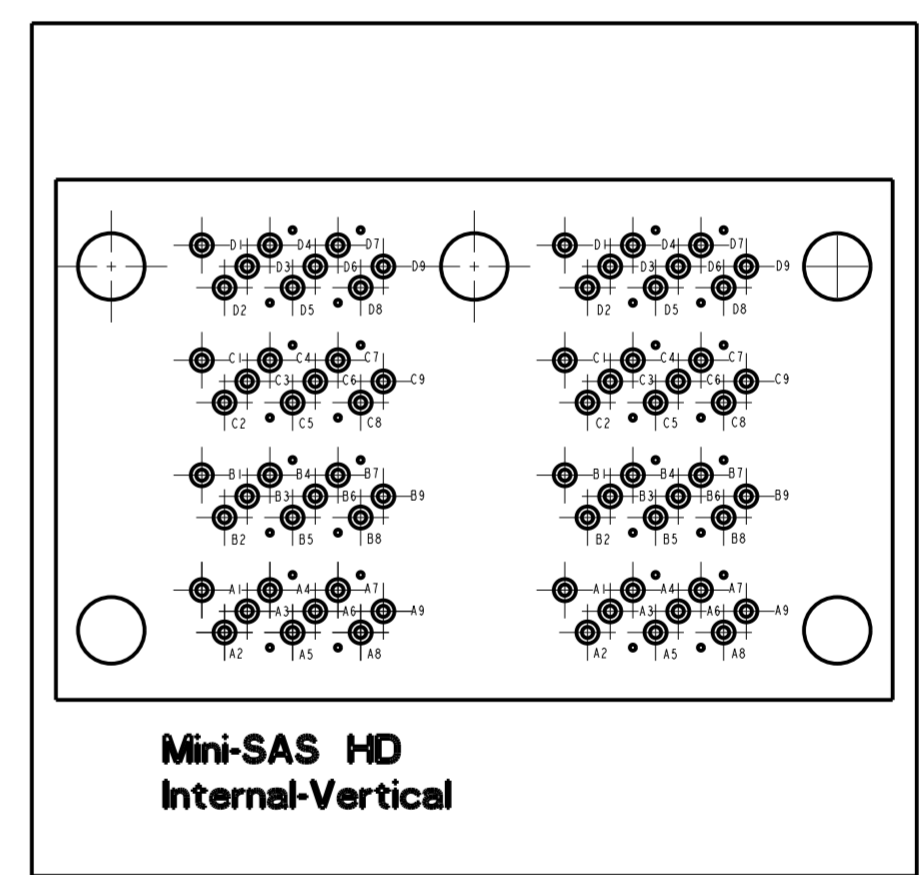
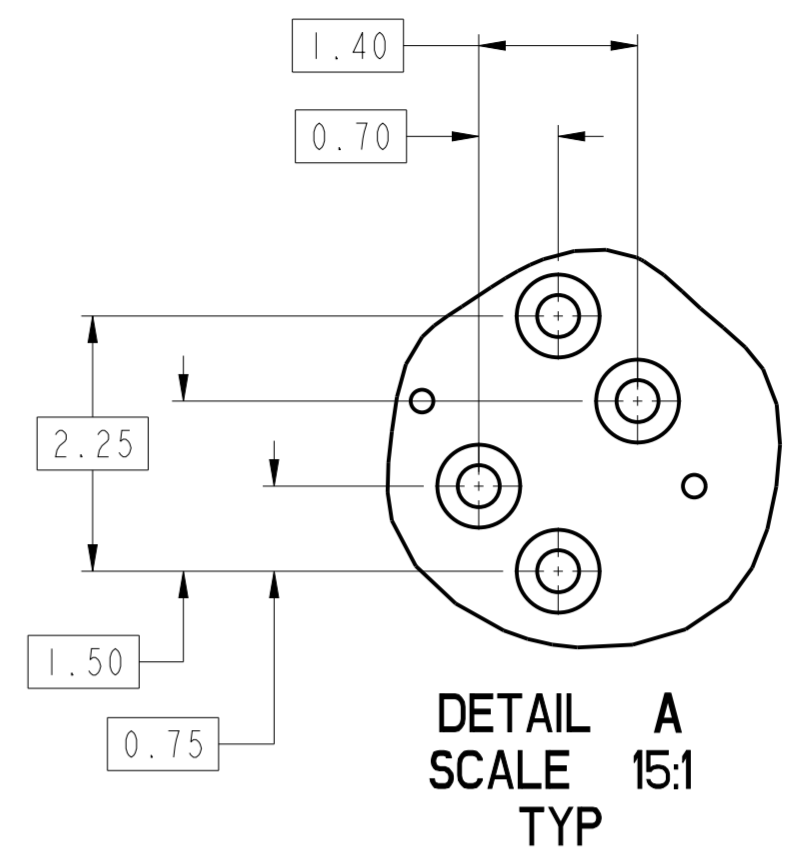
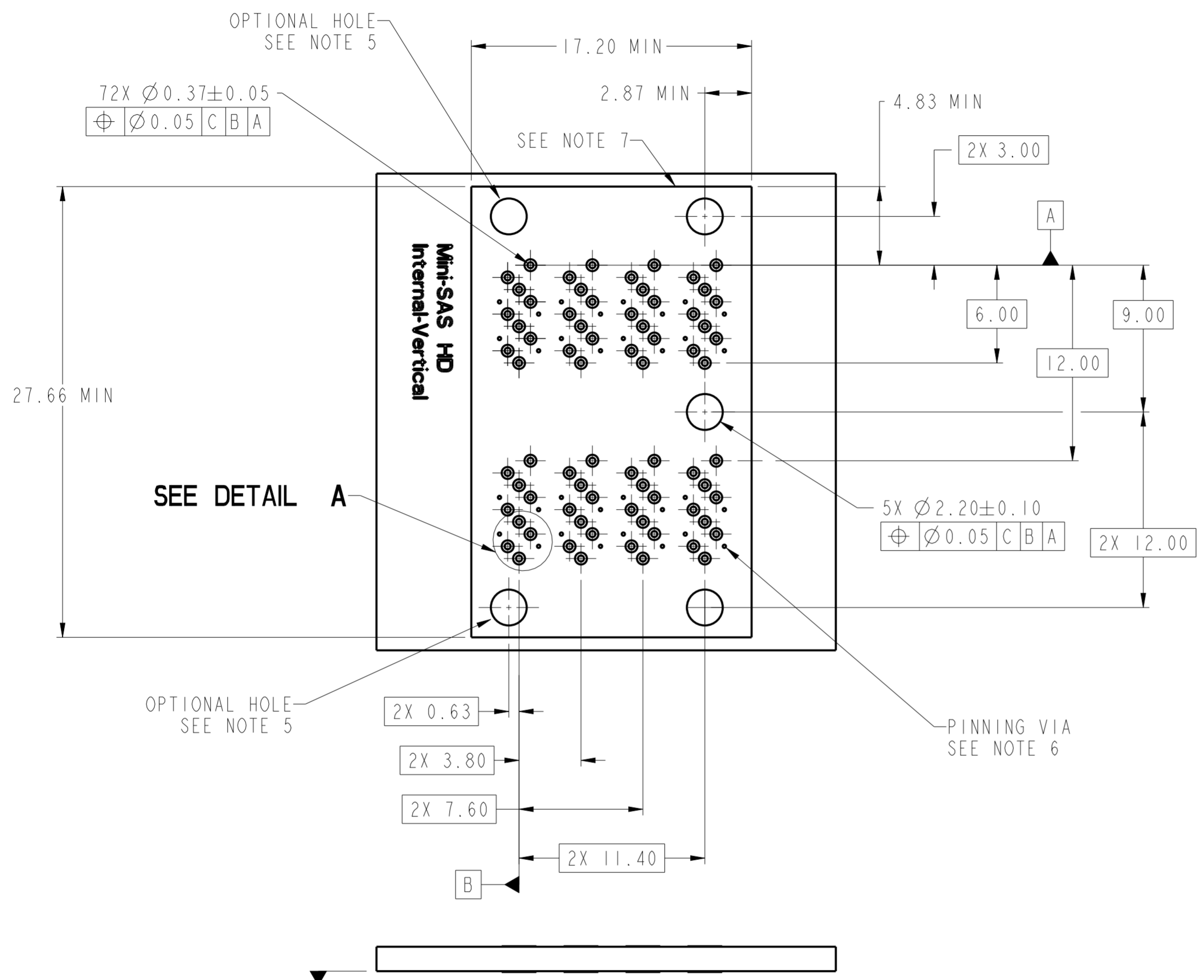

**RECOMMENDED BOARD LAYOUT
SCALE 8:1**

- NOTES:
1. RECOMMENDED DRILL SIZE FOR A $\varnothing 0.37$ FINISHED PTH IS $\varnothing 0.457$ (#77 DRILL).
 2. RECOMMENDED ANNULAR RING AROUND $\varnothing 0.37$ FINISHED PTH IS $\varnothing 0.73$.
 3. MINIMUM RECOMMENDED SPACING : 14.00mm.
 4. MINIMUM PCB THICKNESS : 1.57mm.
 5. USE OF HOLE IS OPTIONAL AND CAN BE ADDED WHEN ADDITIONAL MECHANICAL MOUNTING AND STRAIN RELIEF IS DEEMED NECESSARY.
 6. DETAILED INFORMATION OF "PINNING VIA" REFER TO APPLICATION SPECIFICATION GS-20-0356 SECTION 5
 7. CONNECTOR KEEP OUT AREA

spec ref	-	dr	Deborah Ingram	2012/04/10	projection	MM	size	A2	scale	4:1
tolerance std	ASME Y14.5	eng	Jacklin Zou	2015/12/09			ecn no	ELX-DG-22744-1		
TOLERANCES UNLESS OTHERWISE SPECIFIED		chr	Zhen Luo	2015/12/22				rel level	Released	
surface	✓	appr	Pei-Ming Zheng	2015/12/23	product family			INTERNAL VERTICAL ASSEMBLY Mini-SAS HD VERTICAL ASSEMBLY	dwg no 10120667	rev F
ASME Y14.5	linear	0.X	±0.25	www.fci.com	cat. no.	Product - Customer Drw		sheet 2 of 4		
	0.XX	±0.13								
	0.XXX	±								
	angular	0°	±1/2°							

Copyright FCI. FCI

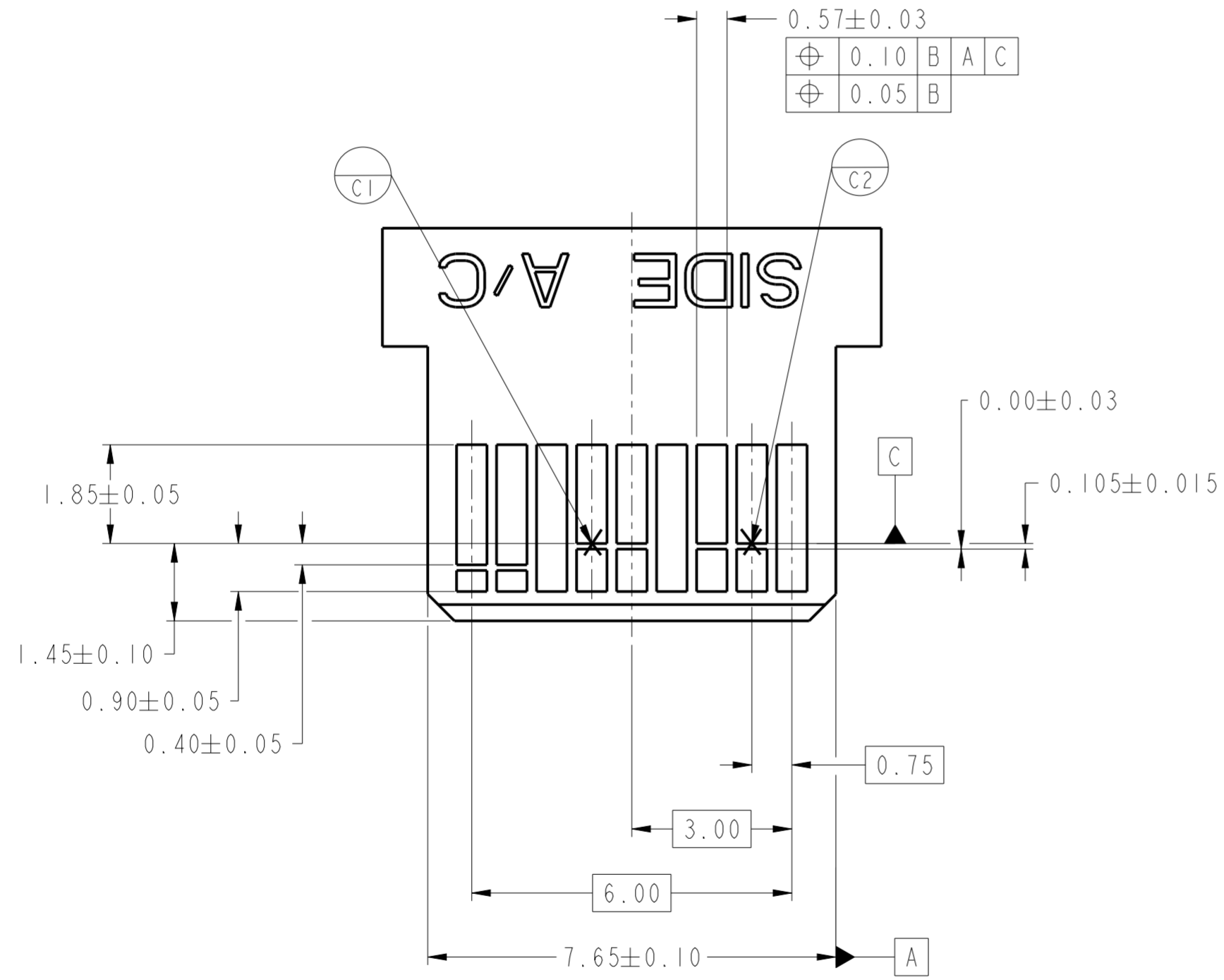
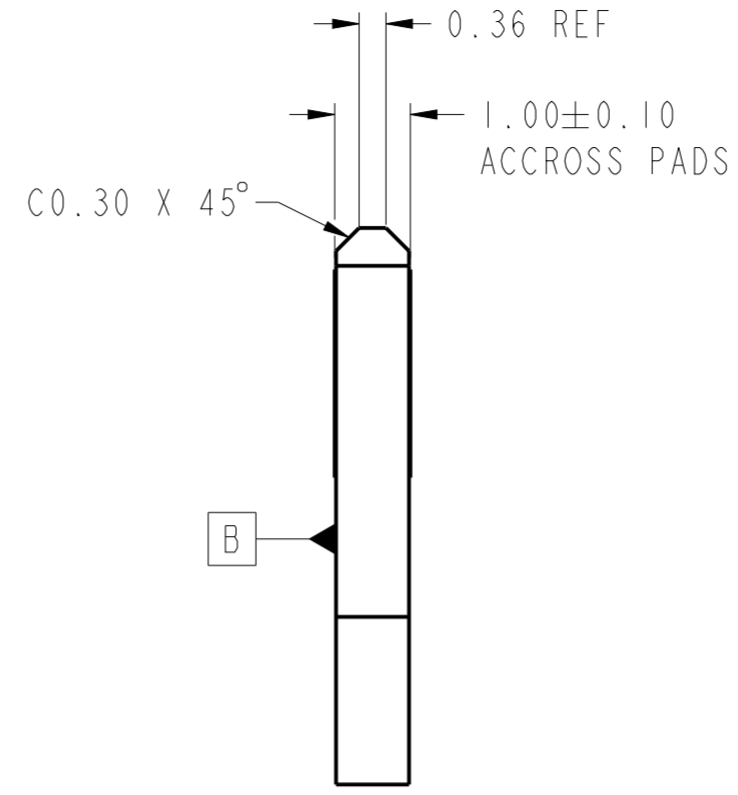
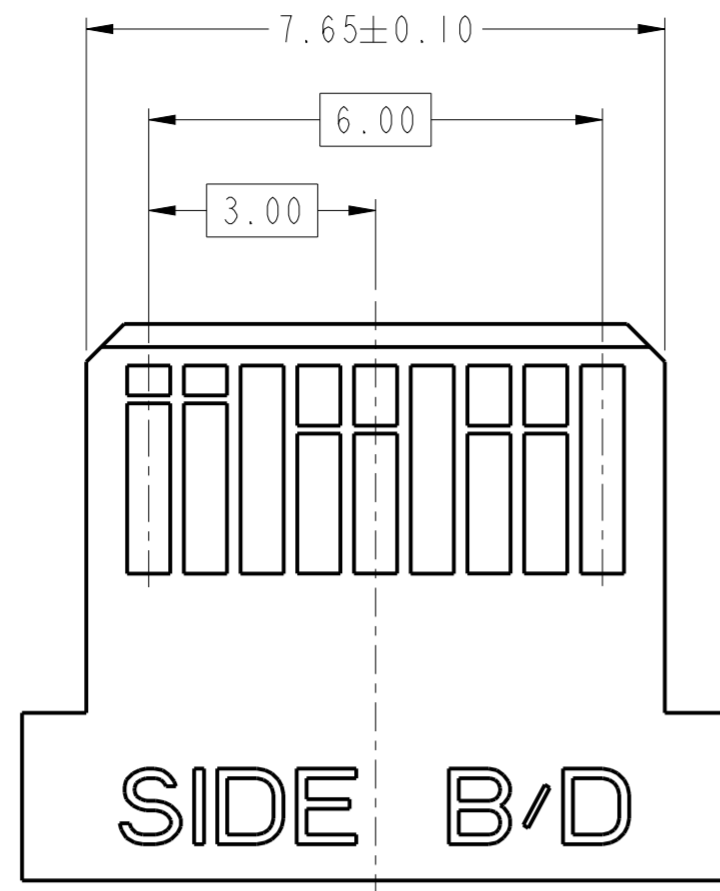

NOTES:

- 0.05 MINIMUM KEEP OUT SOLDER MASK AROUND ALL PADS.
- DATUM C TARGETS ARE DEFINED BY THE RESPECTIVE PAD CENTER LINES AND THE LEADING EDGE OF THE TARGET PADS.

spec ref	-	dr	Deborah Ingram	2012/04/10	projection	MM	size	A2	scale	4:1								
tolerance std	ASME Y14.5	eng	Jacklin Zou	2015/12/09			ecn no	ELX-DG-22744-1										
		chr	Zhen Luo	2015/12/22			rel level	Released										
surface	✓	appr	Pei-Ming Zheng	2015/12/23	product family	INTERNAL VERTICAL ASSEMBLY		dwg no	10120667									
ASME Y14.5	linear	<table border="1"> <tr> <td>0.X</td> <td>±0.25</td> </tr> <tr> <td>0.XX</td> <td>±0.13</td> </tr> <tr> <td>0.XXX</td> <td>±</td> </tr> </table>		0.X	±0.25	0.XX	±0.13	0.XXX	±		<table border="1"> <tr> <td>title</td> <td>INTERNAL VERTICAL ASSEMBLY</td> </tr> <tr> <td>Mini-SAS HD VERTICAL ASSEMBLY</td> <td></td> </tr> </table>	title	INTERNAL VERTICAL ASSEMBLY	Mini-SAS HD VERTICAL ASSEMBLY		<table border="1"> <tr> <td>rev</td> <td>F</td> </tr> </table>	rev	F
0.X	±0.25																	
0.XX	±0.13																	
0.XXX	±																	
title	INTERNAL VERTICAL ASSEMBLY																	
Mini-SAS HD VERTICAL ASSEMBLY																		
rev	F																	
ASME Y14.5	angular	0°	±1/2°	www.fci.com	cat. no.	Product - Customer Drw	sheet 3 of 4											

Copyright FCI. FCI

1 2 3 4 5 6 7 8

A B C D E F

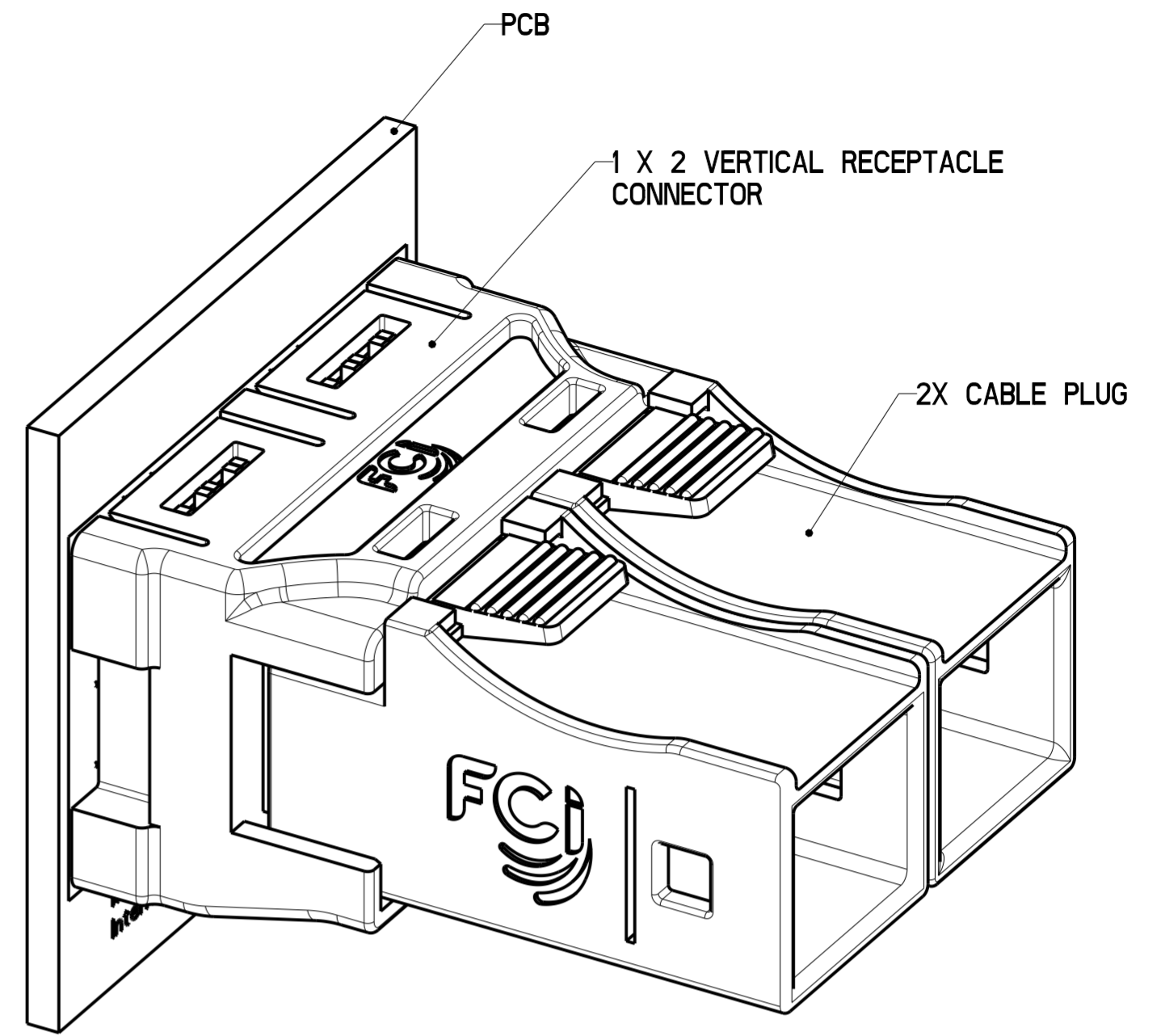
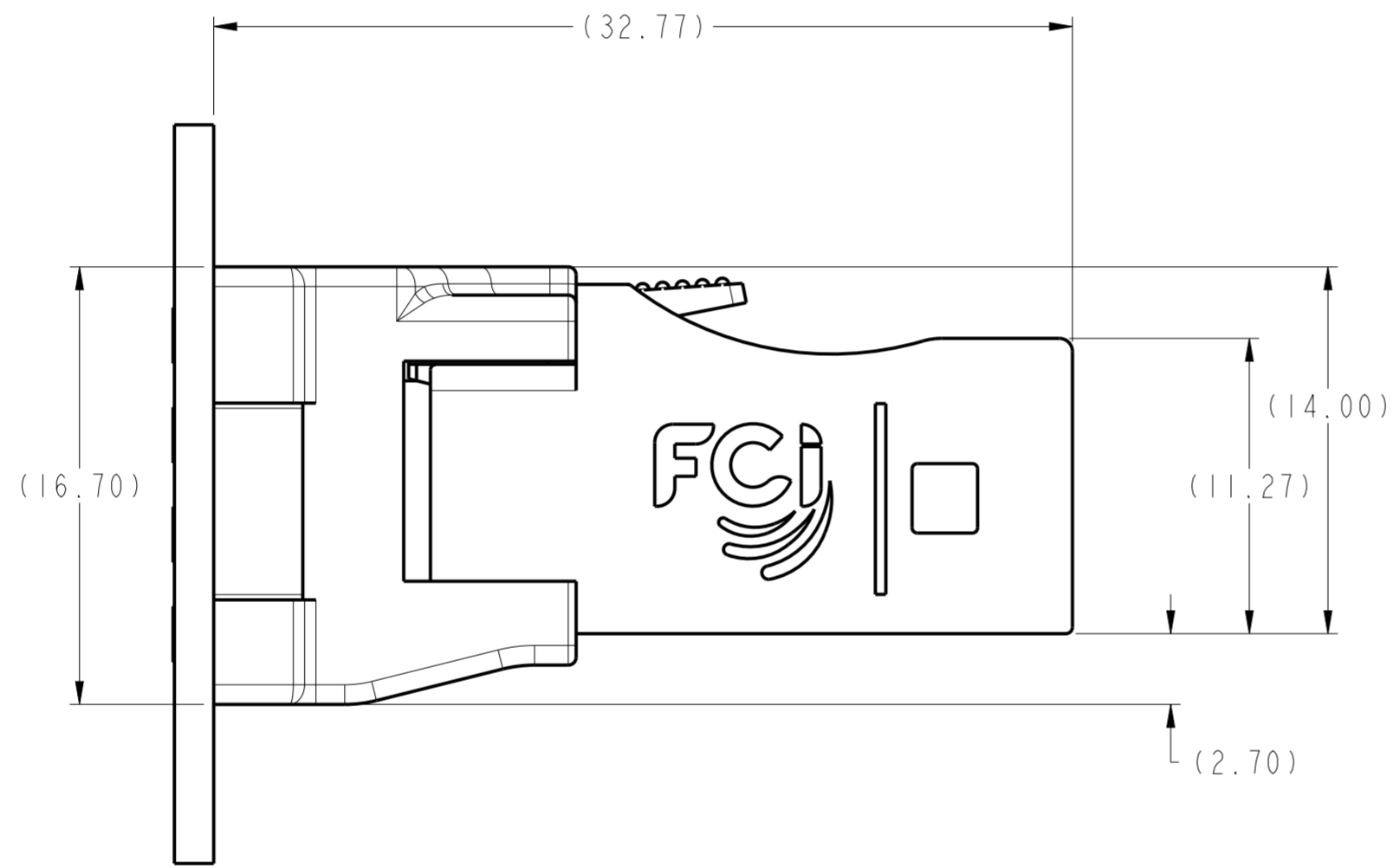

Copyright FCI. FCI

spec ref	-	dr	Deborah Ingram	2012/04/10	projection	MM	size	A2	scale	4:1
tolerance std	ASME Y14.5	eng	Jacklin Zou	2015/12/09			ecn no	ELX-DG-22744-1		
		chr	Zhen Luo	2015/12/22			rel level	Released		
		appr	Pei-Ming Zheng	2015/12/23	product family					
surface	✓	linear	0.X	±0.25		INTERNAL VERTICAL ASSEMBLY Mini-SAS HD VERTICAL ASSEMBLY	dwg no	10120667		
			0.XX	±0.13			rev	F		
		angular	0°	±1/2°			cat. no.	Product - Customer Drw sheet 4 of 4		