

THIS DRAWING IS UNPUBLISHED. RELEASED FOR PUBLICATION. ALL RIGHTS RESERVED.

LOC	DIST	REVISIONS			
P	LTR	DESCRIPTION	DATE	DWN	APVD
-	-	A	NEW RELEASE	03MAR2013	H.W. P.Y.
-	-	A1	REVISED	16OCT2013	H.W. X.X.

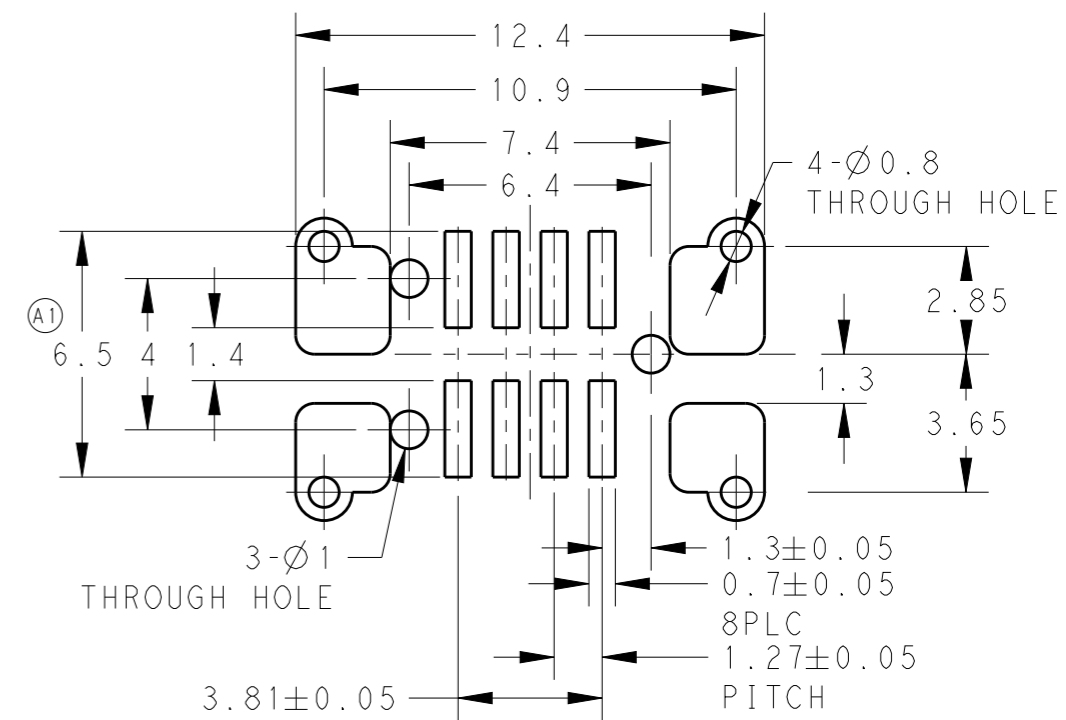

RECOMMENDED BOARD DIMENSION
t=1.6
SCALE 5:1
GENERAL TOL.: ±0.1

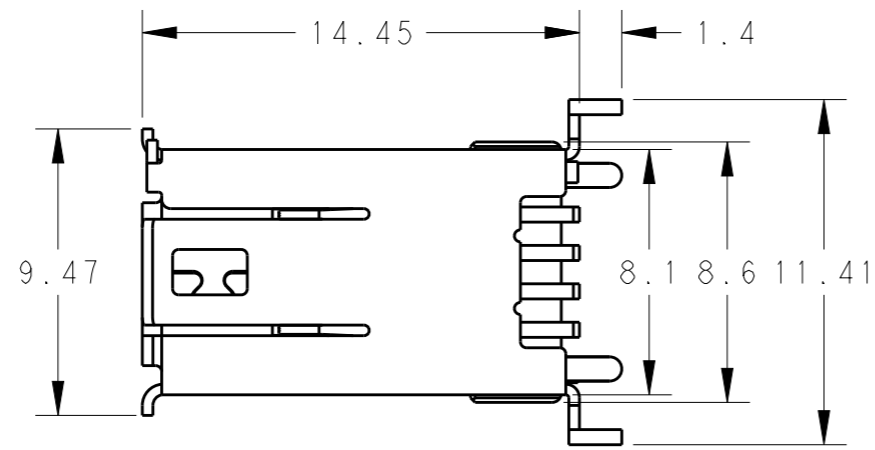
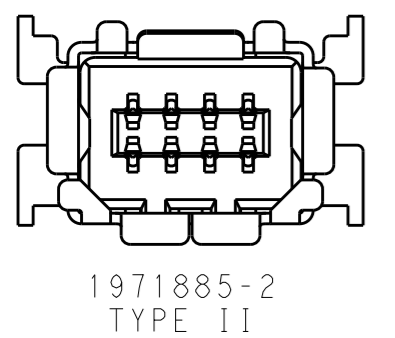
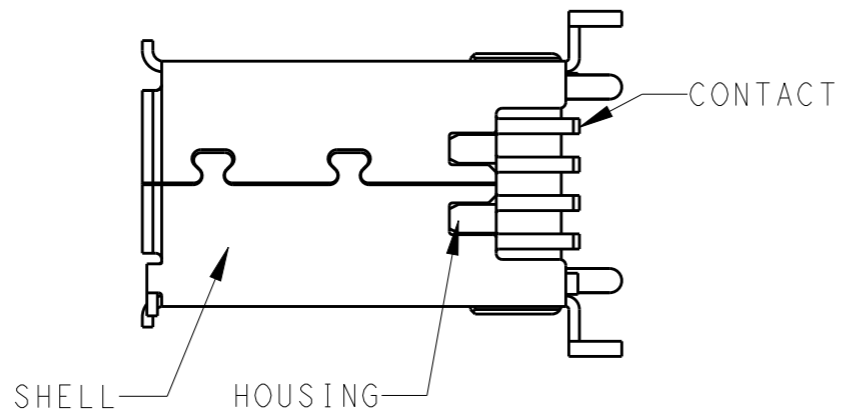
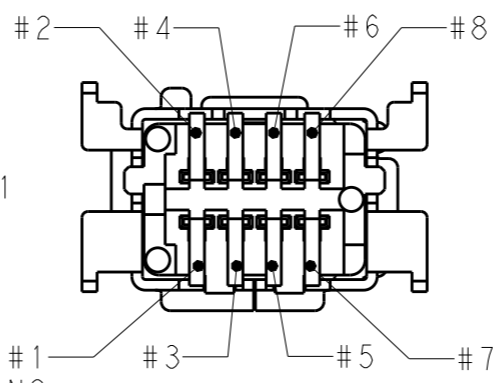
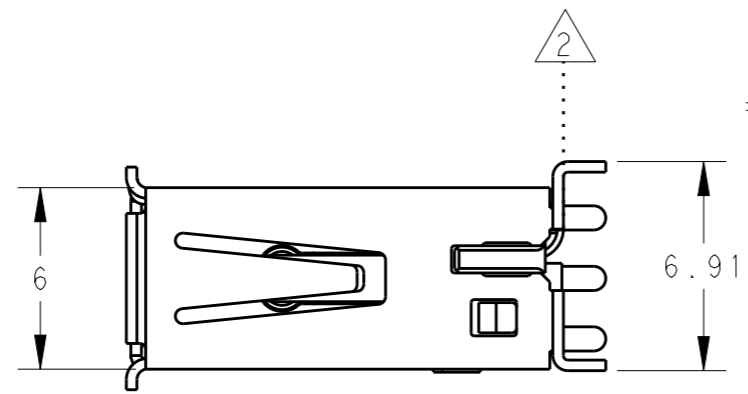
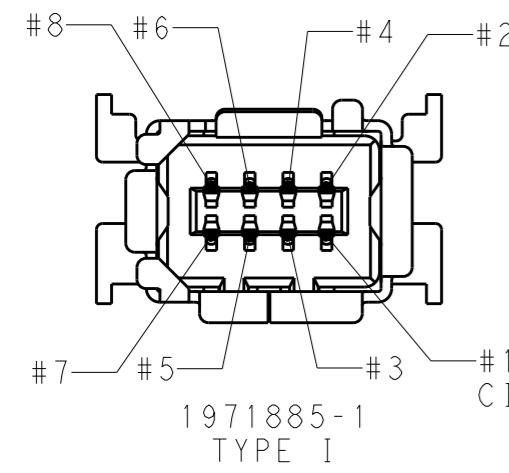

NOTES:
1 MATERIAL AND FINISH
CONTACT: COPPER ALLOY
UNDER ALL SURFACE NICKEL 1.27µm MIN.
TOP CONTACT AREA: GOLD 0.5µm MIN
SOLDERING AREA: TIN PLATE
HOUSING: THERMO PLASTIC(UL94V-0)
SHELL: COPPER ALLOY
UNDER ALL SURFACE NICKEL
TOP ALL SURFACE TIN
2 COPLANARITY 0.1 MAX
(IN 8 TIPS OF CONTACTS AND 4 PEGS OF SHELL)
3 GENERAL TOL.: ±0.3; ±5°

8	TYPE II SMT RECEPTACLE WITH CAP	1-1971885-2
8	TYPE I SMT RECEPTACLE WITH CAP	1-1971885-1
8	TYPE II SMT RECEPTACLE	1971885-2
8	TYPE I SMT RECEPTACLE	1971885-1
POS	DESCRIPTION	PART NO

THIS DRAWING IS A CONTROLLED DOCUMENT.		DWN 03MAR2013 HOWELL WANG	TE Connectivity	
DIMENSIONS: mm		CHK 03MAR2013 DAVID WANG		
TOLERANCES UNLESS OTHERWISE SPECIFIED:		APVD 03MAR2013 PETER YIN	NAME SMT VERTICAL MINI I/O RECEPTACLE 1.27mm PITCH	
0 PLC ±-		PRODUCT SPEC 108-106087	SIZE A3	CAGE CODE -
1 PLC ±-		APPLICATION SPEC -	DRAWING NO C-1971885	RESTRICTED TO -
2 PLC ±-		WEIGHT -	SCALE 4:1 SHEET 1 OF 3 REV A1	
3 PLC ±-		Customer Drawing		
4 PLC ±-				
ANGLES ±-				
FINISH -				

THIS DRAWING IS UNPUBLISHED. RELEASED FOR PUBLICATION
 © COPYRIGHT - BY - ALL RIGHTS RESERVED.

LOC	DIST	REVISIONS			
P	LTR	DESCRIPTION	DATE	DWN	APVD
-	-	SEE SHEET 1	-	-	-

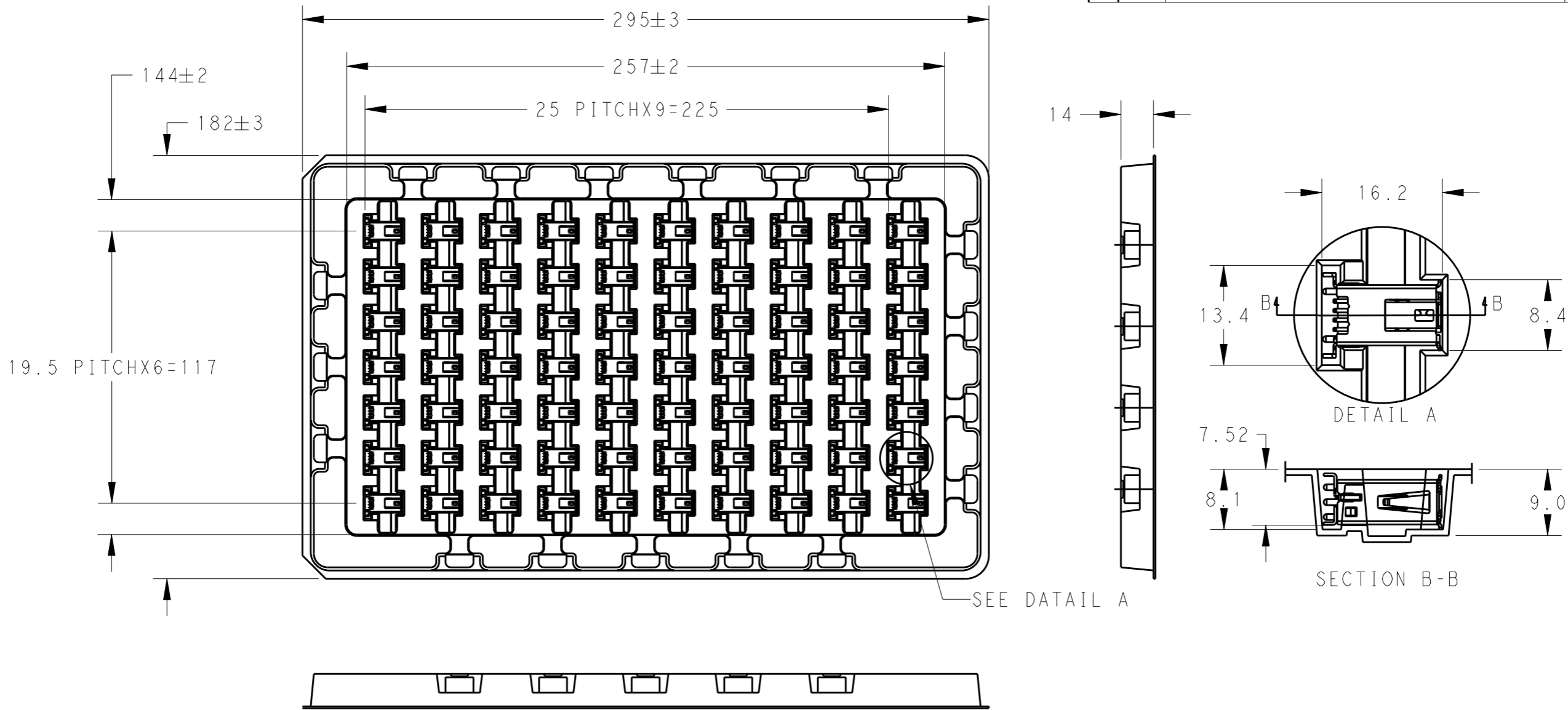

SEE DETAIL A

PACKAGE AS SHOWN	1971885-2 1971885-1
DESCRIPTION	PART NO

NOTE:
 4 PACKAGE:
 70PCS PER TRAY FOR 1971885-1 & 1971885-2

THIS DRAWING IS A CONTROLLED DOCUMENT.		DWN	SEE SHEET 1	TE Connectivity NAME SMT VERTICAL MINI I/O RECEPTACLE 1.27mm PITCH			
DIMENSIONS: mm		CHK	SEE SHEET 1				
TOLERANCES UNLESS OTHERWISE SPECIFIED:		APVD	SEE SHEET 1				
0 PLC ±- 1 PLC ±- 2 PLC ±- 3 PLC ±- 4 PLC ±- ANGLES ±-		PRODUCT SPEC	SEE SHEET 1				
MATERIAL	FINISH	APPLICATION SPEC	-	SIZE	CAGE CODE	DRAWING NO	RESTRICTED TO
-	-	WEIGHT	-	A3	-	©-1971885	-
Customer Drawing				SCALE	4:1	SHEET	2 OF 3
				REV	A1		

THIS DRAWING IS UNPUBLISHED. RELEASED FOR PUBLICATION
 © COPYRIGHT - BY - ALL RIGHTS RESERVED.

LOC	DIST	REVISIONS			
P	LTR	DESCRIPTION	DATE	DWN	APVD
-	-	SEE SHEET 1	-	-	-

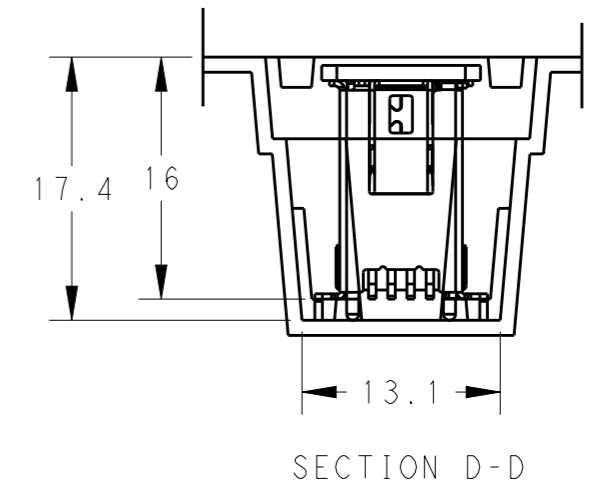
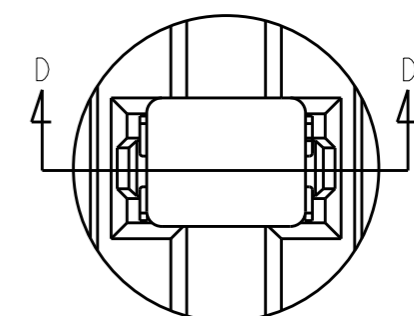
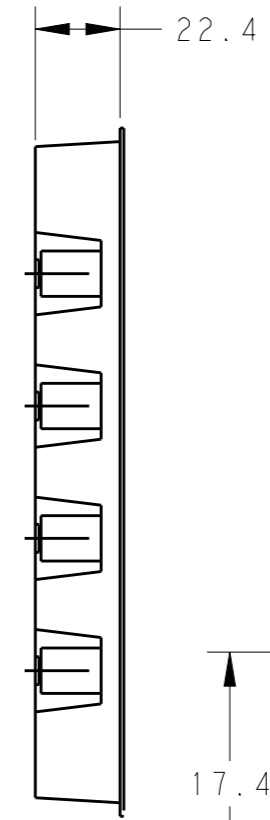
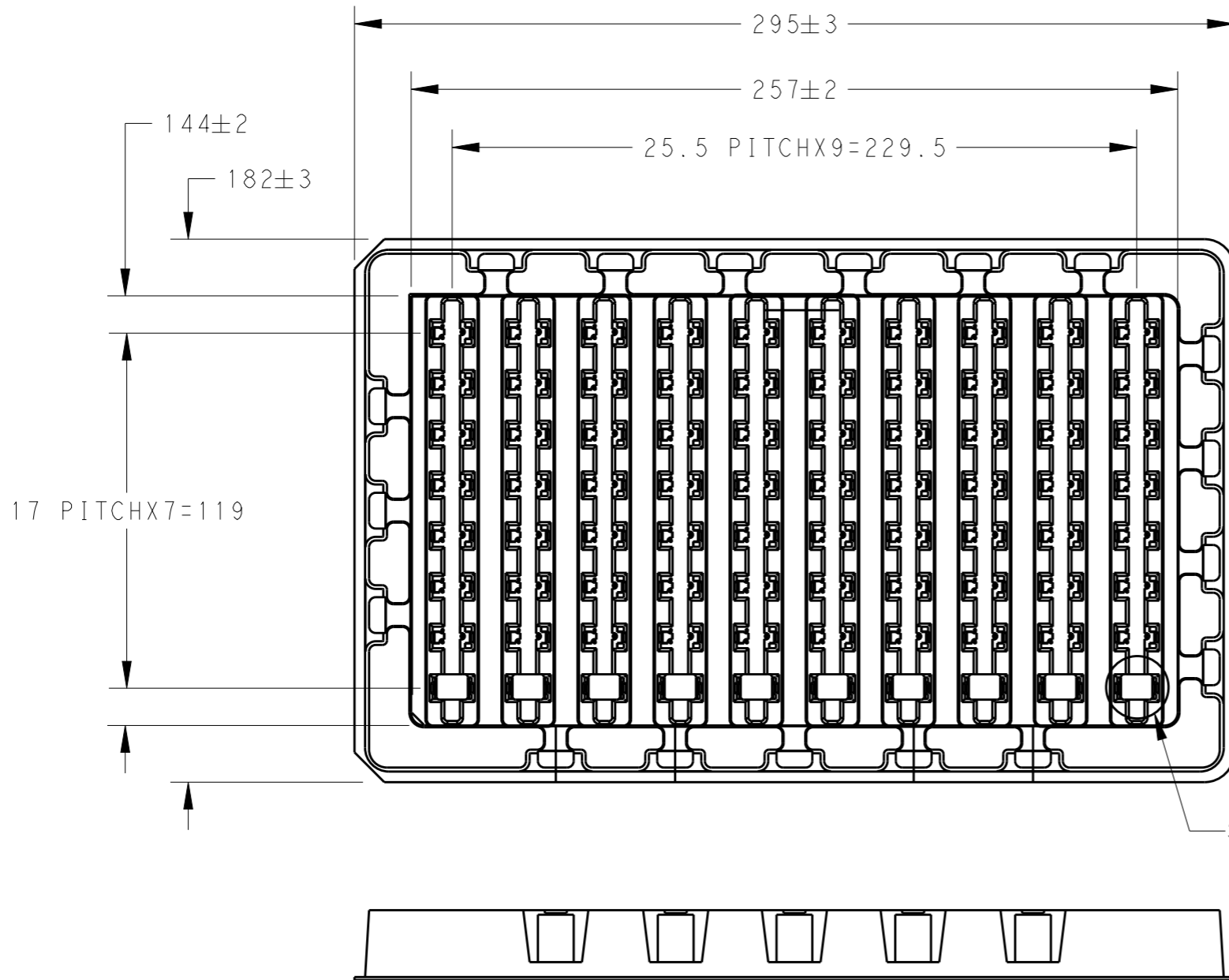

SEE DATA C

NOTE:
 5 PACKAGE:
 80PCS PER TRAY FOR 1-1971885-1 & 1-1971885-2

PACKAGE AS SHOWN	1-1971885-2 1-1971885-1
DESCRIPTION	PART NO

THIS DRAWING IS A CONTROLLED DOCUMENT.		DWN	SEE SHEET 1	 TE Connectivity NAME SMT VERTICAL MINI I/O RECEPTACLE 1.27mm PITCH			
DIMENSIONS: mm		CHK	SEE SHEET 1				
TOLERANCES UNLESS OTHERWISE SPECIFIED:		APVD	SEE SHEET 1				
0 PLC ± - 1 PLC ± - 2 PLC ± - 3 PLC ± - 4 PLC ± - ANGLES ± -		PRODUCT SPEC	SEE SHEET 1				
MATERIAL	FINISH	APPLICATION SPEC	-	SIZE	CAGE CODE	DRAWING NO	RESTRICTED TO
-	-	WEIGHT	-	A3	-	©-1971885	-
Customer Drawing				SCALE	SHEET	3 OF 3	REV A1

Mouser Electronics

Authorized Distributor

Click to View Pricing, Inventory, Delivery & Lifecycle Information:

[TE Connectivity:](#)

[1971885-1](#)