

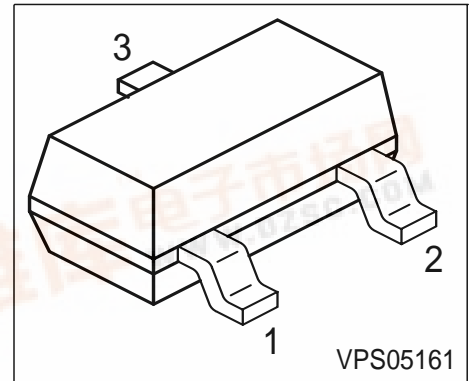

BSS79, BSS81

NPN Silicon Switching Transistors

- High DC current gain: 0.1mA to 500 mA
- Low collector-emitter saturation voltage
- Complementary types: BSS80, BSS82 (PNP)



Type	Marking	Pin Configuration			Package
BSS79B	CEs	1 = B	2 = E	3 = C	SOT23
BSS79C	CFs	1 = B	2 = E	3 = C	SOT23
BSS81B	CDs	1 = B	2 = E	3 = C	SOT23
BSS81C	CGs	1 = B	2 = E	3 = C	SOT23

Maximum Ratings

Parameter	Symbol	BSS79	BSS81	Unit
Collector-emitter voltage	V_{CEO}	40	35	V
Collector-base voltage	V_{CBO}	75		V
Emitter-base voltage	V_{EBO}	6		
DC collector current	I_C	800		mA
Peak collector current	I_{CM}	1		A
Base current	I_B	100		mA
Peak base current	I_{BM}	200		
Total power dissipation, $T_S = 77\text{ °C}$	P_{tot}	330		mW
Junction temperature	T_j	150		°C
Storage temperature	T_{stg}	-65 ... 150		

Thermal Resistance

Junction - soldering point ¹⁾	R_{thJS}	≤220	K/W
--	------------	------	-----

¹⁾For calculation of R_{thJA} please refer to Application Note Thermal Resistance

Electrical Characteristics at $T_A = 25^\circ\text{C}$, unless otherwise specified.

Parameter	Symbol	Values			Unit
		min.	typ.	max.	
DC Characteristics					
Collector-emitter breakdown voltage $I_C = 10\text{ mA}, I_B = 0$	$V_{(BR)CEO}$				V
BSS79		40	-	-	
BSS81		35	-	-	
Collector-base breakdown voltage $I_C = 10\text{ }\mu\text{A}, I_E = 0$	$V_{(BR)CBO}$	75	-	-	
Emitter-base breakdown voltage $I_E = 10\text{ }\mu\text{A}, I_C = 0$	$V_{(BR)EBO}$	6	-	-	
Collector cutoff current $V_{CB} = 60\text{ V}, I_E = 0$	I_{CBO}	-	-	10	nA
Collector cutoff current $V_{CB} = 60\text{ V}, I_E = 0, T_A = 150\text{ }^\circ\text{C}$	I_{CBO}	-	-	10	μA
Emitter cutoff current $V_{EB} = 3\text{ V}, I_C = 0$	I_{EBO}	-	-	10	nA
DC current gain 1) $I_C = 100\text{ }\mu\text{A}, V_{CE} = 10\text{ V}$	h_{FE}				-
BSS79/81B		20	-	-	
BSS79/81C		35	-	-	
$I_C = 1\text{ mA}, V_{CE} = 10\text{ V}$					
BSS79/81B		25	-	-	
BSS79/81C		50	-	-	
$I_C = 10\text{ mA}, V_{CE} = 10\text{ V}$					
BSS79/81B		35	-	-	
BSS79/81C		75	-	-	
$I_C = 150\text{ mA}, V_{CE} = 10\text{ V}$					
BSS79/81B		40	-	120	
BSS79/81C		100	-	300	
$I_C = 500\text{ mA}, V_{CE} = 10\text{ V}$					
BSS79/81B		25	-	-	
BSS79/82C		40	-	-	
Collector-emitter saturation voltage1) $I_C = 150\text{ mA}, I_B = 15\text{ mA}$	V_{CEsat}				V
$I_C = 500\text{ mA}, I_B = 50\text{ mA}$		-	-	0.3	
		-	-	1.3	
Base-emitter saturation voltage 1) $I_C = 150\text{ mA}, I_B = 15\text{ mA}$	V_{BEsat}				
$I_C = 500\text{ mA}, I_B = 50\text{ mA}$		-	-	1.2	
		-	-	2.0	

 1) Pulse test: $t \leq 300\text{ }\mu\text{s}$, $D = 2\%$

Electrical Characteristics at $T_A = 25^\circ\text{C}$, unless otherwise specified.

Parameter	Symbol	Values			Unit
		min.	typ.	max.	
AC Characteristics					
Transition frequency $I_C = 20\text{ mA}$, $V_{CE} = 20\text{ V}$, $f = 100\text{ MHz}$	f_T	-	250	-	MHz
Collector-base capacitance $V_{CB} = 10\text{ V}$, $f = 1\text{ MHz}$	C_{cb}	-	6	-	pF
Delay time $V_{CC} = 30\text{ V}$, $I_C = 150\text{ mA}$, $I_{B1} = 15\text{ mA}$, $V_{BE(off)} = 0.5\text{ V}$	t_d	-	-	10	ns
Rise time $V_{CC} = 30\text{ V}$, $I_C = 150\text{ mA}$, $I_{B1} = 15\text{ mA}$, $V_{BE(off)} = 0.5\text{ V}$	t_r	-	-	25	
Storage time $V_{CC} = 30\text{ V}$, $I_C = 150\text{ mA}$, $I_{B1} = I_{B2} = 15\text{ mA}$	t_{stg}	-	-	250	
Fall time $V_{CC} = 30\text{ V}$, $I_C = 150\text{ mA}$, $I_{B1} = I_{B2} = 15\text{ mA}$	t_f	-	-	60	

Test circuits

Delay and rise time

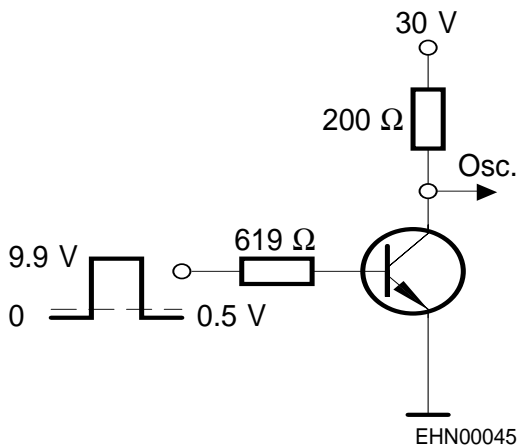

Storage and fall time

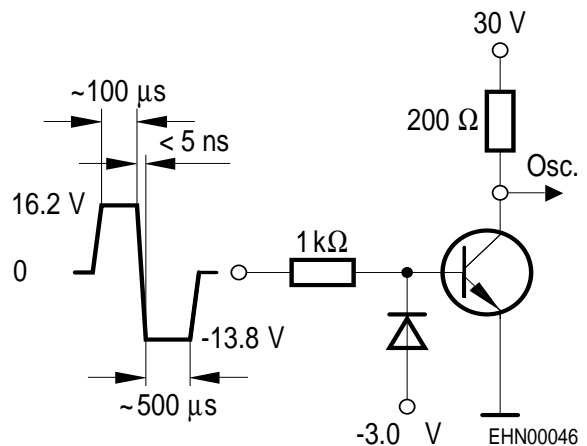

Oscilloscope: $R > 100\text{k}\Omega$
 $C < 12\text{pF}$
 $t_r < 5\text{ns}$

Total power dissipation $P_{tot} = f(T_S)$

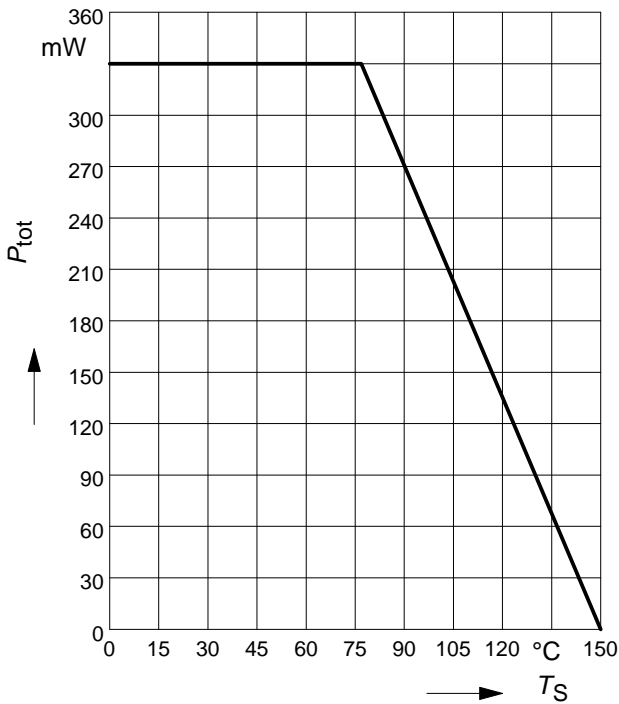

Collector-base capacitance $C_{CB} = f(V_{CB})$

$f = 1\text{MHz}$

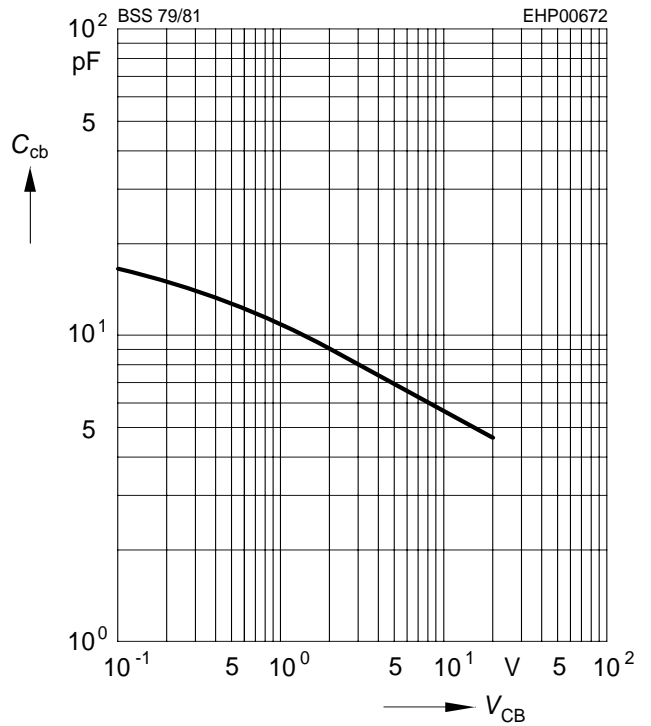

Permissible pulse load

$P_{totmax} / P_{totDC} = f(t_p)$

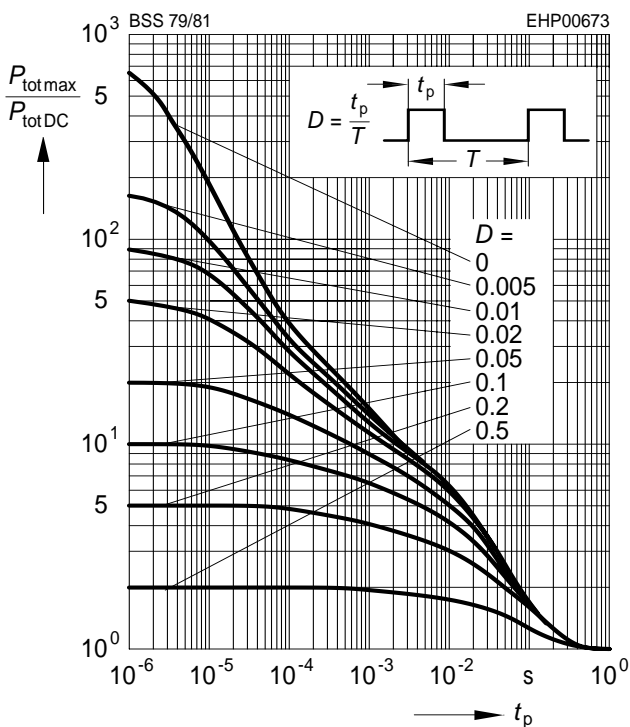

Transition frequency $f_T = f(I_C)$

$V_{CE} = 20\text{V}$

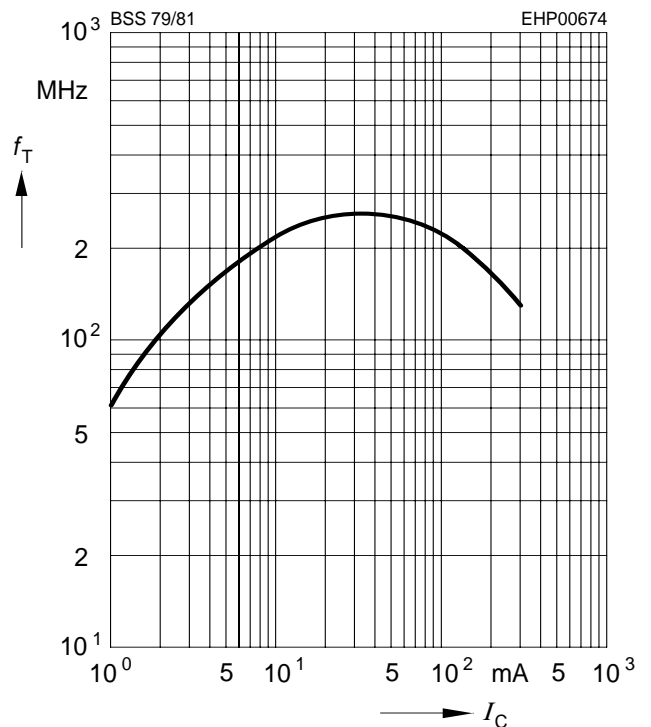

Saturation voltage $I_C = f(V_{BEsat}, V_{CEsat})$
 $h_{FE} = 10$

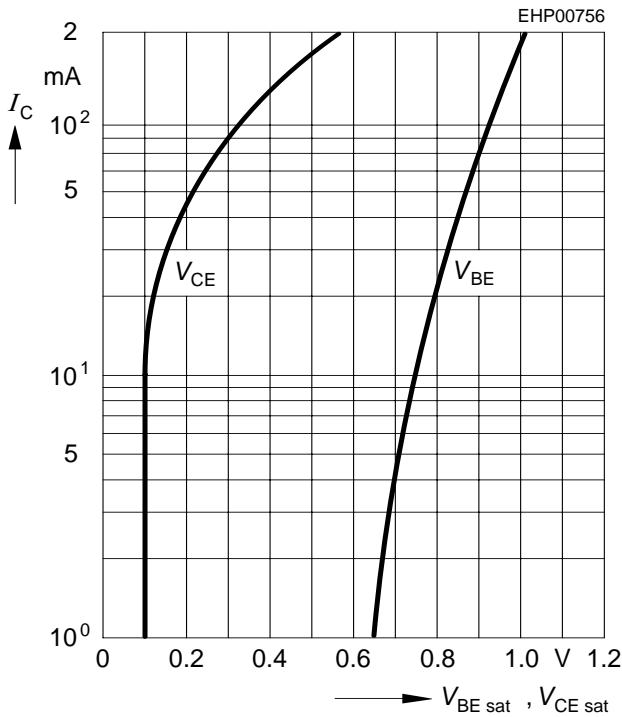

DC current gain $h_{FE} = f(I_C)$
 $V_{CE} = 10V$

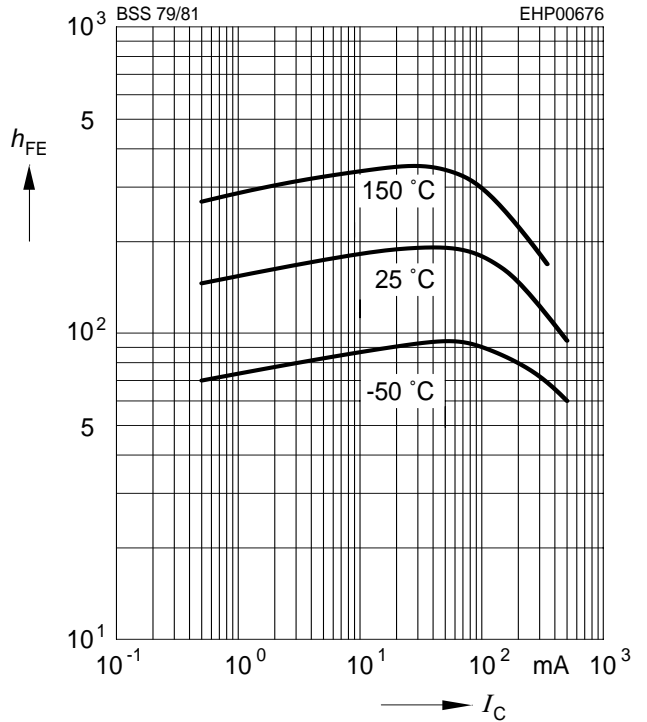

Delay time $t_d = f(I_C)$
Rise time $t_r = f(I_C)$

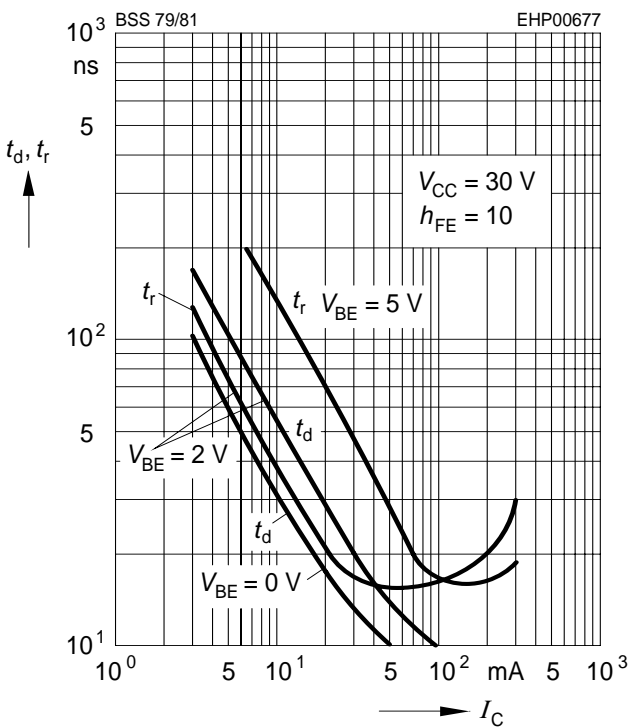

Storage time $t_{stg} = f(I_C)$
Fall time $t_f = f(I_C)$

