



har-flexicon 2.54

PCB print terminal block, horizontal



General information

Design	PCB print terminal block, horizontal	
No. of contacts	2-12 poles	
Contact pitch	2,54 mm	
Test voltage	2,5 kV	
Rated voltage	160 V	overvoltage category III / pollution degree 2
Contact resistance	max. 20mOhm	
Insulation resistance	min. 10 ⁹ Ohm	
Working current	8,4 A at 70°C (tested with AWG20, see derating diagram)	
Temperature range	-40°C ... +125°C	
Termination technology	Push-In spring cage	
Reflow processing temperature	20s at 255°C	
Clearance & creepage distance	Clearance: 1,5 mm	Creepage: 1,6 mm
Hot plugging	No	
vibration	5-150Hz, 0,35mm, 5g, 2h each axis	

RoHS - compliant	Yes
UL file	pending

Insulator material

Material	LCP (liquid crystalline polymer, glass fiber reinforcement 30%)
Color	black
UL classification	UL 94-V0
Material group acc. IEC 60664-1	IIIa (175 < CTI < 400)
NFF classification	-

Contact material

Contact material	Copper alloy
Plating termination zone	Sn
Plating contact zone	Sn

Derating diagram acc. to IEC 60512-5 (Current carrying capacity)

The current carrying capacity is limited by maximum temperature of materials for inserts and contacts including terminals.

The current capacity curve is valid for continuous, non interrupted current loaded contacts of connectors when simultaneous power on all contacts is given, without exceeding the maximum temperature.

Control and test procedures according to DIN IEC 60512-5

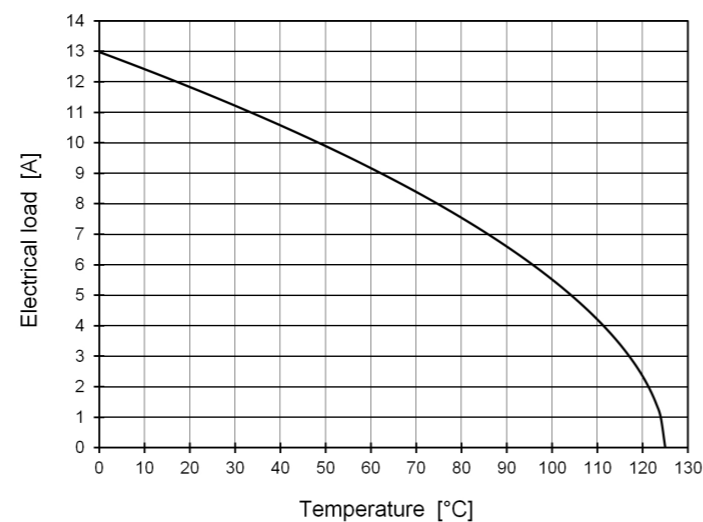

tested with AWG20

Connection data

Conductor cross section solid min./max.	0.14mm ² / 0.5mm ²
Conductor cross section stranded min./max.	0.2mm ² / 0.5mm ²
Conductor cross section stranded, with ferrule, min./max.	0.25mm ² / 0.34mm ²
Minimum AWG	26
Maximum AWG	20
Stripping length	6 mm
Reconnection	10 times (only with same or larger cross section)

Recommended tools

part number	14990000001
-------------	-------------

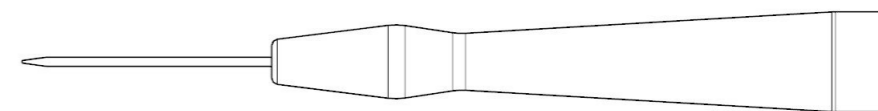

	All rights reserved	Created by	Inspected by	Standardisation	Date	State	
	Department EC PD - DE	HASSE	FRIESENH	KOHLER	2013-10-09	Final Release	
HARTING Electronics GmbH		Title har-flexicon 2.54, print terminal block, horizontal				Doc-Key / ECM-Nr. 100550629/UGD/001/A 500000067057	
D-32339 Espelkamp		Type	Number		Rev.	Page	
		DS	14017301601		A	1/2	



har-flexicon 2.54 PCB print terminal block, horizontal



packaging & tape layout

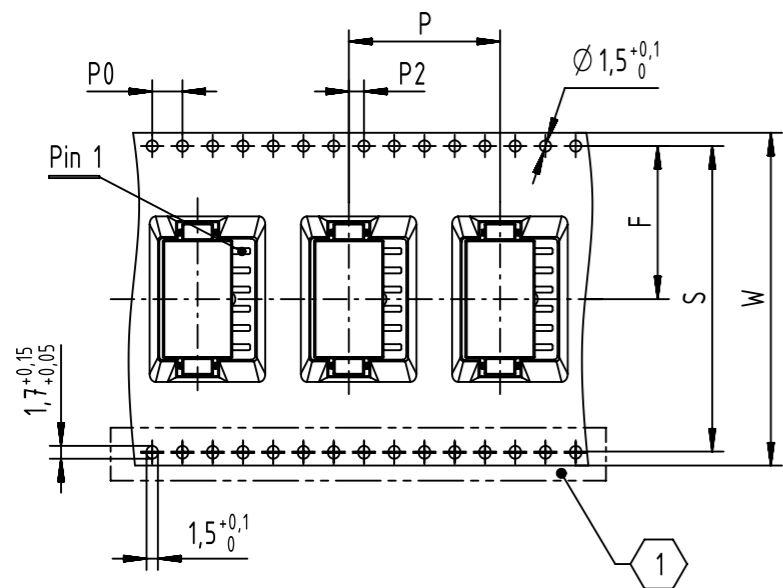

pole	W [mm]	F [mm]	S [mm]	P2 [mm]	P [mm]	P0 [mm]
2	24,0 ^{+0,3} _{-0,1}	11,5 ± 0,1		2,0 ± 0,1	20,0 ± 0,1	4,0 ± 0,1
3						
4	32,0 ± 0,3	14,2 ± 0,1	28,4 ± 0,1	2,0 ± 0,1	20,0 ± 0,1	4,0 ± 0,1
5						
6						
7						
8	44,0 ± 0,3	20,2 ± 0,1	40,4 ± 0,1	2,0 ± 0,15	20,0 ± 0,1	4,0 ± 0,1
9						
10						
11	56,0 ± 0,3	26,2 ± 0,1	52,4 ± 0,1	2,0 ± 0,15	20,0 ± 0,1	4,0 ± 0,1
12						

1 no double sprocket holes for 2- and 3-pole numbers

Reel dimensions

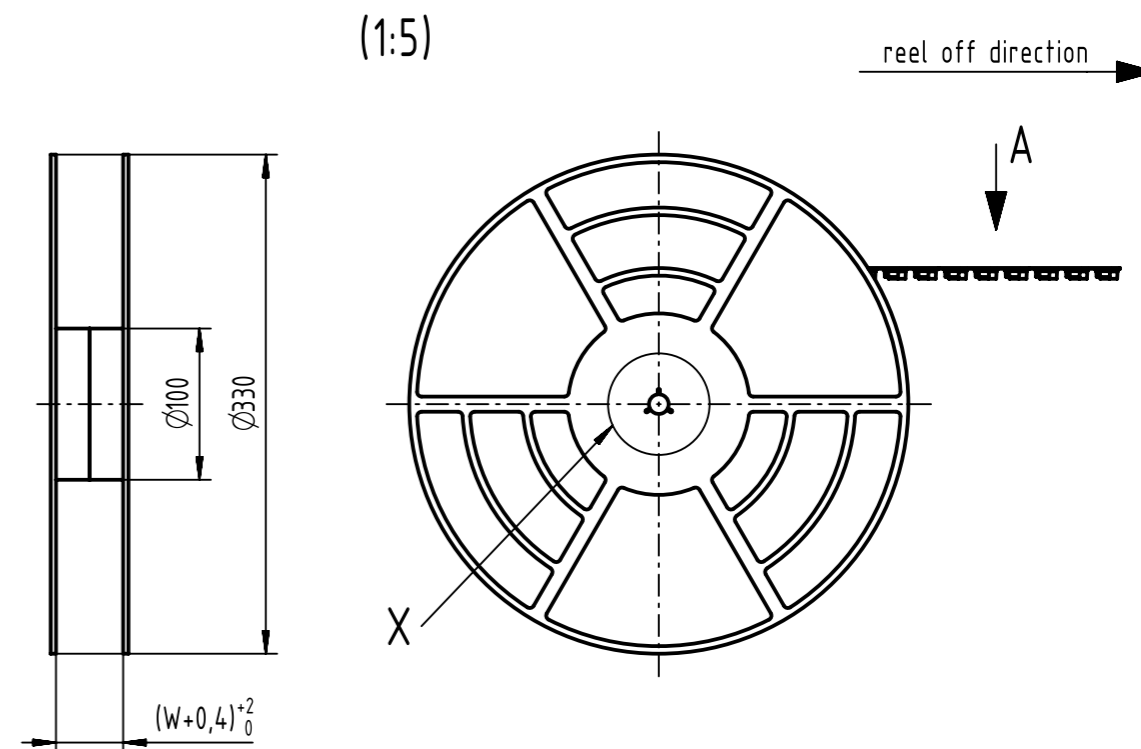

X (1:1)

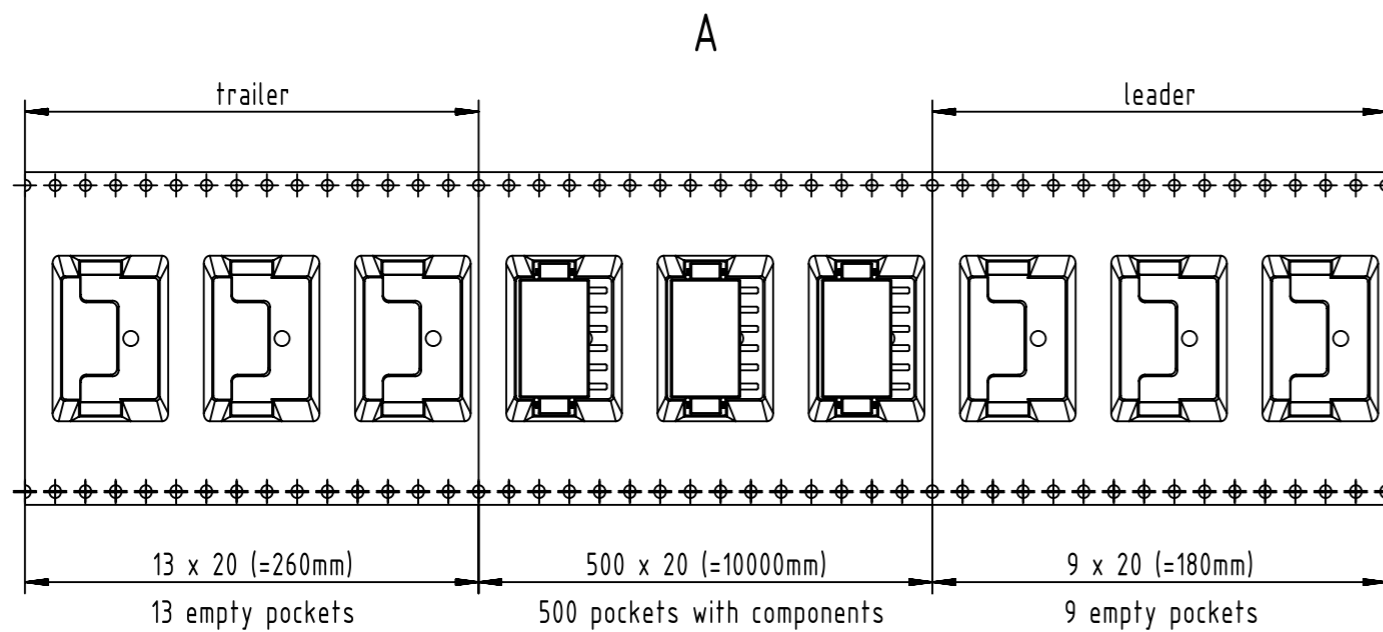
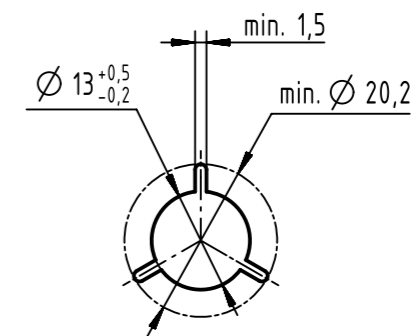

Packaging	Index
tape and reel with 500 pcs per reel	000
tape with 1 pcs	333

part-number	1401XX13102XXX
-------------	----------------

	All rights reserved Department EC PD - DE	All Dimensions in mm Original Size DIN A3		Scale 1:1	Free size tol.	Ref. Sub.
		Created by HASSE	Inspected by FRIESENH	Standardisation KOHLER	Date 2013-10-09	State Final Release
HARTING Electronics GmbH D-32339 Espelkamp		Title har-flexicon 2.54, print terminal block, horizontal			Doc-Key / ECM-Nr. 100550629/UGD/001/A 50000067057	
		Type DS	Number 14017301601		Rev. A	Page 2/2