

FASTON\* Connector Terminal, Receptacle Contact  
2,8-4,8-5,0-6,3-9,5 mm. Series, Straight Version

## 1. SCOPE

This specification covers the performance requirements for FASTON\* Connector Receptacle Contacts, Straight Version.

Sizes are designed to correspond to the mating tab width of 2.8 - 4.8 - 5.0 - 6.3 - 9.5 mm. acc. to the IEC 760.

These terminals are suitable for Automotive, Consumer Goods, Computer, Telecommunications and Industrial Controllers Applications.

## 2. REQUIREMENTS

### 2.1 Design and construction

Connectors shall be of the design, construction and physical dimensions specified on the applicable product drawings, called Customer drawing (C-.... Amp Part Number)

### 2.2 Materials

Brass, spec.# 100-86, plain, or tin plated, or silver plated.

Phosphor Bronze, spec.# 100-221, plain, or tin plated, or silver plated.

Steel, spec.# 100-021, nickel plated.

### 2.3 Application of the FASTON\* terminal

Crimp height must be in accordance with the dimensions specified on the relevant Application Spec., on plate of the relevant mini-applicator, or the Instruction Sheet of the hand tool.

### 2.4 Current Carrying Capacity

2.8 mm. (.110" Sr.)	14 A max with 1.5 mm <sup>2</sup> wire size
4.8 (&5.0) mm. (.187"&.197" Sr.)	20 A max with 2.5 mm <sup>2</sup> wire size
6.3 mm. (.250" Sr.)	28 A max with 4 or 6 mm <sup>2</sup> wire size
	For steel nickel plated version use: 16 A max with 2.5 mm <sup>2</sup> wire or 10 A max with 1.5 mm <sup>2</sup> wire.
9.5 mm. (.375" Sr.)	50 A max with 10 mm <sup>2</sup> wire size

### 2.5 Operating conditions

Maximum operating temperature, including the temperature increasing due to working current flow :

- + 90°C Plain connection
- + 105°C Tin Plated connection
- + 130°C Silver Plated connection
- + 250°C Steel, Nickel Plated connection

Product Code: 1110

E2	REVISED FOR ET00-0003-05	H.Y.	05 JAN 2005	G.T.	05 JAN 2005
E1	REVISED FOR ET00-0059-01	H.Y.	20 FEB 2001	C.T.	20 FEB 2001
E	REVISED FOR ET00-0238-00	H.Y.	21 SEP 2000	C.T.	21 SEP 2000
D	REVISED FOR ET00-0381-99	H.Y.	05 JAN 2000	C.T.	05 JAN 2000
C	ADDED TEST SEQUENCE TABLE FOR ET00-0326-99	H.Y.	15 OCT 1999	C.T.	15 OCT 1999
B	REVISED, ET00-0258-99	R.F.	28 JUL 1999	C.T.	28 JUL 1999
A	REVISED & ACTIVATED, ET00-0058-99	H.Y.	22 FEB 1999	C.T.	22 FEB 1999
rev letter	rev. record	DR	Date	CHK	Date
DR. H. YAALI	DATE	APVD C. TARTARI	DATE		

This specification is a controlled document.

This information is confidential and is disclosed to you on condition that no further disclosure is made by you to other than AMP personnel without written authorization from AMP Italia.

**2.6 Preferred relationship between the cross-sectional area of the conductors and the nominal width of male tabs**

- 0.3 to 1.5 mm<sup>2</sup> : 2.8 - 4.8 (&5.0) - 6.3 mm.
- 0.3 to 2.5 mm<sup>2</sup> : 4.8 (&5.0)- 6.3 mm.
- 0.3 to 6.0 mm<sup>2</sup> : 6.3 mm.
- 4.0 to 10 mm<sup>2</sup> : 9.5 mm.

**2.7 Performance and Test Description**

Terminals shall be designed to meet the electrical, mechanical and environmental performance requirements below specified.

Unless otherwise specified, all measurements and tests shall be made at :

Room temperature : 23±5°C, Relative humidity : 45÷75%, Atmospheric pression : 800±1000 Bar.

**3. TEST REQUIREMENTS AND PROCEDURE SUMMARY**

TEST DESCRIPTION		PROCEDURE		REQUIREMENT		
3.1	Examination of the product	Visual inspection, dimensional and material control.		Meets requirements of Product Drawing (see para 2.1)		
3.2	Millivolt drop specified current	Measured between mating and wire, crimped on Faston* Connector receptacle, including 10 mm. length of the wire.		Millivolt drop required (without 10 mm. mV drop of the wire)		
		WIRE SECTION (mm <sup>2</sup> )	TEST CURRENT (A)			
		0.3 ÷ 0.35	3	18 mV max		
		0.5	5	18 mV max		
		0.75 ÷ 0.80	8	20 mV max		
		1	10	20 mV max		
		1.5	14	25 mV max		
		2.5	20	30 mV max		
		4	28	35 mV max		
		6	36	40 mV max		
10	50	80 mV max				
3.3	Mating force See also notes 2), 3)	Terminal FASTON* Connector rec to be mated with plain test tab, according to IEC 760, at a 50 mm/minute speed.  NOTE: Use plain steel tab for Steel rec. versions.		TAB SIZE (mm)	FIRST INSERTION (N)	
				2.8	60 max	
				4.8 (&5.0)	70 max	
				6.3	80 max	
				9.5	100 max	
3.4	Unmating force See also notes 2), 3)	Terminal FASTON* Connector Rec to be unmated with plain test tab , according to IEC 760, at a 50 mm/minute speed.  NOTE: Use plain steel tab for Steel rec. versions.		TAB SIZE (mm)	FIRST EXTRACTION (N)	TENTH EXTRACTION (N)
				2.8	60 max	10 min
				4.8 (&5.0)	70 max	15 min
				6.3	80 max	20 min
				9.5	100 max	30 min

TEST DESCRIPTION		PROCEDURE	REQUIREMENT	
3.5	Crimp tensile strenght	Subject terminal to direct pull at a rate of 25-50 mm/minute (The wire insulation must be cut to avoid the plastic material contribution to the wire crimp tensile).	WIRE SECTION (mm <sup>2</sup> )	MINIMUM TENSILE FORCE (N)
			0.3 ÷ 0.35	60
			0.5	80
			0.75 ÷ 0.80	95
			1.0	115
			1.5	150
			2.5	220
			4	300
			6	450
10	600			
3.6.1	Electrical overload resistance	Subject FASTON* Connector receptacle, mated with plain test tab , to a current 1.5 times the one specified at the point 3.2 for 1 hour.	No functioning breakdown or damage. Maximum mV drop must be the same as specified at the point 3.2.	
3.6.2	Temperature rise with current overloading, cyclic	Subject FASTON* Connector rec., mated with plain test tab , to a current 1.5 times the one specified at the point 3.2 for 500 cycles. Each cycle consists of : <ul style="list-style-type: none"> <li>• 45' under overload current</li> <li>• 15' at no load</li> </ul>	The temperature rise $\Delta t_1$ (the difference between the connection temperature and the ambient temperature) of any individual connection is measured after the 24 <sup>th</sup> cycle and the temperature rise $\Delta t_2$ after the 500 <sup>th</sup> cycle. The $\Delta t_2$ value shall not exceed by 15°C the $\Delta t_1$ value and neither rise shall exceed 85°C on transition between contact body and crimp wire barrel.	
3.6.3	Temperature rise with current overloading, cyclic. (for Steel Nickel plated versions, .250" sr. only)	Subject FASTON* Connector rec., mated with plain test tab , to a current of 16 A max. with wire 2.5 mm <sup>2</sup> & to a current of 10 A max. with wire 1.5 mm <sup>2</sup> , for 500 cycles. Each cycle consists of : <ul style="list-style-type: none"> <li>• 45' under overload current</li> <li>• 15' at no load</li> </ul>	The temperature rise of any individual termination shall not exceed 30°.	
3.7	Temperature cycling	Subject FASTON* Connector rec. mated with plain test tab to 5 cycles : Each cycle consists of : <ul style="list-style-type: none"> <li>• 2h : +100°C ± 2°C</li> <li>• 2h : + 40°C ± 2°C ( U.R. 90÷95% )</li> <li>• 2h : - 25°C ± 2°C</li> </ul>	Maximum mV drop can be the double of the one specified at the point 3.2	
3.8	Corrosion, salt spray	Subject FASTON* Connector rec., mated with plain test tab to 96 hours at 5% concentration of NaCl. (temperature : 35°C±2°C; PH : 6.5÷7.2)	Maximum mV drop can be the double of the one specified at the point 3.2	

3.9	Vibrations	Subject FASTON* Connector rec. mated with plain test tab, to 10±100±10 Hz at 10 g. acceleration; 2 hours in X and Y and Z directions - rate 1 octave/minute amplitude of oscillation 0.75 mm.	Maximum mV drop can be the double of the one specified at the point 3.2
-----	------------	---	---

**4. TEST SEQUENCE**

	TEST GROUP AND SEQUENCE						
	A	B	C	D	E	F	G
Appearance	1,7	1,3	1,4	1,3	1,4	1,4	1,4
Mating force (single contact)	2						
Unmating force (single contact)	4						
Durability	5						
Millivolt drop	3,6		3		3	3	3
Crimp tensile strength		2					
Temp. cycling			2				
Temp. rise with current overloading				2			
Corrosion, salt spray					2		
vibration						2	
Electrical overload resistance							2

**5. QUALIFICATION**

When all the tests have been successfully performed on the subject product line, the product is qualified according to the present specification.

**ARRANGEMENT FOR THE VOLTAGE DROP MEASUREMENT FOR RECEPTACLES**

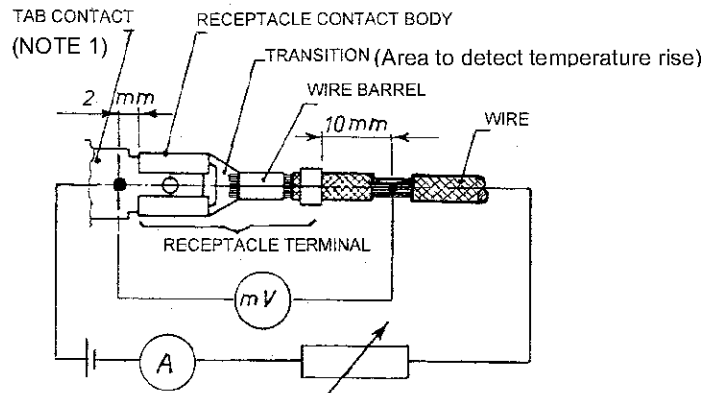

**NOTE:**

- 1) A male test tab having either a hole or dimple detent can be used (hole versions are preferred)
- 2) Design objective: First insertion 80N max., First extraction 40N min., 10<sup>th</sup> extraction 20N min.
- 3) Design objective: First insertion 50N max., First extraction 50N min., 10<sup>th</sup> extraction 25N min.

INVOLVED P/Ns (Base No. without prefix and suffix)

2.8 mm. (.110" Sr.)	4.8 mm. (& 5.0 mm) (.187" & .197" Sr.)	6.3 mm. (.250" Sr.)	9.5 mm. (.375" Sr.)
180420	100097	140760	160521
180423	100098	160301	160602
180436	160429	160389	160866
180437	160430	160608	280223
180457	160431	160807	281091
280006	160433	160808	
281470	160713	160854	
281624	160778	160855	
160196	282183 (5.0 mm)	160911	
160315	282332 (5.0 mm)	160912	
280429	281369 (5.0 mm)	160915	
		160916	
		180363	
		280000	
		280001	
		1-280001-1 (see Note 3 on page 4)	
		1-280001-2 (see Note 3 on page 4)	
		282172	
		282179	
		160256	
		160432	
		160465	
		280079	
		160739	
		1-280079-2 (see Note 2 on page 4)	