

CUSTOMER DRAWING

SPECIFICATIONS ARE SUBJECT TO CHANGE WITHOUT NOTICE

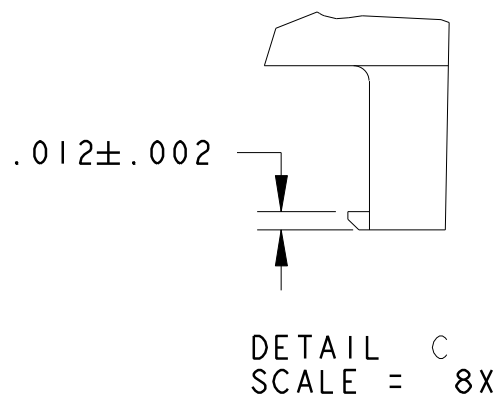
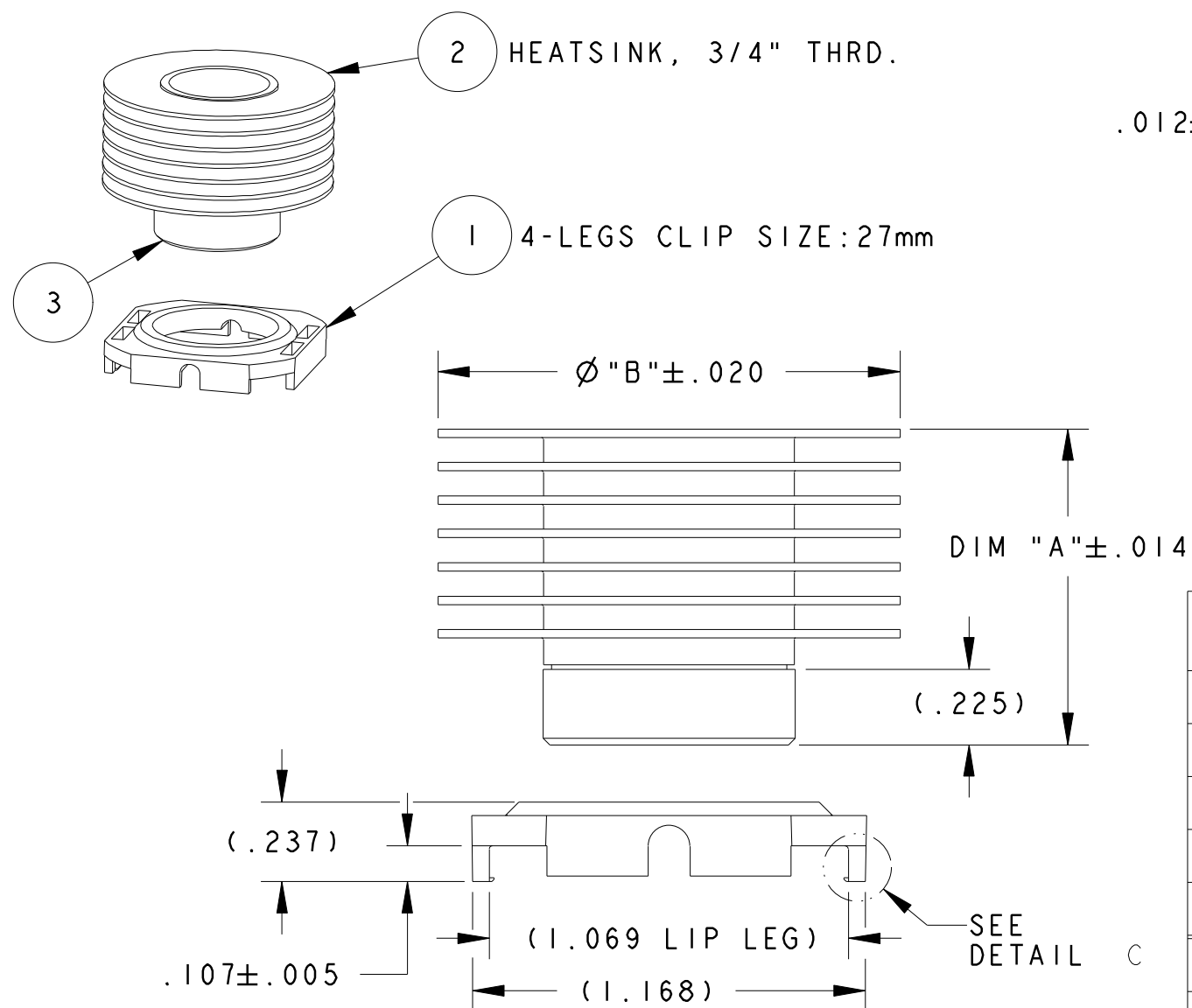

NOTES: UNLESS OTHERWISE SPECIFIED:

1. INTERPRET DRAWING PER ASME Y14.5M-1994.
2. MATERIAL: HEAT SINK: ALUMINUM
CLIP: BLACK PEI (UL94-V0)
3. BEFORE THE HEATSINK APPLICATION, THE USER SHOULD IDENTIFY THE SPECIFICATION OF MAXIMUM LOAD ON THE BGA PACKAGE.

SCREW DRIVER SLOT (.070 WIDE X .100 DEEP) PROVIDED IN THE CENTER PORTION OF THE HEAT SINK. FOR ACCURATE TORQUE SETTING, SCREW DRIVER BIT MUST BE ALIGNED TO THE CENTER LINE OF THE HEAT SINK.

HEATSINK TORQUE SPECIFICATIONS CONVERTED TO FORCE. BARE DIE PACKAGE:

- 1.5 POUND-FORCE INCH TORQUE = 7.5 POUND-FORCE (0.17 NEWTON METER TORQUE = 33.36 NEWTON)
- 2.0 POUND-FORCE INCH TORQUE = 10.0 POUND-FORCE (0.23 NEWTON METER TORQUE = 44.48 NEWTON)

FULL SIZE LID PACKAGE:

- 1.5 POUND-FORCE INCH TORQUE = 6.9 POUND-FORCE (0.17 NEWTON METER TORQUE = 30.69 NEWTON)
- 2.0 POUND-FORCE INCH TORQUE = 9.3 POUND-FORCE (0.23 NEWTON METER TORQUE = 41.37 NEWTON)

4. REMOVE CLIP WITH REMOVAL TOOL P/N: 1542616-1.
5. RoHS COMPLIANT AND CERTIFIED.

200 LFM	400 LFM	600 LFM				
3.63	2.30	1.89	2-1963554-7	Ø2.000" HS, 3/4" THRD. 7 FINS	2.000	.940
3.94	2.55	2.08	2-1963554-5	Ø2.000" HS, 3/4" THRD. 5 FINS	2.000	.740
4.29	2.76	2.22	2-1963554-4	Ø2.000" HS, 3/4" THRD. 4 FINS	2.000	.640
4.76	3.11	2.48	2-1963554-3	Ø2.000" HS, 3/4" THRD. 3 FINS	2.000	.540
5.23	3.46	2.75	2-1963554-2	Ø2.000" HS, 3/4" THRD. 2 FINS	2.000	.440
4.56	3.06	2.41	1-1963554-7	Ø1.375" HS, 3/4" THRD, 7 FINS	1.375	.940
4.95	3.29	2.61	1-1963554-5	Ø1.375" HS, 3/4" THRD, 5 FINS	1.375	.740
5.39	3.48	2.74	1-1963554-4	Ø1.375" HS, 3/4" THRD, 4 FINS	1.375	.640
5.97	3.95	3.09	1-1963554-3	Ø1.375" HS, 3/4" THRD, 3 FINS	1.375	.540
6.56	4.41	3.44	1-1963554-2	Ø1.375" HS, 3/4" THRD. 2 FINS	1.375	.440
Rca (°C/WATT)			ASSEMBLY HS PART NO.	DESCRIPTION	Ø "B"	DIM "A"
THERMAL PERFORMANCE			TABLE 2			

ITEM NO.	DESCRIPTION	QTY
3	INTERFACE	1
2	HEATSINK, 3/4" THRD.	1
1	MOUNTING CLIP	1

TABLE 1 (BOM)

REV.	DESCRIPTION	DATE
A	RELEASE	4-24-07
AI	RELEASED	5-24-07
B	RELEASED	10-18-07
BI	RELEASED	12-17-07

DO NOT SCALE			North Attleboro, Massachusetts 02760		CONFIDENTIAL PROPERTY OF TYCO ELECTRONICS. NOT TO BE DISCLOSED TO OTHERS. REPRODUCED OR USED FOR ANY PURPOSES EXCEPT AS AUTHORIZED IN WRITING BY AN AUTHORIZED OFFICIAL OF TYCO ELECTRONICS. MUST BE RETURNED TO TYCO ELECTRONICS ON DEMAND, ON COMPLETION OF ORDER OR OTHER PURPOSES FOR WHICH SENT.	TITLE: ASSEMBLY HEATSINK WITH 4 LEGS, 27mm CLIP			
	UNLESS OTHERWISE SPECIFIED TOLERANCES ARE:		DRAWN BY: E. TAO	DATE: 4-24-07		MATERIAL: N/A	DIMENSIONS ARE IN: INCHES	SCALE: 2:1	TE PART NO.: SEE TABLE 2
	.XX ± . .XXX ± . .XXXX ± . ANGLES ± °		ENGINEER: V. KHEIL	DATE: 4-30-07			FINISH: N/A	SIZE: B	SHEET 1 of 1
			FILENAME: C-1963554	PROJECT: PRO-E		THIRD ANGLE PROJECTION		DWG. NO.: C-1963554	REV. BI

Mouser Electronics

Authorized Distributor

Click to View Pricing, Inventory, Delivery & Lifecycle Information:

[TE Connectivity:](#)

[1-1963554-4](#)