

ITEM NUMBER	TE PART NUMBER	DESCRIPTION	QTY PER ASSY
1	1055441-1	INSERTS	1
2	1055440-1	INSERTS	1
3	1055450-1	DIELECTRIC RECESS TOOL	1
4	1055448-1	DIELECTRIC INSERT TOOL	1
5	1055442-1	LOCATOR TOOL	1
6	1055443-1	LOCATOR TOOL	1
7	1055447-1	DIELECTRIC INSERT TOOL	1
8	91362-1	SOLDER GAGE	1
9	91362-2	SOLDER GAGE	1
10	91362-6	SOLDER GAGE	1
11	1055454-1	CENTER CONTACT HOLDER	1
12	2217686-1	CASE, PLASTIC, SMA TOOL	1
13	1055449-1	LOCKING RING PLIERS	1
14	1055446-1	LOCATOR TOOL	1
15	1055451-1	LOCATOR TOOL	1
16	1055439-1	CABLE, FIXTURE	1

Figure 1

1. INTRODUCTION

Solder Assembly Kit 1055420-1 for SMA (OSM) Connectors, shown in Figure 1, contains everything necessary to solder SMA solder style connectors to 2.16 mm [.085 in.] and 3.58 mm [.141 in.] diameter semi-rigid and flexible cable.



NOTE

Tool directions in this document are for reference only. Refer to the appropriate connector assembly instructions to ensure proper assembly. Refer to Figure 2 for connector assemblies and their associated instruction sheets.

SEMI-RIGID CABLE CONNECTORS			FLEXIBLE CABLE CONNECTORS		
CONNECTOR PART NUMBER		INSTRUCTION SHEET	CONNECTOR PART NUMBER		INSTRUCTION SHEET
1050757-1 1050541-1 1050542-1	1044072-1 1056390-1 1050756-1	408-4761	1051644-1	1051643-1	408-4756
1044533-1 1222331-1	1050524-1 1050525-1	408-4764	1052066-1 1062178-1	1052067-1	408-4815
1050769-1 1091921-1	1050770-1	408-4765	1052062-1	1052063-1	408-4816
1050854-1 1051052-1	1051081-1	408-4767	1051942-1	---	408-4817
1055574-1 1087192-1 1311056-1	1051013-1 1314254-1	408-4768	1051861-1 1052022-1	1051862-1	408-4810
1051151-1 1051157-1 1088312-1	1051156-1 1082030-1 1313559-1	408-4831	1051852-1	---	408-4820
1051085-1 1051046-1 1087300-1	1051049-1 1050859-1	408-4833	1051638-1	1051639-1	408-4821

Figure 2



NOTE

Contact customer service or refer to Catalog 1307191 for additional information.



NOTE

Dimensions are in metric units [with U.S. customary units in brackets], unless otherwise indicated. Figures and illustrations are for reference only and are not drawn to scale.

2. DESCRIPTION

Solder Assembly Kit 1055420-1 contains the tooling required to properly solder SMA connectors to semi-rigid and flexible coax cable. The kit contains a cable fixture sub-assembly, two sets of clamp inserts for 2.16 mm [.085 in.] and 3.58 mm [.141 in.] cable, and four types of locators that are used to properly align the connector and cable. The kit also contains three solder gages for proper spacing of the center contact, a center contact holder, three dielectric insertion/recess tools, and locking ring pliers.

The cable fixture subassembly consists of a fixture frame, thumbscrew, positioning tool and spring. See Figure 3. When used with the proper clamp inserts the assembly holds and locates coaxial cable for soldering.

3. INSTALLING/REPLACING THE CLAMP INSERT



NOTE

Clamp inserts come in sets of two. Upper and lower inserts are interchangeable.

1. Select the appropriate clamp inserts. Refer to Figure 1 for the appropriate clamp inserts.
2. Remove the cable fixture thumbscrew by rotating it in a counterclockwise direction.
3. Remove the positioning tool by rotating it in a counterclockwise direction.
4. Remove the clamp inserts from the frame after the positioning tool is removed.
5. Sandwich the spring in the pockets on the replacement clamp inserts.
6. Place clamp inserts in the fixture frame and reinstall the positioning tool.
7. Retighten positioning tool.
8. Reinstall the thumbscrew.

4. TRIMMING CABLE WITH FIXTURE FRAME

The fixture frame is equipped with six trimming holes designed to remove the outer jacket and cable dielectric. The side marked with the number 2 is for trimming 1.78 mm [.070 in.], 2.16 mm [.085 in.], and 3.58 mm [.141 in.] cable. See Figures 3 and 4. When cable is fully bottomed during trimming, a strip length of 2.79 mm [.110 in.] will result. If different strip lengths are required the center conductor must be trimmed separately.

The side marked with a number the number "1" is for trimming cable already mounted in a connector housing. See the connector specific instruction sheet for more information.



NOTE

Trim blades are NOT included with the kit. Use a razor blade with 0.38 mm [.015 in.] maximum thickness.

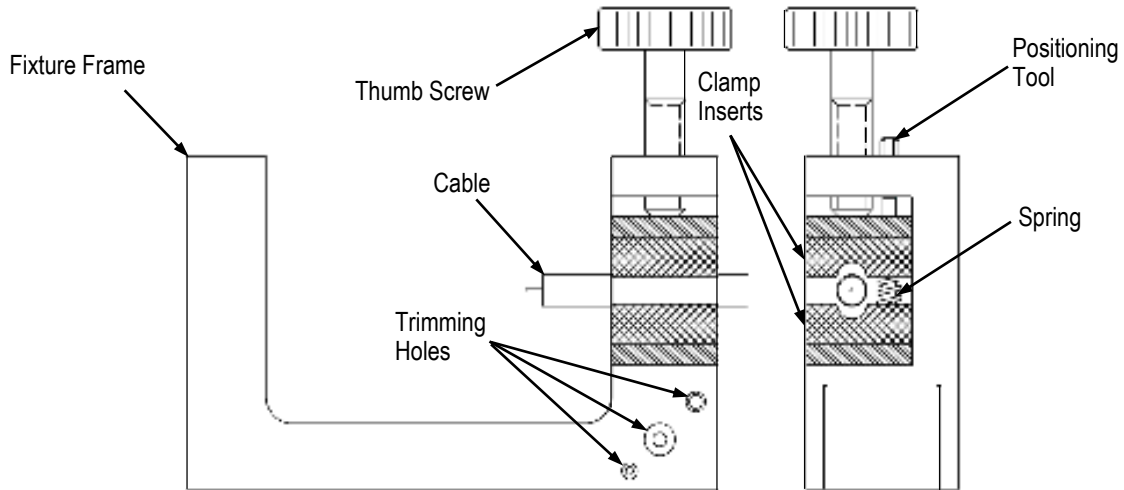

Figure 3

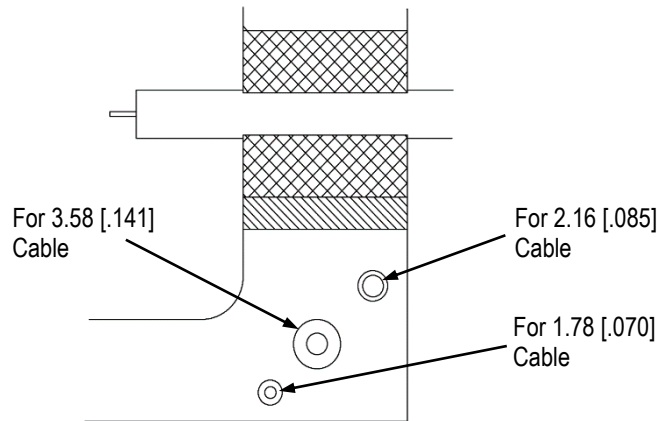

Figure 4

5. USING SOLDER GAGES AND CENTER CONTACT HOLDER

The center contact holder is designed to hold both male and female center contacts for SMA connectors.

Solder gages are used to properly space the center contact away from the cable dielectric. Refer to the connector specific instruction sheet for the appropriate solder gage to be used during the assembly procedure.



CAUTION

Center contact holders contains small amounts of lead. The lead is used for assembly.

**NOTE**

Maximum operating temperature for the center contact holder is 300°C [572°F].

**DANGER**

To avoid personal injury, be sure to observe all local safety practices (including the use of gloves). The solder gage, center contact holder, and the contact may be hot after soldering.

6. USING LOCATING TOOLS

Solder Assembly Kit 1055420-1 contains four locating tools. Refer to the connector specific instruction sheet for selection of proper locator tool and assembly instructions.

Type A, as well as Type B locating tools are available.

6.1. Using Type A Locating Tools

The solder assembly kit contains two Type A locator tools. These tools are designed to be used with the fixture subassembly. To ensure proper connector assembly, follow the instructions listed below.

1. Place connector housing on end of cable sub-assembly. The subassembly refers to cable with center contact.
2. Place loose connector assembly in fixture base.
3. Nest the center contact in locator tool.
4. Tighten the thumbscrew to secure the cable.
5. Tighten the locator tool to seat the cable firmly.
6. Slide connector housing over locator tool.
7. Maintain position of housing firmly against locator tool.

**DANGER**

To avoid personal injury, be sure to follow all local safety practices when using solder and solder equipment.

8. Solder according to the connector specific instructions.

**NOTE**

Fixture should be clamped vertically in vise to keep housing seated against locator tool.

6.2. Using Type B Locating Tools

The solder assembly kit contains two Type B locator tools. These tools are used to confine the connector dielectric, which aids in providing proper cable seating when soldering to flexible cable. To ensure proper connector assembly, follow connector specific instructions.

7. USING DIELECTRIC TOOLS

Solder Assembly Kit 1055420-1 contains three dielectric tools. Two dielectric (insertion) tools are used to insert the dielectric bushing into the connector housing. The dielectric (recess) tool is used to compress expanded cable dielectric after soldering semi-rigid coaxial cable to the connector housing, if required.

Use the following instruction to press the dielectric bushing into the connector subassembly.

1. Thread the insertion tool into connector subassembly.
2. Insert the dielectric into insertion tool housing.
3. Place insertion tool plunger into position.
4. Press the plunger until the flange bottoms on the tool housing.

8. USING LOCKING RING PLIERS

The locking ring pliers are used to compress the retaining ring, allowing installation of the coupling nut on specific connectors. Use the pliers as follows:

1. Place retaining ring (and gasket) on connector housing.
2. Compress the retaining ring with the retaining ring pliers.
3. Push coupling nut on to housing and over the retaining ring.
4. Check to make sure the coupling nut rotates freely after the retaining ring is in place.

9. REVISION SUMMARY

- Updated document to corporate requirements
- Changed artwork and parts list in Figure 1.