

LOC	DIST	REVISIONS					
		P	LTN	DESCRIPTION	DATE	DWN	APVD
GP	00	G1		REVISED PER ECO-11-016901	05APR2012	KH	AS
		G2		ADD MODULE EXTRACTION GUIDE	10JUL2012	AY	SZ

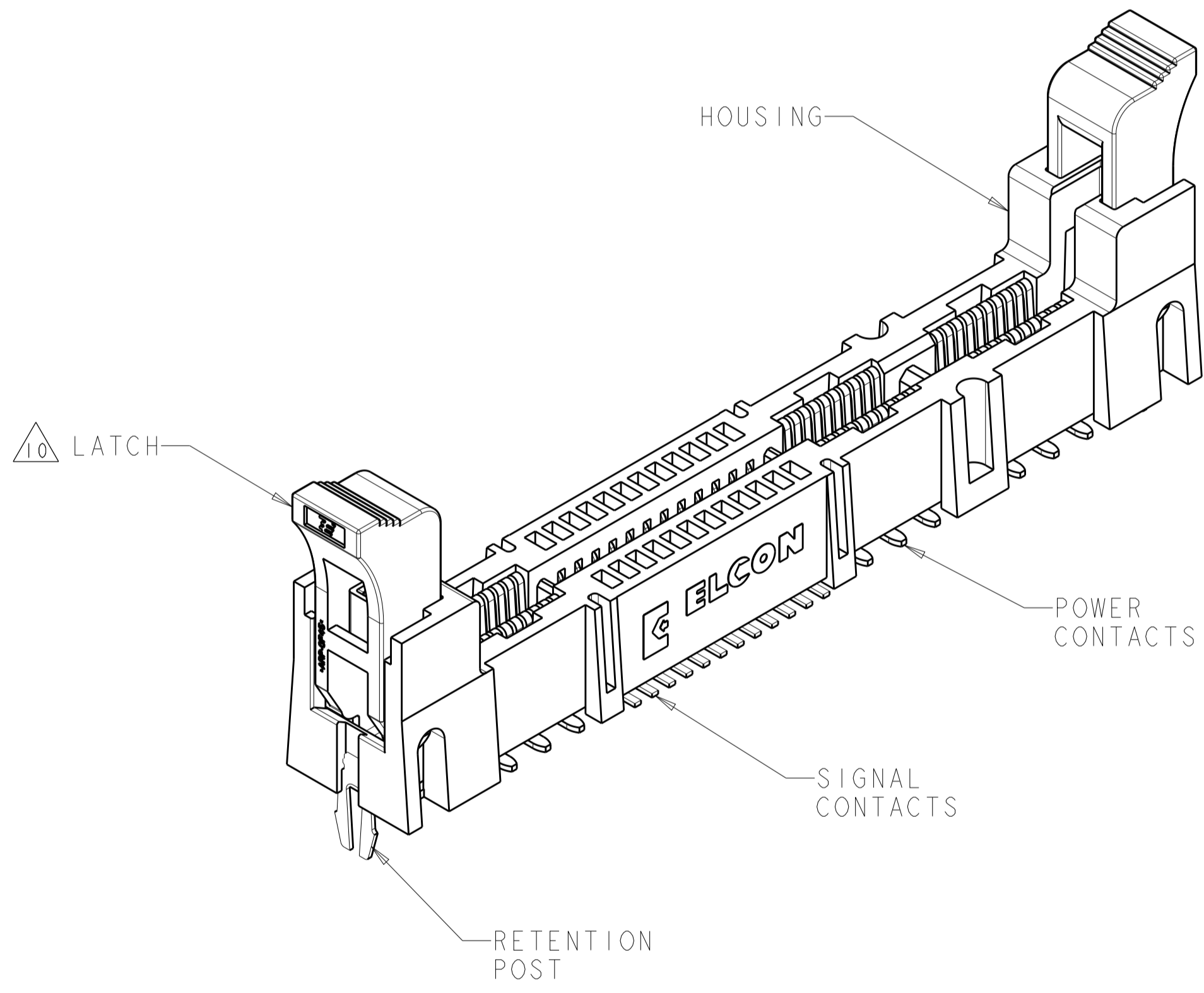

1. PART NUMBER CHANGES AND OR DESIGN CHANGES AFFECTING ITEM INTERCHANGEABILITY REQUIRE PRIOR TYCO ELECTRONICS APPROVAL AND AUTHORIZATION BY REVISION TO THIS DRAWING.
2. MATERIAL:
 HOUSING: GLASS FILLED POLYESTER, COLOR-BLACK
 UL94V-0 FLAMMABILITY RATED
 LATCHES: THERMOPLASTIC, GLASS REINFORCED,
 COLOR: BLACK, UL94V-0 FLAMMABILITY RATED
 CONTACTS: COPPER ALLOY
 RETENTION POST: COPPER ALLOY
3. FINISH:
 SIGNAL CONTACTS:
 MATING AREA-0.76µm MIN GOLD OVER 3.81µm MIN NICKEL
 0.64µm MIN NICKEL PLATE OVER REMAINDER
 SMT TAILS-3.81µm MIN MATTE TIN OVER NICKEL PLATE
 POWER CONTACTS:
 1.27µm MIN NICKEL PLATE ALL OVER
 MATING AREA-0.76µm MIN GOLD OVER NICKEL PLATE
 SMT TAILS-3.05µm MIN TIN OVER NICKEL PLATE
 RETENTION POSTS:
 3.05µm MIN MATTE TIN OVER 0.63µm MIN NICKEL
4. ITEMS PROVIDED TO THIS SPECIFICATION TO BE PERMANENTLY IDENTIFIED WITH PART NUMBER AND DATE CODE.
5. MAXIMUM BURR OF 0.013 ON CARD TAB AREA.
6. SET TRACE BACK FROM PC BOARD EDGE. NO SOLDERMASK ALLOWED BETWEEN PC BOARD EDGE AND TRACE.
7. CONNECTOR ACCEPTS 1.57±0.13 THICK PC BOARD.
8. KEEP OUT AREA FOR COMPONENTS ONLY.
9. FEATURE REQUIRED FOR USE WITH EJECTOR.
10. CAUTION:
 LATCHES ARE INTENDED FOR RETENTION OF PC BOARD TO CONNECTOR. DO NOT ATTEMPT TO FULLY EJECT PC BOARD FROM CONNECTOR WHILE DISENGAGING LATCHES, DAMAGE TO LATCHES AND OR CONNECTOR MAY OCCUR.
11. RECOMMENDED GOLD FINGER LENGTH FOR RELIABLE CONTACT.
12. DATUMS AND BASIC DIMENSIONS ESTABLISHED BY CUSTOMER.
13. FOR DESIGN OBJECTIVES SEE 108-2301.

4.61	1926155-4
4.19	1926155-3
3.68	1926155-2
DIM "A"	PART NUMBER

THIS DRAWING IS A CONTROLLED DOCUMENT.		DWN G. PETERS/DTI	25MAY2006	TE Connectivity NAME SOCKET CONNECTOR WITH LATCH, SMT P2-S24-P4 MINI CROWN EDGE
DIMENSIONS: mm		CHK N. REESER	25MAY2006	
TOLERANCES UNLESS OTHERWISE SPECIFIED:		APVD N. REESER	25MAY2006	PRODUCT SPEC
0 PLC ±.5 1 PLC ±.5 2 PLC ±.25 3 PLC ±.5 4 PLC ±.5 ANGLES ±.2		APPLICATION SPEC		SIZE CAGE CODE DRAWING NO
MATERIAL		FINISH		RESTRICTED TO
CUSTOMER DRAWING		WEIGHT		A100779C=1926155
SCALE 1:1		SHEET 1 OF 5		REV G2

LOC	DIST	REVISIONS					
GP	00	P.	LYR	DESCRIPTION	DATE	DWN	APVD
		-		SEE SHEET 1	-	-	-

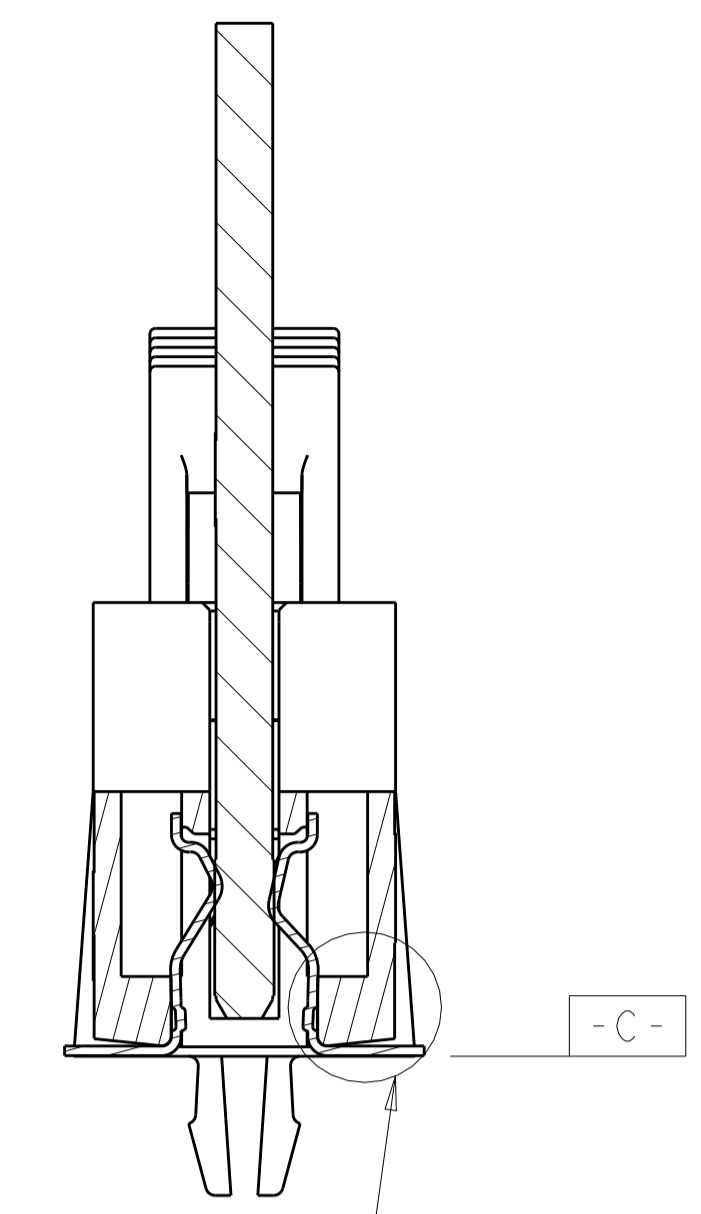
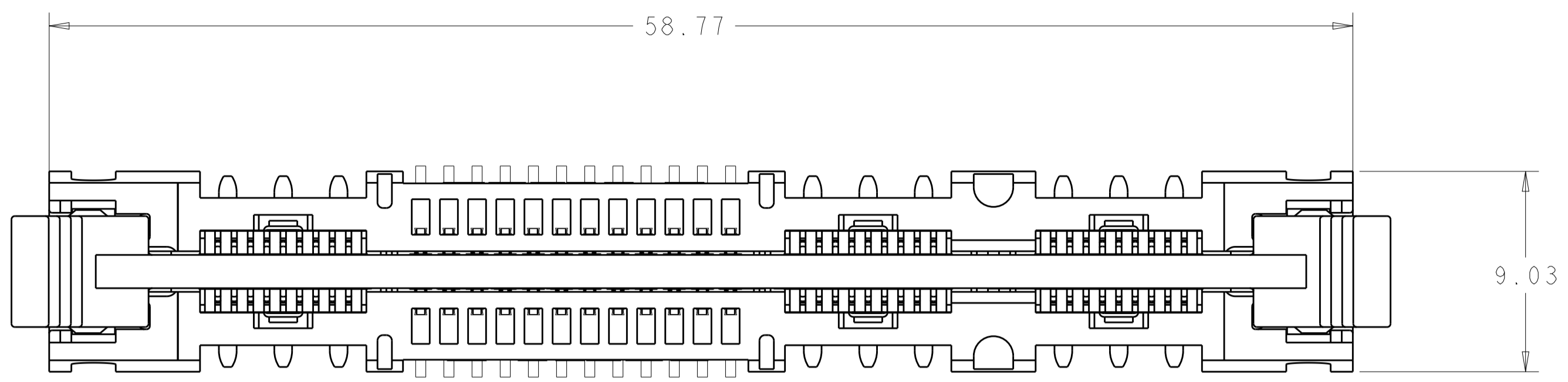

SECTION R-R
SEE DETAIL H

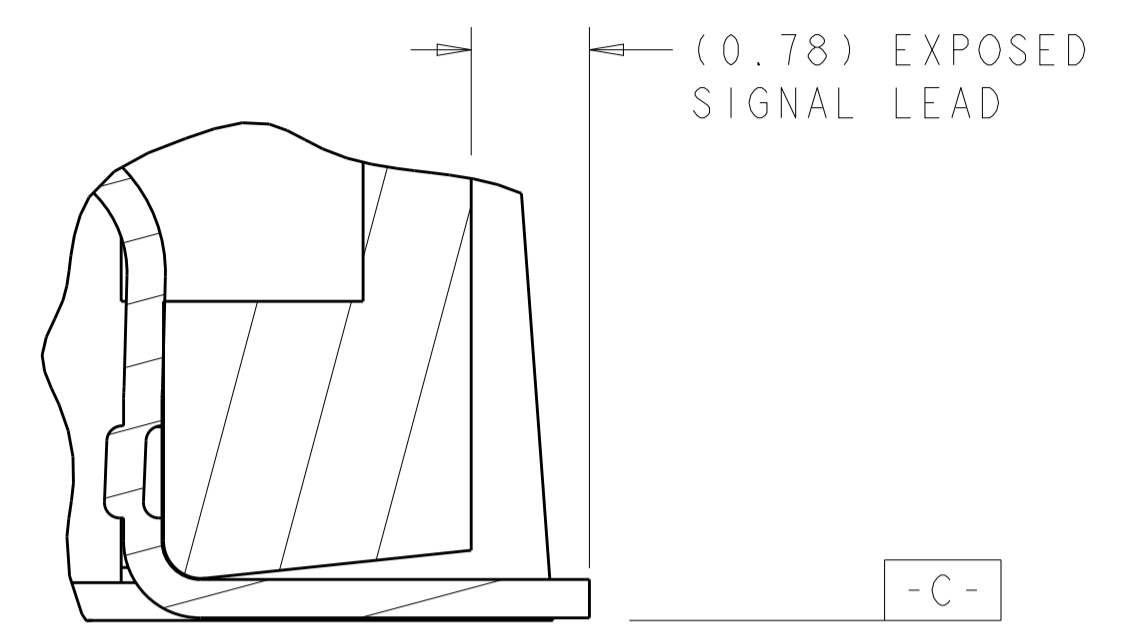

DETAIL H
SCALE 20:1

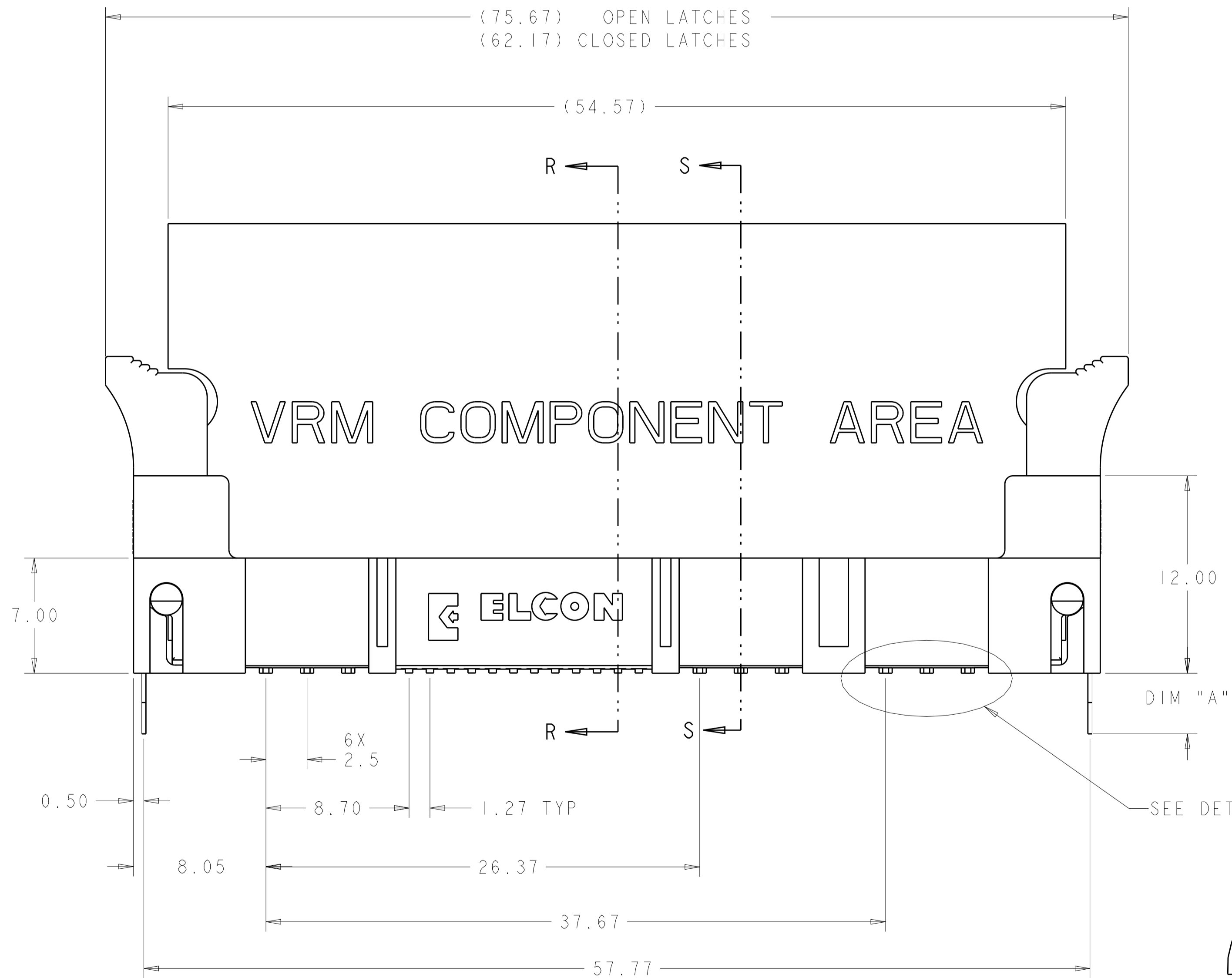

SEE DETAIL Z

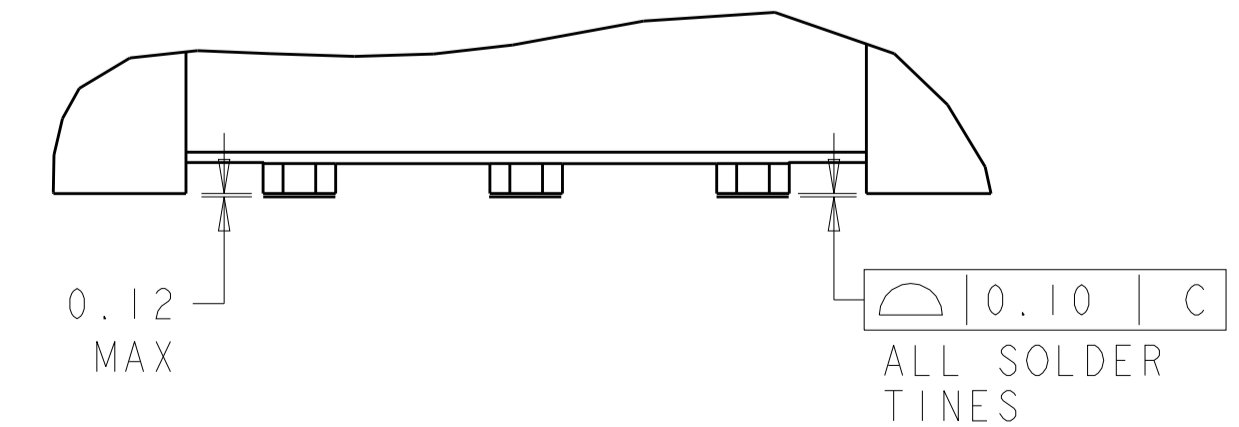

DETAIL Z
SCALE 12:1

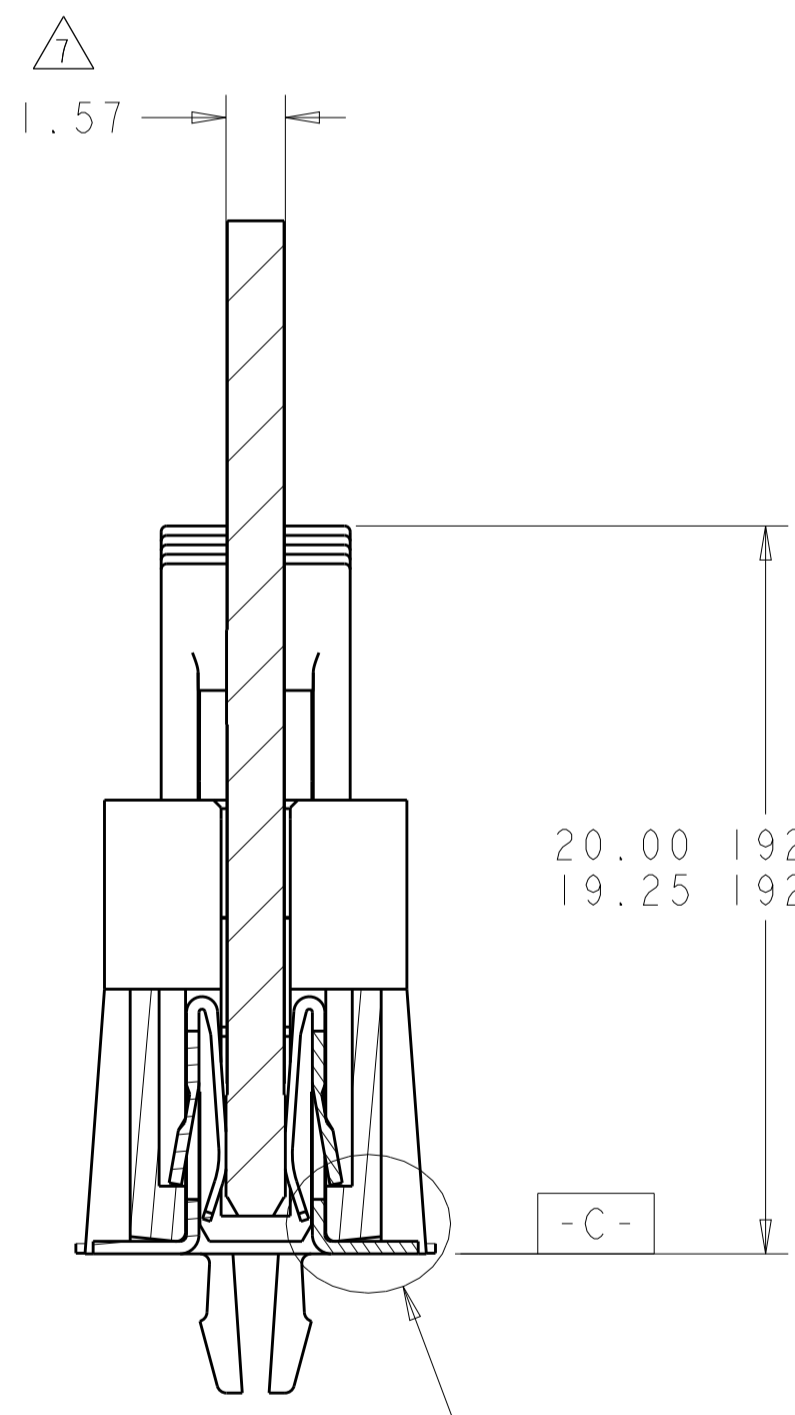

SECTION S-S

20.00 1926155-1
19.25 1926155-2

SEE DETAIL G

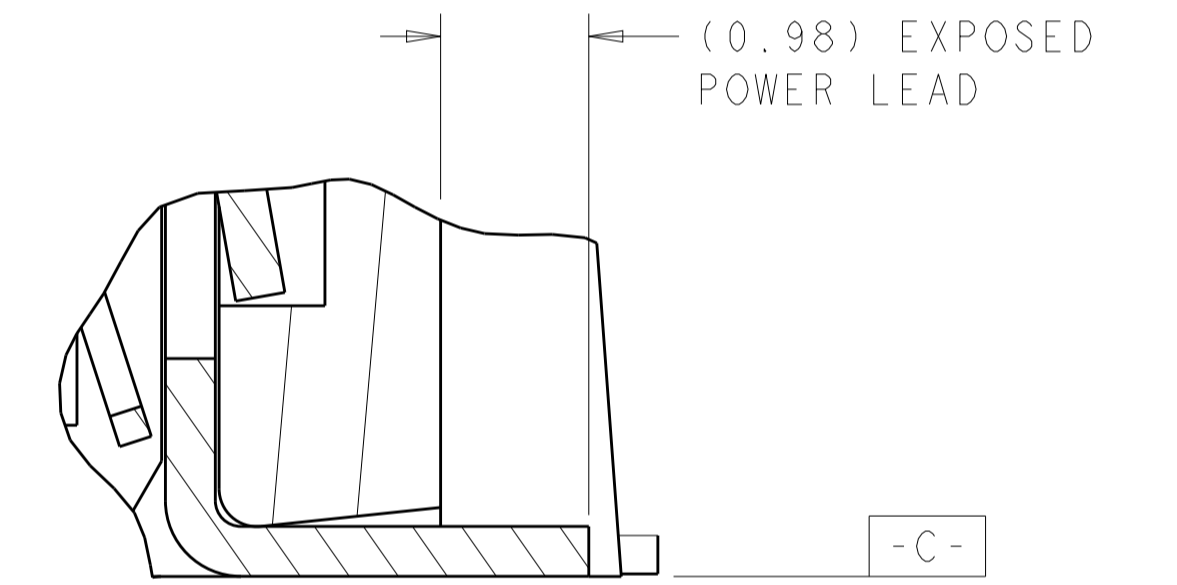

DETAIL G
SCALE 20:1

THIS DRAWING IS A CONTROLLED DOCUMENT.		DWN: G. PETERS/DTI 25MAY2006	TE Connectivity NAME: SOCKET CONNECTOR WITH LATCH, SMT P2-S24-P4 MINI CROWN EDGE
DIMENSIONS: mm		CHK: N. BEESER 25MAY2006	
TOLERANCES UNLESS OTHERWISE SPECIFIED:		APVD: N. BEESER 25MAY2006	PRODUCT SPEC
0 PLC	±.5	APPLICATION SPEC	SIZE: CAGE CODE: DRAWING NO: A100779C=1926155
1 PLC	±.5	RESTRICTED TO	SCALE: 5:1 SHEET 2 OF 5 REV: G2
2 PLC	±.25		
3 PLC	±.25		
4 PLC	±.25		
ANGLES	±.2		
MATERIAL		WEIGHT	
FINISH		CUSTOMER DRAWING	

LOC	DIST	REV	DATE	BY	APPV
GP	00				
REVISIONS			DESCRIPTION	DATE	DWN
			SEE SHEET 1		

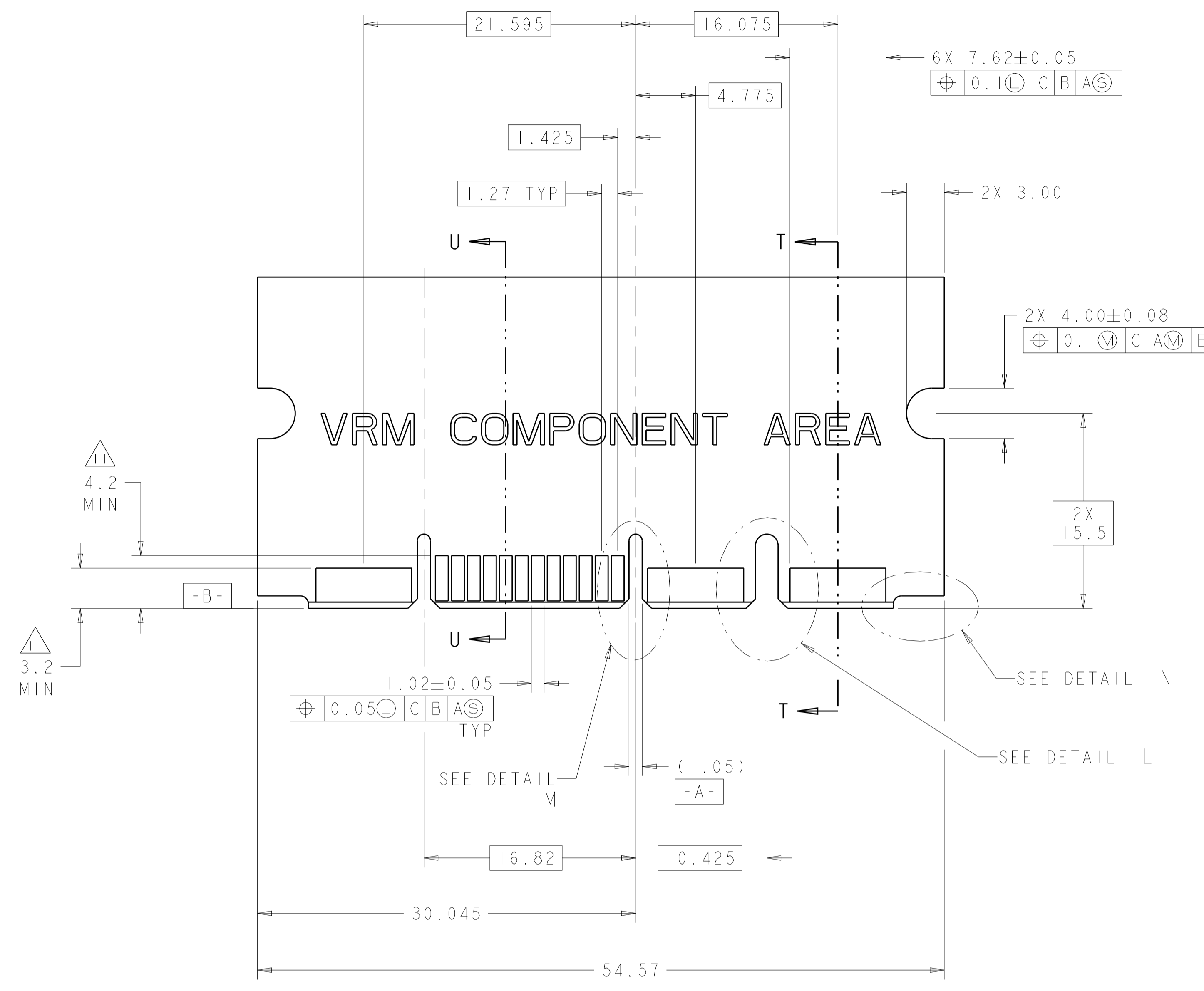

RECOMMENDED MATING BOARD
SCALE 4:1

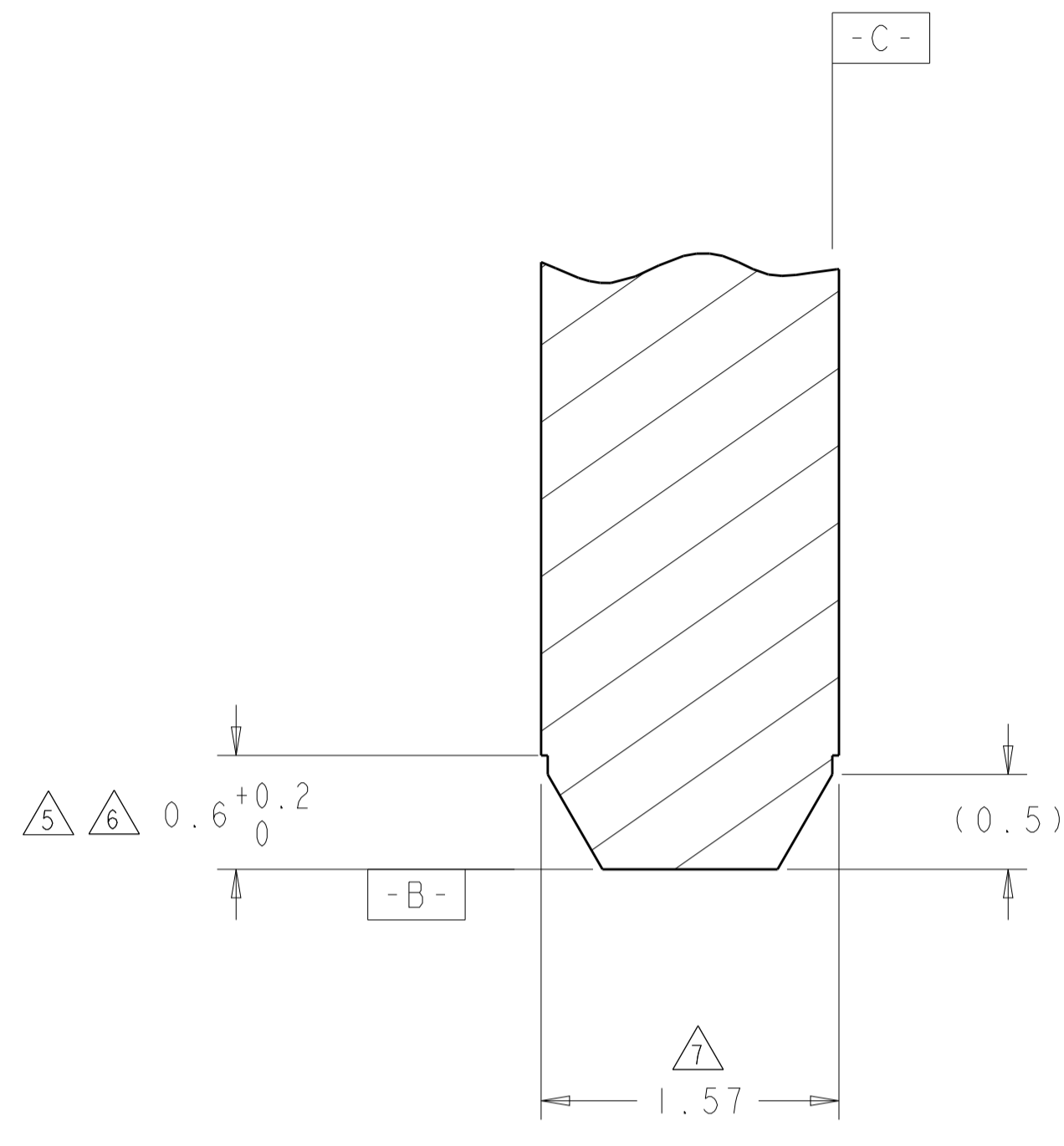

SECTION U-U
SCALE 30:1

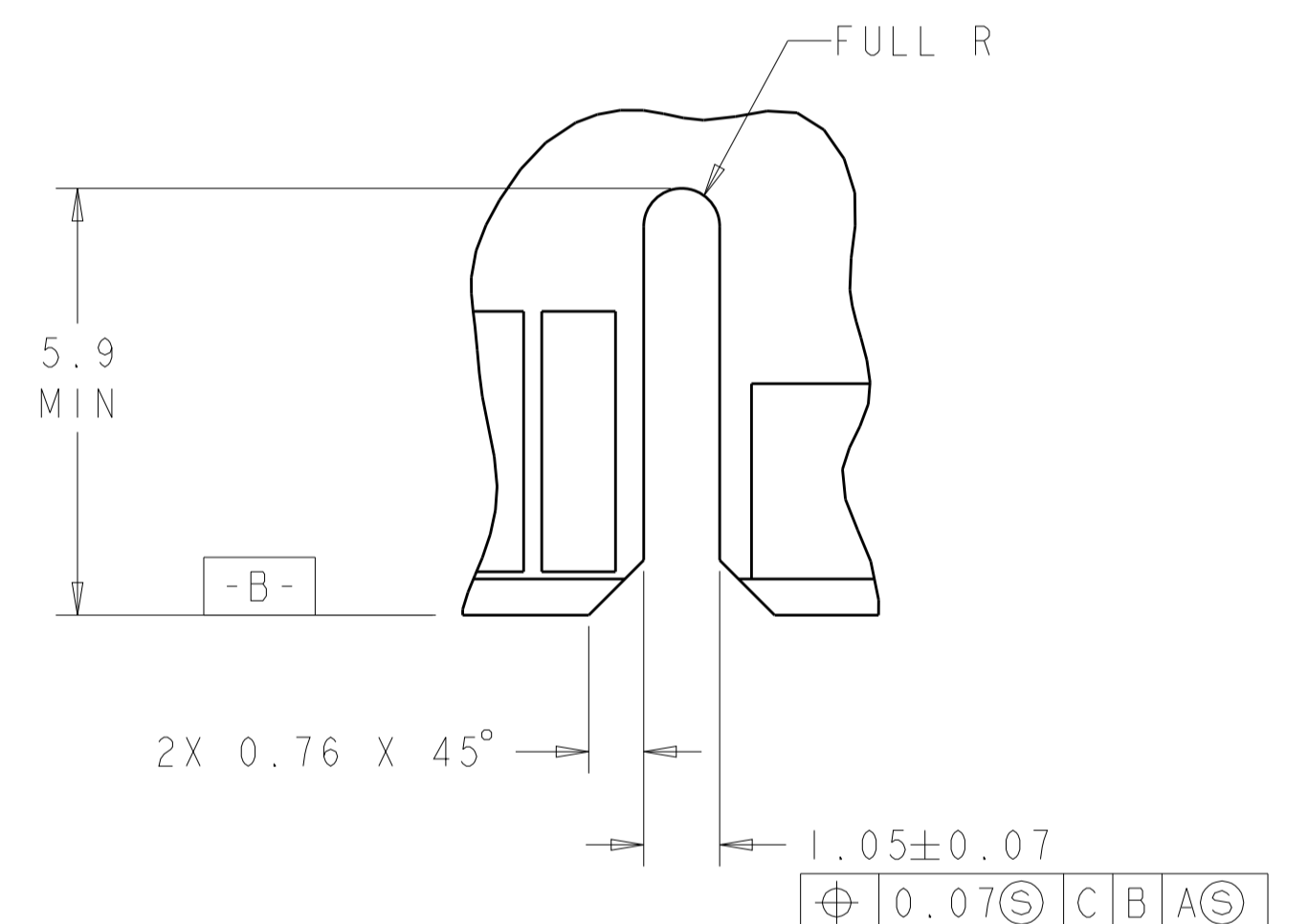
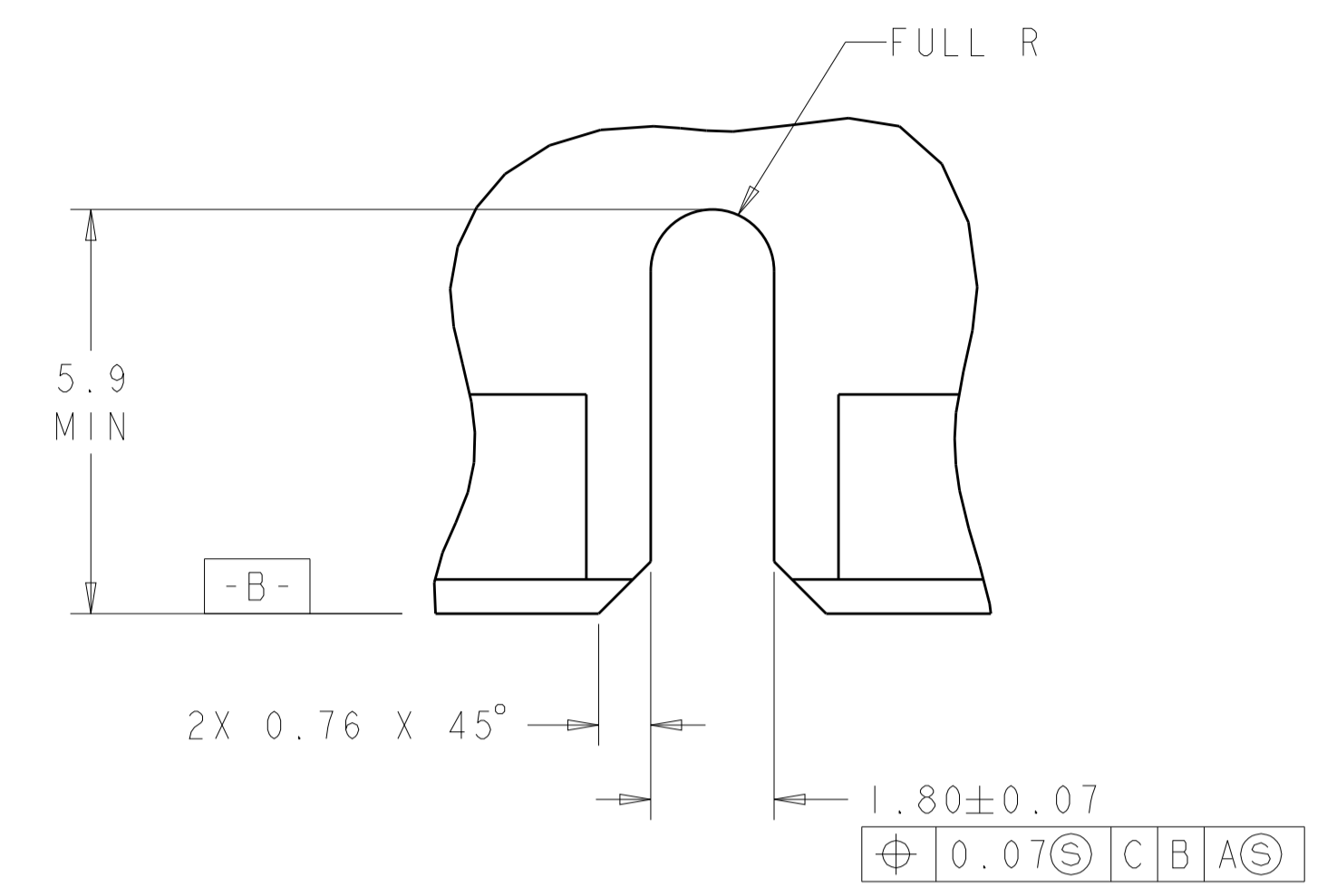

DETAIL M
2X TYPICAL
SCALE 10:1

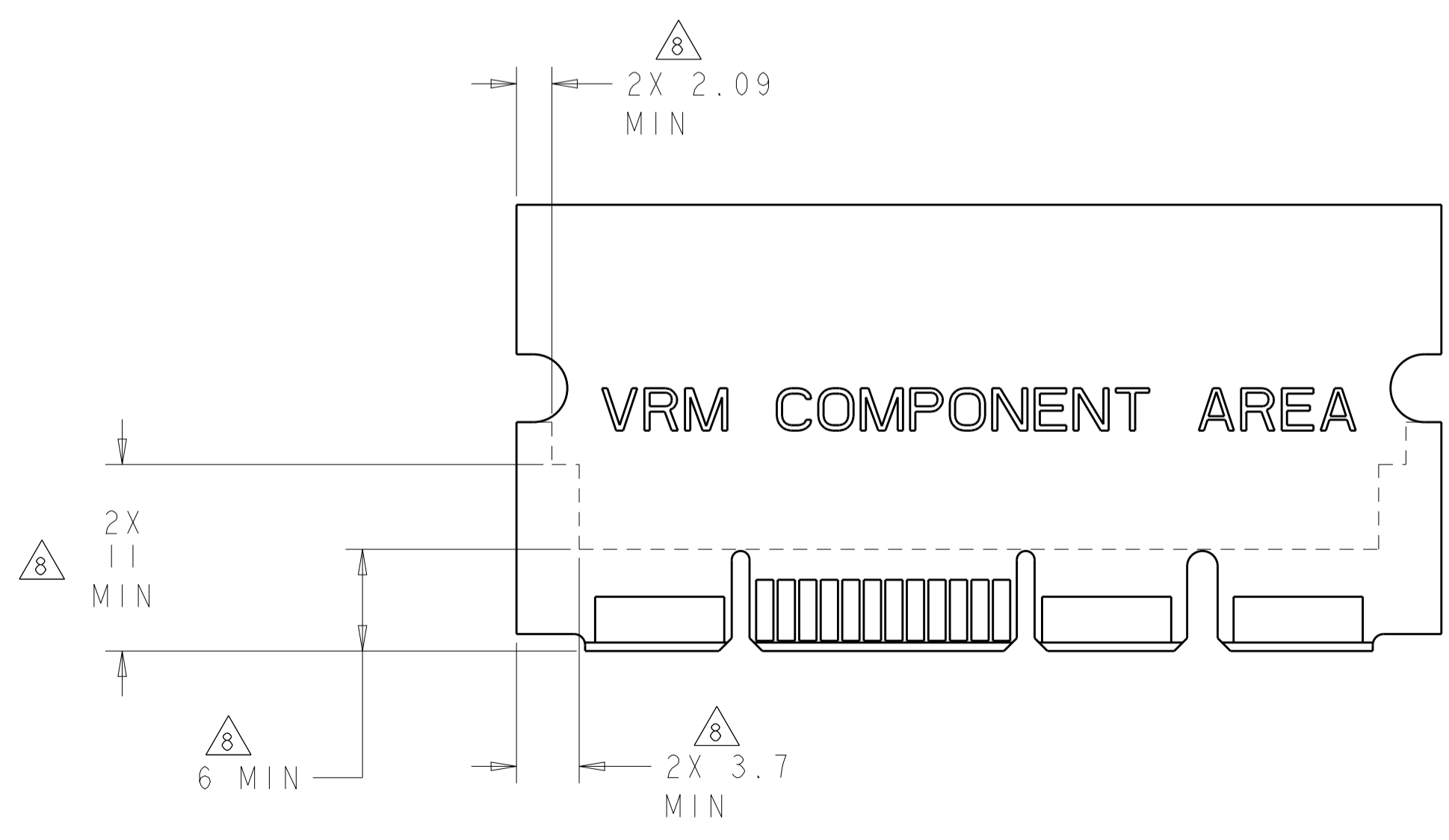

RECOMMENDED PC BOARD KEEP OUT AREA
SCALE 3:1

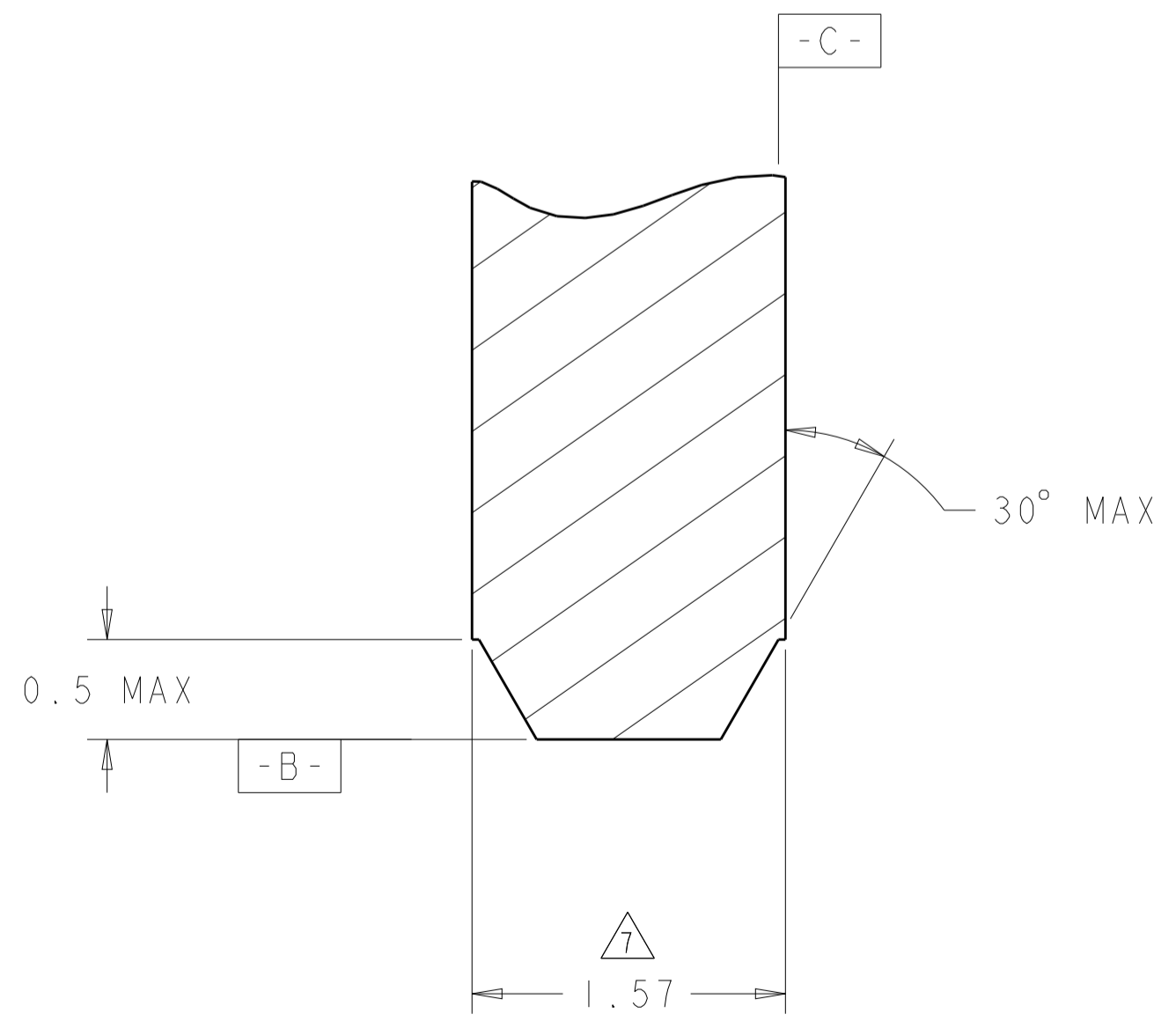

SECTION T-T
SCALE 30:1

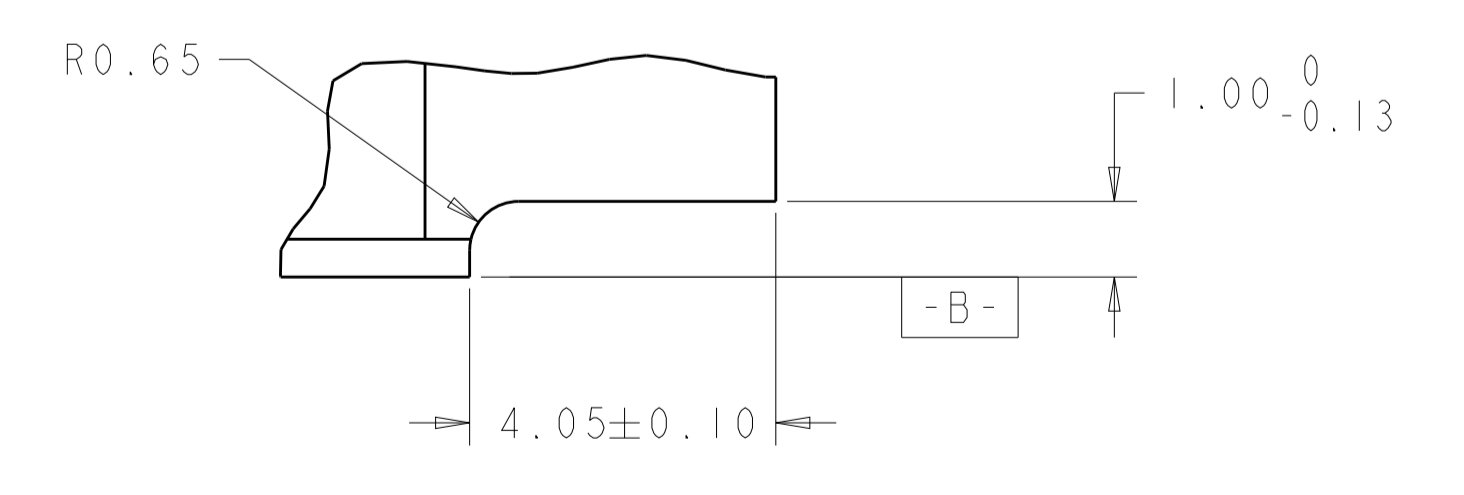

DETAIL N
2X TYPICAL
SCALE 10:1

THIS DRAWING IS A CONTROLLED DOCUMENT.		DWN: G. PETERS/DTI	25MAY2006	STE TE Connectivity
DIMENSIONS: mm		CHK: N. REESER	25MAY2006	
TOLERANCES UNLESS OTHERWISE SPECIFIED:		APVD: N. REESER	25MAY2006	NAME: SOCKET CONNECTOR WITH LATCH, SMT P2-S24-P4 MINI CROWN EDGE
0 PLC ±.5		PRODUCT SPEC		
1 PLC ±.5		APPLICATION SPEC		SIZE: CAGE CODE: DRAWING NO: A100779C=1926155
2 PLC ±.25		RESTRICTED TO		
3 PLC ±.25		SCALE: 5:1	SHEET 3 OF 5	REV: G2
4 PLC ±.25		CUSTOMER DRAWING		
ANGLES ±.2				
FINISH				

LOC	DIST	REVISIONS					
GP	00	P	LTN	DESCRIPTION	DATE	DWN	APVD
		-		SEE SHEET 1			

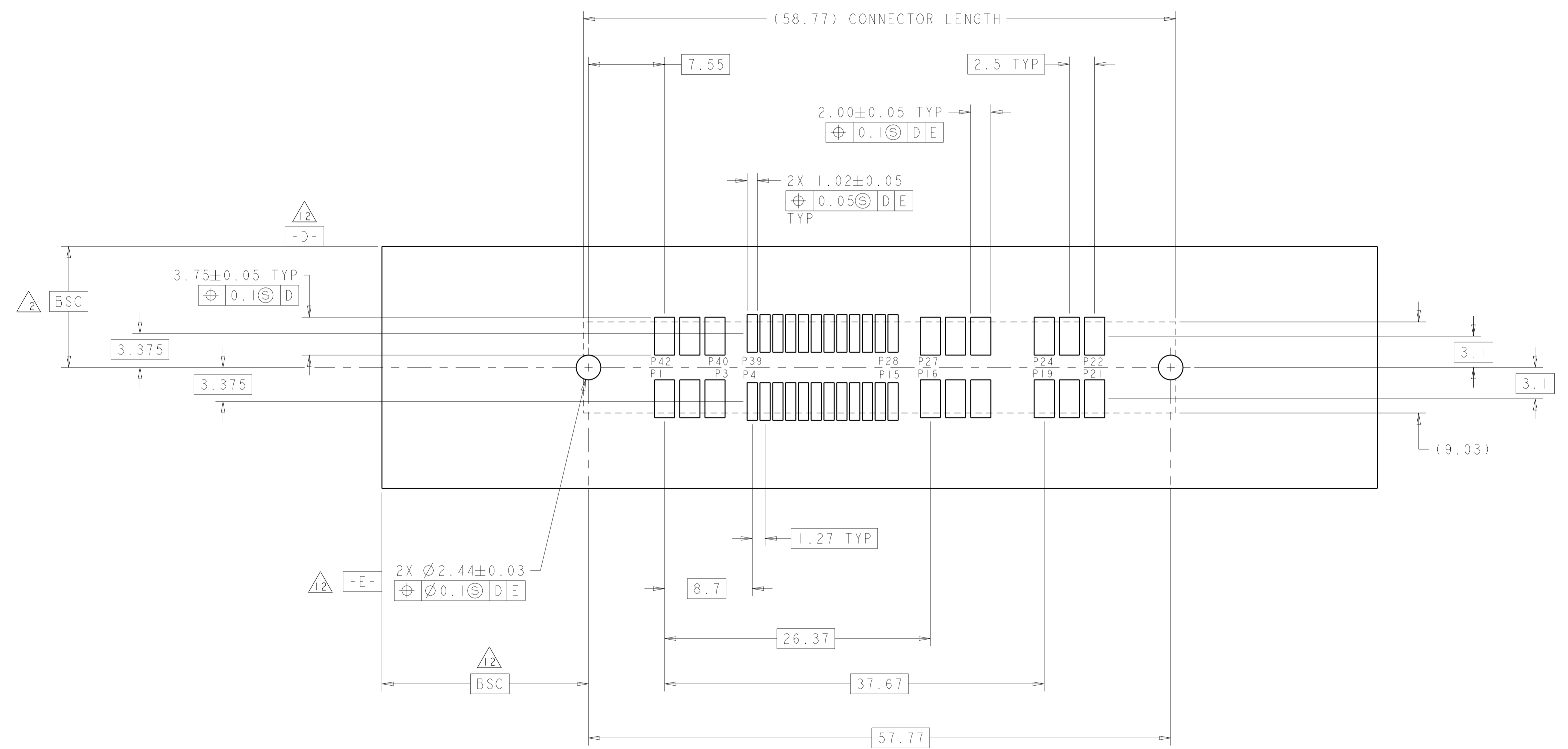

RECOMMENDED SOLDER LAND GUIDELINE
 AS VIEWED FROM CONNECTOR SIDE
 SCALE 4:1

THIS DRAWING IS A CONTROLLED DOCUMENT.		DWN G. PETERS/DTI 25MAY2006	TE Connectivity
DIMENSIONS: mm		CHK -	
TOLERANCES UNLESS OTHERWISE SPECIFIED:		APVD W. REESER 25MAY2006	NAME SOCKET CONNECTOR WITH LATCH, SMT P2-S24-P4 MINI CROWN EDGE
0 PLC ±.5 1 PLC ±.5 2 PLC ±.25 3 PLC ±. 4 PLC ±. ANGLES ±.2		PRODUCT SPEC	
MATERIAL		APPLICATION SPEC	RESTRICTED TO
FINISH		WEIGHT	SIZE CAGE CODE DRAWING NO
CUSTOMER DRAWING		SCALE 5:1	A100779C=1926155
		SHEET 4 OF 5	REV G2

LOC	DIST	REVISIONS					
GP	00	P	LTN	DESCRIPTION	DATE	DWN	APVD
		-		SEE SHEET 1		-	-

MODULE EXTRACTION GUIDE

STEP 1

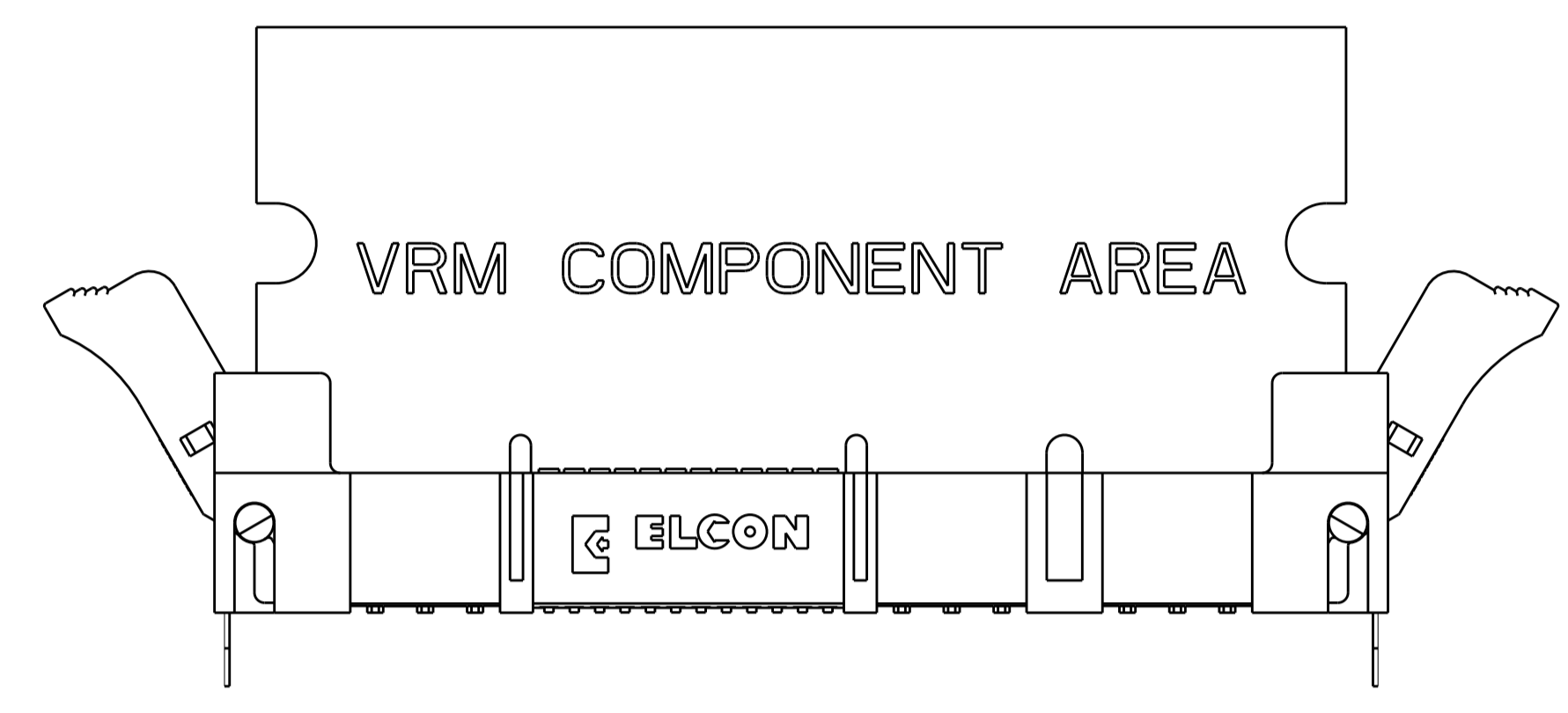

THE MODULE IS REMOVED FROM THE SOCKET FIRST BY SIMULTANEOUSLY ROTATING EACH LATCH APPROXIMATELY 30 DEGREES AWAY FROM THE HOUSING END. AT FULL ROTATION OF THE LATCH, THE MODULE IS NOT COMPLETELY DISLODGED. THE MODULE WILL STILL BE APPROXIMATELY 15% ENGAGED.

STEP 2

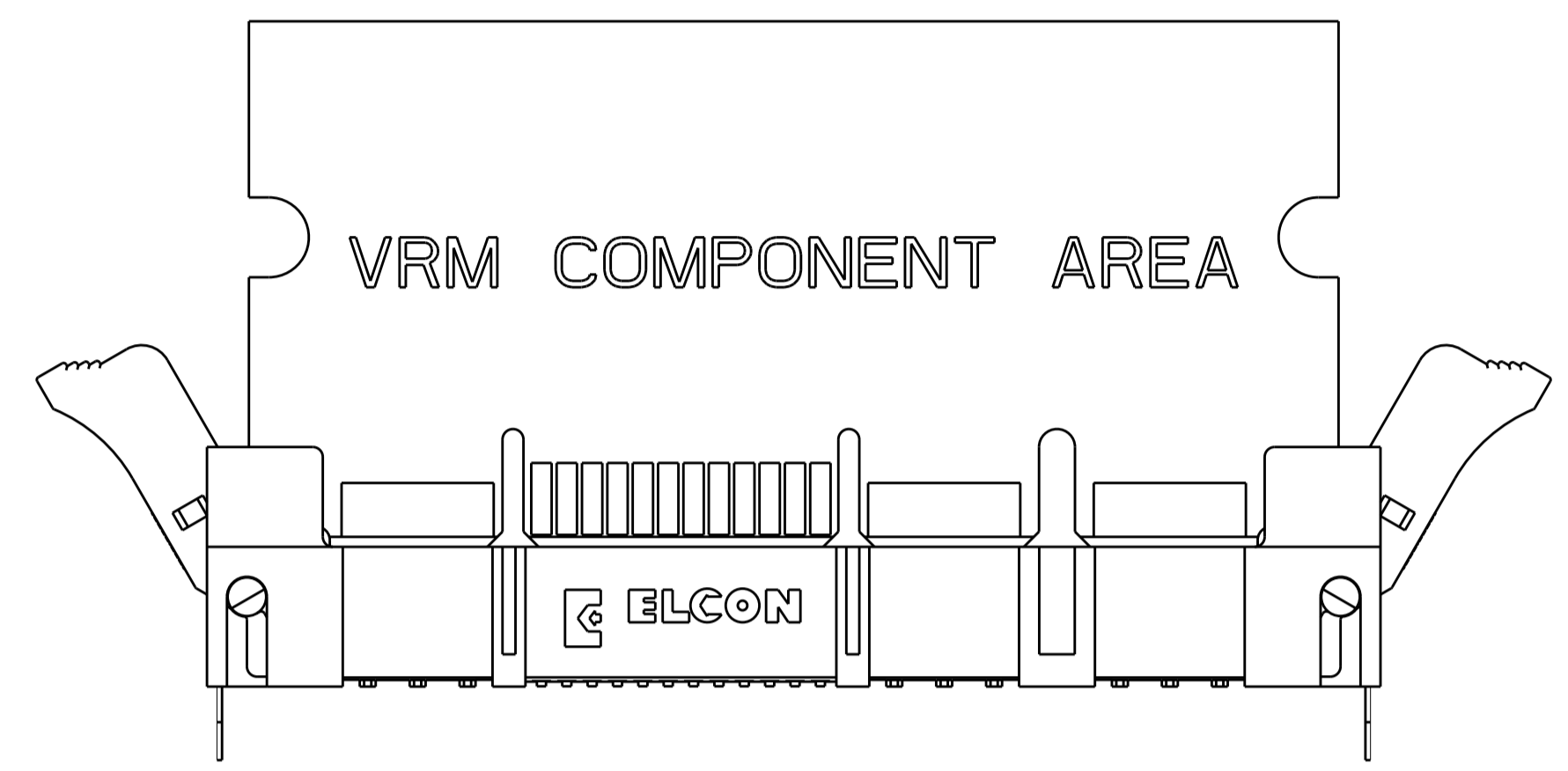

THE COMPLETE REMOVAL OF THE MODULE WILL BE DONE BY PULLING IT STRAIGHT UP THROUGH THE BOARD SUPPORT TOWERS WITH TWO HANDS TO INSURE VERTICAL REMOVAL.

THIS DRAWING IS A CONTROLLED DOCUMENT.		DWN: G. PETERS/DTI 25MAY2006	TE Connectivity
DIMENSIONS: mm		CHK: -	
TOLERANCES UNLESS OTHERWISE SPECIFIED: 0 PLC ±.1 1 PLC ±.5 2 PLC ±.25 3 PLC ±.1 4 PLC ±.1 ANGLES ±.2		APVD: N. REESER 25MAY2006	NAME: SOCKET CONNECTOR WITH LATCH, SMT P2-S24-P4 MINI CROWN EDGE
MATERIAL: -		FINISH: -	RESTRICTED TO: -
CUSTOMER DRAWING		SCALE: 1:1	SHEET 5 OF 5 REV: G2

Mouser Electronics

Authorized Distributor

Click to View Pricing, Inventory, Delivery & Lifecycle Information:

[TE Connectivity:](#)

[1926155-2](#)