

PART NUMBER
10119472-001LF
10119472-002LF

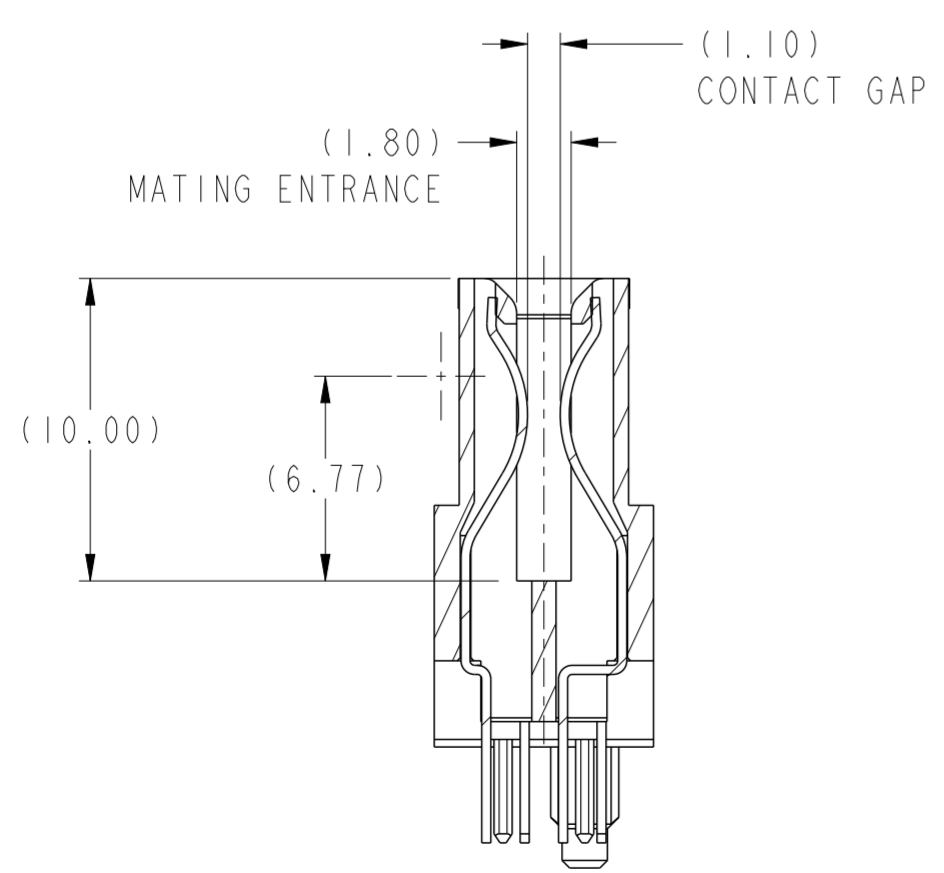
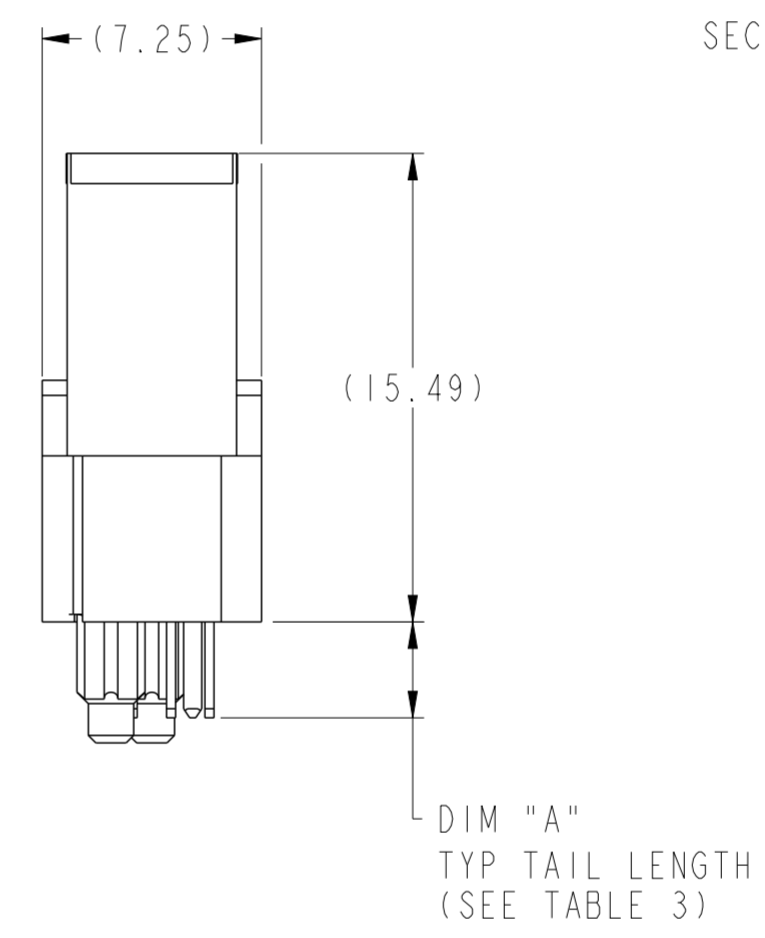
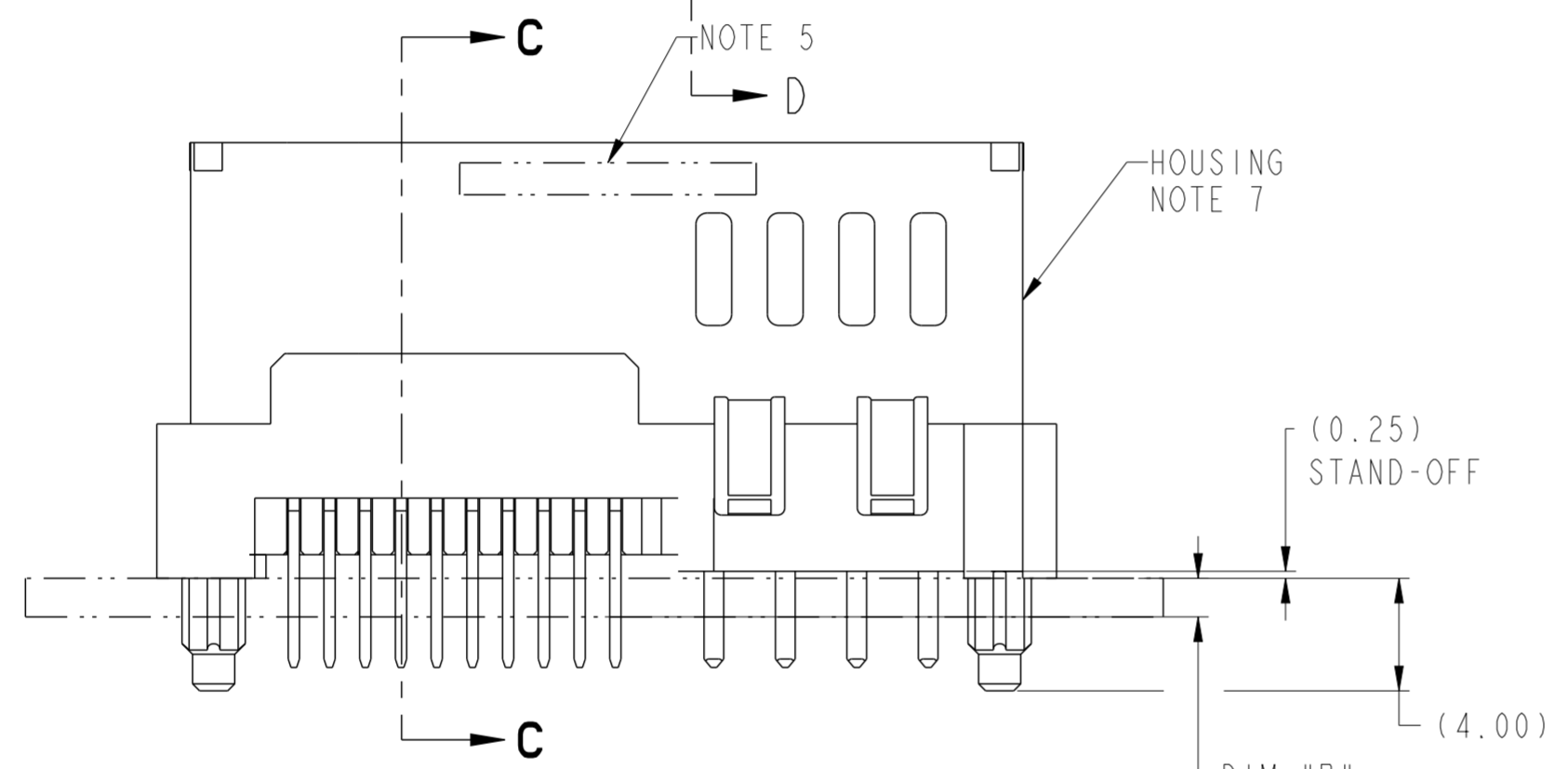
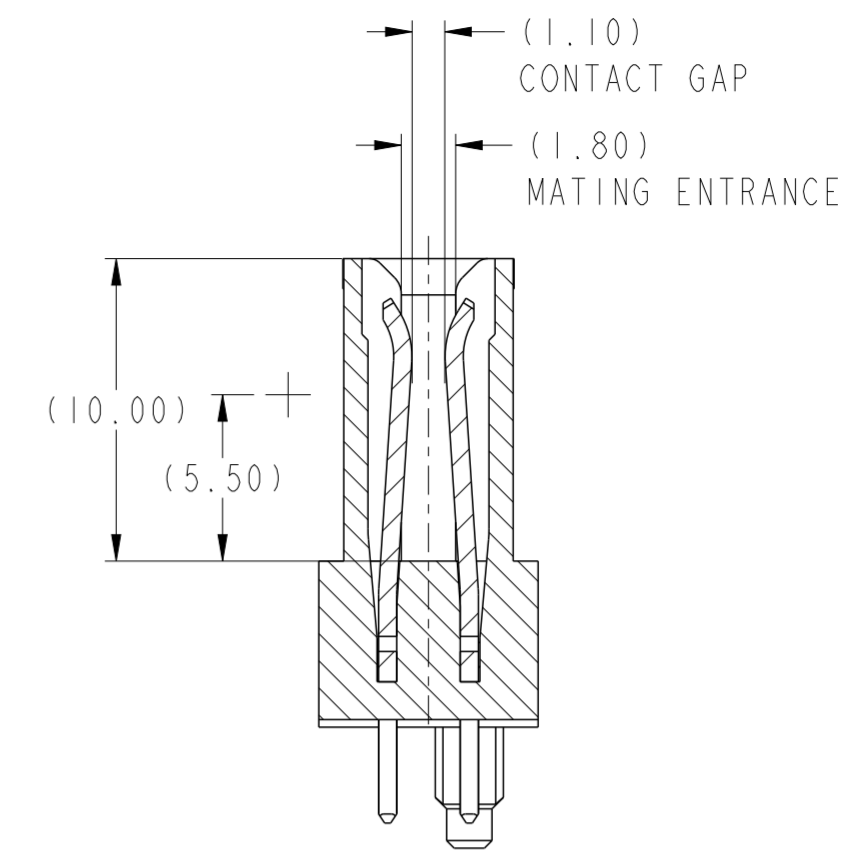
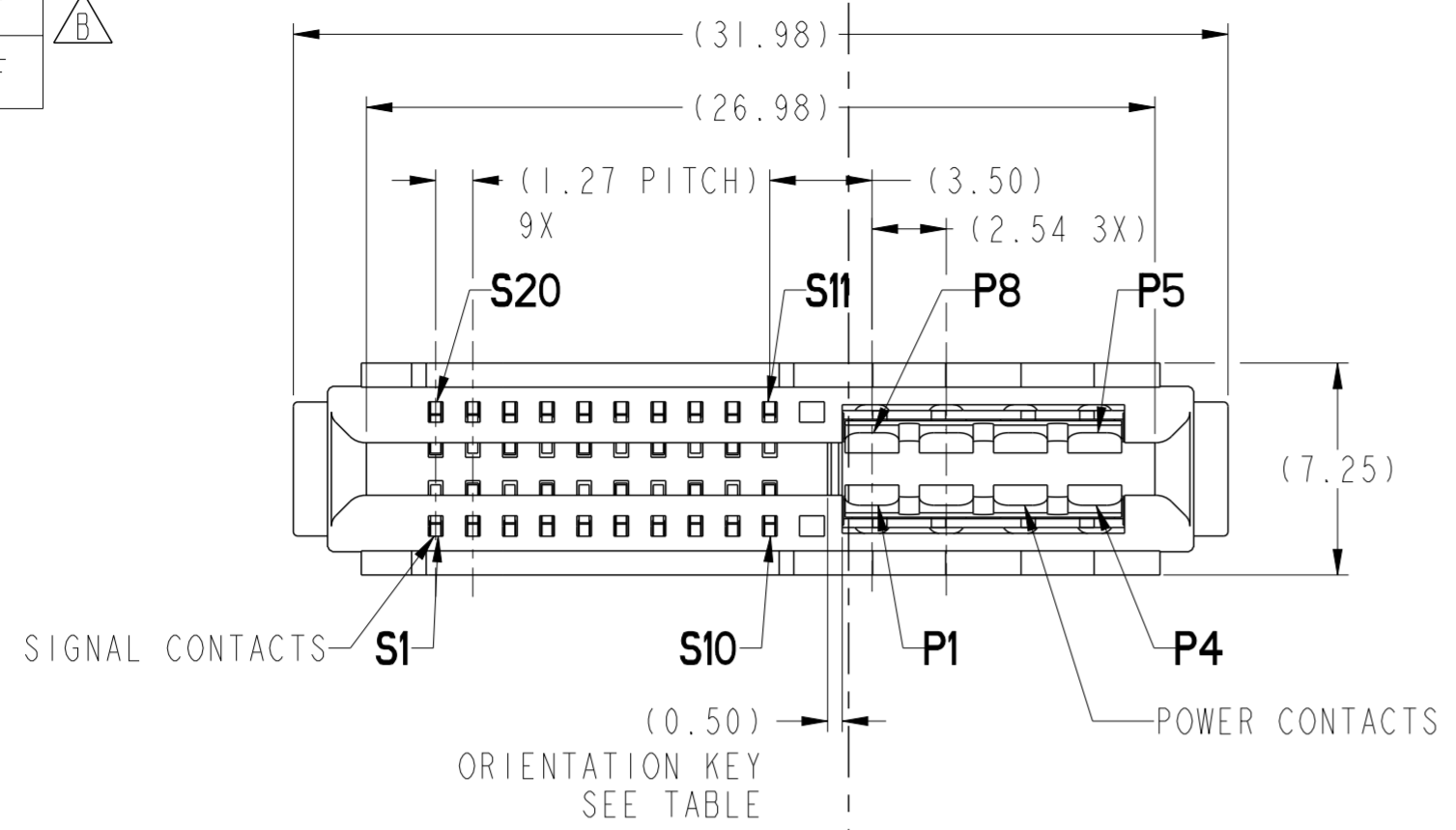

SECTION C-C

rev	ecn no	dr	date	spec ref	-	dr	Wei-Long Zhang	2011/11/15	projection	MM	size	A2	scale	4:1
A	-	HZ	2011-01-02	tolerance std	ASME Y14.5	eng	Julia Wang	2013/06/18			ecn no	ELX-DG-14988-1	rel level	Released
AI	-	ERIC	2013-01-24	tolerances unless otherwise specified	ASME Y14.5	chr	-	product family						
-	-	-	-	surface	✓	appr	Pei-Ming Zheng	2013/06/18			rel level	Blue	rev	B
-	-	-	-	linear	0.X ±0.3	0.XX ±0.10	0.XXX ±0.050	angular	0° ±2°	www.fci.com	cat. no.	-	Product - Customer Drw	sheet 1 of 5

PDS: Rev :B

STATUS:Released

Printed: Jun 18, 2013

Copyright FCI. FCI

PART NUMBER
10119472-003
10119472-003LF
10119472-004
10119472-004LF

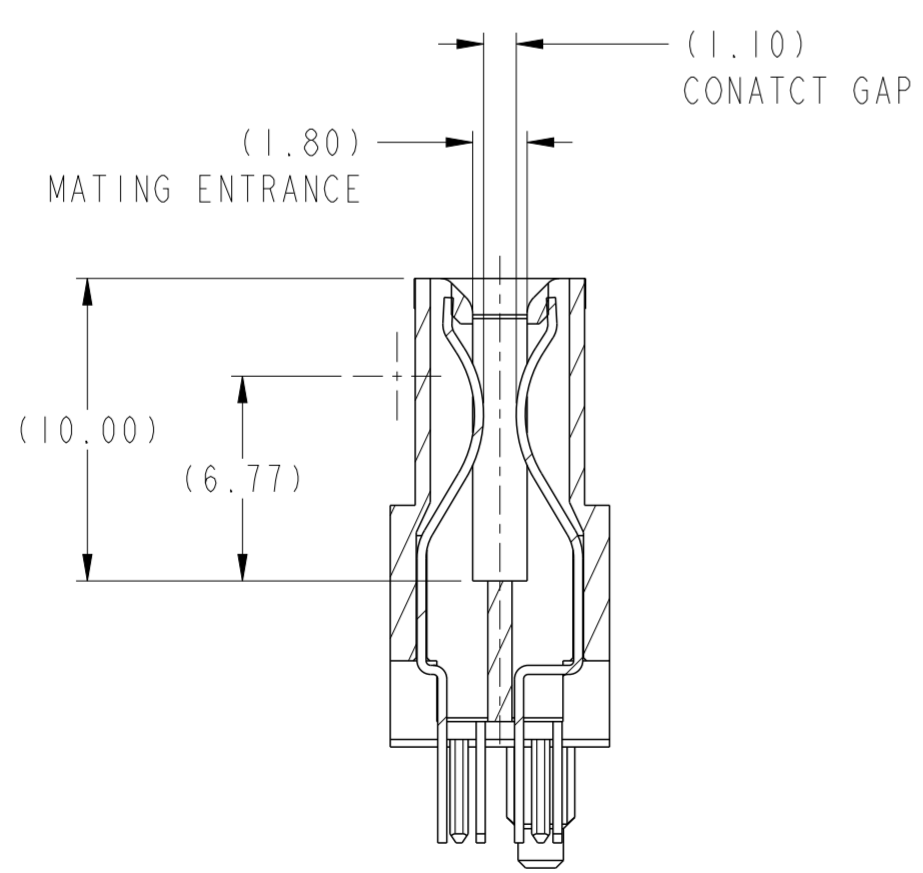
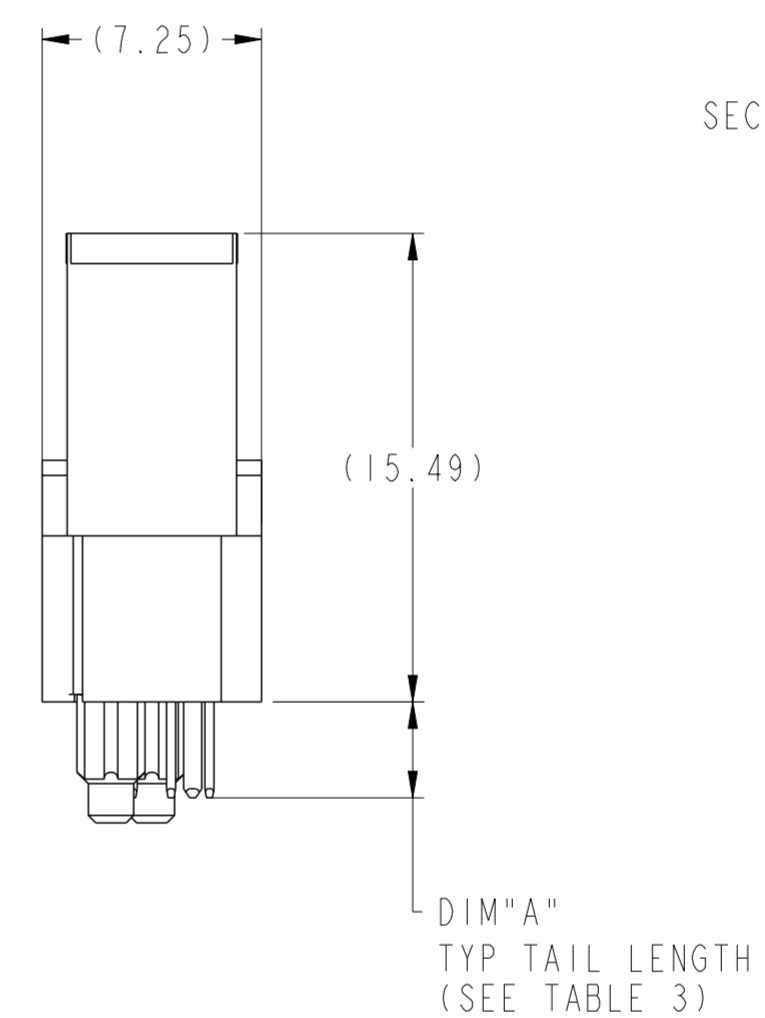
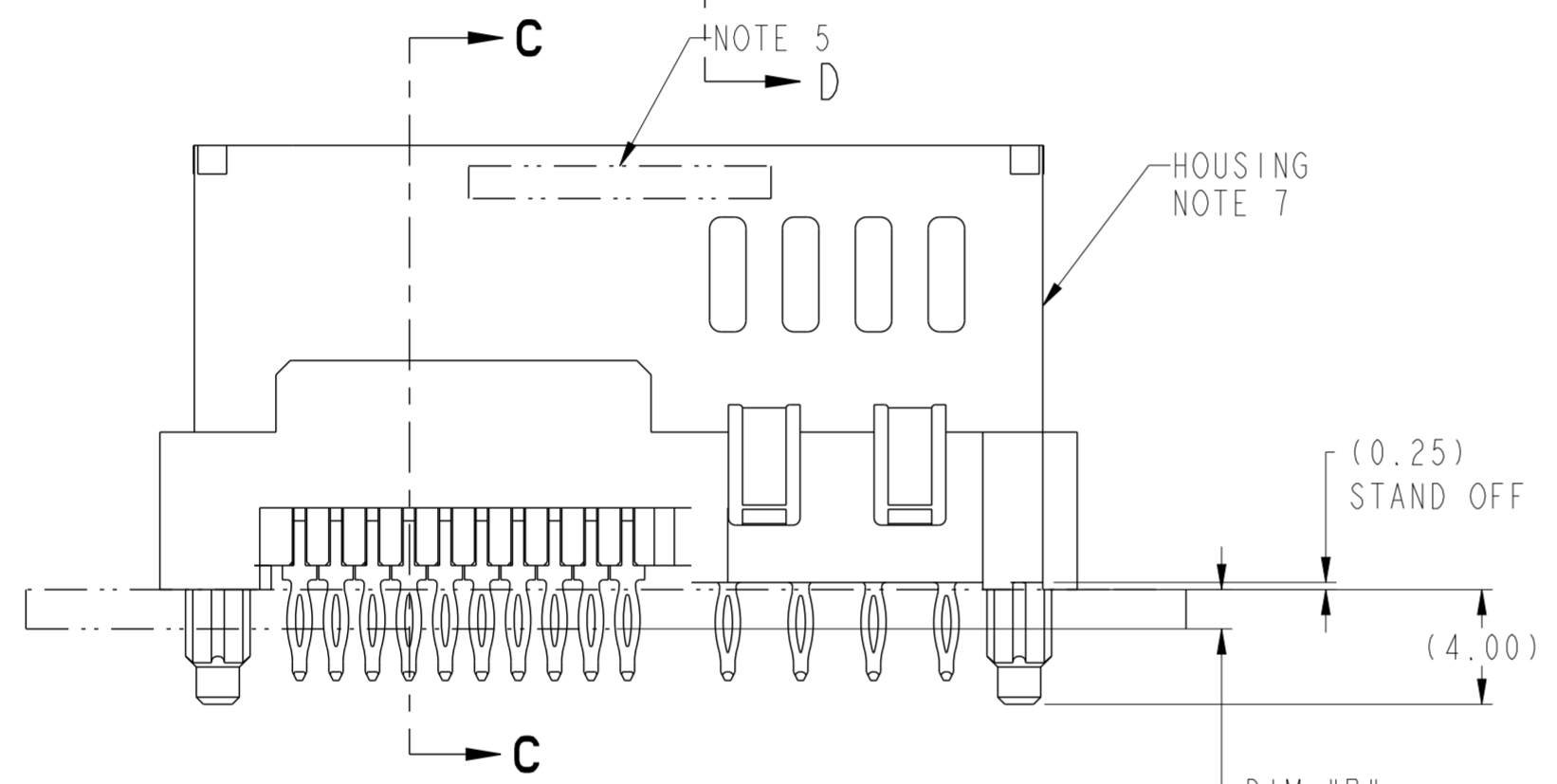
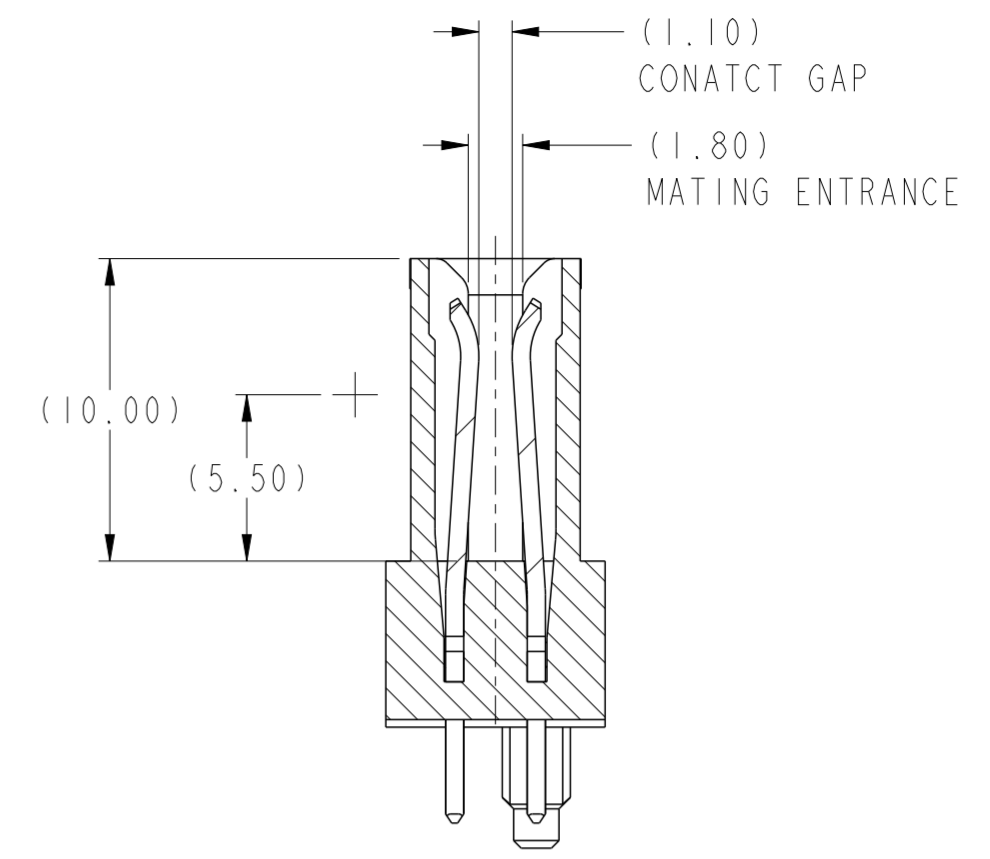
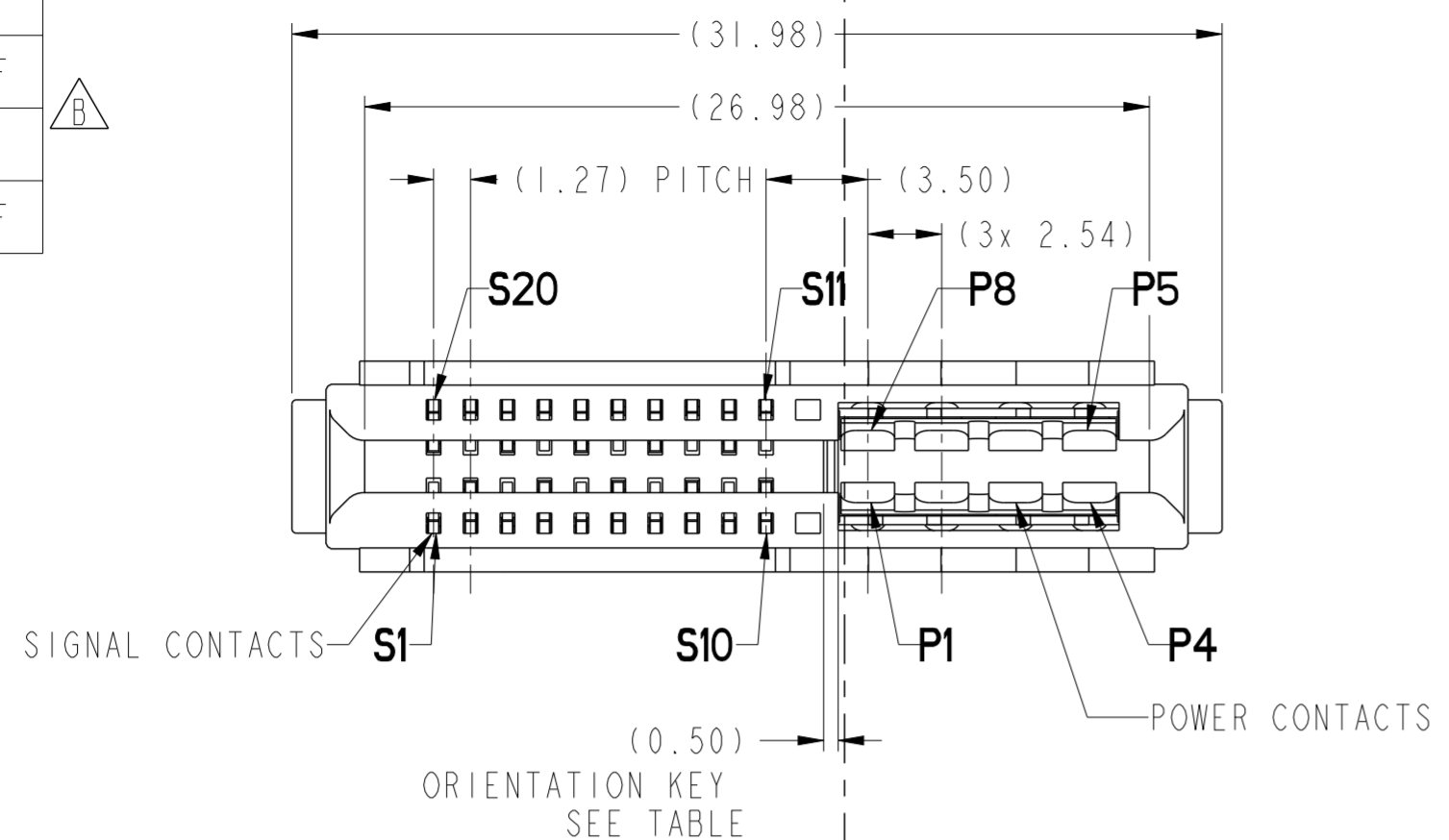

SECTION C-C

rev	ecn no	dr	date	spec ref	dr	2011/11/15	projection	MM	size	A2	scale	4:1	
A	-	HZ	2011-01-02	tolerance std	eng	Julia Wang	2013/06/18	chr	-	ecn no	ELX-DG-14988-1	rel level	Released
-	-	-	-	ASME Y14.5	apppr	Pei-Ming Zheng	2013/06/18	product family	HPCE	rel level	Released		
-	-	-	-	surface	linear	0.X	±0.3	FCI	VERT RECT (20S+8P)	dwg no	10119472	rev	B
-	-	-	-	ASME Y14.5	angular	0°	±2°	www.fci.com	cat. no.	Product - Customer Drw	sheet 2 of 5		

PDS: Rev :B

STATUS:Released

Printed: Jun 18, 2013

Copyright FCI. FCI

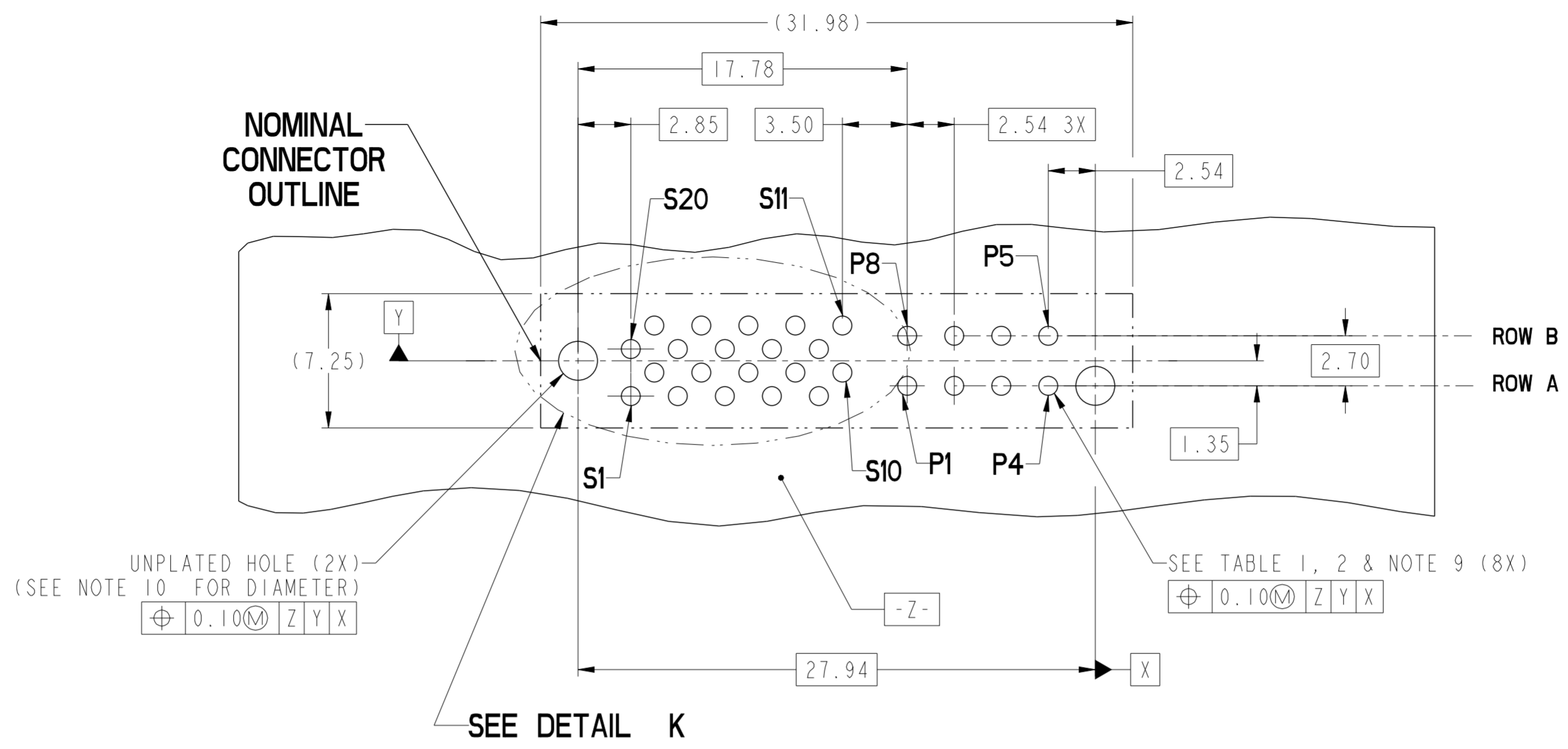

SEE DETAIL K

SEE TABLE 1, 2 & NOTE 9 (20X)

0.10 Z Y X

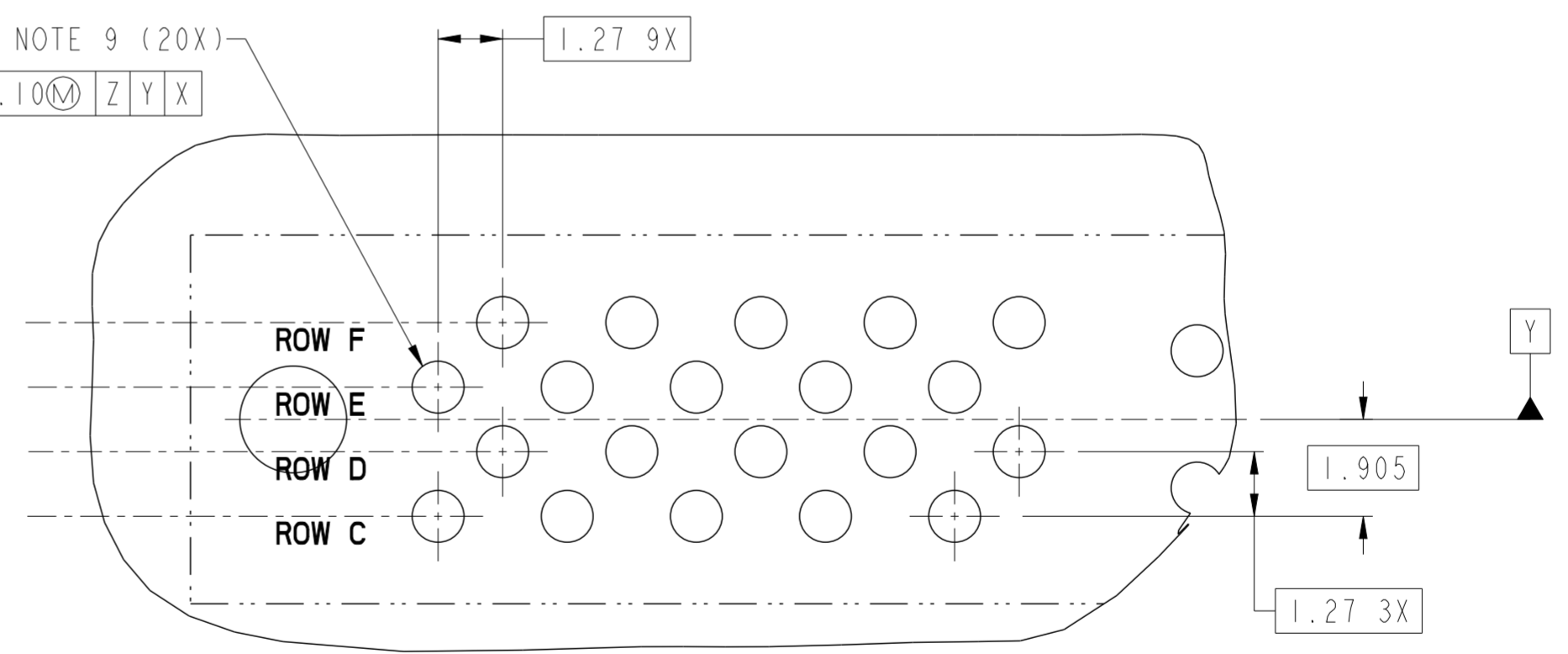

DETAIL K
SCALE 8:1

RECOMMENDED
PCB LAYOUT VIEWED
FROM CONNECTOR SIDE

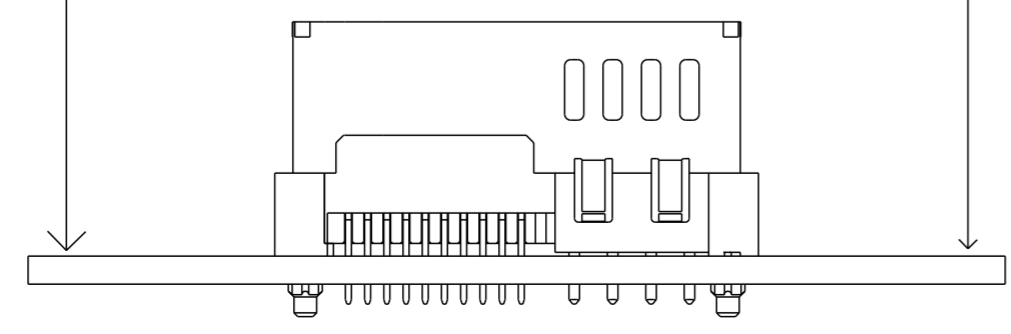

spec ref	-	dr	Wei-Long Zhang	2011/11/15	projection	MM	size	A2	scale	4:1
tolerance std	ASME Y14.5	eng	Julia Wang	2013/06/18			ecn no	ELX-DG-14988-1	rel level	Released
TOLERANCES UNLESS OTHERWISE SPECIFIED		chr	-	product family						
surface	linear	appr	Pei-Ming Zheng	2013/06/18			VERT RECT (20S+8P) HIGH POWER CARD EDGE		dwg no 10119472	rev B
ASME Y14.5	angular	www.fci.com		cat. no.	-		Product - Customer Drw		sheet 3 of 5	

CONTACT TYPE	TOP LAYER DESCRIPTION	TABLE 1 (HPCE / SOLDER TAILS) PLATED THROUGH-HOLE REQUIREMENTS				
		DRILLED HOLE DIAMETER	COPPER THICKNESS	TIN-LEAD THICKNESS	TIN THICKNESS	FINISHED HOLE DIAMETER
POWER & SIGNAL	TIN-LEAD	1.10-1.16 (1.15 DRILL)	0.025 - 0.050	0.005 - 0.015	--	0.94 - 1.10
	IMMERSION TIN	1.10-1.16 (1.15 DRILL)	0.025 - 0.050	--	0.9 - 1.5um	0.94 - 1.10
	COPPER (SEE NOTE 8)	1.10-1.16 (1.15 DRILL)	0.025 - 0.050	--	--	0.94 - 1.10

CONTACT TYPE	TOP LAYER DESCRIPTION	TABLE 2 (HPCE / PRESS-FIT TAILS) PLATED THROUGH-HOLE REQUIREMENTS				
		DRILLED HOLE DIAMETER	COPPER THICKNESS	TIN-LEAD THICKNESS	TIN THICKNESS	FINISHED HOLE DIAMETER
POWER & SIGNAL	TIN-LEAD	0.81-0.86 (0.85 DRILL)	0.025 - 0.050	0.005 - 0.015	--	0.65 - 0.80
	IMMERSION TIN	0.81-0.86 (0.85 DRILL)	0.025 - 0.050	--	0.9 - 1.5um	0.70 - 0.80
	COPPER (SEE NOTE 8)	0.81-0.86 (0.85 DRILL)	0.025 - 0.050	--	--	0.70 - 0.80

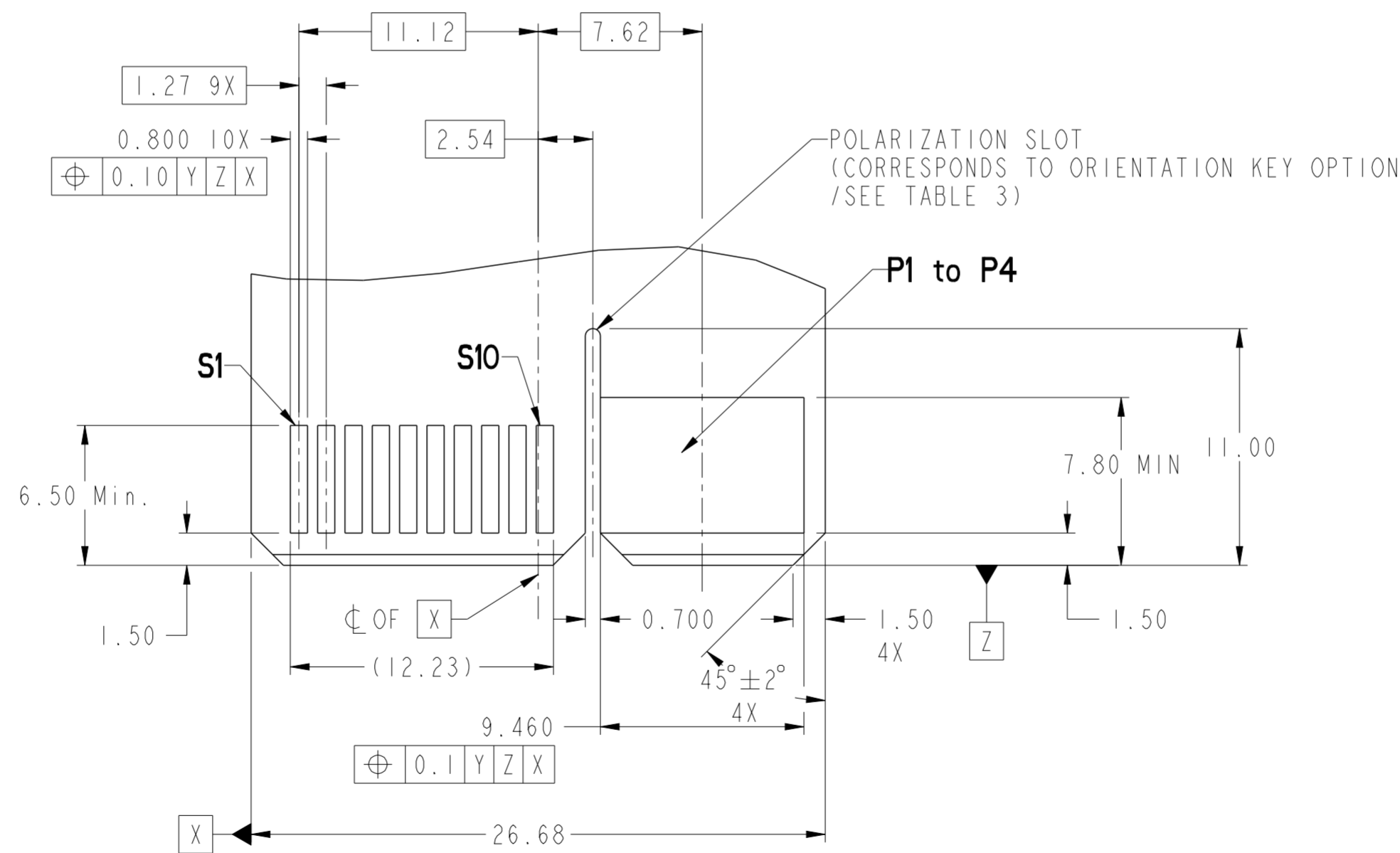

RECOMMENDED MATING BOARD FOOTPRINT

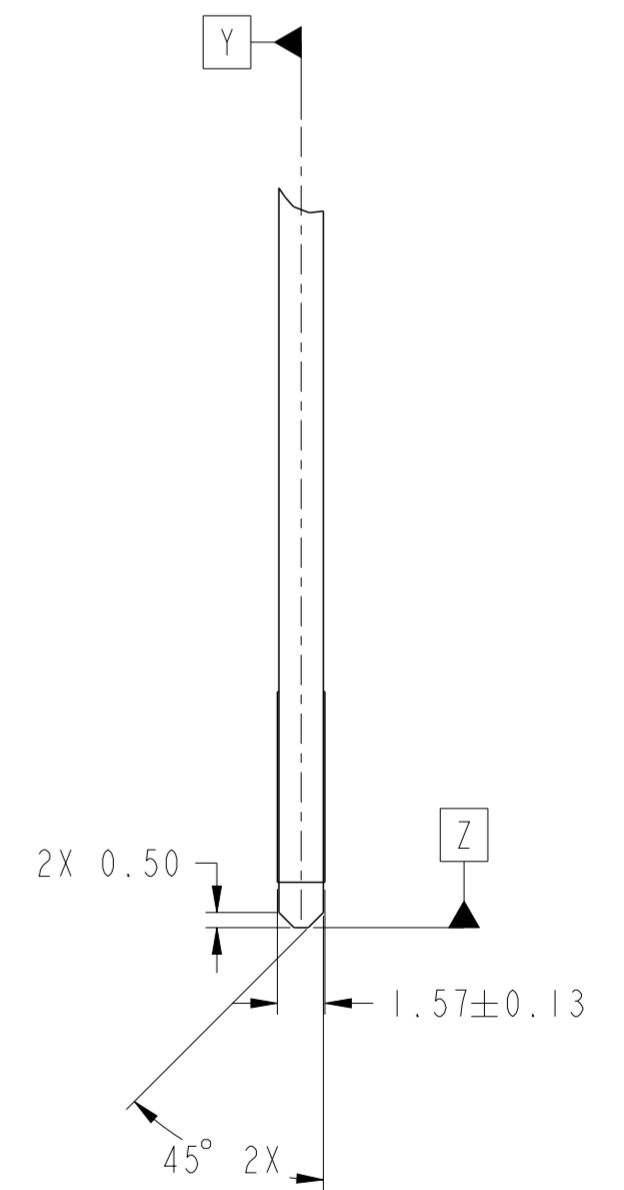

spec ref	-	dr	Wei-Long Zhang	2011/11/15	projection	MM	size	A2	scale	4:1
tolerance std	ASME Y14.5	eng	Julia Wang	2013/06/18	chr	-	ecn no	ELX-DG-14988-1	rel level	Released
surface	linear	appr	Pei-Ming Zheng	2013/06/18	product family	HPCE	rel level	Blue	rev	B
ASME Y14.5	angular	0°	±0.3	±0.10	±0.050	www.fci.com	cat. no.	-	Product - Customer Draw	sheet 4 of 5

HPCE PART NUMBER (TABLE 3)

PART NUMBER	TAIL TYPE	ORIENTATION KEY	DIM "A" TYPICAL TAIL LENGTH	DIM "B" RECOMMENDED BOARD THICKNESS
10119472-001LF	SOLDER	YES	3.17 ±0.25	1.59 - 2.38
10119472-002LF	SOLDER	NO		
10119472-003	PRESS-FIT	YES	3.17 ±0.25	1.57 MIN
10119472-003LF	PRESS-FIT	YES		
10119472-004	PRESS-FIT	NO		
10119472-004LF	PRESS-FIT	NO		

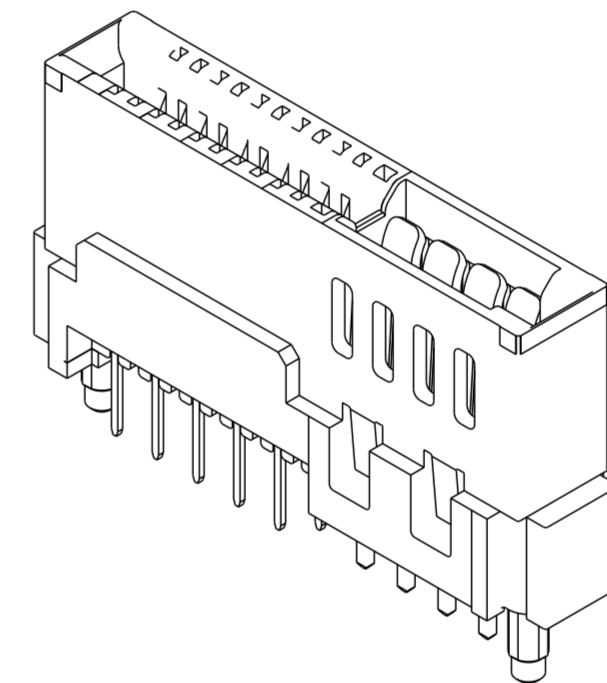

NOTES:

- CONNECTOR MATERIALS:
HOUSING: HIGH TEMPERATURE THERMAL PLASTIC, BLACK
UL 94V-0 COMPLIANT
CONTACTS: HIGH PERFORMANCE COPPER ALLOY.
- CONTACT FINISH REF. GS-12-604 SECTION 5.2.
- PRODUCT SPECIFICATION: GS-12-604.
- APPLICATION SPECIFICATION: GS-20-128.
- PRODUCT MARKING (FCI - PART NUMBER & DATE CODE) ON HOUSING IN AREA SHOWN.
- PACKAGING MEETS FCI SPECIFICATION GS-14-937.
- HOUSING COMPONENT WILL WITHSTAND EXPOSURE TO 260°C PEAK TEMPERATURE FOR 60 SECONDS IN A CONVECTION, INFRA-RED, OR VAPOR PHASE REFLOW OVEN.
- COPPER PLATING THICKNESS IN CENTER OF VIA-HOLE CAN BE NO MORE THAN 0.003 LESS THAN OTHER AREAS.
- ALL HOLE SIZES ARE FINISHED HOLE SIZES.
- MOUNTING HOLES ARE UNPLATED
 \varnothing 2.40 +/- 0.1 FOR PRESS-FIT TAILS
 \varnothing 2.18 +/- 0.03 FOR SOLDER TAILS

11. A Δ SYMBOL WILL BE NEXT TO ANY DIMENSION, VIEW, OR NOTE WHICH HAS BEEN MODIFIED WITH THE CURRENT DRAWING REVISION.

spec ref	-	dr	Wei-Long Zhang	2011/11/15	projection	MM	size	A2	scale	4:1	
tolerance std	ASME Y14.5	eng	Julia Wang	2013/06/18			ecn no	ELX-DG-14988-1			
surface	✓	chr	-	appr			Pei-Ming Zheng	2013/06/18	product family	HPCE	rel level
linear	0.X ±0.3 0.XX ±0.10 0.XXX ±0.050	angular	0°	±2°	www.fci.com	cat. no.	-	Product - Customer Drw	sheet 5 of 5	rev	B