

FKS ATO® Style Blade Fuse Rated 32V

RoHS

Blade Fuses



Specifications

DIN 72581-3C
ISO 8820-3

Insulating body: Out of thermoplastic (UL 94-V0, heat-resistant)
Cover: Out of thermoplastic (V0, transparent),
Visible melting-element
Shunt: red, not transparent

Connections: Blade contacts
Copper alloy, gal. Sn
Edge-protected

Breaking capacity: 1,000 A, 32 VDC

The FKS-32 is an ATO style blade fuse rated at 32V, featuring a three part construction with copper contacts for excellent reliability in harsh environment conditions and low voltage drop. Current ratings 0.5A thru 40A. With see-through cover for easy detection of blown fuses.

FSK-32 ist eine ATO-Flachstecksicherung mit 32V Nennspannung. Merkmale sind dreiteiliger Aufbau mit Kupferkontakten, niedriger Spannungsabfall und hohe Zuverlässigkeit unter rauen Umgebungsbedingungen. Nennstrom 0,5A bis 40A, transparente Abdeckung zur leichten Erkennung durchgebrannter Sicherungen.

Time-Current Characteristics / Schmelzeit-Grenzwerte

% of Rating % des Nennstromes	Opening Time Min / Max (s) Schmelzcharakteristik Min / Max (s)
110	100 h / –
135	750 ms / 1,800 s
200	150 ms / 5 s
350	40 ms / 500 ms
600	20 ms / 100 ms

Part Number Artikel-Nr.	Current Rating Nennstrom	Housing Color Kennfarbe	Typ. Voltage Drop Typ. Spannungsfall		Cold Resistance Kaltwiderstand	I ² t
			Standard DIN max.	Littelfuse max.		
162.6185.350_	0.5 A*		–	320 mV	450 mΩ	0.70 A ² s
162.6185.410_	1 A		–	150 mV	108 mΩ	2.00 A ² s
162.6185.420_	2 A		–	130 mV	47.2 mΩ	8.00 A ² s
162.6185.430_	3 A		175 mV	140 mV	30.5 mΩ	15.0 A ² s
162.6185.440_	4 A		175 mV	120 mV	22.5 mΩ	25.0 A ² s
162.6185.450_	5 A		175 mV	145 mV	16.5 mΩ	35.0 A ² s
162.6185.475_	7.5 A		150 mV	115 mV	11.5 mΩ	60.0 A ² s
164.6185.510_	10 A		125 mV	95 mV	6.80 mΩ	110 A ² s
164.6185.515_	15 A		125 mV	90 mV	4.50 mΩ	250 A ² s
164.6185.520_	20 A		125 mV	90 mV	3.40 mΩ	648 A ² s
164.6185.525_	25 A		110 mV	80 mV	2.50 mΩ	600 A ² s
164.6185.530_	30 A		100 mV	80 mV	1.85 mΩ	1,070 A ² s
162.6185.535_	35 A*		100 mV	75 mV	1.50 mΩ	1,600 A ² s
162.6185.540_	40 A*		100 mV	100 mV	1.35 mΩ	2,000 A ² s
160.6185.000_	Shunt*		–	42 mV	0.73 mΩ	9,000 A ² s

* Not mentioned in the standards

Last figure of part number = packaging code, see Section "Packaging Index," pg. 157. Corresponding holder see Section "Fuse Holders."

FKS ATO® Style Blade Fuse Rated 32V

Dimensions in mm / Maße in mm

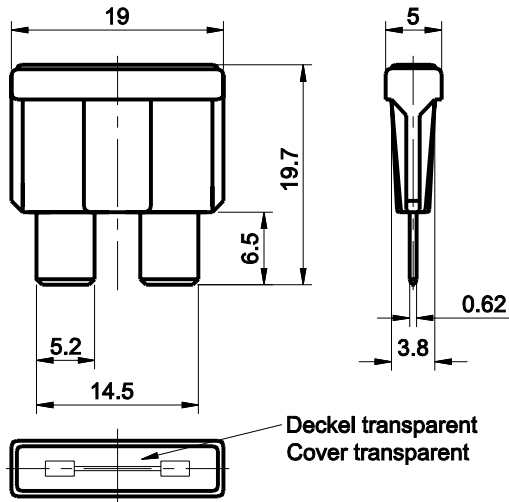

Pre-arcing Time - limits / Schmelzeit-Grenzwerte DIN

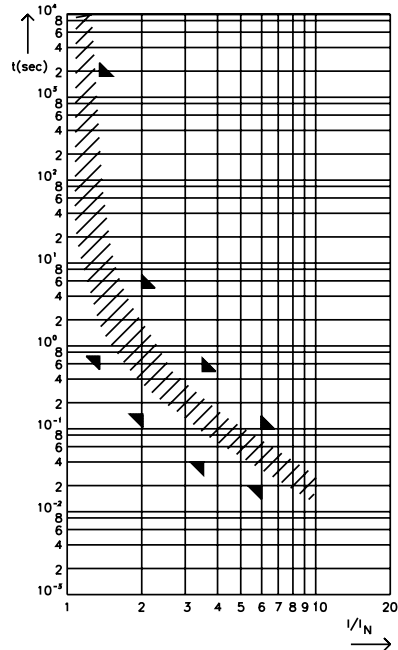

FI = 1.33 (max. operating current: $0.75 \times I_{rat}$ at 23°C)