

**FKS ATO® Style Blade Fuse Rated 80V**



Blade Fuses



**Specifications**

UL 248 Special Purpose Fuses  
cULus Recognized: File No. E211637

**Interrupting Rating:** 1000 A @ 80 VDC  
**Insulating body:** Out of thermoplastic (UL 94-V0, heat-resistant)  
**Cover:** Out of thermoplastic (UL 94-V0, heat-resistant)  
 Red, not transparent  
**Terminals:** Blade contacts  
 Copper alloy, gal. Sn plated  
 Edge-protected

**Packaging:**

Series	Pack Size
166.7000.xxx6	100
166.7000.xxx2	500

The FKS-80 is an ATO® style blade fuse rated at 80V, featuring a three part construction with copper contacts for excellent reliability in harsh environment conditions and low voltage drop. Current ratings 3A thru 30A. Filled with arc-quenching material.

FKS-80 ist eine ATO-Flachstecksicherung mit 80V Nennspannung. Merkmale sind dreiteiliger Aufbau mit Kupferkontakten, niedriger Spannungsabfall und hohe Zuverlässigkeit unter rauen Umgebungsbedingungen. Nennstrom 3A bis 30A. Gefüllt mit Lichtbogen löschendem Material.

**Time-Current Characteristics / Schmelzzeit-Grenzwerte**

% of Rating % des Nennstromes	Opening Time Min / Max (s) Schmelzcharakteristik Min / Max (s)
110	360,000 s / –
135	0.500 s / 300 s
200	0.150 s / 20 s
350	0.040 s / 0.500 s
600	0.020 s / 0.100 s

Part Number Artikel-Nr.	Current Rating Nennstrom	Housing Color Kennfarbe	Typ. Voltage Drop Typ. Spannungsfall	Cold Resistance Kaltwiderstand	I <sup>2</sup> t
166.7000.430_	3 A		145 mV	39.0 mΩ	8.10 A <sup>2</sup> s
166.7000.440_	4 A		140 mV	29.0 mΩ	14.4 A <sup>2</sup> s
166.7000.450_	5 A		140 mV	20.6 mΩ	24.3 A <sup>2</sup> s
166.7000.475_	7.5 A		120 mV	11.5 mΩ	44.5 A <sup>2</sup> s
166.7000.510_	10 A		110 mV	7.90 mΩ	86.4 A <sup>2</sup> s
166.7000.515_	15 A		110 mV	4.60 mΩ	162 A <sup>2</sup> s
166.7000.520_	20 A		110 mV	3.30 mΩ	475 A <sup>2</sup> s
166.7000.525_	25 A		105 mV	2.27 mΩ	950 A <sup>2</sup> s
166.7000.530_	30 A		100 mV	1.79 mΩ	1,500 A <sup>2</sup> s

Corresponding holder see Section "Fuse Holders."

## FKS ATO® Style Blade Fuse Rated 80V

Dimensions in mm / Maße in mm

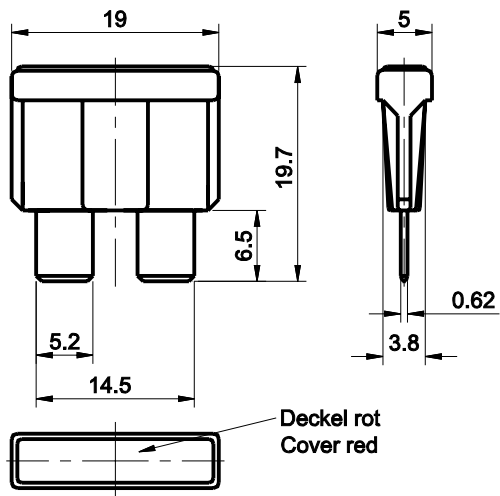

Pre-arcing Time - limits / Schmelzeit-Grenzwerte DIN

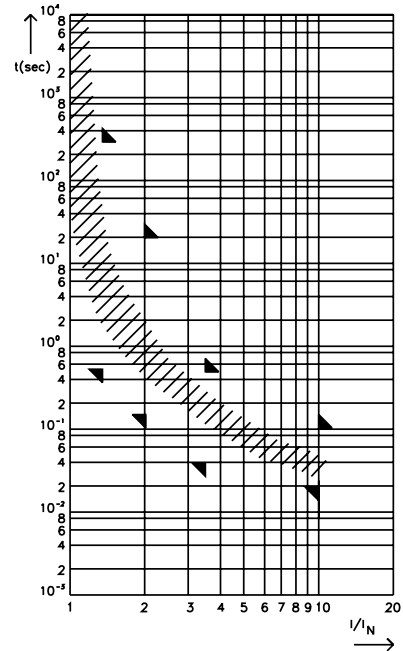

FI = 1.43 (max. operating current: 0.7 x I<sub>rat</sub> at 23°C)