



Expertise Applied | Answers Delivered



CIRCUIT
PROTECTION
SOLUTIONS FOR
AUTOMOTIVE
APPLICATIONS



Transportation

Automotive • Commercial Vehicle Products (CVP)

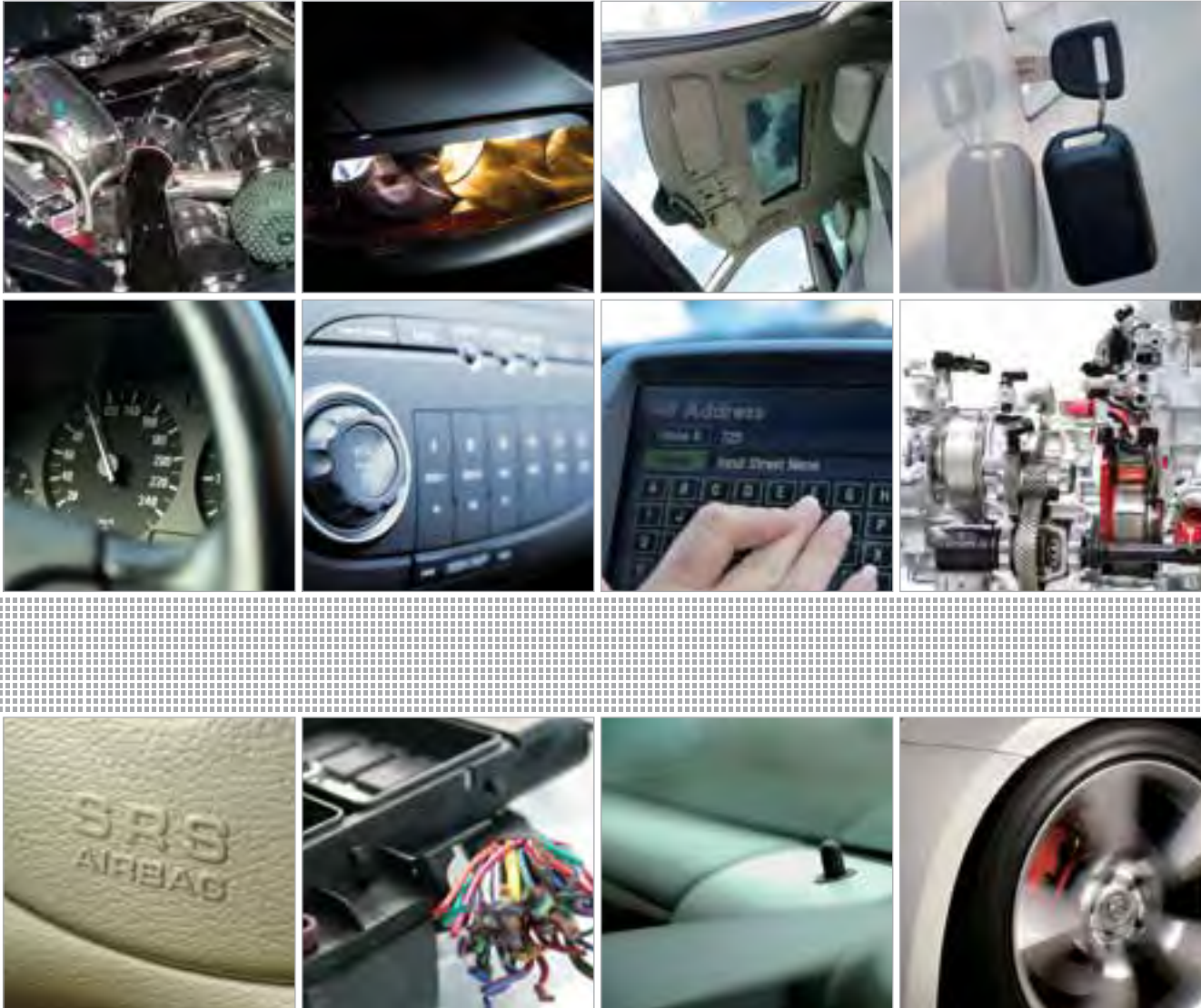

Our offering of automotive circuit protection solutions encompasses a wide range of applications:

- Powertrain** Engine Management
Transmission Control
Cooling Fan
Water Pump
- Safety** ABS
EPAS
Air Bag
Chassis Control
- Comfort** Window Lift
Sun Roof
Door Lock
Power Seat
HVAC
- Infotainment** Dashboard
Navigation
In-Car Entertainment
- Fuse Box** Wire Harness
- Power Supply** Generator
- Lighting** HID Headlight
Headlight Leveling
Directional Lighting



portfolio of Littelfuse automotive technologies, product & services

Passenger Automobiles | Agriculture & Construction Equipment | Commercial & Recreational Vehicles | Marine | Aftermarket

SERVICES

Product Technologies Plus Application Design Evaluation Services

Littelfuse is the world leader in circuit protection. We offer an extensive selection of circuit protection technologies for Automotive applications. Littelfuse circuit protection expert staff can assist you in designing circuit protection for your most demanding applications. Solutions for over-current applications as well as over-voltage applications are available from Littelfuse.



CIRCUIT PROTECTION TECHNOLOGIES (1-6)

1. Fuses/Footprint Reduction—
MICRO2™, MICRO3™ fuses

2. High Current Distribution—
Bolt-down fuses and protectors for currents to 500A

3. Advanced Power Systems—
Low-current fuses for Electric and Hybrid Electric Vehicles

4. Battery Cable Protection—
CABLE PRO® protectors for mounting directly inline as part of a high power cable assembly

5. Medium Current Cartridge Fuses—MCASE™ cartridge fuses; considerably smaller than JCASE® and Low Profile JCASE® fuses

6. Modular Fuse Holder Assemblies—FLEX-MEGA® holders for MEGA® fuse

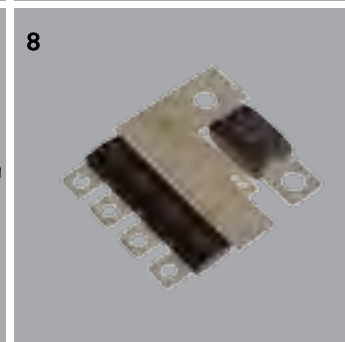
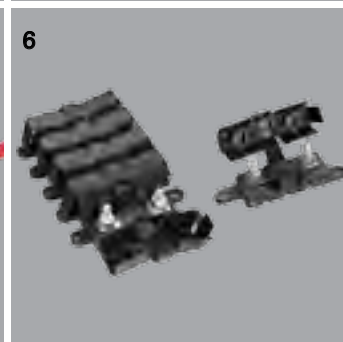
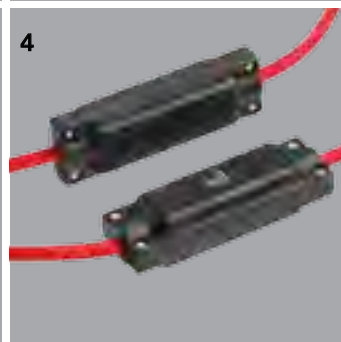
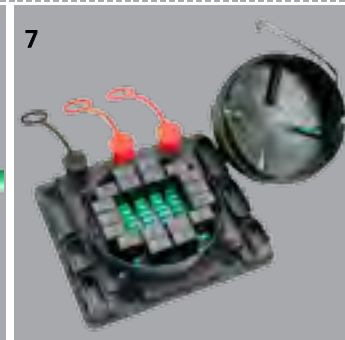
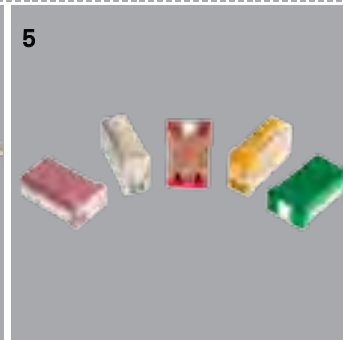

POWER DISTRIBUTION (7-8)

7. FLEC™—Customizable pre-tooled junction boxes

8. Masterfuse—High current distribution array

TABLE OF CONTENTS

Blade Fuses	1
Cartridge Fuses	39
Bolt-Down Fuses	46
Cable Fuses	73
Advanced Power Systems	76
PAL Fuses	82
Power Distribution Centers	91
Fuse Holders	132
Fuse Pullers	168
Specialty Products	171
Fuseology	176

HELPING TO MAKE THE WORLD A CLEANER PLACE TO LIVE

Littelfuse and the Environment

As members of the global community, we at Littelfuse have always strived to understand the impact of what we do, and of what we create, on the world around us. Because of this, our concern for the environment has always been an integral and fundamental part of our business. We continually work to balance our business objectives with the need to protect and improve the local and global environment.

Our Strategy for the Design of Eco-friendly Products

Littelfuse has established a focused program committed to developing high-performance eco-friendly products along with a comprehensive set of processing/reliability data and technical process expertise. This includes processes for eliminating, detecting and documenting the presence of hazardous materials such as

- Lead
- Cadmium
- Hexavalent Chromium
- Mercury
- Brominated flame-retardants (PBBs and PBDEs)

The Littelfuse strategy for eco-friendly products is specifically designed to help support our worldwide customers in their transition to Lead-Free processing.



All products considered to be lead-free are marked with this symbol.

Littelfuse defines lead-free as products which contain less than 1000ppm (0.1%) Lead, measured by weight of the entire product.



All RoHS compliant products are marked with this symbol.

Littelfuse follows the requirement set by the European Union for all RoHS compliant products. The European Union Directive 2002/95/EC RoHS restricts the use of Lead, Mercury, Hexavalent Chromium, Cadmium and Brominated flame-retardants (PBBs and PBDEs)

Visit www.littelfuse.com/lead-free for further information.

Blade Fuses



MICRO2™ Blade Fuse 32V	2
MICRO3™ Blade Fuse 32V	4
Low Profile MINI® Fuses Rated 58V	6
Low Profile MINI® 10.9mm Fuses Rated 58V	8
MINI® Blade Fuse Rated 32V	10
MINI® Blade Fuse Rated 58V	12
ATOF® Blade Fuse Rated 32V	14
ATO® Ag Blade Fuse Rated 32V	16
MAXI® Blade Fuse Rated 32V	18
MAXI® Blade Fuse Rated 58V	20
FK1 MINI® Style Blade Fuse Rated 32V	22
FUN MINI® Style Blade Fuse Rated 125V	24
FP1 MINI® Style PCB Fuse Rated 32V	25
FKS ATO® Style Blade Fuse Rated 32V	27
TAC ATO® Style Blade Fuse Rated 58V	29
FKS ATO® Style Blade Fuse Rated 80V	31
TF ATO® Style Blade Fuse Rated 90V	33
FK3 MAXI® Style Blade Fuse Rated 32V	34
TOE MAXI® Style Blade Fuse Rated 58V	36
FK3 MAXI® Style Blade Fuse Rated 80V	38

MICRO2™ BLADE FUSE 32V

RoHS



Description

The MICRO2™ Fuse is the new standard for vehicle circuit protection. Its sub-miniature design meets the need for more circuits to be protected while utilizing less space and its ability to cope with high temperatures in adverse environments makes the MICRO2™ Fuse the recommended choice for protection.

Specifications

Voltage Rating:	32 VDC
Interrupting Ratings:	1000A @ 32 VDC
Operating Temperature Range:	-40°C to +125°C
Terminals:	Ag plated zinc alloy
Housing Material:	PA66

Ordering Information

Part Number	Package Size
0327xxx.ZXS	4000
0327xxx.UXS	500
0327xxx.LXS	50

Dimensions

Dimensions in mm

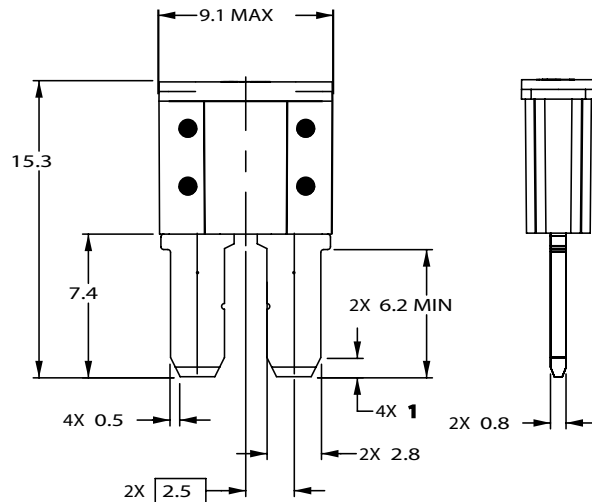

Time-Current Characteristics

% of Rating	Opening Time Min / Max
110	100 h / -
135	0.75 sec / 120 sec
160	0.30 sec / 50 sec
200	0.15 sec / 5 sec
350	0.04 sec / 0.50 sec
600	0.02 sec / 0.100 sec

Ratings

Part Number	Current Rating (A)	Housing Color	Typ. Voltage Drop (mV)	Cold Resistance (mΩ)	I ² t (A ² s)
0327005_	5 A		116 mV	17.4 mΩ	17 A ² s
032707.5_	7.5 A		106 mV	10.8 mΩ	47 A ² s
0327010_	10 A		102 mV	7.7 mΩ	89 A ² s
0327015_	15 A		94 mV	4.8 mΩ	189 A ² s
0327020_	20 A		91 mV	3.4 mΩ	397 A ² s
0327025_	25 A		90 mV	2.6 mΩ	585 A ² s
0327030_	30 A		88 mV	2.1 mΩ	1028 A ² s

MICRO2™ BLADE FUSE 32V

RoHS

Time-Current Characteristic Curves

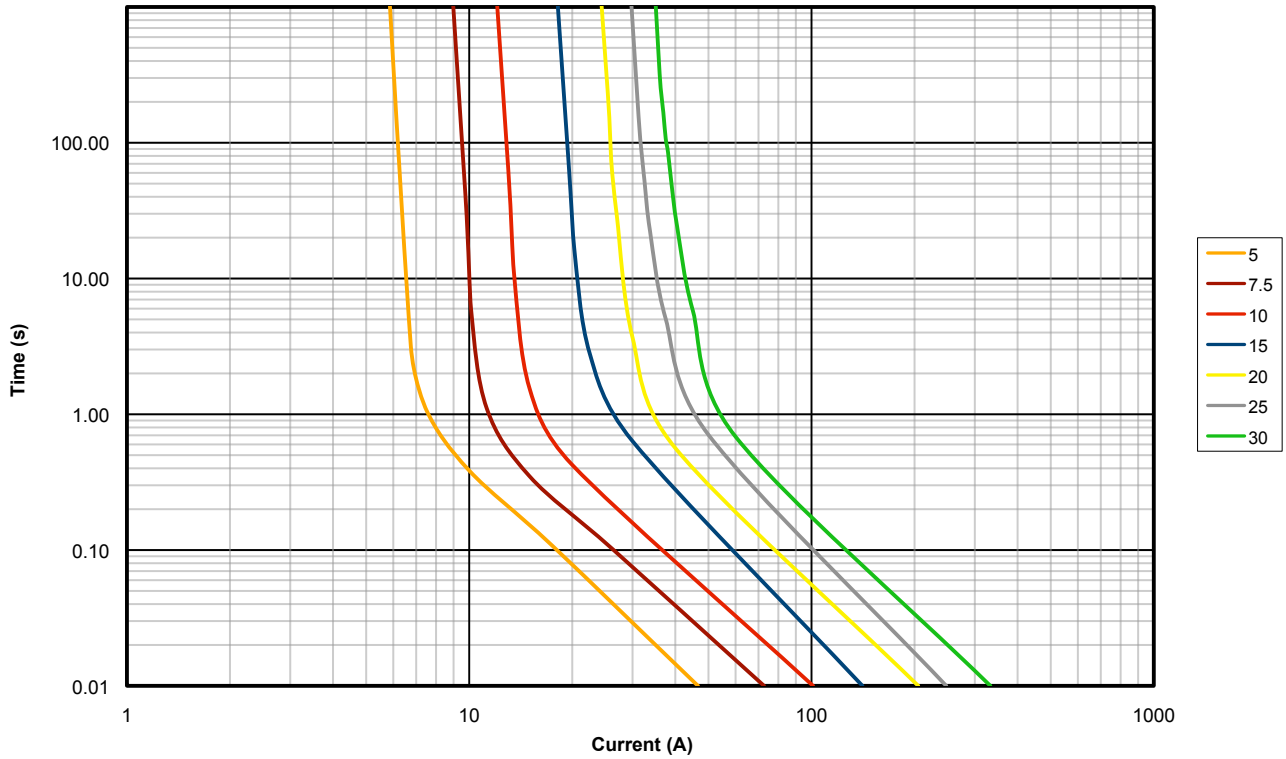

Temperature Rerating Curve

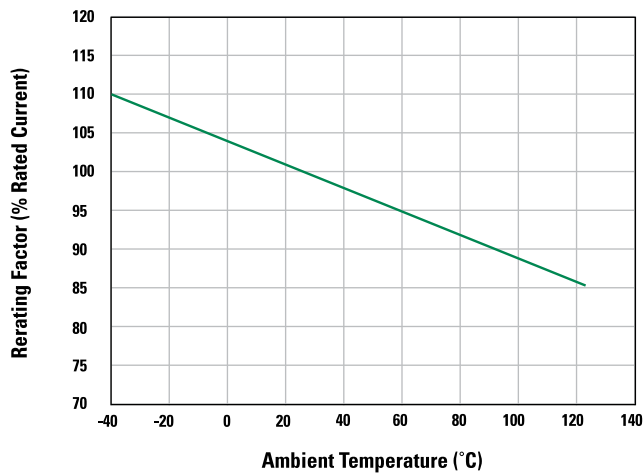

MICRO3™ BLADE FUSE 32V

RoHS



Description

The MICRO3™ Fuse is the new standard for vehicle circuit protection. The MICRO3™ Fuse has 3 terminals and 2 fuse elements with a common center terminal. Its sub-miniature design meets the need for more circuits to be protected while utilizing less space and its ability to cope with high temperatures in adverse environments makes the MICRO3™ Fuse the recommended choice for protection.

Time-Current Characteristics

% of Rating	Opening Time (Min / Max)
110	100 h / -
135	0.75 sec / 120 sec
160	0.30 sec / 50 sec
200	0.15 sec / 5 sec
350	0.04 sec / 0.50 sec
600	0.02 sec / 0.100 sec

Ratings

Part Number	Current Rating (A)	Housing Color	Typ. Voltage Drop (mV)	Cold Resistance (mΩ)	I ² t (A ² s)
0337005_	5 A		116 mV	17.4 mΩ	17 A ² s
033707.5_	7.5 A		106 mV	10.8 mΩ	47 A ² s
0337010_	10 A		102 mV	7.7 mΩ	89 A ² s
0337015_	15 A		94 mV	4.8 mΩ	189 A ² s

Specifications

Voltage Rating:	32 VDC
Interrupting Ratings:	1000A @ 32 VDC
Operating Temperature Range:	-40°C to +125°C
Terminals:	Ag plated zinc alloy
Housing Material:	PA66

Ordering Information

Part Number	Package Size
0337xxx.PXS	2000
0337xxx.LXS	50

Dimensions

Dimensions in mm

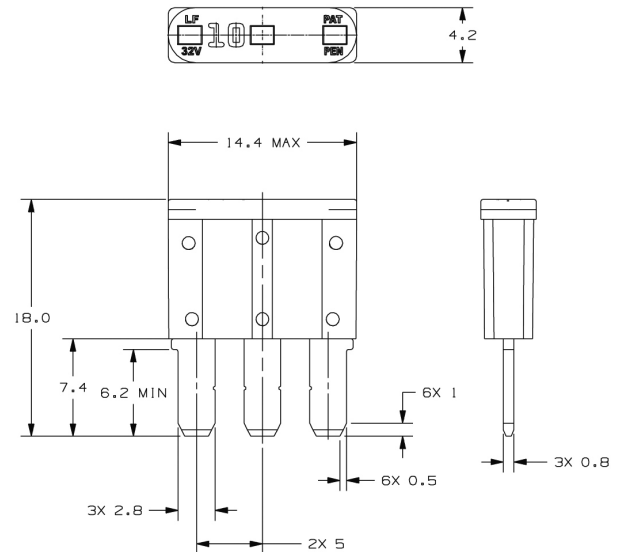

MICRO3™ BLADE FUSE 32V

RoHS

Time-Current Characteristic Curves

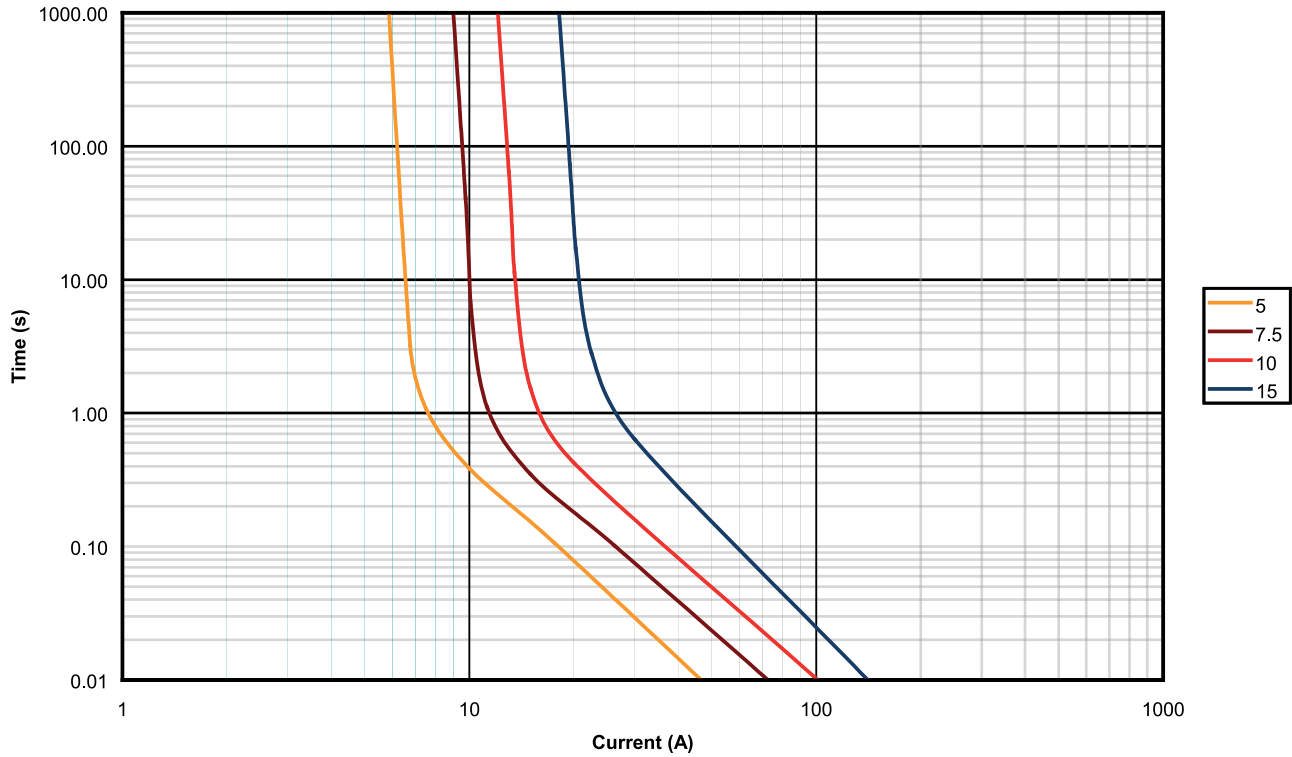

Temperature Derating Curve

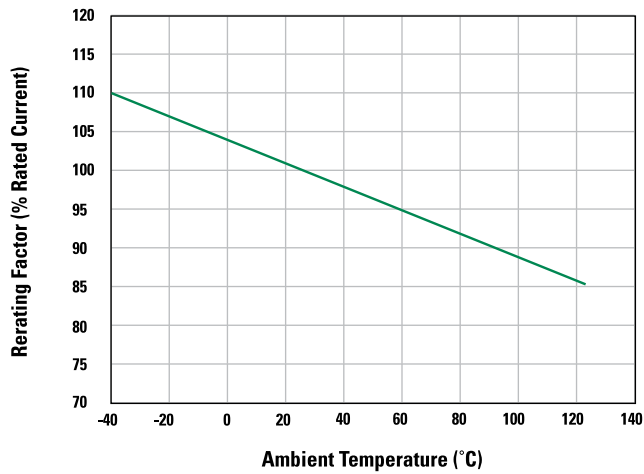

LOW PROFILE MINI® FUSES RATED 58V

RoHS



Specifications

Voltage Rating:	58 VDC
Interrupting Rating:	1000A @ 58 VDC
Operating Temperature Range:	-40°C to +125°C
Terminals:	Ag plated zinc
Housing Materials:	PA66

Ordering Information

Part Number	Package Size	Plating
0891xxx.NXS	5000	Ag
0891xxx.U	500	Ag
0891xxx.H	100	Ag

Dimensions

Dimensions in mm

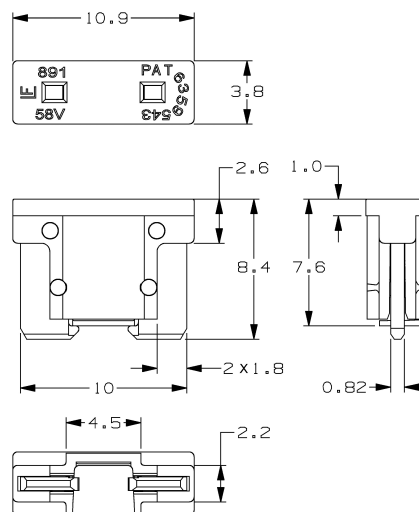

Description

The Low Profile MINI® fuse has similar performance characteristics as the standard MINI® fuse. The lower overall height allows for more space and weight savings. The Low Profile MINI® fuse is designed to mate with tuning-fork terminals, which provides additional weight and material savings in fuse box designs by eliminating the need for female box terminals.

Time-Current Characteristics

% of Rating	Opening Time Min / Max (s)
110	360,000 s / -
135	0.750 s / 120 s
200	0.150 s / 5 s
350	0.080 s / 0.250 s
600	0.030 s / 0.100 s

Ratings

Part Number	Current Rating	Housing Color	Cold Resistance	I _t
0891005._	5 A	Orange	17.21	22
089107.5._	7.5 A	Brown	10.65	53
0891010._	10 A	Red	7.59	102
0891015._	15 A	Blue	4.70	198
0891020._	20 A	Yellow	3.35	420
0891025._	25 A	White	2.56	613
0891030._	30 A	Green	2.06	1110

Corresponding holder see Section "Fuse Holders."

LOW PROFILE MINI® FUSES RATED 58V

RoHS

Time-Current Characteristic Curves

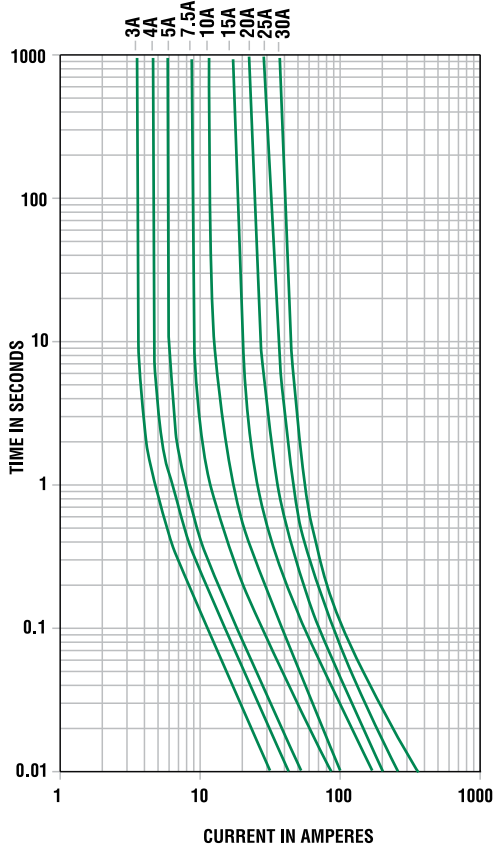

Temperature Derating Curve

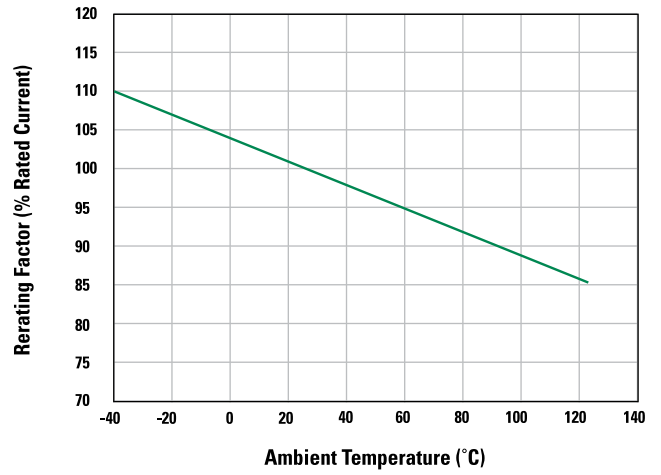

LOW PROFILE MINI® 10.9MM FUSES RATED 58V

RoHS



Specifications

Voltage Rating:	58 VDC
Interrupting Rating:	1000A @ 58 VDC
Operating Temperature Range:	-40°C to +125°C
Terminals:	Ag plated zinc
Housing Materials:	PA66

Ordering Information

Part Number	Package Size	Plating
0891xxx.NXWS	5000	Ag

Dimensions

Dimensions in mm

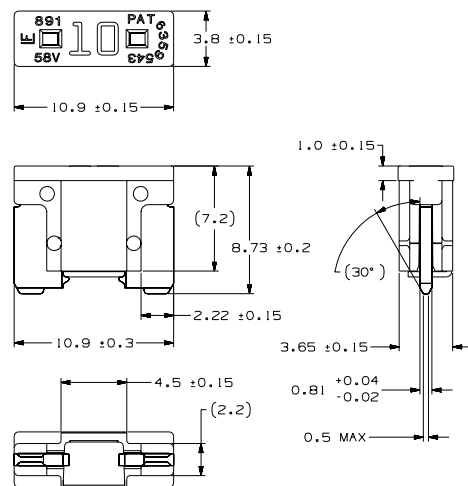

Description

The Low Profile MINI® fuse has similar performance characteristics as the standard MINI® fuse. The lower overall height allows for more space and weight savings. The Low Profile MINI® fuse is designed to mate with tuning-fork terminals, which provides additional weight and material savings in fuse box designs by eliminating the need for female box terminals.

Time-Current Characteristics

% of Rating	Opening Time Min / Max (s)
110	360,000 s / -
135	0.750 s / 120 s
200	0.150 s / 5 s
350	0.080 s / 0.250 s
600	0.030 s / 0.100 s

Ratings

Part Number	Current Rating	Housing Color	Cold Resistance	I _t
0891005_	5 A	Orange	17.21	22
089107.5_	7.5 A	Brown	10.65	53
0891010_	10 A	Red	7.59	102
0891015_	15 A	Blue	4.70	198
0891020_	20 A	Yellow	3.35	420
0891025_	25 A	White	2.56	613
0891030_	30 A	Green	2.06	1110

Corresponding holder see Section "Fuse Holders."

LOW PROFILE MINI® 10.9MM FUSES RATED 58V

RoHS

Time-Current Characteristic Curves

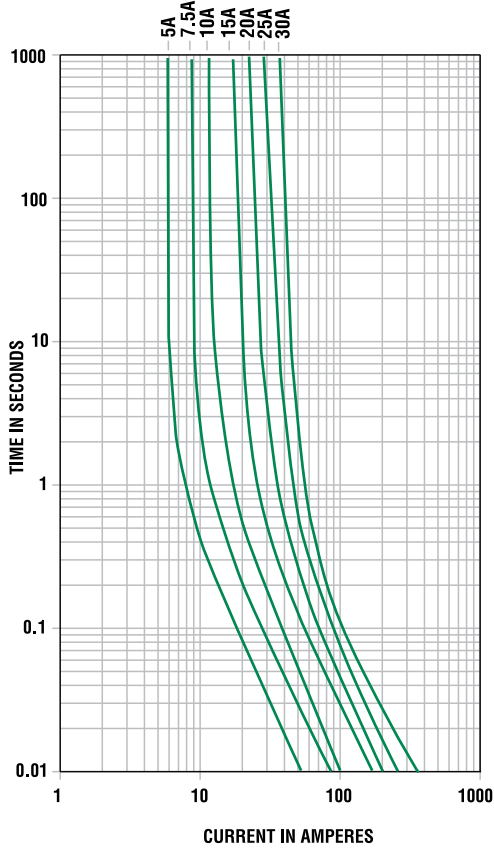

Temperature Derating Curve

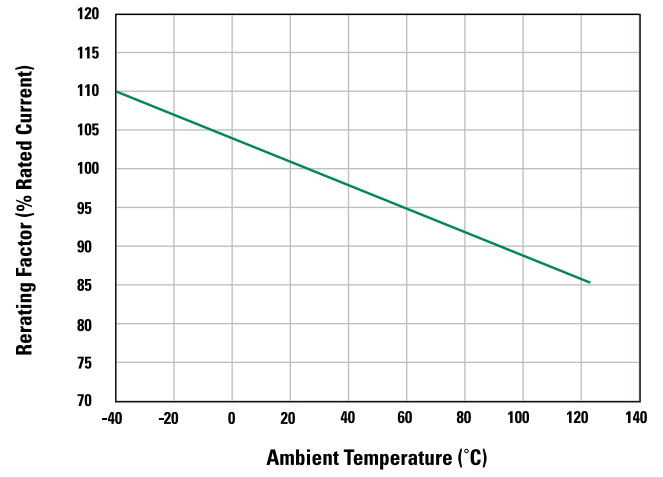

MINI[®] BLADE FUSE RATED 32V



Specifications

Interrupting Rating:	1000A @ 32 VDC
Voltage Rating:	32 VDC
Operating Temperature Range:	-40°C to +125°C
Terminals:	Ag plated zinc alloy
Housing Materials:	PA66
Complies with:	Meets SAE J2077 ISO 8820-3 UL 248 Special Purpose Fuses

Ordering Information

Part Number	Package Size
0297xxx.WXNV	3000
0297xxx.U	500
0297xxx.H	100
0297xxx.L	50

Description

The MINI[®] Fuse is quickly becoming the new standard for vehicle circuit protection. Its miniature design meets the need for more circuits to be protected while utilizing less space, and its ability to cope with high temperatures in adverse environments makes the MINI[®] Fuse the recommended choice for protection.

Time-Current Characteristics

% of Rating	Opening Time Min / Max (s)
110	360,000 s / -
135	0.75 s / 600 s
200	0.15 s / 5 s
350	0.080 s / 0.250 s
600	0.030 s / 0.100 s

Dimensions

Dimensions in mm

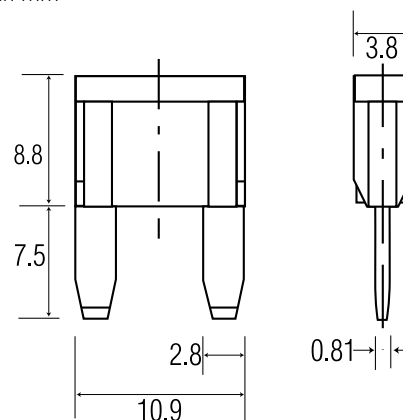

Ratings

Part Number	Current Rating	Housing Color	Typ. Voltage Drop	Cold Resistance	I ² t
0297002._	2 A	Grey	171 mV	55.60 mΩ	2.8 A ² s
0297003._	3 A	Purple	153 mV	33.75 mΩ	9.4 A ² s
0297004._	4 A	Pink	121 mV	23.48 mΩ	17 A ² s
0297005._	5 A	Orange	129 mV	17.75 mΩ	25 A ² s
029707.5_	7.5 A	Brown	135 mV	10.85 mΩ	68 A ² s
0297010._	10 A	Red	108 mV	7.42 mΩ	93 A ² s
0297015._	15 A	Blue	98 mV	4.58 mΩ	270 A ² s
0297020._	20 A	Yellow	96 mV	3.21 mΩ	380 A ² s
0297025._	25 A	White	86 mV	2.36 mΩ	625 A ² s
0297030._	30 A	Green	87 mV	1.85 mΩ	1130 A ² s

MINI[®] BLADE FUSE RATED 32V



Time-Current Characteristic Curves

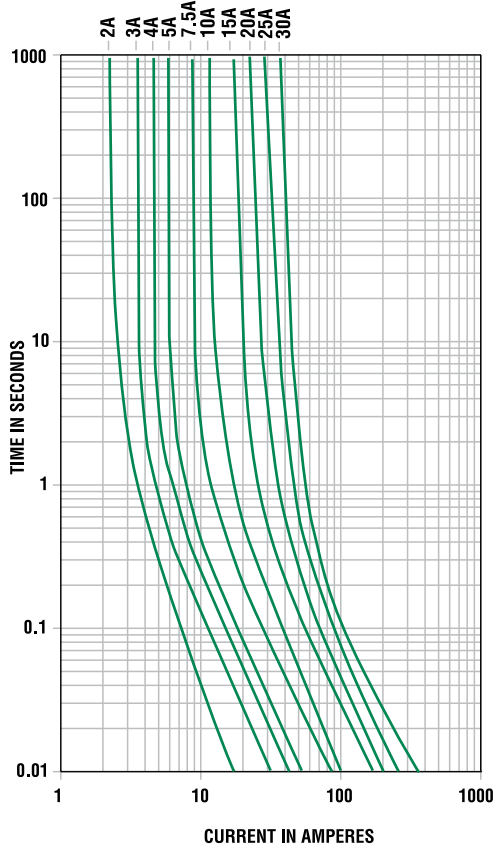

Temperature Derating Curve

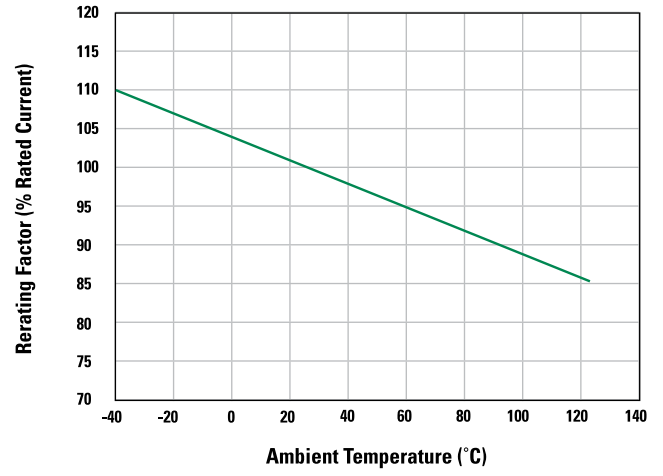

MINI[®] BLADE FUSE RATED 58V



Specifications

Interrupting Rating:	1000A @ 58 VDC
Voltage Rating:	58 VDC
Operating Temperature Range:	-40°C to +125°C
Terminals:	Ag plated zinc alloy
Housing Materials:	PA66
Complies with:	Meets SAE J2077 ISO 8820 UL 248 Special Purpose Fuses

Ordering Information

Part Number	Package Size
0997xxx.WXN	3000

Description

MINI[®] style fuse for use in 42V Systems. Same Time-Current characteristic as the 32V MINI[®] fuse. Fits into standard MINI[®] fuse sockets. Has a rejection feature to prevent fuses with lower voltage rating from being wrongfully inserted into the circuit. Current rating 2A - 30A @58 VDC max.

Time-Current Characteristics

% of Rating	Opening Time Min / Max (s)
110	360,000 s / -
135	0.75 s / 600 s
200	0.15 s / 5 s
350	0.080 s / 0.250 s
600	0.030 s / 0.100 s

Dimensions

Dimensions in mm

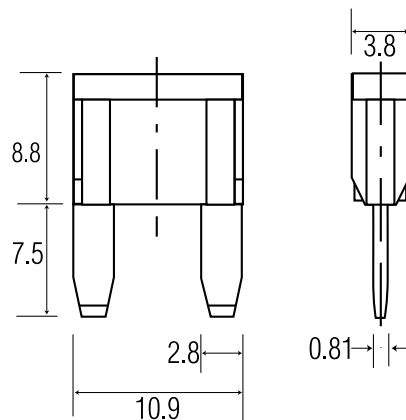

Ratings

Part Number	Current Rating	Housing Color	Typ. Voltage Drop	Cold Resistance	I ² t
0997002_	2 A	Grey	171 mV	55.60 mΩ	2.8 A ² s
0997003_	3 A	Purple	153 mV	33.75 mΩ	9.4 A ² s
0997004_	4 A	Pink	121 mV	23.48 mΩ	17 A ² s
0997005_	5 A	Brown	129 mV	17.75 mΩ	25 A ² s
099707.5_	7.5 A	Dark Brown	135 mV	10.85 mΩ	68 A ² s
0997010_	10 A	Red	108 mV	7.42 mΩ	93 A ² s
0997015_	15 A	Blue	98 mV	4.58 mΩ	270 A ² s
0997020_	20 A	Yellow	96 mV	3.21 mΩ	380 A ² s
0997025_	25 A	White	86 mV	2.36 mΩ	625 A ² s
0997030_	30 A	Green	87 mV	1.85 mΩ	1130 A ² s

MINI[®] BLADE FUSE RATED 58V



Time-Current Characteristic Curves

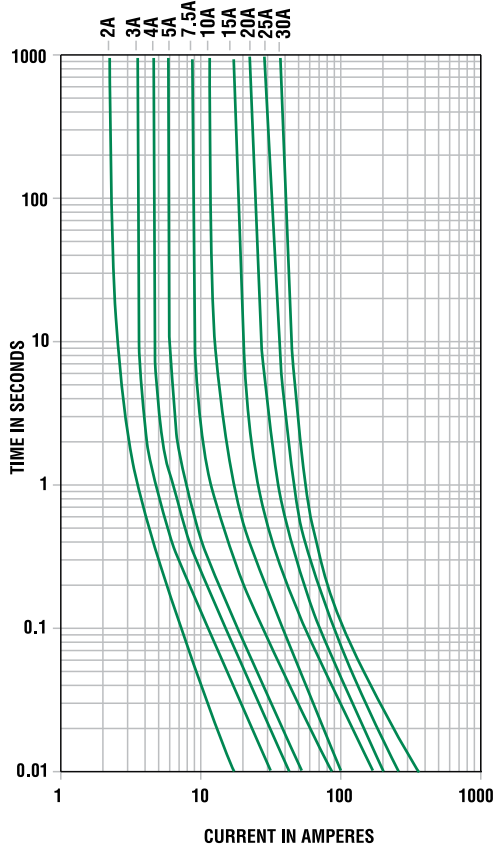

Temperature Derating Curve

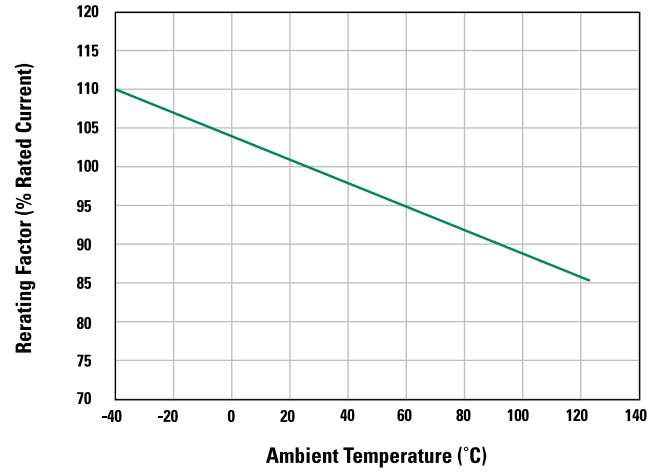

ATOF® BLADE FUSE RATED 32V



Description

Developed by Littelfuse for the automotive industry, the ATOF® fuse has become the original equipment circuit protection standard for foreign and domestic automobiles and trucks. Readily identifiable and easily replaced, this fuse can be specified for a variety of low voltage electronic applications.

Specifications

Voltage Rating:	32 VDC
Interrupting Rating:	1000A @ 32 VDC
Operating Temperature Range:	-40°C to +105°C
Terminals:	Sn plated zinc alloy
Housing Material:	PA66
Complies with:	ISO 8820-3 UL 248 Special Purpose Fuse

Ordering Information

Part Number	Package Size
0287xxx.PXCN	2000
0287xxx.U	500
0287xxx.H	100
0287xxx.L	50

Time-Current Characteristics

% of Rating	Opening Time	Opening Time Min / Max (s)
100	35-40	360,000 s / -
110	1-30	360,000 s / -
135	1-2 3-40	350 ms / 600 s 0.750 s / 600 s
160	1-40	250 ms / 50 s
200	1-2 3-40	100 ms / 5.0 s 0.150 s / 5.0 s
350	1-2 3-40	20 ms / 500 ms 80 ms / 500 ms
600	1-30 35-40	- / 100 ms - / 150 ms

Ratings

Part Number	Current Rating	Housing Color	Typ. Voltage Drop	Cold Resistance	I ² t
0287001._	1 A	Black	176 mV	123 mΩ	0.4 A ² s
0287002._	2 A	Grey	141 mV	53.5 mΩ	1.4 A ² s
0287003._	3 A	Purple	137 mV	31.1 mΩ	7.4 A ² s
0287004._	4 A	Pink	136 mV	22.8 mΩ	14 A ² s
0287005._	5 A	Orange	128 mV	17.85 mΩ	26 A ² s
028707.5_	7.5 A	Brown	116 mV	10.91 mΩ	60 A ² s
0287010._	10 A	Red	109 mV	7.70 mΩ	115 A ² s
0287015._	15 A	Blue	102 mV	4.80 mΩ	340 A ² s
0287020._	20 A	Yellow	98 mV	3.38 mΩ	520 A ² s
0287025._	25 A	White	92 mV	2.52 mΩ	1080 A ² s
0287030._	30 A	Green	84 mV	1.97 mΩ	1510 A ² s
0287035._	35 A	Dark Green	87 mV	1.61 mΩ	2280 A ² s
0287040._	40 A	Orange	96 mV	1.44 mΩ	3310 A ² s

Corresponding holder see Section "Fuse Holders."

ATOF® BLADE FUSE RATED 32V



Dimensions

Dimensions in mm

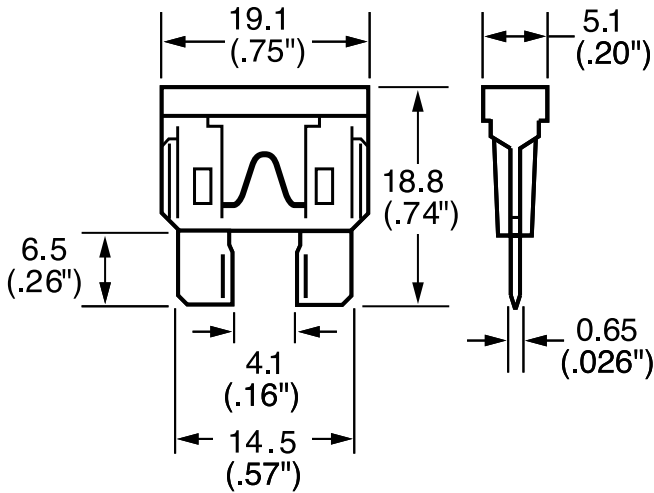

Temperature Derating Curve

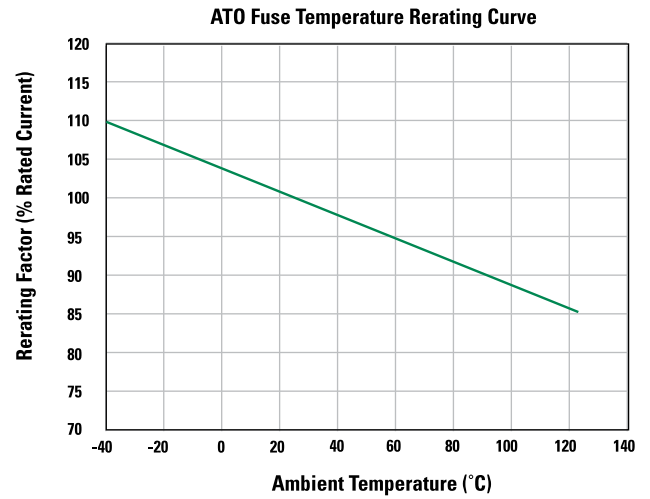

Time-Current Characteristic Curves

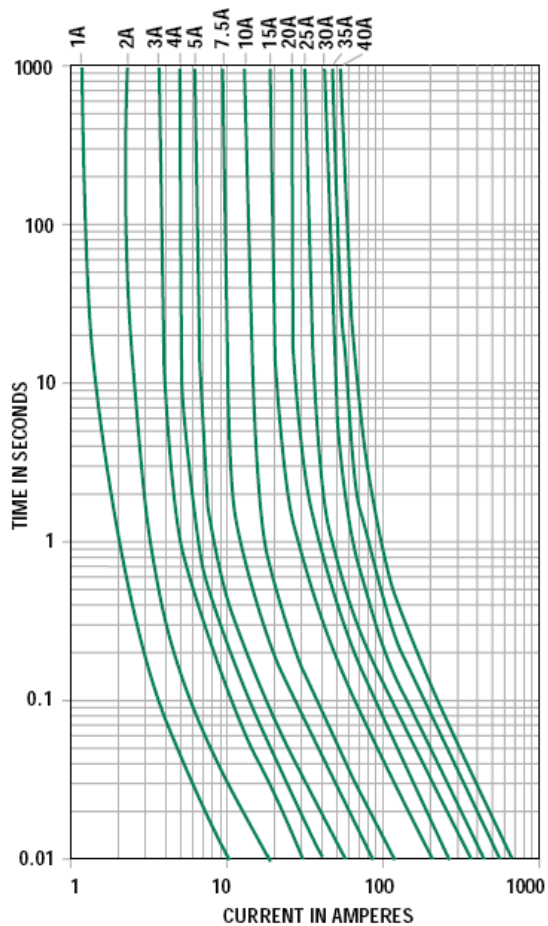

ATO SILVER™ FUSE RATED 32V



Specifications

Voltage Rating:	32 VDC
Interrupting Rating:	1000A @ 32 VDC
Operating Temperature Range:	-40°C to +125°C
Terminals:	Ag plated zinc alloy
Housing Material:	PA66
Complies with:	ISO 8820 - 3 UL 248 Special Purpose Fuse

Ordering Information

Part Number	Package Size
0287xxx.PXS	2000

Description

Developed by Littelfuse for the automotive industry, the ATO SILVER™ fuse has become the original equipment circuit protection standard for foreign and domestic automobiles and trucks. Readily identifiable and easily replaced, this fuse can be specified for a variety of low voltage electronic applications.

Time-Current Characteristics

% of Rating	Current Rating	Opening Time Min / Max (s)
100	35-40	360,000 s / -
110	1-30	360,000 s / -
135	1-2 3-40	350 ms / 600 s 750 ms / 600 s
160	1-40	250 ms / 50s
200	1-2 3-40	100 ms / 5.0 s 150 ms / 5.0 s
350	1-2 3-40	20 ms / 500 ms 80 ms / 500 ms
600	1-30 35-40	- / 100 ms - / 150 ms

Ratings

Part Number	Current Rating	Housing Color	Typ. Voltage Drop	Cold Resistance	I ² t
0287001._	1 A	Black	159 mV	121.1 mΩ	0.4 A ² s
0287002._	2 A	Grey	158 mV	54.5 mΩ	1.4 A ² s
0287003._	3 A	Purple	134 mV	30.5 mΩ	7.4 A ² s
0287004._	4 A	Pink	130 mV	21.9 mΩ	14 A ² s
0287005._	5 A	Brown	130 mV	17.2 mΩ	26 A ² s
028707.5_	7.5 A	Dark Brown	123 mV	10.9 mΩ	60 A ² s
0287010._	10 A	Red	113 mV	7.6 mΩ	115 A ² s
0287015._	15 A	Blue	106 mV	4.7 mΩ	340 A ² s
0287020._	20 A	Yellow	104 mV	3.4 mΩ	520 A ² s
0287025._	25 A	White	100 mV	2.5 mΩ	1080 A ² s
0287030._	30 A	Green	95 mV	2.0 mΩ	1510 A ² s
0287035._	35 A	Dark Green	93 mV	1.6 mΩ	2280 A ² s
0287040._	40 A	Orange	91 mV	1.4 mΩ	3310 A ² s

Corresponding holder see Section "Fuse Holders."

ATO SILVER™ FUSE RATED 32V



Dimensions

Dimensions in mm

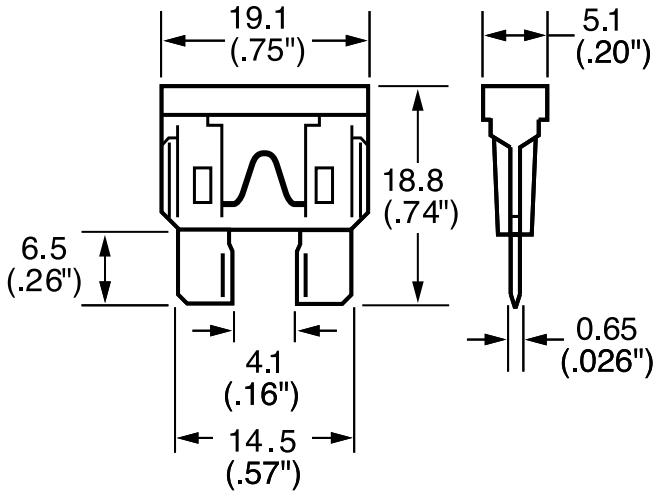

Temperature Derating Curve

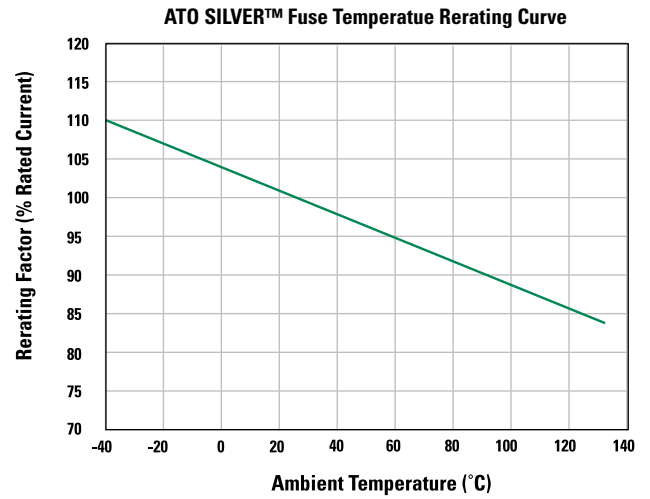

Time-Current Characteristic Curves

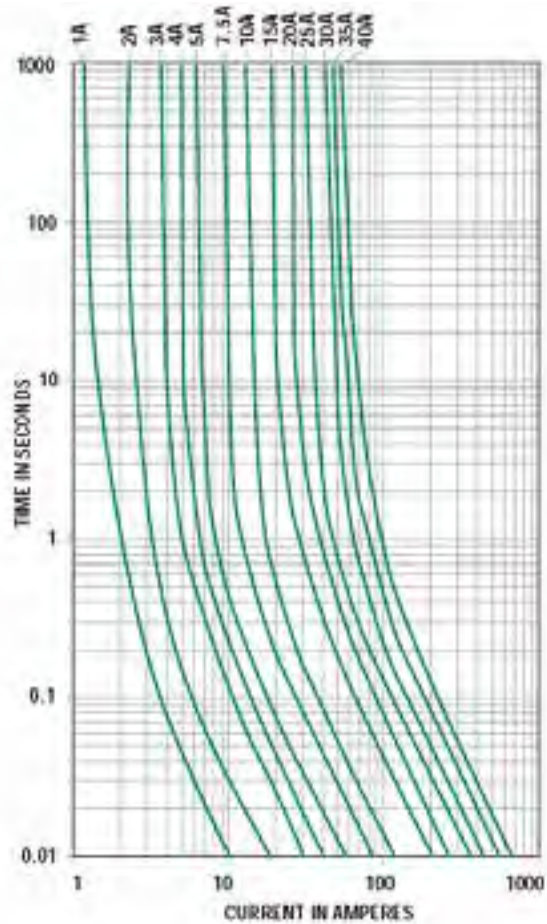

MAXI® BLADE FUSE RATED 32V



Specifications

Voltage Rating:	32 VDC
Interrupting Ratings:	1000A @ 32 VDC
Operating Temperature Range:	-40°C to +125°C
Terminals:	Ag plated zinc alloy
Housing Material:	PA66
Complies with:	SAE J 1888 ISO 8820-3:2002(E)

Ordering Information

Part Number	Package Size
0299xxx.ZXNV	1200
0299xxx.L	50
0299xxx.TXN	10

Description

The MAXI® fuse uses "Diffusion Pill Technology" to provide predictable time delay characteristic and low heat dissipation.

Dimensions

Dimensions in mm

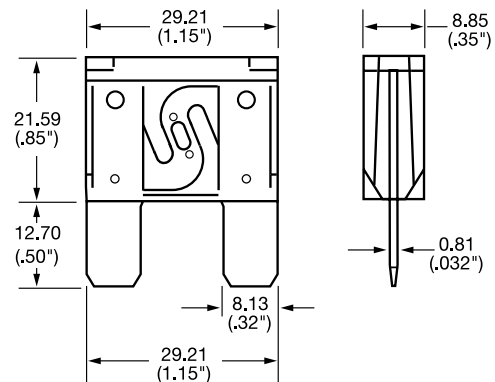

Time-Current Characteristics

% of Rating	Opening Time Min / Max (s)
100	360,000 s / -
135	60 s / 1,800 s
200	2 s / 60 s
350	0.20 s / 7 s
600	0.040 s / 1 s

Ratings

Part Number	Current Rating	Housing Color	Typ. Voltage Drop	Cold Resistance	I ² t
0299020_	20 A	Yellow	76 mV	3.10 mΩ	1100 A ² s
0299025_	25 A	Grey	75 mV	2.39 mΩ	2087 A ² s
0299030_	30 A	Green	77 mV	1.95 mΩ	4070 A ² s
0299035_	35 A	Brown	75 mV	1.71 mΩ	6032 A ² s
0299040_	40 A	Orange	75 mV	1.42 mΩ	8450 A ² s
0299050_	50 A	Red	73 mV	1.10 mΩ	11300 A ² s
0299060_	60 A	Blue	77 mV	0.89 mΩ	15300 A ² s
0299070_	70 A	Tan	61 mV	0.64 mΩ	6900 A ² s
0299080_	80 A	White	62 mV	0.54 mΩ	8800 A ² s

Corresponding holder see Section "Fuse Holders."

MAXI[®] BLADE FUSE RATED 32V

RoHS

Temperature Derating Curve

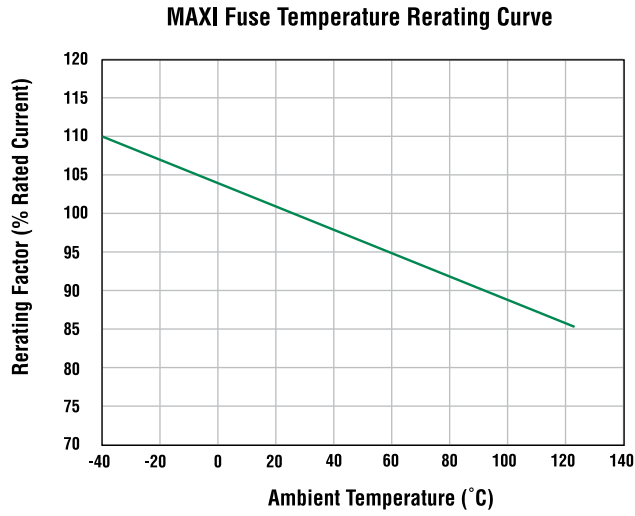

Time-Current Characteristic Curves

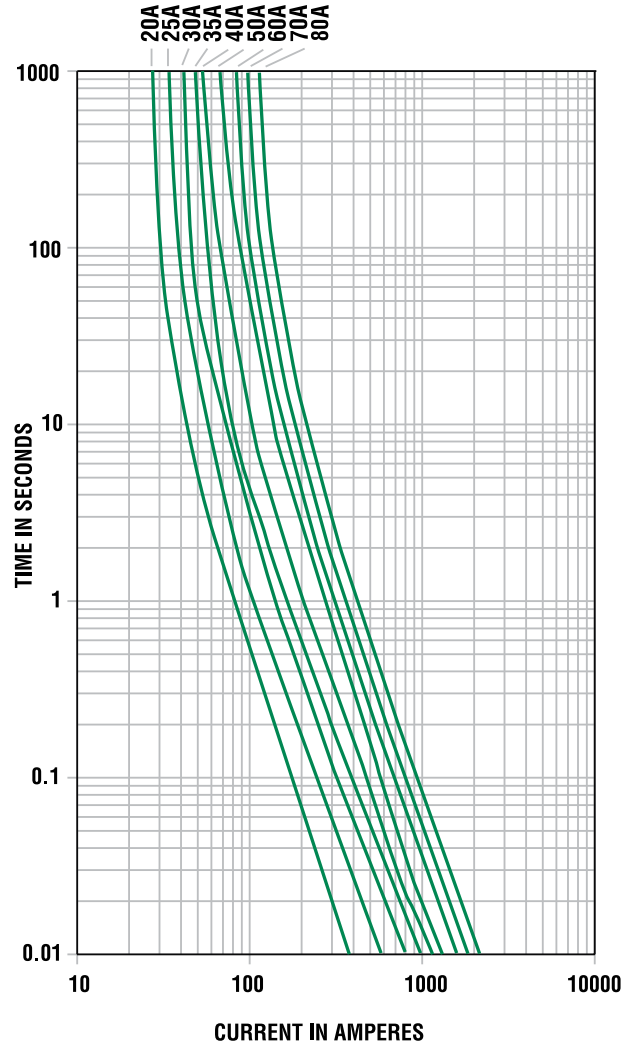

MAXI[®] BLADE FUSE RATED 58V

RoHS



Specifications

Voltage Rating:	58 VDC
Interrupting Ratings:	1000A @ 58 VDC
Operating Temperature Range:	-40°C to +125°C
Terminals:	Ag plated zinc alloy
Housing Material:	PA66
Complies with:	SAE J 1888 ISO 8820-3:2002(E)

Ordering Information

Part Number	Package Size
0999xxx.ZXN	1200

Description

The MAXI[®] fuse uses “Diffusion Pill Technology” to provide predictable time delay characteristic and low heat dissipation.

Time-Current Characteristics

% of Rating	Opening Time Min / Max (s)
100	360,000 s / -
135	60 s / 1,800 s
200	2 s / 60 s
350	0.20 s / 7 s
600	0.040 s / 1 s

Dimensions

Dimensions in mm

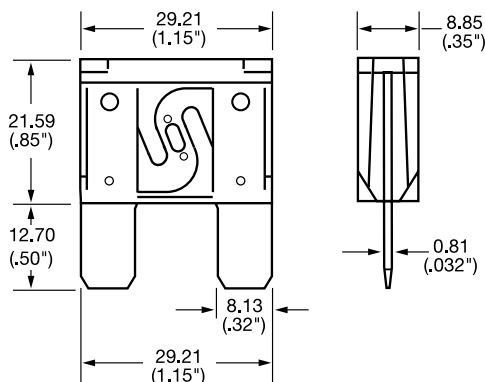

Ratings

Part Number	Current Rating	Housing Color	Typ. Voltage Drop	Cold Resistance	I ² t
0999020_	20 A	Yellow	76 mV	3.10 mΩ	1100 A ² s
0999025_	25 A	Grey	75 mV	2.39 mΩ	2087 A ² s
0999030_	30 A	Green	77 mV	1.95 mΩ	4070 A ² s
0999035_	35 A	Brown	75 mV	1.71 mΩ	6032 A ² s
0999040_	40 A	Orange	75 mV	1.42 mΩ	8450 A ² s
0999050_	50 A	Red	73 mV	1.10 mΩ	11300 A ² s
0999060_	60 A	Blue	77 mV	0.89 mΩ	15300 A ² s
0999070_	70 A	Tan	61 mV	0.64 mΩ	6900 A ² s
0999080_	80 A	White	62 mV	0.54 mΩ	8800 A ² s

Corresponding holder see Section “Fuse Holders.”

MAXI[®] BLADE FUSE RATED 58V

RoHS

Temperature Derating Curve

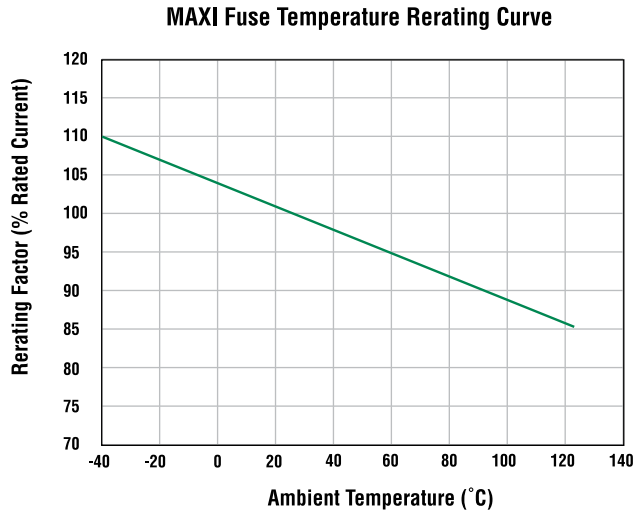

Time-Current Characteristic Curves

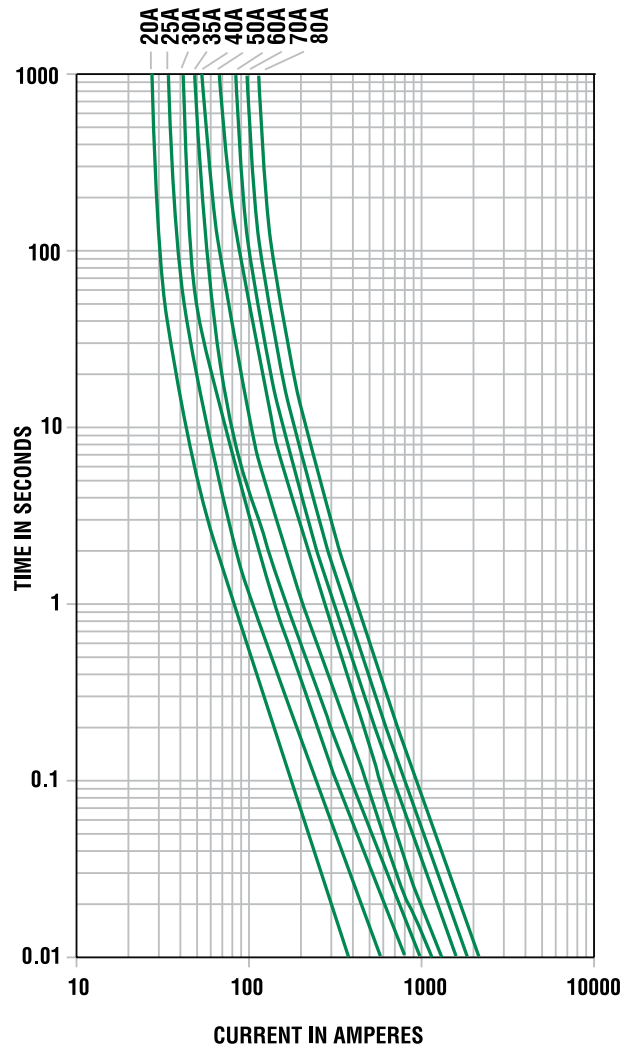

FK1 MINI® STYLE BLADE FUSE RATED 32V



Specifications

Insulating Body:	Out of thermoplastic (UL 94-V0, heat-resistant)
Interrupting Rating:	1000 A @32 VDC
Cover:	Out of thermoplastic (V0, transparent) Visible melting-element Shunt: Red, not transparent
Terminals:	Blade contacts Copper alloy, gal. Sn plated Edge-protected
Complies with:	ISO 8820-3:2002(E) UL 248 Special Purpose Fuses
cULus Recognized:	File No. E10480

Ordering Information

Part Number	Package Size
168.6785.xxx2	8000
168.6785.xxx7	50

Description

The FK1 32V automotive standard fuse link in a MINI® package. Three part construction with copper contacts for excellent reliability in harsh environment conditions with low voltage drop. Current ratings 1A thru 30A. See-through cover for easy detection of blown fuses.

Time-Current Characteristics

% of Rating	Opening Time Min / Max (s)
110	360,000 s / -
135	0.75 s / 1,800 s
200	0.15 s / 5 s
350	0.040 s / 0.500 s
600	0.020 s / 0.100 s

Ratings

Part Number	Current Rating	Housing Color	Typ. Voltage Drop	Cold Resistance	I²t
168.6785.410_	1 A	Black	135 mV	100 mΩ	0.83 A²s
168.6785.420_	2 A	Grey	110 mV	43.0 mΩ	3.31 A²s
168.6785.430_	3 A	Purple	110 mV	27.0 mΩ	7.45 A²s
168.6785.440_	4 A	Pink	110 mV	21.3 mΩ	16.7 A²s
168.6785.450_	5 A	Brown	105 mV	16.2 mΩ	19.8 A²s
168.6785.475_	7.5 A	Dark Brown	100 mV	9.70 mΩ	44.5 A²s
168.6785.510_	10 A	Red	110 mV	7.40 mΩ	79.2 A²s
168.6785.515_	15 A	Blue	105 mV	4.50 mΩ	178 A²s
168.6785.520_	20 A*	Yellow	100 mV	3.10 mΩ	331 A²s
168.6785.525_	25 A*	White	120 mV	2.60 mΩ	653 A²s
168.6785.530_	30 A*	Green	105 mV	1.95 mΩ	1,264 A²s
160.6785.000_	Shunt*	White	60 mV	1.35 mΩ	1,800 A²s

* Not mentioned in the standards
Corresponding holder see Section "Fuse Holders."

FK1 MINI® STYLE BLADE FUSE RATED 32V



Dimensions

Dimensions in mm

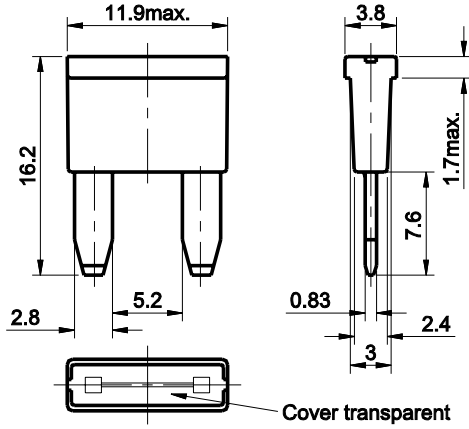

Pre-Arcing Time-Limits

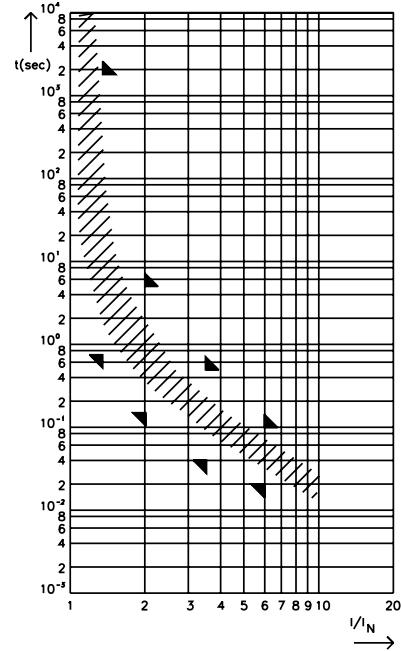

FI = 1.33 (max. operating current: 0.75 × I_{rat} at 23°C)

FUN MINI® STYLE BLADE FUSE RATED 125V

RoHS



Specifications

Insulating Body:	Out of thermoplastic (UL 94-V0, heat-resistant)
Cover:	Out of thermoplastic V0 Red, not transparent
Terminals:	Blade contacts Copper alloy, gal. Sn plated Edge-protected
Interrupting Rating:	1000 A @125 VDC

Ordering Information

Part Number	Package Size
125.6785.xxx2	1000
125.6785.xxx7	50

Dimensions

Dimensions in mm

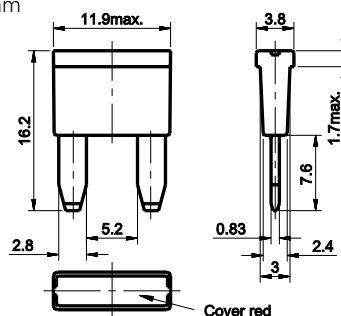

Description

The FUN is a 125V rated MINI® style fuse. It features a three part construction with copper contacts for excellent reliability in harsh environment conditions and low voltage drop. Current ratings 3A thru 15A. Filled with arc-quenching material.

Pre-Arcing Time-Limits

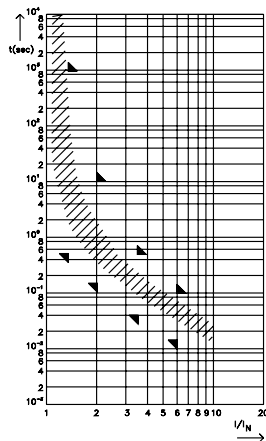

FI = 1.43 (max. operating current :
0.7 x I_{rat} at 23°C)

Ratings

Part Number	Current Rating	Housing Color	Typ. Voltage Drop	Cold Resistance	I ² t
125.6785.430_	3 A		130 mV	35.0 mΩ	8.50 A ² s
125.6785.440_	4 A		120 mV	23.5 mΩ	14.5 A ² s
125.6785.450_	5 A		120 mV	18.0 mΩ	25.0 A ² s
125.6785.475_	7.5 A		110 mV	11.0 mΩ	60.0 A ² s
125.6785.510_	10 A		110 mV	8.00 mΩ	85.0 A ² s
125.6785.515_	15 A		110 mV	5.00 mΩ	155 A ² s

Corresponding holder see Section "Fuse Holders."

Time-Current Characteristics

% of Rating	Opening Time Min / Max (s)
110	360,000 s / -
150	0.500 s / 900 s
200	0.150 s / 10 s
350	0.040 s / 0.500 s
600	0.015 s / 0.100 s

FP1 MINI® STYLE PCB FUSE RATED 32V



Specifications

Insulating body:	Out of thermoplastic (UL 94-V0, heat-resistant)
Cover:	Out of thermoplastic (V0, transparent), Visible melting-element
Terminals:	Shunt: Red, not transparent Soldering pins Copper alloy, gal. Sn plated
Interrupting Rating:	1000 A @ 32 VDC
Complies with:	UL 248 Special Purpose Fuses
cULus Recognized:	File No. E10480

Ordering Information

Part Number	Package Size
168.6585.xxx2	1500
168.6585.xxx6	100

Description

The FP1 is a MINI® style fuse for direct trough-hole pcb soldering. The FP1 has similar performance characteristics as the standard FK1 fuse.

Time-Current Characteristics

% of Rating	Opening Time Min / Max (s)
110	360,000 s / -
135	0.750 s / 1,800 s
200	0.150 s / 5 s
350	0.040 s / 0.500 s
600	0.020 s / 0.100 s

Ratings

Part Number	Current Rating	Housing Color	Typ. Voltage Drop Littelfuse max.	Cold Resistance	I ² t
168.6585.410_	1 A	Black	135 mV	100 mΩ	0.83 A ² s
168.6585.420_	2 A	Grey	110 mV	43.0 mΩ	3.31 A ² s
168.6585.430_	3 A	Purple	110 mV	27.0 mΩ	7.45 A ² s
168.6585.440_	4 A	Pink	110 mV	21.3 mΩ	16.7 A ² s
168.6585.450_	5 A	Orange	105 mV	16.2 mΩ	19.8 A ² s
168.6585.475_	7.5 A	Brown	100 mV	9.70 mΩ	44.5 A ² s
168.6585.510_	10 A	Red	110 mV	7.40 mΩ	79.2 A ² s
168.6585.515_	15 A	Blue	105 mV	4.50 mΩ	178 A ² s
168.6585.520_	20 A*	Yellow	100 mV	3.10 mΩ	331 A ² s
168.6585.525_	25 A*	White	105 mV	2.60 mΩ	653 A ² s
168.6585.530_	30 A*	Green	105 mV	1.90 mΩ	1,264 A ² s
160.6585.0002	Shunt*	White	60 mV	1.35 mΩ	1,800 A ² s

*Not mentioned in the standards

FP1 MINI® STYLE PCB FUSE RATED 32V

Dimensions

Dimensions in mm

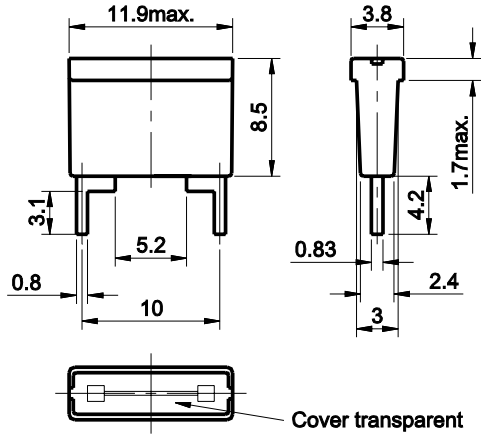

Pre-Arcing Time-Limits

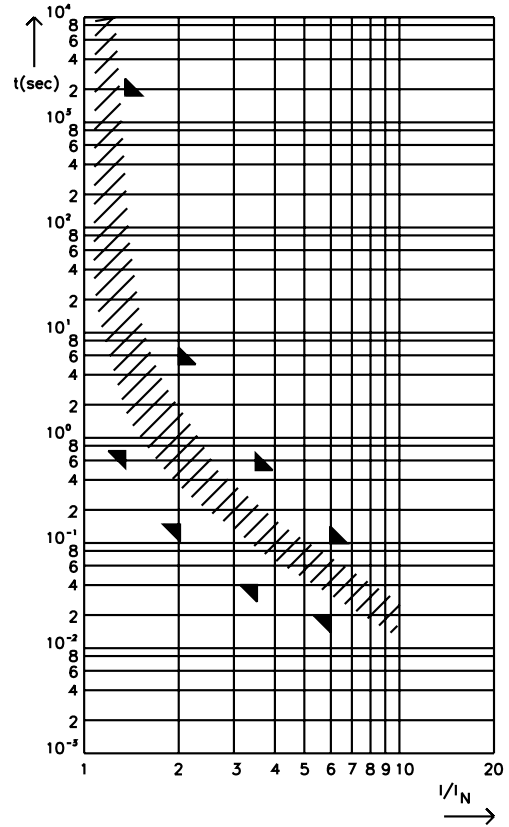

FI = 1.33 (max. operating current: $0.75 \times I_{\text{rat}}$ at 23°C)

FKS ATO® STYLE BLADE FUSE RATED 32V



Description

The FKS-32 is an ATO® style blade fuse rated at 32V, featuring a three part construction with copper contacts for excellent reliability in harsh environment conditions and low voltage drop. Current ratings 1A thru 40A. With see-through cover for easy detection of blown fuses.

Ratings

Part Number	Current Rating	Housing Color	Typ. Voltage Drop Littelfuse max.	Cold Resistance	I ² t
162.6185.410_	1 A*	Black	150 mV	108 mΩ	2.00 A ² s
162.6185.420_	2 A*	Grey	130 mV	47.2 mΩ	8.00 A ² s
162.6185.430_	3 A	Purple	140 mV	30.5 mΩ	15.0 A ² s
162.6185.440_	4 A	Pink	120 mV	22.5 mΩ	25.0 A ² s
164.6185.450_	5 A	Brown	145 mV	16.5 mΩ	35.0 A ² s
164.6185.475_	7.5 A	Dark Brown	115 mV	11.5 mΩ	60.0 A ² s
164.6185.510_	10 A	Red	95 mV	6.80 mΩ	110 A ² s
164.6185.515_	15 A	Blue	90 mV	4.50 mΩ	250 A ² s
164.6185.520_	20 A	Yellow	90 mV	3.40 mΩ	648 A ² s
164.6185.525_	25 A	White	80 mV	2.50 mΩ	600 A ² s
164.6185.530_	30 A	Green	80 mV	1.85 mΩ	1,070 A ² s
162.6185.535_	35 A	Dark Green	75 mV	1.50 mΩ	1,600 A ² s
162.6185.540_	40 A	Orange	100 mV	1.35 mΩ	2,000 A ² s
160.6185.000_	Shunt*	White	42 mV	0.73 mΩ	9,000 A ² s

* Not mentioned in the standards
Corresponding holder see Section "Fuse Holders."

Specifications

Interrupting Rating:	1000 A @32 VDC
Insulating Body:	Out of thermoplastic (UL 94-V0, heat-resistant)
Cover:	Out of thermoplastic (V0, transparent), Visible melting-element Shunt: red, not transparent
Terminals:	Blade contacts Copper alloy, gal. Sn plated Edge-protected
Complies with:	ISO 8820-3:2002(E) UL 248 Supplemental Fuses
cULus Recognized:	File No. E10480

Ordering Information

Part Number	Package Size
164.6185.xxx2	2000
162.6185.xxx2	2000
162.6185.xxx6	100

Time-Current Characteristics

% of Rating	Opening Time Min / Max (s)
110	360,000 s / -
135	0.750 s / 1,800 s
200	0.150 s / 5 s
350	0.040 s / 0.500 s
600	0.020 s / 0.100 s

FKS ATO® STYLE BLADE FUSE RATED 32V



Dimensions

Dimensions in mm

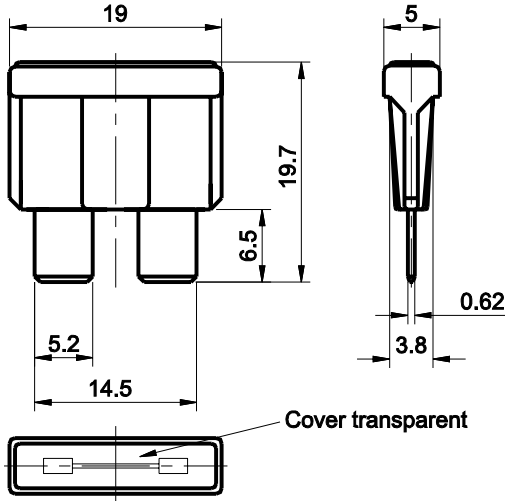

Pre-Arcing Time-Limits

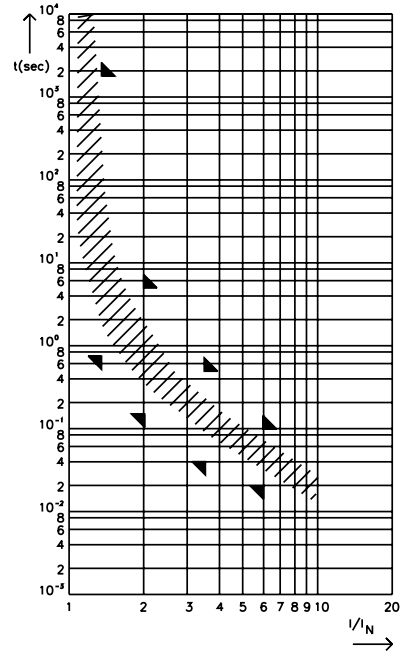

FI = 1.33 (max. operating current: $0.75 \times I_{rat}$ at 23°C)

TAC ATO® STYLE BLADE FUSE RATED 58V



Description

The TAC is an ATO® style blade fuse rated at 58V, featuring a three part construction with copper contacts for excellent reliability in harsh environment conditions and low voltage drop. Current ratings 1A thru 40A. With see-through cover for easy detection of blown fuses.

Specifications

Interrupting Rating:	1000 A @ 58 VDC
Insulating Body:	Out of thermoplastic (UL 94-V0, heat-resistant)
Cover:	Out of thermoplastic (V0, transparent), Visible melting-element
Terminals:	Blade contacts Copper alloy, gal. Sn plated Edge-protected
Complies with:	ISO 8820-3:2002(E) UL 248 Special Purpose Fuses
cULus Recognized:	File No. E10480

Ordering Information

Part Number	Package Size
142.6185.xxx.2	2000
142.6185.xxx.6	100

Time-Current Characteristics

% of Rating	Opening Time Min / Max (s)
110	360,000 s / –
135	0.750 s / 1,800 s
200	0.150 s / 5 s
350	0.040 s / 0.500 s
600	0.020 s / 0.100 s

Ratings

Part Number	Current Rating	Housing Color	Typ. Voltage Drop Littelfuse max.	Cold Resistance	I ² t
142.6185.410_	1 A*	Black	150 mV	108 mΩ	2.00 A ² s
142.6185.420_	2 A*	Grey	130 mV	45.0 mΩ	8.00 A ² s
142.6185.430_	3 A	Purple	140 mV	28.5 mΩ	15.0 A ² s
142.6185.440_	4 A	Pink	120 mV	22.5 mΩ	25.0 A ² s
142.6185.450_	5 A	Brown	145 mV	16.5 mΩ	35.0 A ² s
142.6185.475_	7.5 A	Dark Brown	115 mV	11.5 mΩ	60.0 A ² s
142.6185.510_	10 A	Red	95 mV	6.80 mΩ	115 A ² s
142.6185.515_	15 A	Blue	90 mV	4.30 mΩ	250 A ² s
142.6185.520_	20 A	Yellow	90 mV	3.10 mΩ	600 A ² s
142.6185.525_	25 A	White	80 mV	2.30 mΩ	600 A ² s
142.6185.530_	30 A	Green	80 mV	1.90 mΩ	1,070 A ² s
142.6185.540_	40 A	Orange	100 mV	1.40 mΩ	2,000 A ² s

* Not mentioned in the standards
Corresponding holder see Section "Fuse Holders."

TAC ATO® STYLE BLADE FUSE RATED 58V



Dimensions

Dimensions in mm

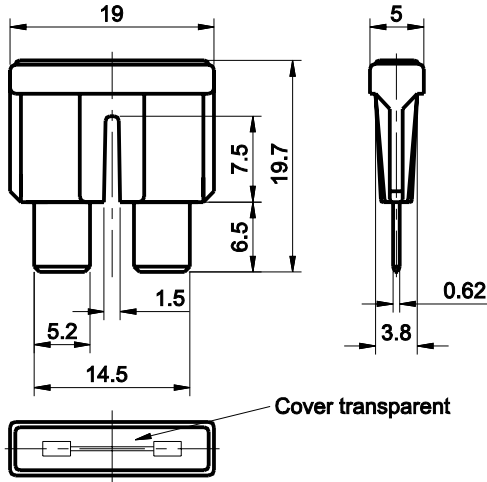

Pre-Arcing Time-Limits

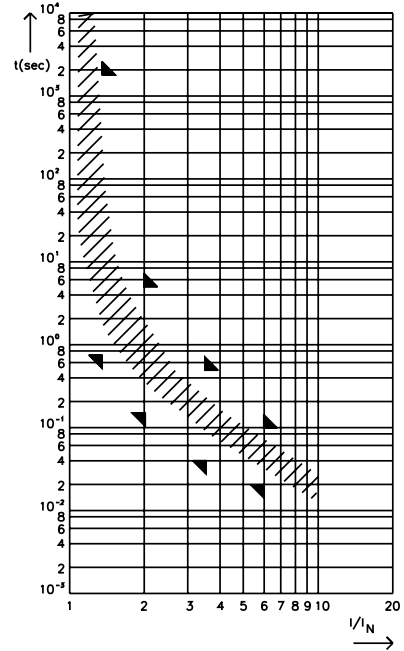

FI = 1.33 (max. operating current: $0.75 \times I_{\text{rat}}$ at 23°C)

FKS ATO® STYLE BLADE FUSE RATED 80V



Specifications

Interrupting Rating:	1000 A @ 80 VDC
Insulating Body:	Out of thermoplastic (UL 94-V0, heat-resistant)
Cover:	Out of thermoplastic (UL 94-V0, heat-resistant) Red, not transparent
Terminals:	Blade contacts Copper alloy, gal. Sn plated Edge-protected
Complies with:	UL 248 Special Purpose Fuses
cULus Recognized:	File No. E10480

Ordering Information

Part Number	Package Size
166.7000.xxx2	500
166.7000.xxx6	100









Description

The FKS-80 is an ATO® style blade fuse rated at 80V, featuring a three part construction with copper contacts for excellent reliability in harsh environment conditions and low voltage drop. Current ratings 3A thru 30A. Filled with arc-quenching material.

Time-Current Characteristics

% of Rating	Opening Time Min / Max (s)
110	360,000 s / -
150	0.500 s / 300 s
200	0.150 s / 20 s
350	0.040 s / 0.500 s
600	0.020 s / 0.100 s

Ratings

Part Number	Current Rating	Housing Color	Typ. Voltage Drop	Cold Resistance	I ² t
166.7000.430_	3 A		145 mV	39.0 mΩ	8.10 A ² s
166.7000.440_	4 A		140 mV	29.0 mΩ	14.4 A ² s
166.7000.450_	5 A		140 mV	20.6 mΩ	24.3 A ² s
166.7000.475_	7.5 A		120 mV	11.5 mΩ	44.5 A ² s
166.7000.510_	10 A		110 mV	7.90 mΩ	86.4 A ² s
166.7000.515_	15 A		110 mV	4.60 mΩ	162 A ² s
166.7000.520_	20 A		110 mV	3.30 mΩ	475 A ² s
166.7000.525_	25 A		105 mV	2.27 mΩ	950 A ² s
166.7000.530_	30 A		100 mV	1.79 mΩ	1,500 A ² s

Corresponding holder see Section "Fuse Holders."

FKS ATO® STYLE BLADE FUSE RATED 80V



Dimensions

Dimensions in mm

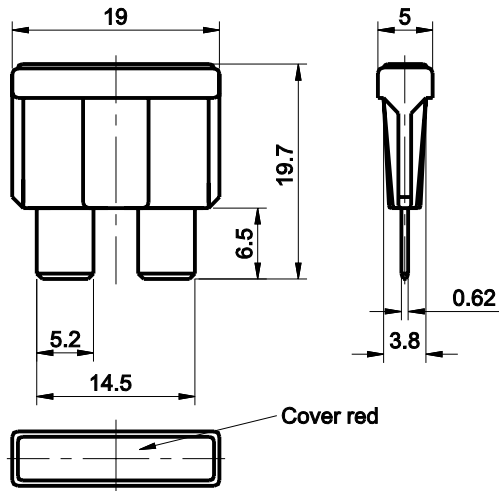

Pre-Arcing Time-Limits

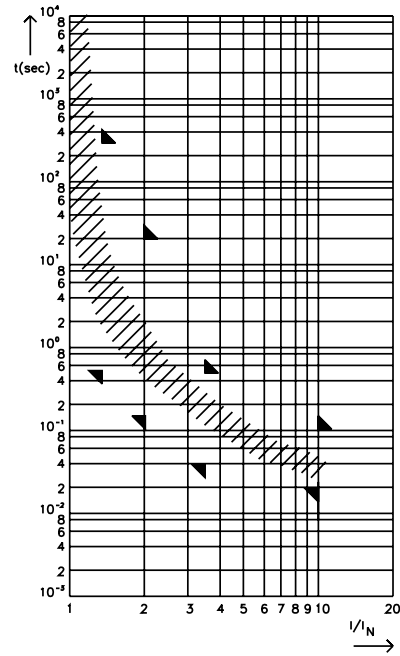

FI = 1.43 (max. operating current: $0.7 \times I_{\text{rat}}$ at 23°C)

TF ATO® STYLE BLADE FUSE RATED 90V

RoHS



Description

The TF is an ATO® style blade fuse rated at 90V, featuring a three part construction with copper contacts for excellent reliability in harsh environment conditions and low voltage drop. With see-through cover for easy detection of blown fuses. The fuses were defined over the I²t value, not via t/c curve requirements.

Dimensions

Dimensions in mm

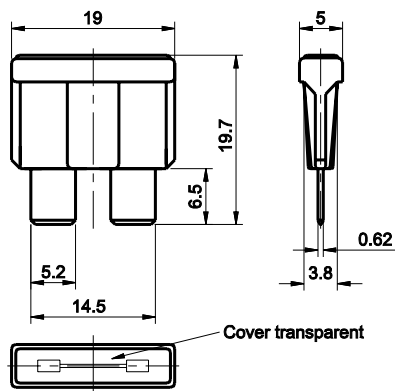

Ratings

Part Number	Current Rating	Housing Color	Typ. Voltage Drop	Cold Resistance	I ² t
162.7049.4402	4 A		115 mV	19.4 Ω	> 100 A ² s
162.7049.4802	8 A		80 mV	7.50 Ω	> 300 A ² s
162.7049.5102	10 A		70 mV	6.10 Ω	> 580 A ² s
162.7049.5152	15 A		65 mV	3.50 Ω	> 1,700 A ² s

Remark: TF-fuse links are back-up fuse links, see minimum fault current. Corresponding holder see Section "Fuse Holders."

Specifications

Insulating Body:	Out of thermoplastic (UL 94-V0, heat-resistant)
Cover:	Out of thermoplastic (UL 94-V0, heat-resistant)
	Visible melting element
Terminals:	Blade contacts
	Copper alloy, gal. Sn
	Edge-protected
Test cable:	4 mm ²

Ordering Information

Part Number	Package Size
162.7049.xxx2	2000

Time-Current Characteristics

% of Rating	Opening Time Min / Max (s)
110	14,400 s / -
200 (4A & 8A only)	- / 300 s
300	- / 10 s
500	0.20 s / -

Pre-arcing Time-limits

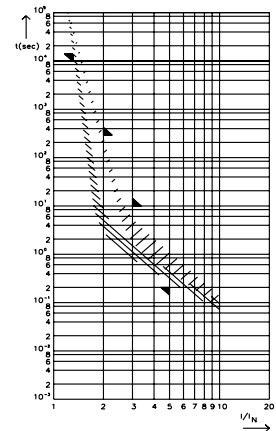

FK3 MAXI® STYLE BLADE FUSE RATED 32V

RoHS



Description

The FK3 32V automotive standard fuse link in MAXI® size. Three part construction with copper contacts for excellent reliability in harsh environment conditions with low voltage drop. Current ratings 20A thru 100A. With see-through cover for easy detection of blown fuses.

Specifications

Insulating Body:	Out of thermoplastic (UL 94-V0, heat-resistant)
Cover:	Out of thermoplastic (UL 94-V0, heat-resistant)
Terminals:	Blade contacts Copper alloy, gal. Sn Edge-protected
Interrupting Rating:	1000 A @32 VDC
Complies with:	SAE J 1888 ISO 8820-3:2002(E) UL 248 Special Purpose Fuses

Ordering Information

Part Number	Package Size
169.6885.xxx2	1000
169.6885.xxx1	10

Time-Current Characteristics

% of Rating	Opening Time Min / Max (s)
100	360,000 s / -
135	60 s / 1,800 s
200	2 s / 60 s
350	0.20 s / 7 s
600	0.040 s / 1 s

Ratings

Part Number	Current Rating	Housing Color	Typ. Voltage Drop Littelfuse max.	Cold Resistance	I ² t
169.6885.520_	20 A	Yellow	95 mV	3.80 mΩ	1,900 A ² s
169.6885.525_	25 A*	Grey	100 mV	2.80 mΩ	2,300 A ² s
169.6885.530_	30 A	Green	80 mV	2.10 mΩ	6,000 A ² s
169.6885.535_	35 A*	Dark Green	100 mV	1.70 mΩ	8,400 A ² s
169.6885.540_	40 A	Orange	85 mV	1.60 mΩ	12,000 A ² s
169.6885.550_	50 A	Red	80 mV	1.20 mΩ	26,000 A ² s
169.6885.560_	60 A	Blue	85 mV	0.90 mΩ	45,000 A ² s
169.6885.570_	70 A	Brown	90 mV	0.80 mΩ	70,000 A ² s
169.6885.580_	80 A	White	75 mV	0.72 mΩ	94,000 A ² s
169.6885.610_	100 A*	Purple	95 mV	0.50 mΩ	140,000 A ² s

* Not mentioned in the standards
Corresponding holder see Section "Fuse Holders."

FK3 MAXI® STYLE BLADE FUSE RATED 32V

RoHS

Dimensions

Dimensions in mm

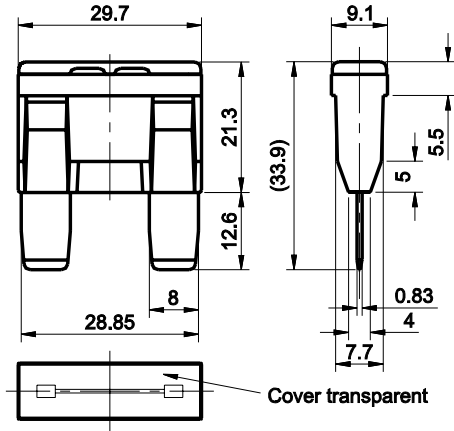

Pre-Arcing Time-Limits

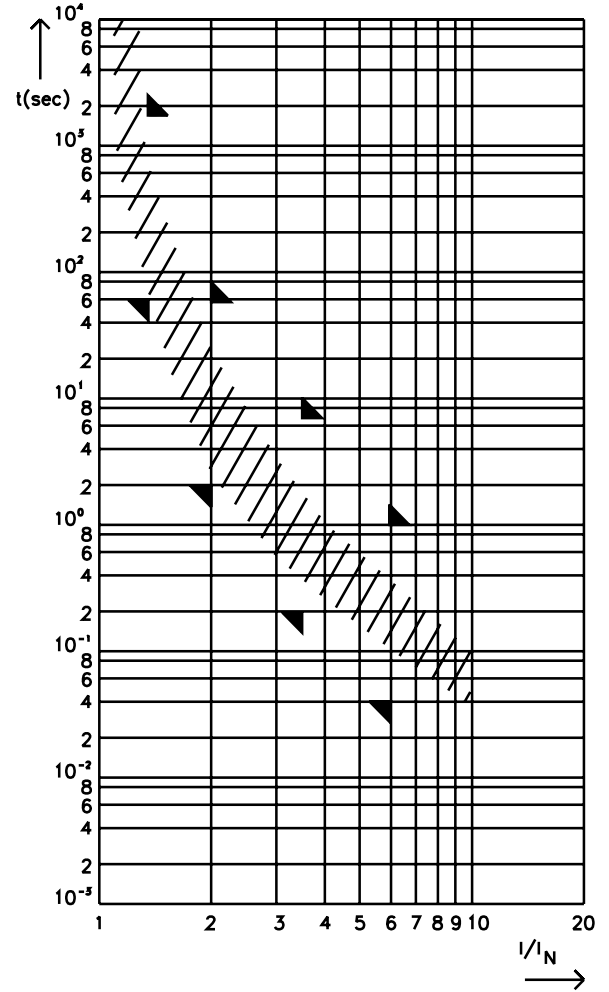

FI = 1.33 (max. operating current: $0.75 \times I_{rat}$ at 23°C)

TOE MAXI® STYLE BLADE FUSE RATED 58V

RoHS



Specifications

Insulating Body:	Out of thermoplastic (UL 94-V0, heat-resistant)
Cover:	Out of thermoplastic (V0, transparent), Visible melting-element
Terminals:	Blade contacts Copper alloy, gal, Sn / alliage cuivreux, gal. Sn Edge-protected
Interrupting Rating:	1000 A @58 VDC
Complies with:	ISO 8820-3:2002(E) UL 248 Special Purpose Fuses

Ordering Information

Part Number	Package Size
142.6885.5xx2	1000

Description

The TOE is a MAXI® style fuse rated at 58V, featuring three piece design with copper contacts for excellent reliability in harsh environment conditions and low voltage drop. Current ratings 20A thru 70A. With see-through cover for easy detection of blown fuses.

Time-Current Characteristics

% of Rating	Opening Time Min / Max (s)
100	360,000 s / -
135	60 s / 1,800 s
200	2 s / 60 s
350	0.20 s / 7 s
600	0.040 s / 1 s

Ratings

Part Number	Current Rating	Housing Color	Typ. Voltage Drop Littelfuse max.	Cold Resistance	I ² t
142.6885.5202	20 A	Yellow	110 mV	3.70 mΩ	1,900 A ² s
142.6885.5302	30 A	Green	100 mV	2.20 mΩ	6,000 A ² s
142.6885.5402	40 A	Orange	80 mV	1.60 mΩ	12,000 A ² s
142.6885.5502	50 A	Red	85 mV	1.20 mΩ	26,000 A ² s
142.6885.5602	60 A	Blue	85 mV	0.90 mΩ	45,000 A ² s
142.6885.5702	70 A	Brown	80 mV	0.80 mΩ	70,000 A ² s

Corresponding holder see Section "Fuse Holders."

TOE MAXI® STYLE BLADE FUSE RATED 58V

RoHS

Dimensions

Dimensions in mm

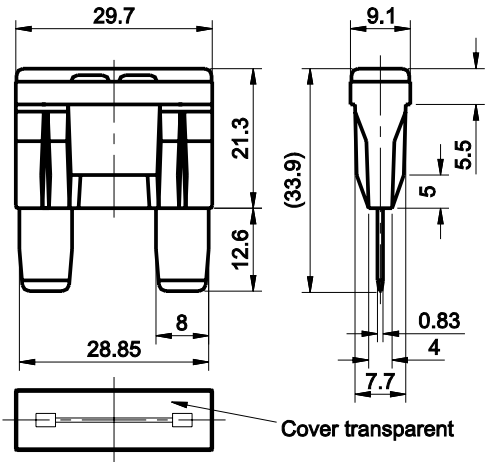

Pre-Arcing Time-Limits

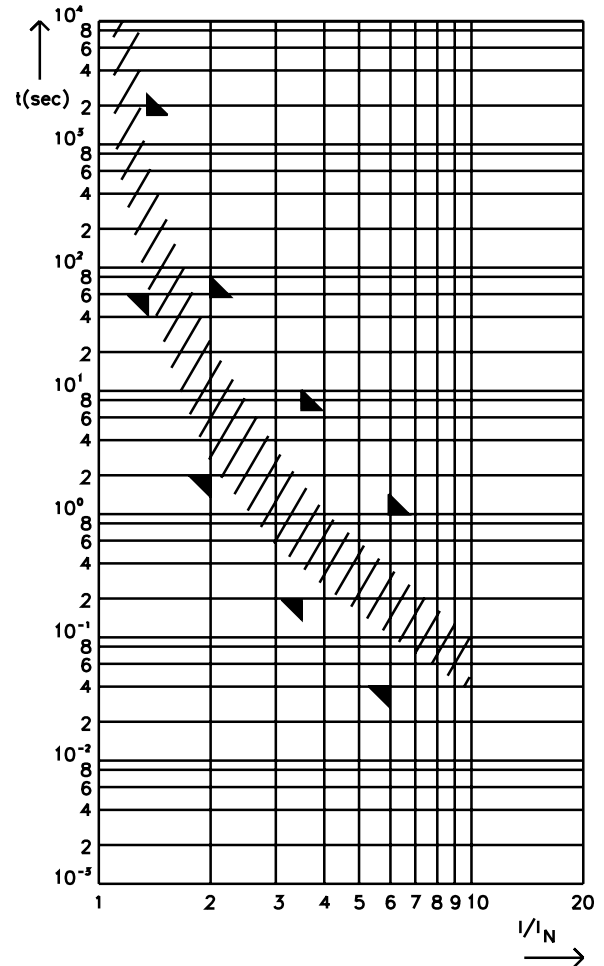

FI = 1.33 (max. operating current: $0.75 \times I_{rat}$ at 23°C)

FK3 MAXI® STYLE BLADE FUSE RATED 80V



Description

The FK3-80 is a MAXI® style fuse rated at 80V, featuring three piece design with copper contacts for excellent reliability in harsh environment conditions and low voltage drop. Current ratings 20A thru 50A. Filled with arc-quenching material.

Pre-Arcing Time-Limits

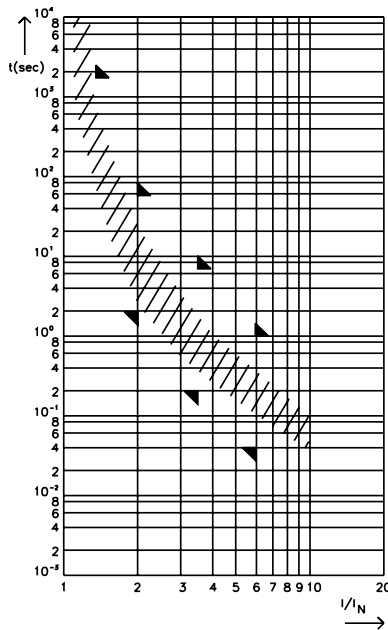

FI = 1.43 (max. operating current : $0.7 \times I_{rat}$ at 23°C)

Ratings

Part Number	Current Rating	Housing Color	Typ. Voltage Drop	Cold Resistance	I ² t
166.6885.520_	20 A	Yellow	120 mV	4.50 mΩ	2,160 A ² s
166.6885.530_	30 A	Green	160 mV	3.00 mΩ	4,950 A ² s
166.6885.540_	40 A	Orange	110 mV	1.65 mΩ	12,800 A ² s
166.6885.550_	50 A	Red	100 mV	1.20 mΩ	25,500 A ² s

Corresponding holder see Section "Fuse Holders."

Specifications

Insulating Body:	Out of thermoplastic (UL 94-V0, heat-resistant)
Cover:	Out of thermoplastic (UL 94-V0, heat-resistant) Red, not transparent
Terminals:	Blade contacts Copper alloy, gal. Sn Edge-protected
Interrupting Rating:	1000 A @80 VDC
Complies with:	UL 248 Special Purpose Fuses
cULus Recognized:	File No. E10480

Ordering Information

Part Number	Package Size
166.6885.5xx2	1000
166.6885.5xx1	10

Time-Current Characteristics

% of Rating	Opening Time Min / Max (s)
100	360,000 s / -
135	- / 1,800 s
200	2 s / 60 s
350	0.20 s / 7 s
600	0.040 s / 1 s

Dimensions

Dimensions in mm

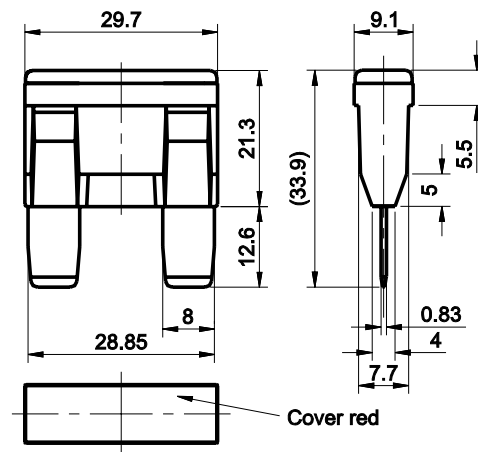

Cartridge Fuses



MCASE™ Cartridge Fuses Rated 32V	40
Low Profile JCASE® Fuse Rated 58V	42
JCASE® Fuse Rated 32V	44

MCASE™ CARTRIDGE FUSES RATED 32V

RoHS



Specifications

Voltage Rating:	32 VDC
Interrupting Ratings:	1000A @ 32 VDC
Operating Temperature Range:	-40°C to +125°C
Insertion Force:	44.1N Max. (9.9 lb.)
Extraction Force:	4N Min. (0.9 lb.) 24.5N Max. (5.5 lb)

Ordering Information

Part Number	Package Size
0695xxx.PX4	2000
0695xxx.L	50

Description

The MCASE™ is a cartridge style fuse with female terminals for 2.8 mm male terminals. It has a miniaturized footprint for optimal usage of space. It is a time delayed fuse and can handle inrush currents. MCASE™ is designed and patented by Littelfuse.

Time-Current Characteristics

% of Rating	Opening Time Min / Max (s)
100	100 hrs / -
135	60 s / 1800 s
200	5 s / 60 s
350	0.2 s / 7 s
600	0.04 s / 1 s

Ratings

Part Number	Current Rating	Housing Color	I ² t
0695015_	15 A	Grey	160 A ² s
0695020_	20 A	Blue	530 A ² s
0695025_	25 A	White	1140 A ² s
0695030_	30 A	Pink	970 A ² s
0695040_	40 A	Green	2950 A ² s

Dimensions

Dimensions in mm

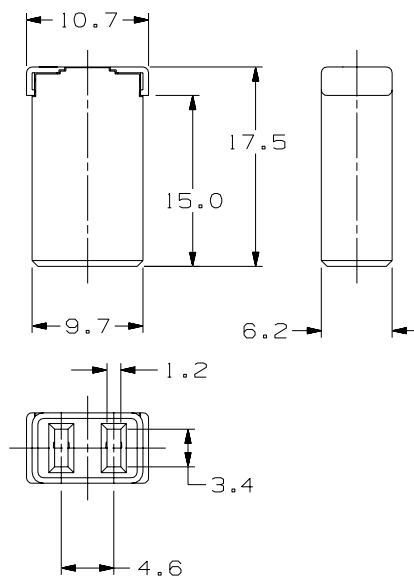

MCASE™ CARTRIDGE FUSES RATED 32V

RoHS

Dimensions

Dimensions in mm

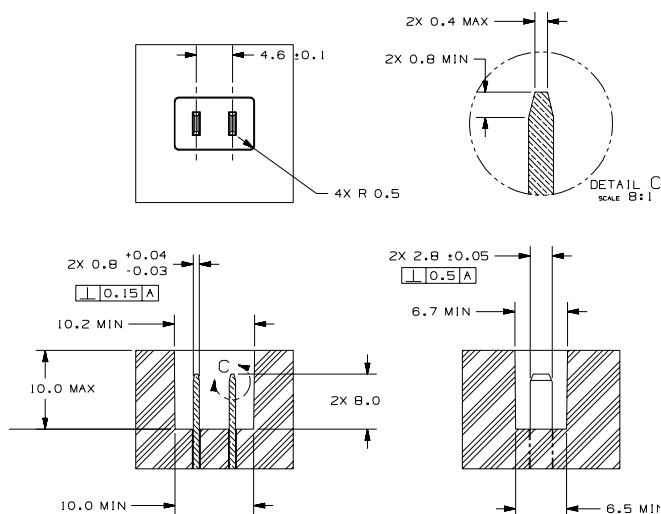

Time-Current Characteristics Curve

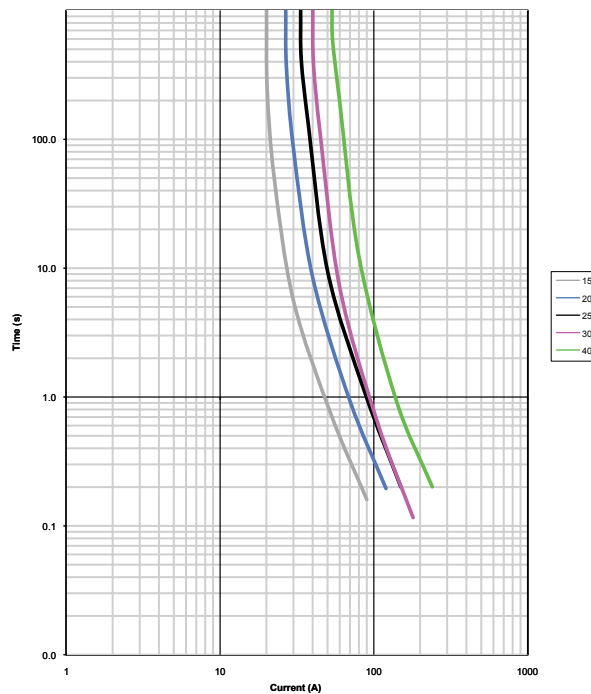

LOW PROFILE JCASE® FUSES RATED 58V

RoHS



Specifications

Voltage Rating:	58 VDC
Interrupting Rating:	1000A @ 58 VDC
Operating Temperature Range:	-40°C to + 125°C
Insertion Force:	53N Max. (12 lb.)
Extraction Force:	9N Min (2 lb.)

Ordering Information

Part Number	Package Size
0895xxx.T	10
0895xxx.U	500
0895xxx.Z	2000

Description

The Low Profile JCASE® fuse has similar performance characteristics as the standard JCASE® fuse. The lower overall height reduction allows for more space and weight savings and also allows for a shorter male blade terminal, saving additional weight and material savings in fuse box designs.

Time-Current Characteristics

% of Rating	Opening Time Min / Max (s)
100	360,000 s / -
135	60 s / 1800 s
200	4 s / 60 s
350	0.200 s / 7 s
600	0.040 s / 1 s

Ratings

Part Number	Current Rating	Housing Color	Cold Resistance	I²t
0895020_	20 A	Blue	4.48 mΩ	400 A²s
0895025_	25 A	White	3.39 mΩ	680 A²s
0895030_	30 A	Pink	2.68 mΩ	1780 A²s
0895040_	40 A	Green	1.89 mΩ	5470 A²s
0895050_	50 A	Red	1.08 mΩ	4880 A²s
0895060_	60 A	Yellow	0.83 mΩ	9600 A²s

Corresponding holder see Section "Fuse Holders."

LOW PROFILE JCASE® FUSES RATED 58V

Dimensions

Dimensions in mm

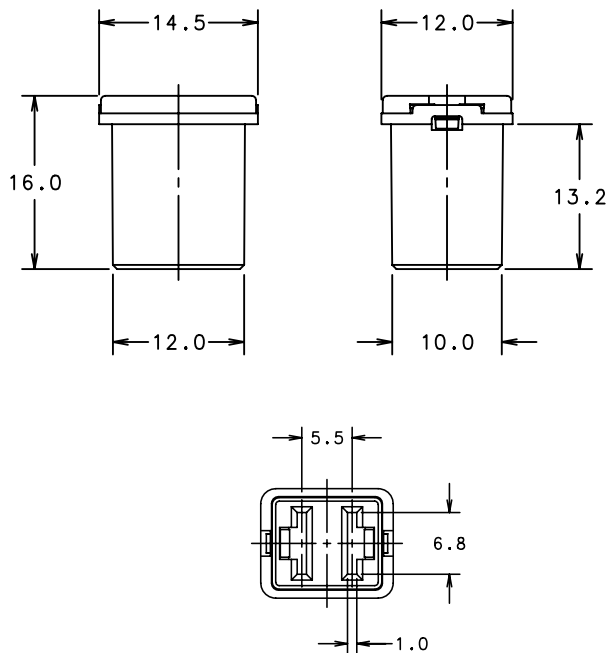

Time-Current Characteristics Curve

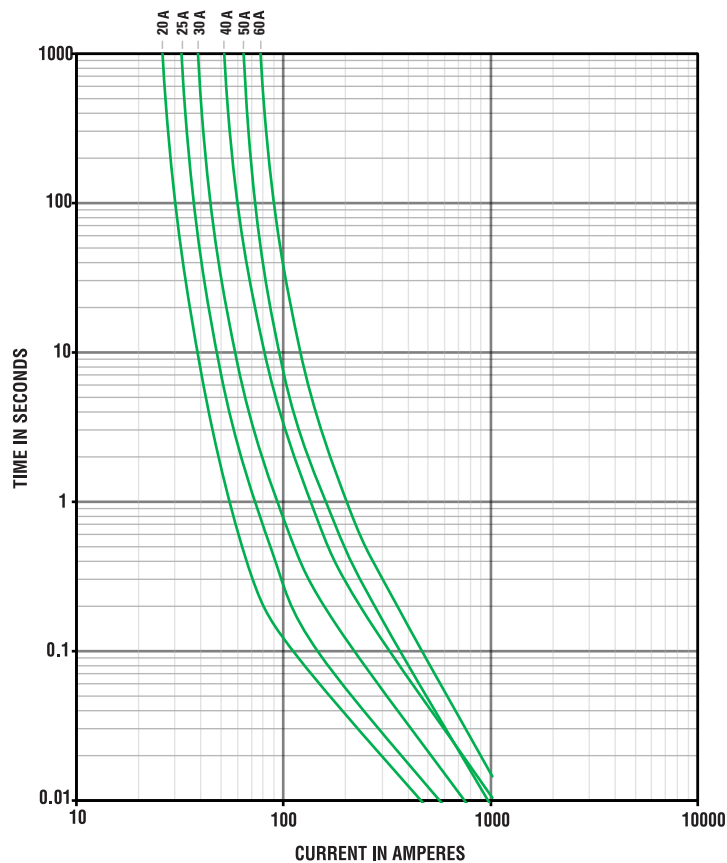

Temperature Derating Curve

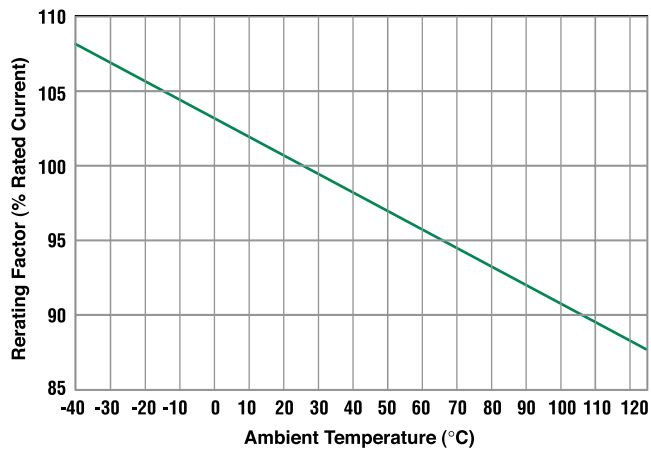

JCASE® CARTRIDGE FUSE RATED 32V



Specifications

Voltage Rating:	32 VDC
Interrupting Rating:	1000A @ 32 VDC
Operating Temperature Range:	-40°C to + 125°C
Insertion Force:	53N max. (12 lb.)
Extraction Force:	9N min. (2 lb.)

Ordering Information

Part Number	Package Size
0495xxx.T	10
0495xxx.U	500
0495xxx.Z	2200

Dimensions

Dimensions in mm

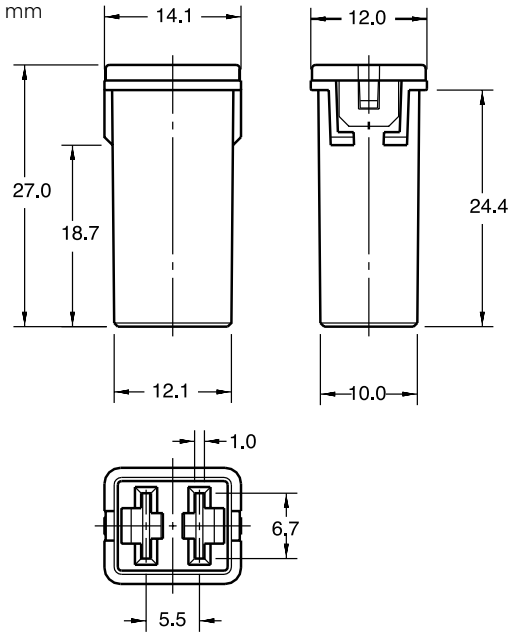

Description

The JCASE® is a cartridge style fuse with female terminal design. JCASE® provides both increased time delay and low voltage drop to protect high current circuits. JCASE® has the ability to handle inrush currents. The JCASE® was designed and patented by Littelfuse.

Time-Current Characteristics

% of Rating	Opening Time Min / Max (s)
110	360,000 s / -
135	60 s / 1800 s
200	4 s / 60 s
350	0.200 s / 7 s
600	0.040 s / 1 s

Ratings

Part Number	Current Rating	Housing Color	Typ. Voltage Drop	Cold Resistance	I²t
0495020_	20 A	Blue	106 mV	4.29 mΩ	1750 A²s
0495025_	25 A	White	101 mV	3.28 mΩ	3220 A²s
0495030_	30 A	Pink	91 mV	2.12 mΩ	1480 A²s
0495040_	40 A	Green	87 mV	1.30 mΩ	3650 A²s
0495050_	50 A	Red	88 mV	0.99 mΩ	8750 A²s
0495060_	60 A	Yellow	87 mV	0.76 mΩ	19500 A²s

Corresponding holder see Section "Fuse Holders."

JCASE[®] CARTRIDGE FUSE RATED 32V

Temperature Derating Curve

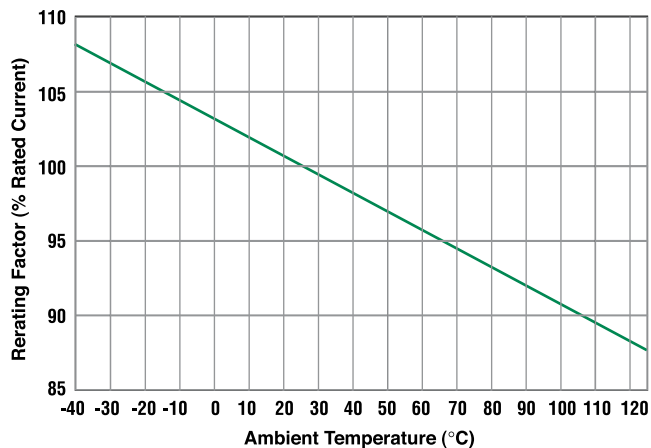

Time-Current Characteristic Curves

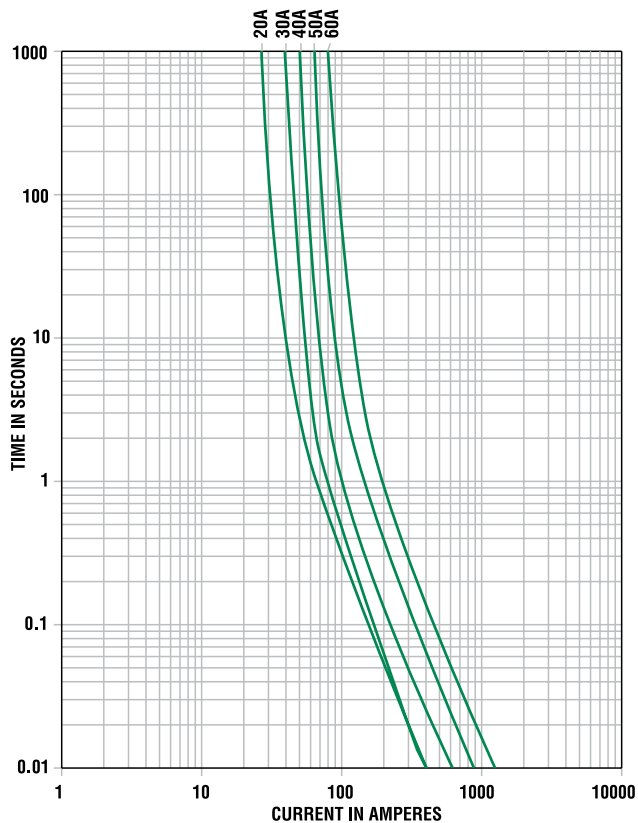

Bolt-down Fuses



MIDI® Style Bolt-down Fuse Rated 32V	47
Clear MIDI® Style Bolt-down Fuse Rated 32V	49
MIDI® Heavy Duty Bolt-down Fuse Rated 32V	51
BF1 Fuse Rated 32V	53
BF1 Fuse Rated 58V	55
MEGA® Fuse Rated 32V	57
MEGA® Low Temperature Fuse Rated 32V	59
UL Recognized Mega® Fuse Rated 32V	61
BF2 Fuse Rated 32V	63
BF2 Fuse Rated 58V	65
Fuse Strips for Diesel Rated 36V	67
Fuse Strips with Housing 80V	68
Fuse Strips for Battery-Powered Vehicles Rated 80V	69
Fuse Strips with Housing for Battery-Powered Vehicles Rated 80V	70
HSB Fuse Rated 32V	71
CF Fuse Rated 58V	72

MIDI® STYLE BOLT-DOWN FUSE RATED 32V



Description

This MIDI® style fuse offers a bolt-on space saving fuse for high current wiring protection and provides time delay characteristics with “Diffusion Pill Technology”. The MIDI® was designed and patented by Littelfuse.

Specifications

Interrupting Rating:	1000A @ 32 VDC
Voltage Rating:	32 VDC
Operating Temperature Range:	-40°C to + 125°C
Housing:	Out of thermoplastic
Terminal:	Tin plated Copper
Mounting Torque M5:	4.5 Nm +/- 1Nm
Mounting Torque M6:	5.5-6.5 Nm +/- 1Nm (Except 23A)
Complies with:	ISO 8820-5 UL 248 Special Purpose Fuses













Ordering Information

Part Number	Package Size
0498xxx.H	100
0498xxx.M	1000

Time-Current Characteristics

% of Rating	Opening Time Min / Max (s)	
	23-125A	150-200A
75	- / -	360,000 s / -
100	360,000 s / -	- / -
110	14,400 s / -	- / -
150	90 s / 3,600 s	- / -
200	3 s / 100 s	1 s / 15 s
300	0.3 s / 3 s	- / -
350	- / -	0.3 s / 5 s
500	0.1 s / 1 s	0.1 s / 1 s

Ratings

Part Number	Current Rating	Housing Color	Typ. Voltage Drop	Cold Resistance	I ² t
0498023._ ²	23 A		90 mV	3.43 mΩ	1,800 A ² s
0498030._ ²	30 A		65 mV	2.06 mΩ	4,200 A ² s
0498040._	40 A		65 mV	1.398 mΩ	10,000 A ² s
0498050._	50 A		65 mV	1.025 mΩ	13,000 A ² s
0498060._	60 A		68 mV	0.865 mΩ	21,700 A ² s
0498070._	70 A		70 mV	0.72 mΩ	24,000 A ² s
0498080._	80 A		58 mV	0.541 mΩ	24,600 A ² s
0498100._ ²	100 A		60 mV	0.457 mΩ	51,300 A ² s
0498125._ ²	125 A		71 mV	0.394 mΩ	73,200 A ² s
0498150._ ^{1,2}	150 A		77 mV	0.323 mΩ	81,900 A ² s
0498175._ ^{1,2}	175A		77 mV	0.285 mΩ	100,000 A ² s
0498200._ ^{1,2}	200A		77 mV	0.261 mΩ	125,000 A ² s

Note 1: Short circuit protector only Note 2: not UL approved

MIDI® STYLE BOLT-DOWN FUSE RATED 32V



Dimensions

Dimensions in mm

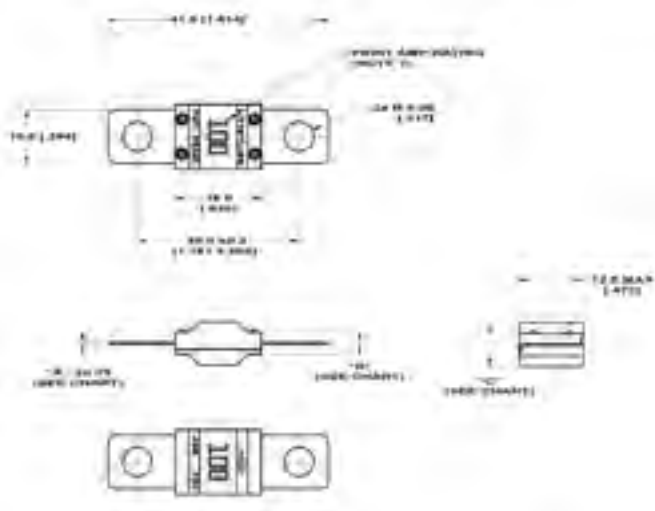

Temperature Derating Curve

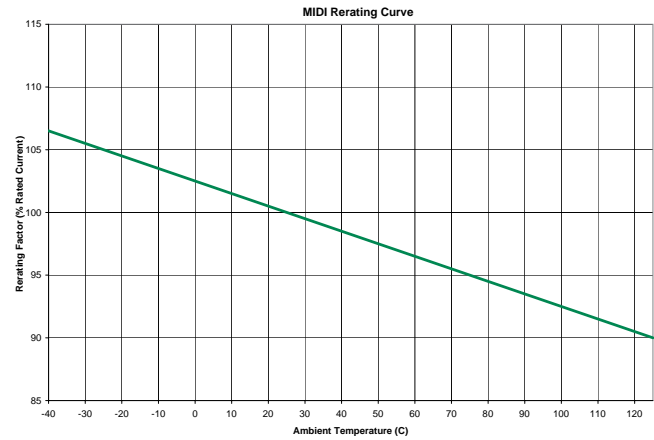

Time-Current Characteristic Curves

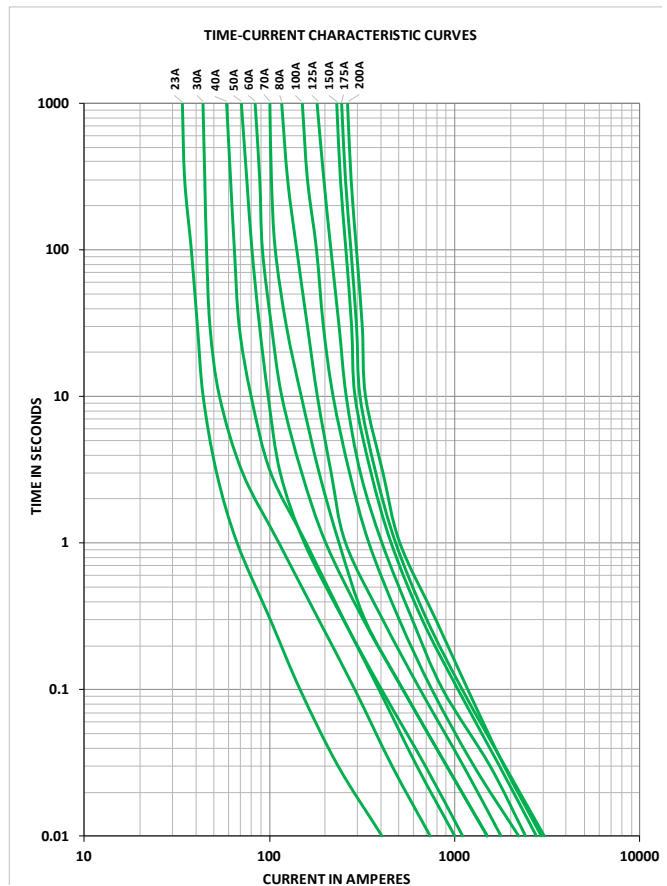

Part Number	"A" mm (inch)	"B" mm (inch)	"C" mm (inch)
0498023_	0.41 (0.016)	4.0 (0.157)	8.0 (0.315)
0498030_	0.41 (0.016)	4.0 (0.157)	8.0 (0.315)
0498040_	0.41 (0.016)	4.0 (0.157)	8.0 (0.315)
0498050_	0.41 (0.016)	4.0 (0.157)	8.0 (0.315)
0498060_	0.41 (0.016)	4.0 (0.157)	8.0 (0.315)
0498070_	0.41 (0.016)	4.0 (0.157)	8.0 (0.315)
0498080_	0.41 (0.016)	4.0 (0.157)	8.0 (0.315)
0498100_	0.63 (0.025)	4.3 (0.169)	8.3 (0.327)
0498125_	0.63 (0.025)	4.3 (0.169)	8.3 (0.327)
0498150_	0.63 (0.025)	4.3 (0.169)	8.3 (0.327)
0498175_	0.63 (0.025)	4.3 (0.169)	8.3 (0.327)
0498200_	0.63 (0.025)	4.3 (0.169)	8.3 (0.327)

CLEAR MIDI® STYLE BOLT-DOWN FUSE RATED 32V

RoHS



Description

This MIDI® style fuse offers a bolt-on space saving fuse for high current wiring protection and provides time delay characteristics with “Diffusion Pill Technology”. The MIDI® was designed and patented by Littelfuse.

Specifications

Interrupting Rating:	1000A @ 32 VDC
Voltage Rating:	32 VDC
Operating Temperature Range:	-40°C to + 125°C
Housing:	Transparent Nylon Composite
Terminal:	Tin plated Copper
Mounting Torque M5:	4.5 Nm +/- 1Nm
Complies with:	ISO 8820-5 UL 248 Special Purpose Fuses

Ordering Information

Part Number	Package Size
0498xxx.SXT	20
0498xxx.MXT	1000

Time-Current Characteristics

% of Rating	Opening Time Min / Max (s)	
	30-125A	150-200A
75	- / -	360,000 s / -
100	360,000 s / -	- / -
110	14,400 s / -	- / -
150	90 s / 3,600 s	- / -
200	3 s / 100 s	1 s / 15 s
300	0.3 s / 3 s	- / -
350	- / -	0.3 s / 5 s
500	0.1 s / 1 s	0.1 s / 1 s

Ratings

Part Number	Current Rating	Font Color	Typ. Voltage Drop	Cold Resistance	I ² t
0498030_	30 A	Orange	65 mV	2.06 mΩ	4200
0498040_	40 A	Green	65 mV	1.398 mΩ	10000
0498050_	50 A	Red	65 mV	1.025 mΩ	13000
0498060_	60 A	Yellow	68 mV	0.865 mΩ	21700
0498070_	70 A	Brown	70 mV	0.72 mΩ	24000
0498080_	80 A	White	58 mV	0.541 mΩ	24600
0498100_	100 A	Blue	60 mV	0.457 mΩ	51300
0498125_	125 A	Pink	71 mV	0.394 mΩ	73200
0498150_1	150 A	Grey	77 mV	0.323 mΩ	81900
0498175_1	175 A	Dark Grey	77 mV	0.285 mΩ	100000
0498200_1	200 A	Purple	77 mV	0.261 mΩ	125000

Note 1: Short circuit protectors only.

CLEAR MIDI® STYLE BOLT-DOWN FUSE RATED 32V

Temperature Derating Curve

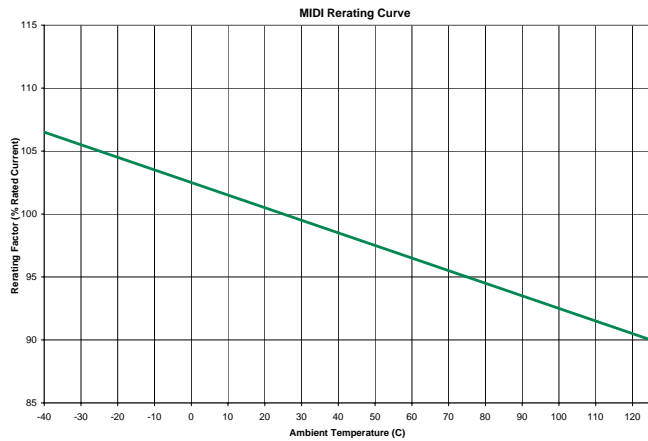

Time-Current Characteristic Curves

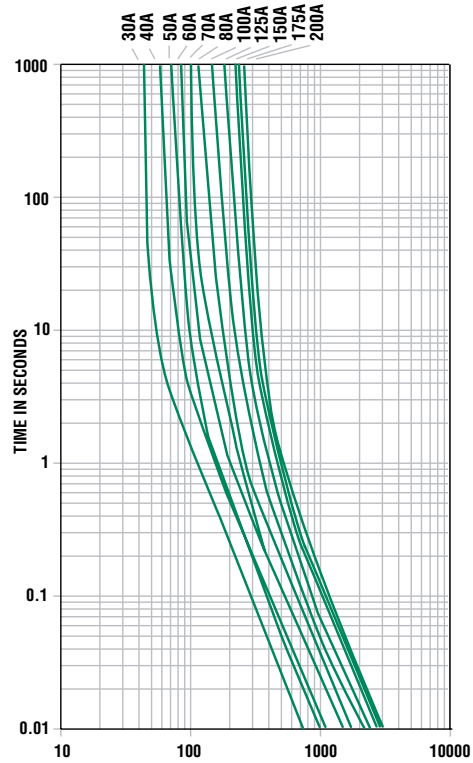

Dimensions

Dimensions in mm

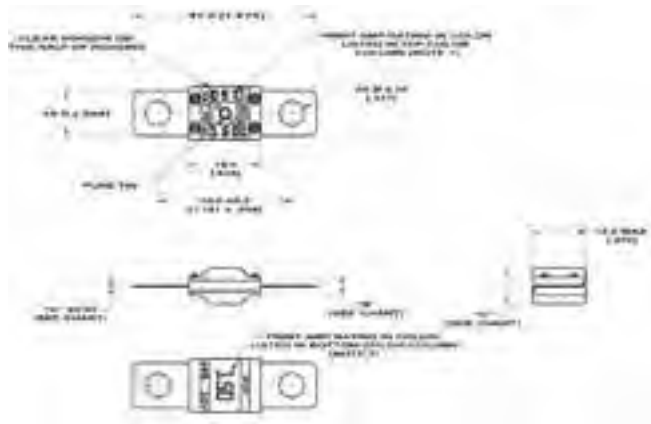

Ratings

Part Number	"A" mm (inches)	"B" mm (inches)	"C" mm (inches)
0498030_	.41 (.016)	4.0 (.157)	8.0 (.315)
0498040_	.41 (.016)	4.0 (.157)	8.0 (.315)
0498050_	.41 (.016)	4.0 (.157)	8.0 (.315)
0498060_	.41 (.016)	4.0 (.157)	8.0 (.315)
0498070_	.41 (.016)	4.0 (.157)	8.0 (.315)
0498080_	.41 (.016)	4.0 (.157)	8.0 (.315)
0498100_	0.63 (.025)	4.3 (.169)	8.3 (.327)
0498125_	0.63 (.025)	4.3 (.169)	8.3 (.327)
0498150_	0.63 (.025)	4.3 (.169)	8.3 (.327)
0498175_	0.63 (.025)	4.3 (.169)	8.3 (.327)
0498200_	0.63 (.025)	4.3 (.169)	8.3 (.327)

MIDI® HEAVY DUTY BOLT-DOWN FUSE RATED 32V

RoHS



Description

This MIDI® style fuse offers a bolt-on space saving fuse for high current wiring protection and provides time delay characteristics with “Diffusion Pill Technology”. The MIDI® was designed and patented by Littelfuse.

Specifications

Voltage Rating:	32 VDC
Interrupting Ratings:	5000A @ 14 VDC
Operating Temperature Range:	-40°C to +125°C
Housing:	Transparent Nylon Composite
Terminal:	Tin plated Copper
Mounting Torque M5:	4.5 Nm +/- 1Nm
Complies with:	ISO 8820-5 UL 248 Special Purpose Fuses

Ordering Information

Part Number	Package Size
0498xxx.MXT-HD	1000
0498xxx.UXT-HD	500

Time-Current Characteristics

% of Rating	Opening Time Min / Max (s)	
	30-125A	150-200A
75	- / -	360,000 s / -
100	360,000 s / -	- / -
110	14,400 s / -	- / -
150	90 s / 3,600 s	- / -
200	3 s / 100 s	1 s / 15 s
300	0.3 s / 3 s	- / -
350	- / -	0.3 s / 5 s
500	0.1 s / 1 s	0.1 s / 1 s

Ratings

Part Number	Current Rating (A)	Font Color	Typical Voltage Drop	Typical Cold Resistance	I ² t (A ² s)
0498030.MXT-HD	30 A	Orange	65 mV	2.06 mΩ	4200
0498040.MXT-HD	40 A	Green	65 mV	1.398 mΩ	10000
0498050.MXT-HD	50 A	Red	65 mV	1.025 mΩ	13000
0498060.MXT-HD	60 A	Yellow	68 mV	0.865 mΩ	21700
0498070.MXT-HD	70 A	Brown	70 mV	0.72 mΩ	24000
0498080.MXT-HD	80 A	White	58 mV	0.541 mΩ	24600
0498100.MXT-HD	100 A	Blue	60 mV	0.457 mΩ	51300
0498125.MXT-HD	125 A	Pink	71 mV	0.394 mΩ	73200
0498150.MXT-HD ¹	150 A	Grey	77 mV	0.323 mΩ	81900
0498175.MXT-HD ¹	175 A	Dark Grey	77 mV	0.285 mΩ	100000
0498200.MXT-HD ¹	200 A	Purple	77 mV	0.261 mΩ	125000

Note 1: Short circuit protectors only.

MIDI® HEAVY DUTY BOLT-DOWN FUSE RATED 32V

Temperature Derating Curve

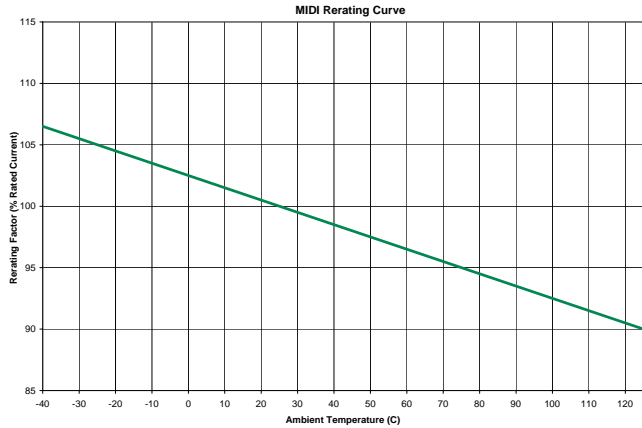

Time-Current Characteristic Curves

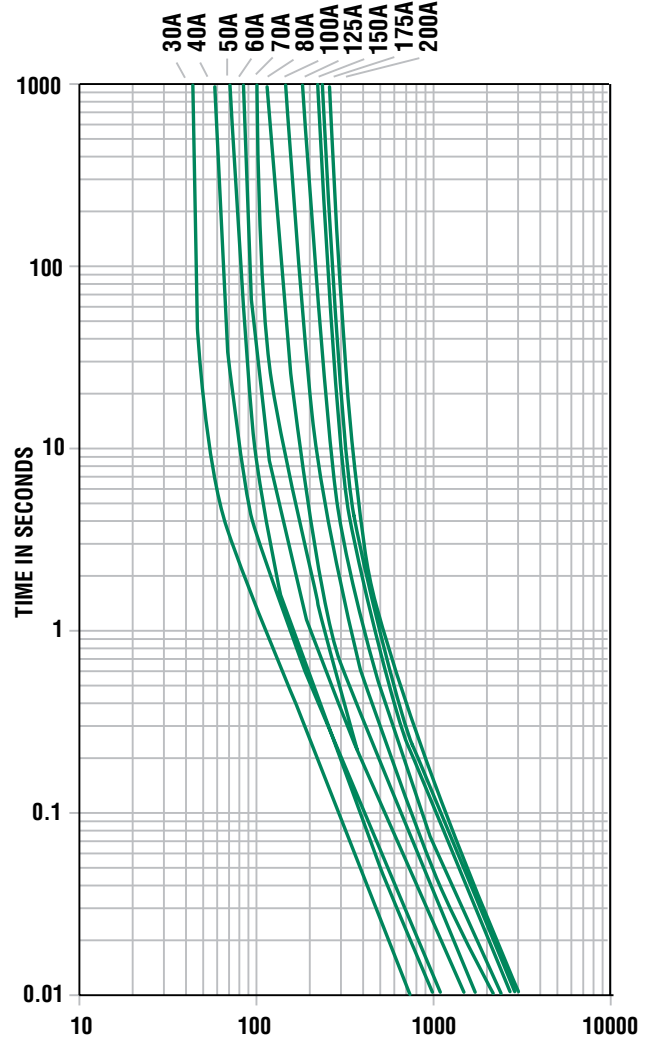

Dimensions

Dimensions in mm

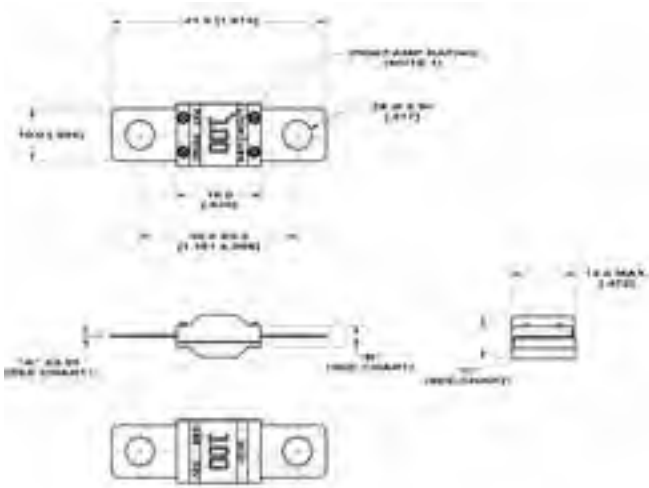

Part Number Artikel-Nr.	"A" mm (inch)	"B" mm (inch)	"C" mm (inch)
0498030.MXT-HD	0.41 (0.016)	4.0 (0.157)	8.0 (0.315)
0498040.MXT-HD	0.41 (0.016)	4.0 (0.157)	8.0 (0.315)
0498050.MXT-HD	0.41 (0.016)	4.0 (0.157)	8.0 (0.315)
0498060.MXT-HD	0.41 (0.016)	4.0 (0.157)	8.0 (0.315)
0498070.MXT-HD	0.41 (0.016)	4.0 (0.157)	8.0 (0.315)
0498080.MXT-HD	0.41 (0.016)	4.0 (0.157)	8.0 (0.315)
0498100.MXT-HD	0.63 (0.025)	4.3 (0.169)	8.3 (0.327)
0498125.MXT-HD	0.63 (0.025)	4.3 (0.169)	8.3 (0.327)
0498150.MXT-HD	0.63 (0.025)	4.3 (0.169)	8.3 (0.327)
0498175.MXT-HD	0.63 (0.025)	4.3 (0.169)	8.3 (0.327)
0498200.MXT-HD	0.63 (0.025)	4.3 (0.169)	8.3 (0.327)

BF1 FUSE RATED 32V

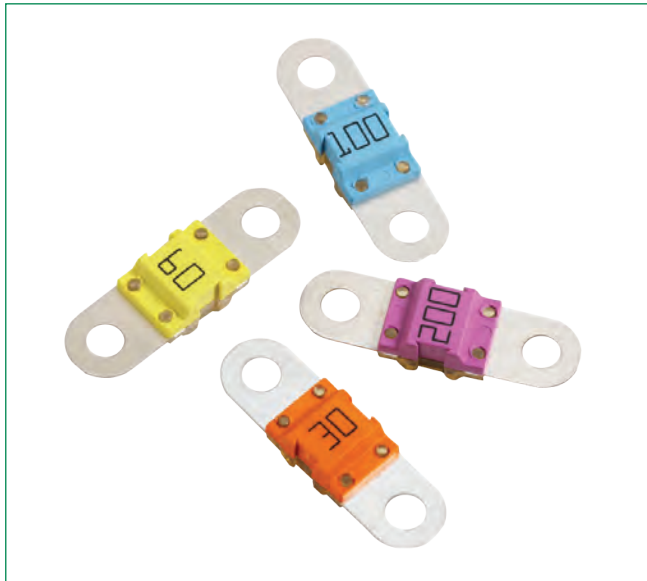













Description

This BF1 fuse is rated at 32V and offers a bolt-on fuse for high current wiring protection. Current rating 23A - 200A; with transparent housing for easy detection of blown fuses.

Ordering Information

Mounting Torque	Part Number	Package Size
M5	153.5631.xxx2	1000
M5	153.5631.xxx1	10
M6	153.7010.xxx2	1000
M6	153.7000.xxx2	500

Ratings

Part Number		Current Rating	Housing Color	Typ. Voltage Drop	Cold Resistance	I ² t
M5	M6					
153.5631.523_1,2	-	23 A		105 mV	3.50 mΩ	1,400 A ² s
153.5631.530_	153.5631.530_2	30 A		105 mV	2.70 mΩ	5,100 A ² s
153.5631.540_	153.7010.540_	40 A		90 mV	1.56 mΩ	6,800 A ² s
153.5631.550_	153.7010.550_	50 A		80 mV	1.03 mΩ	6,900 A ² s
153.5631.560_	153.7010.560_	60 A		75 mV	0.75 mΩ	16,200 A ² s
153.5631.570_	153.7010.570_	70 A		70 mV	0.64 mΩ	22,000 A ² s
153.5631.580_	153.7010.580_	80 A		70 mV	0.55 mΩ	25,600 A ² s
153.5631.610_	153.7010.610_	100 A		70 mV	0.44 mΩ	42,500 A ² s
153.5631.612_	153.7010.612_	125 A		70 mV	0.34 mΩ	62,500 A ² s
153.5631.615_1	153.7010.615_1	150 A		70 mV	0.29 mΩ	83,400 A ² s
-	153.7000.615_3	150 A		70 mV	0.33 mΩ	98,000 A ² s
153.5631.620_3	153.7000.620_3	200 A		70 mV	0.24 mΩ	126,000 A ² s

Corresponding holder see Section "Fuse Holders."

Note 1: not mentioned in ISO standard Note 2: Not UL rated Note 3: Short Circuit Protector only

Specifications

Housing:	Out of thermoplastic (UL 94-V0, heat-resistant)
Terminals:	Visible melting element Copper alloy, gal. Sn 2 x M5 or M6 bolts, distance 30 mm
Mounting Torque M5:	4.5 Nm +/- 1Nm
Mounting Torque M6:	6.0 Nm +/- 1Nm
Interrupting Rating:	23A & 30A: 1000A @32 VDC 40A - 150A: 2000A @32 VDC 200A: 1500A @32 VDC
Complies with:	ISO 8820-5 UL 248 Special Purpose Fuses
Operating Temperature:	-40 to 125 degrees C

Time-Current Characteristics

% of Rating	Opening Time Min / Max (s)	
	23-150A Fuses	150-200A Short Circuit Protectors
75	- / -	360,000 s / -
100	360,000 s / -	- / -
110	14,400 s / -	- / -
150	90 s / 3,600 s	- / -
200	3 s / 100 s	1 s / 15 s
300	0.300 s / 3 s	- / -
350	- / -	0.300 s / 5 s
500	0.100 s / 1 s	- / -
600	- / -	0.100 s / 1 s

BF1 FUSE RATED 32V



Dimensions

Dimensions in mm

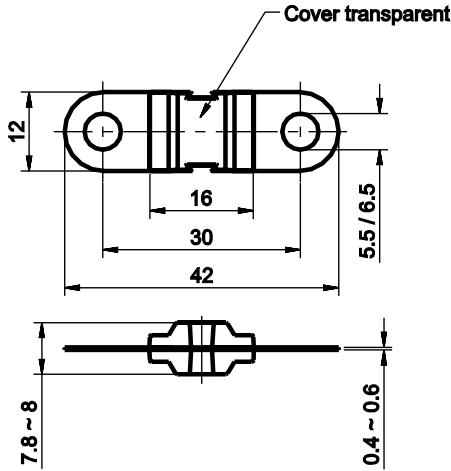

Pre-Arcing Time-Limits

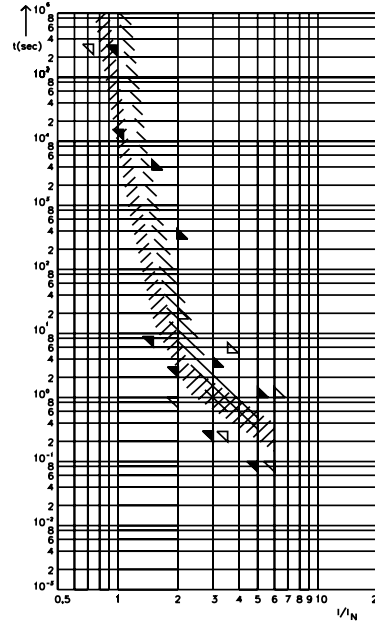

23 A - 150 A: FI = 1.25 (max. operating current: $0.8 \times I_{rat}$ at 23°C)

200 A: FI = 2.00 (max. operating current: $0.5 \times I_{rat}$ at 23°C)

Derating

Individual derating curves by rating can be ordered through your Littelfuse contact person.

BF1 FUSE RATED 58V



Description

This BF1 fuse is rated at 58V and offers a bolt-on fuse for high current wiring protection. Current rating 30A - 200A; with transparent housing for easy detection of blown fuses.

Specifications

Housing:	Out of thermoplastic (UL 94-V0, heat-resistant) Visible melting element
Terminals:	Copper alloy, gal. Sn 2 x M5 bolts, distance 30 mm
Mounting Torque:	4.5 Nm +/- 1Nm
Interrupting Rating:	1000A @ 58 VDC
Complies with:	ISO 8820-5 UL 248 Special Purpose Fuses
Operating temperature:	-40 to 125 degrees C











Ordering Information

Part Number	Package Size
142.5631.xxx2	500

Time-Current Characteristics

% of Rating	Opening Time Min / Max (s)	
	30-150A Fuses	200A Short Circuit Protectors
75	- / -	360,000 s / -
100	360,000 s / -	- / -
110	14,400 s / -	- / -
150	90 s / 3,600 s	- / -
200	3 s / 100 s	1 s / 15 s
300	0.300 s / 3 s	- / -
350	- / -	0.300 s / 5 s
500	0.100 s / 1 s	- / -
600	- / -	0.100 s / 1 s

Ratings

Part Number	Current Rating	Housing Color	Typ. Voltage Drop	Cold Resistance	I ² t
142.5631.5302 ¹	30 A		105 mV	2.70 mΩ	5,100 A ² s
142.5631.5402	40 A		90 mV	1.56 mΩ	6,800 A ² s
142.5631.5502	50 A		80 mV	1.03 mΩ	6,900 A ² s
142.5631.5602	60 A		75 mV	0.75 mΩ	16,200 A ² s
142.5631.5702	70 A		70 mV	0.64 mΩ	22,000 A ² s
142.5631.5802	80 A		70 mV	0.55 mΩ	25,600 A ² s
142.5631.6102	100 A		70 mV	0.44 mΩ	42,500 A ² s
142.5631.6122	125 A		70 mV	0.34 mΩ	62,500 A ² s
142.5631.6152	150 A		70 mV	0.29 mΩ	83,400 A ² s
142.5631.6202 ²	200 A		70 mV	0.24 mΩ	126,000 A ² s

Corresponding holder see Section "Fuse Holders."
Note 1: Not UL rated Note 2: Short Circuit Protector only

BF1 FUSE RATED 58V



Dimensions

Dimensions in mm

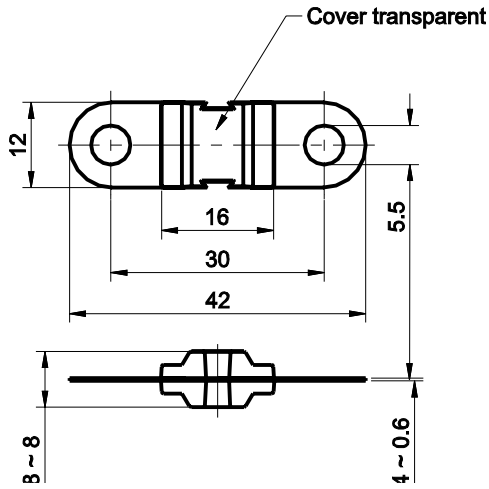

Pre-Arcing Time-Limits

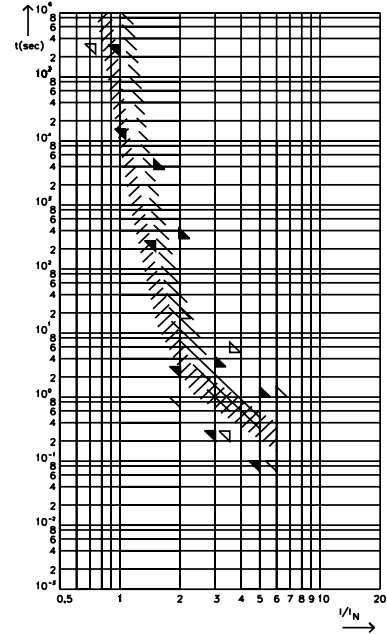

30 A - 150 A: FI = 1.25 (max. operating current: $0.8 \times I_{rat}$ at 23°C)
 200 A: FI = 2.00 (max. operating current: $0.5 \times I_{rat}$ at 23°C)

Derating

Individual derating curves by rating can be ordered through your Littelfuse contact person.

MEGA® FUSE RATED 32V



Specifications

Interrupting Rating:	2000A @ 32 VDC
Voltage Rating:	32 VDC
Operating Temperature Range:	-40°C to + 125°C
Housing:	PPA (33%/35% GF)
Terminals:	Copper (Silver plated copper available) M6 or M8 bolts available
Mounting Torque:	8-14 Nm M6 12-18 Nm M8
Complies with:	ISO 8820-5

Ordering Information

Part Number	Package Size	Plating	Bolt Size	Rating
0298xxx.ZXH	500	none	M8	300 - 500
0298xxx.ZXEH	500	none	M8	80 - 250
0298xxx.ZXB	500	Ag	M8	40 - 250
0298xxx.ZXA	500	none	M6	80 - 500

Time-Current Characteristics

% of Rating	Opening Time Min / Max (s)	
	40-250	300-500
75	- / -	14,400 s / -
100	14,400 s / -	- / -
135	120 s / 1800 s	- / -
200	1 s / 15 s	1 s / 15 s
350	0.300 s / 5 s	0.500 s / 5 s
600	0.100 s / 1 s	- / -

Description

The MEGA® Fuse is designed for high current circuit protection up to 500A with "Diffusion Pill Technology." The MEGA® Fuse also provides time delay characteristics. Designed and patented by Littelfuse, the MEGA® Fuse is ideal for battery and alternator protection application and other heavy gauge cables requiring ultra-high current protection.

Ratings

Part Number	Current Rating	Font Color	Typ. Voltage Drop	Cold Resistance	I2t
0298040._1	40 A	-	132 mV	2.510 mΩ	-
0298060._1	60 A	-	119 mV	1.504 mΩ	-
0298080._	80 A	Red	87 mV	0.720 mΩ	-
0298100._	100 A	Yellow	87 mV	0.562 mΩ	31100 A²s
0298125._	125 A	Green	80 mV	0.423 mΩ	57800 A²s
0298150._	150 A	Orange	92 mV	0.352 mΩ	100000 A²s
0298175._	175 A	White	86 mV	0.294 mΩ	168000 A²s
0298200._	200 A	Blue	83 mV	0.257 mΩ	204000 A²s
0298225._	225 A	Brown	82 mV	0.222 mΩ	257000 A²s
0298250._	250 A	Pink	82 mV	0.201 mΩ	389000 A²s
0298300._2	300 A	Grey	74 mV**	0.167 mΩ	-
0298350._2	350 A	Dark Green	68 mV**	0.138 mΩ	-
0298400._2	400 A	Purple	64 mV**	0.126 mΩ	-
0298450._2	450 A	Light Yellow	60 mV**	0.112 mΩ	-
0298500._2	500 A	Brown	58 mV**	0.092 mΩ	-

Note 1: Not mentioned in ISO standards Note 2: Short Circuit Protector only
** Voltage Drop measurements for short circuit protectors taken at 75% of rated current.

MEGA® FUSE RATED 32V

RoHS

Dimensions

Dimensions in mm

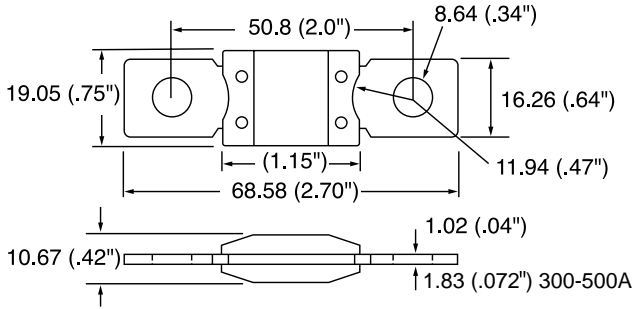

Time-Current Characteristic Curves

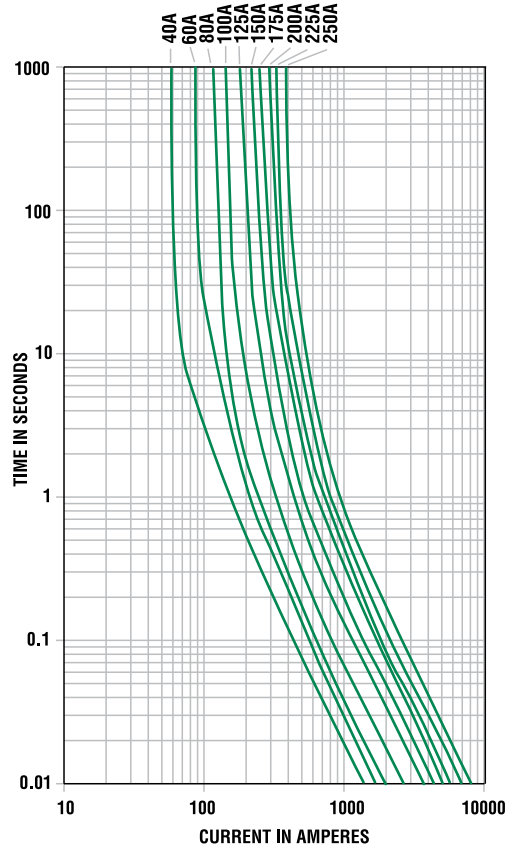

Temperature Rerating Curve

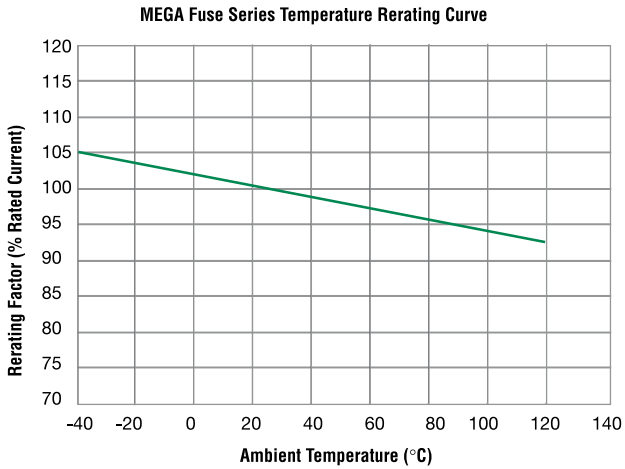

MEGA® LOW TEMPERATURE FUSE RATED 32V

RoHS



Specifications

Interrupting Rating:	2000A @ 32 VDC
Voltage Rating:	32 VDC
Operating Temperature Range:	-40°C to + 125°C
Housing:	35% GF Nylon
Terminals:	Copper (Silver plated copper available) M8 bolts
Mounting Torque:	12-18 Nm M8

Ordering Information

Part Number	Package Size	Plating	Rating
0298125.ZXBLT	500	Ag	125
0298xxx.ZXEH-LT	500	none	150 - 275

Description

The MEGA® Fuse is designed for high current circuit protection up to 275A with "Diffusion Pill Technology." The MEGA® Fuse also provides time delay characteristics. Designed and patented by Littelfuse, the MEGA® Fuse is ideal for battery and alternator protection application and other heavy gauge cables requiring ultra-high current protection.

Time-Current Characteristics

% of Rating	Opening Time Min / Max (s)
	150-275
100	4 hrs / -
135	120 s / 1800 s
200	1 s / 150 s
350	0.300 s / 5 s
600	0.100 s / 1 s

Ratings

Part Number	Current Rating	Font Color	Typ. Voltage Drop	Cold Resistance	I2t
0298125.ZXBLT	125 A	□	67 mV	0.330 mΩ	57000 A²s
0298150.ZXEH-LT	150 A	□	62 mV	0.258 mΩ	59000 A²s
0298175.ZXEH-LT	175 A	□	65 mV	0.232 mΩ	123000 A²s
0298200.ZXEH-LT	200 A	□	61 mV	0.214 mΩ	140000 A²s
0298225.ZXEH-LT	225 A	□	57 mV	0.177 mΩ	317000 A²s
0298250.ZXEH-LT	250 A	□	54 mV	0.144 mΩ	637000 A²s
0298275.ZXEH-LT	275 A	□	53 mV	0.122 mΩ	800000 A²s

Last figure of article no. = packaging code
Corresponding holder see Section "Fuse Holders."

MEGA® LOW TEMPERATURE FUSE RATED 32V

RoHS

Dimensions

Dimensions in mm

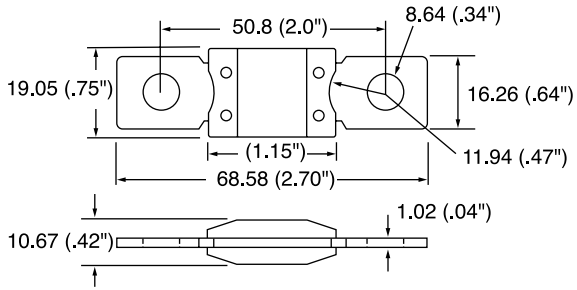

Time-Current Characteristic Curves

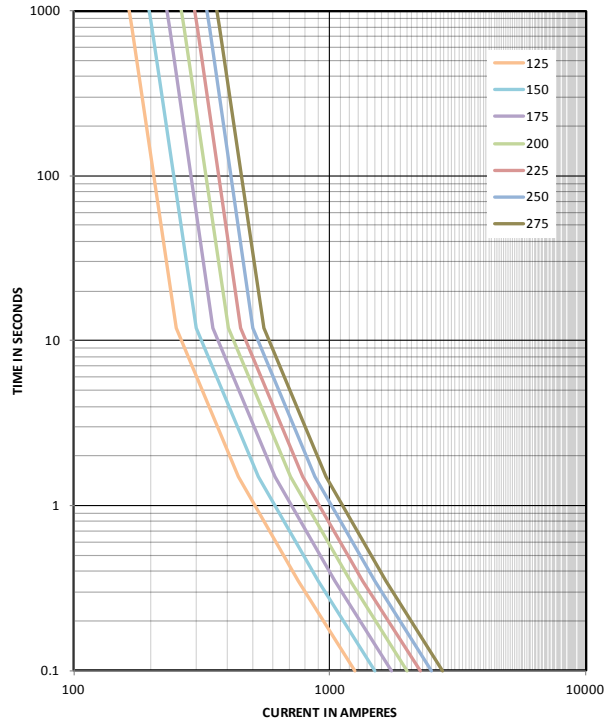

Temperature Rerating Curve

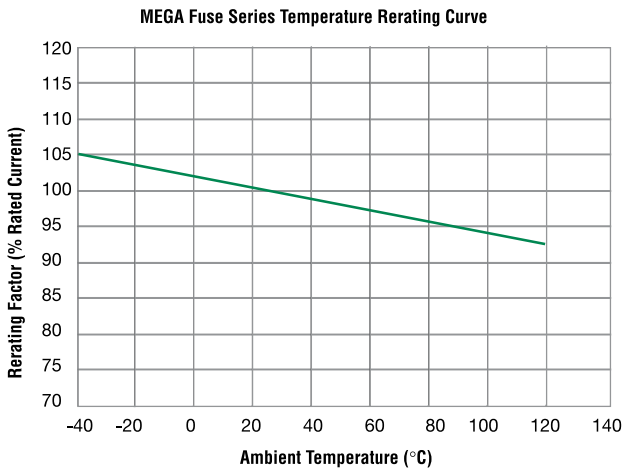

UL RECOGNIZED MEGA® FUSE RATED 32V



Description

The MEGA® Fuse is designed for high current circuit protection with “Diffusion Pill Technology.” The MEGA® Fuse also provides time delay characteristics. Designed and patented by Littelfuse, the MEGA® Fuse is ideal for battery and alternator protection application and other heavy gauge cables requiring ultra-high current protection.

Specifications

Interrupting Rating:	2000A @ 32 VDC
Voltage Rating:	32 VDC
Operating Temperature Range:	-40°C to + 125°C
Housing:	PA66
Terminals:	Copper
	M8 bolts holes
Mounting Torque:	12-18 Nm M8
Complies with:	ISO 8820-5
	UL 248 Special Purpose Fuses

Ordering Information

Part Number	Package Size
0298xxx.ZXEH-UL	500

Time-Current Characteristics

% of Rating	Opening Time Min / Max (s)
	80A-175A
75	- / -
100	14,400 s / -
135	120 s / 1800 s
200	1 s / 15 s
350	0.300 s / 5 s
500	- / -
600	0.100 s / 1 s

Ratings

Part Number	Current Rating	Font Color	Typ. Voltage Drop	I ² t
0298080.ZXEH-UL	80 A	Red	87 mV	-
0298100.ZXEH-UL	100 A	Yellow	87 mV	31100 A ² s
0298125.ZXEH-UL	125 A	Green	80 mV	57800 A ² s
0298150.ZXEH-UL	150 A	Orange	92 mV	100000 A ² s
0298175.ZXEH-UL	175 A	White	62 mV	168000 A ² s

UL RECOGNIZED MEGA® FUSE RATED 32V



Dimensions

Dimensions in mm

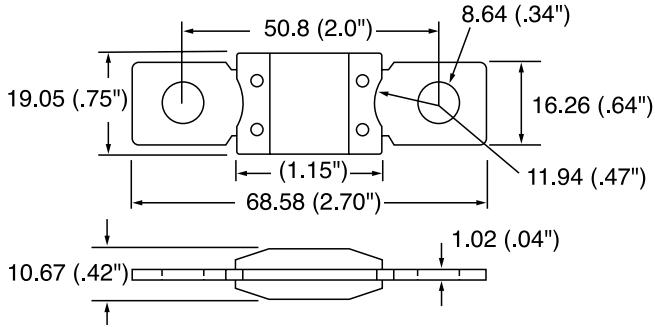

Time-Current Characteristic Curves

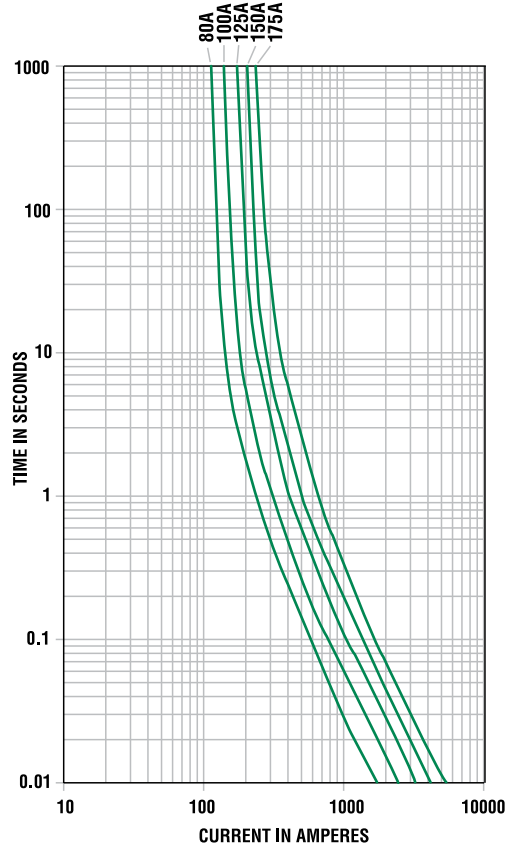

Temperature Rerating Curve

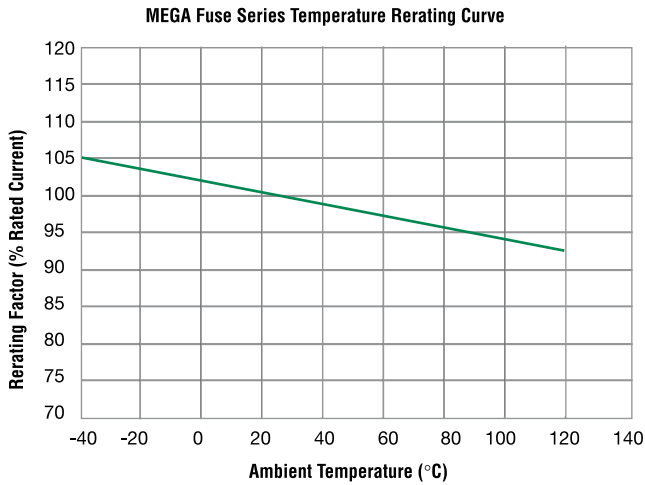

BF2 FUSE RATED 32V



Description

This BF2 fuse is rated at 32V and offers a bolt-on fuse for high current wiring protection. Current rating 100A - 500A; with transparent housing for easy detection of blown fuses.

Specifications

Housing:	Out of thermoplastic (UL 94-V0, heat-resistant) 100A - 300A: Visible melting element
Terminal:	Copper alloy, gal. Sn 2 x M8 bolts, Distance 51 mm
Mounting Torque:	12.0 Nm +/- 1Nm
Breaking Capacity:	100 A - 300 A: 2.000 A, 32V, DC 400 A - 500 A: 1.500 A, 32V, DC
Complies with:	ISO 8820-5 UL 248 Special Purpose Fuses

Ordering Information

Part Number	Package Size
153.5395.xxxx	200

Time Current Characteristics

% of Rating	Opening Time Min / Max (s)	
	100A - 250A	300A - 500A
75	- / -	4 h / -
100	4 h / -	- / -
135	120 s / 1,800 s	- / -
200	1 s / 15 s	1 s / 15 s
350	0.300 s / 5 s	0.500 s / 5 s
600	0.100 s / 1 s	0.100 s / 1 s

Ratings

Part Number	Current Rating	Housing Color	Typ. Voltage Drop	Cold Resistance	I ² t
153.5395.610_	100 A	Yellow	110 mV	0.70 mΩ	46,800 A ² s
153.5395.612_	125 A	Green	110 mV	0.52 mΩ	118,100 A ² s
153.5395.615_	150 A	Orange	110 mV	0.42 mΩ	113,400 A ² s
153.5395.617_	175 A	White	110 mV	0.36 mΩ	154,400 A ² s
153.5395.620_	200 A	Blue	110 mV	0.34 mΩ	288,000 A ² s
153.5395.622_	225 A	Brown	110 mV	0.29 mΩ	236,000 A ² s
153.5395.625_	250 A	Pink	110 mV	0.25 mΩ	292,500 A ² s
153.5395.630_*	300 A	Grey	110 mV	0.21 mΩ	486,000 A ² s
153.5395.640_*	400 A	Purple	110 mV	0.13 mΩ	964,000 A ² s
153.5395.650_*	500 A	Brown	110 mV	0.12 mΩ	1,449,000 A ² s

Last figure of article no. = packaging code
Corresponding holder see Section "Fuse Holders."
* Parts with asterisk are short circuit protectors only.

BF2 FUSE RATED 32V



Dimensions

Dimensions in mm

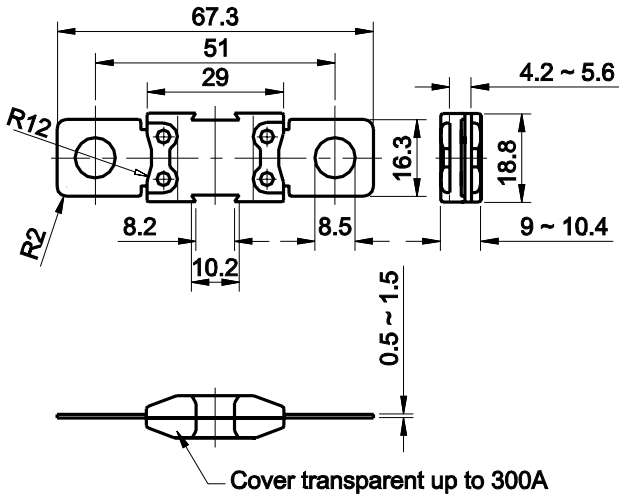

Pre-arcing Time-limits

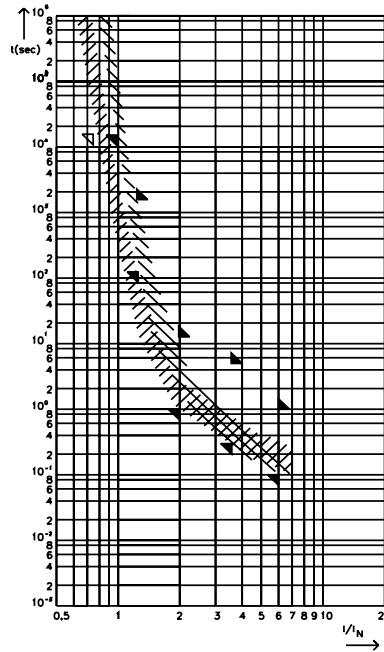

100 A - 300 A: FI = 1.25 (max. operating current: $0.8 \times I_{rat}$ at 23°C)

400 A - 500 A: FI = 2.00 (max. operating current: $0.5 \times I_{rat}$ at 23°C)

BF2 FUSE RATED 58V



Specifications

Housing:	Out of thermoplastic (UL 94-V0, heat-resistant) Visible melting element
Terminal:	Copper alloy, gal. Sn 2 x M8 bolts, Distance 51 mm
Mounting Torque:	12.0 Nm +/- 1Nm
Breaking Capacity:	1000A, 58V DC
Complies with:	ISO 8820-5 UL 248 Special Purpose Fuses

Ordering Information

Part Number	Package Size
142.5395.xxx2	200









Description

This BF2 fuse is rated at 58V and offers a bolt-on fuse for high current wiring protection. Current rating 100A - 300A; with transparent housing for easy detection of blown fuses.

Time-Current Characteristics

% of Rating	Opening Time Min / Max (s)	
	100A - 250A	300A
75	- / -	- / -
100	4 h / -	4 h / -
135	120 s / 1,800 s	- / -
200	1 s / 15 s	1 s / 15 s
350	0.300 s / 5 s	0.500 s / 5 s
600	0.100 s / 1 s	0.100 s / 1 s

Ratings

Part Number	Current Rating	Housing Color	Typ. Voltage Drop	Cold Resistance	I ² t
142.5395.6102	100 A		110 mV	0.70 mΩ	46,800 A ² s
142.5395.6122	125 A		110 mV	0.52 mΩ	118,100 A ² s
142.5395.6152	150 A		110 mV	0.42 mΩ	113,400 A ² s
142.5395.6172	175 A		110 mV	0.36 mΩ	154,400 A ² s
142.5395.6202	200 A		110 mV	0.34 mΩ	288,000 A ² s
142.5395.6222	225 A		110 mV	0.29 mΩ	236,000 A ² s
142.5395.6252	250 A		110 mV	0.25 mΩ	292,500 A ² s
142.5395.6302 ¹	300 A		110 mV	0.21 mΩ	486,000 A ² s

Note 1: Short circuit protectors only.

BF2 FUSE RATED 58V



Dimensions

Dimensions in mm

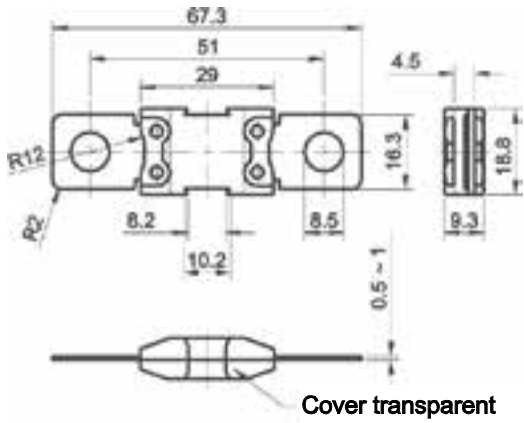

Pre-Arcing Time-Limits

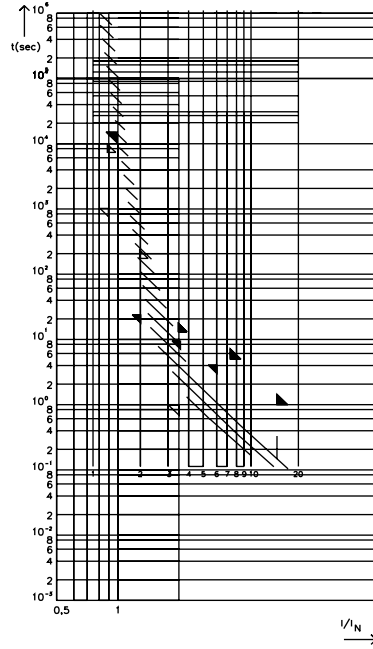

FI = 1.25 (max. operating current: $0.8 \times I_{rat}$ at 23°C)

FUSE STRIPS FOR DIESEL RATED 36V

RoHS



Description

Non-housed fuse strips for Diesel vehicles.
Current rating 25A - 150A, 36 VDC. 90° fork type lugs.

Dimensions

Dimensions in mm

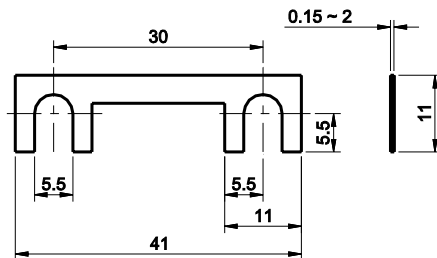

Ratings

Part Number	Current Rating	Typ. Voltage Drop
156.5610.525_	25 A*	70 mV
156.5610.530_	30 A	70 mV
156.5610.540_	40 A*	70 mV
156.5610.550_	50 A	70 mV
156.5610.560_	60 A*	70 mV
156.5610.570_	70 A*	70 mV
156.5610.580_	80 A	70 mV
156.5610.610_	100 A	70 mV
156.5610.611_	120 A*	70 mV
156.5610.612_	125 A*	70 mV
156.5610.615_	150 A*	70 mV
156.5610.625_	250A*	70 mV

Specifications

Metal Parts: Zinc-alloy
Complies with: DIN 72581/2

Ordering Information

Part Number	Package Size
156.5610.xxx1	100
156.5610.xxx2	2000

Pre-arcing Time-limits

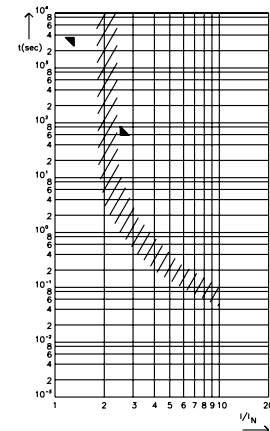

FI = 1.00 (max. operating current: $1.0 \times I_{rat}$ at 23°C)

Time-Current Characteristics

% of Rating	Opening Time Min / Max (s)
130	3,600 s / -
250	- / 60 s

*Not mentioned in the standards
Corresponding holder see Section "Fuse Holders."

FUSE STRIPS WITH HOUSING RATED 80V

RoHS



Description

Housed fuse strips with window for visual inspection of melting element. Current rating 30A - 150A, 80 VDC. 90° fork type lugs.

Dimensions

Dimensions in mm

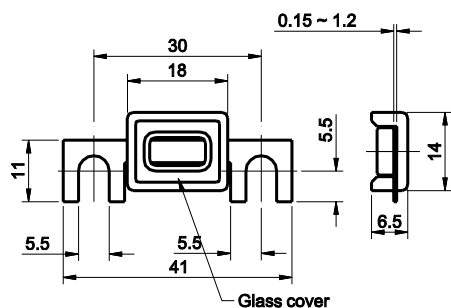

Ratings

Part Number	Current Rating	Typ. Voltage Drop
156.5611.5301	30 A*	70 mV
156.5611.5401	40 A*	70 mV
156.5611.5501	50 A*	70 mV
156.5611.5601	60 A*	70 mV
156.5611.5701	70 A*	70 mV
156.5611.5801	80 A*	70 mV
156.5611.6101	100 A*	70 mV
156.5611.6111	120 A*	70 mV
156.5611.6121	125 A*	70 mV
156.5611.6151	150 A*	70 mV

Specifications

Insulating Body:	Out of ceramic
Metal Parts:	Zinc-alloy
Complies with:	DIN 72581/2
Complies with:	UL 248 Special Purpose Fuses

Ordering Information

Part Number	Package Size
156.5611.xxx1	50

Pre-Arcing Time-Limits

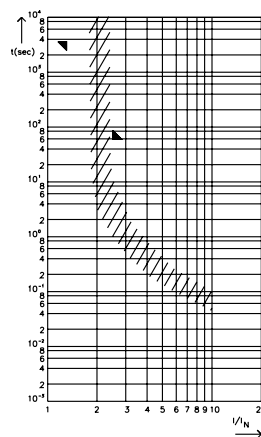

FI = 1.00 (max. operating current : 1.0 x I_{rat} at 23°C)

Time-Current Characteristics

% of Rating	Opening Time Min / Max (s)
130	3,600 s / -
250	- / 60 s

Corresponding holder see Section "Fuse Holders."

*Metal parts in compliance with DIN 7258½. Fuses with housings not mentioned in the standards.

FUSE STRIPS FOR BATTERY-POWERED VEHICLES RATED 80V

RoHS



Description

Non-housed fuse strips for battery powered fuses.
Current rating 25A - 150A, 36 VDC. 90° fork type lugs.

Dimensions

Dimensions in mm

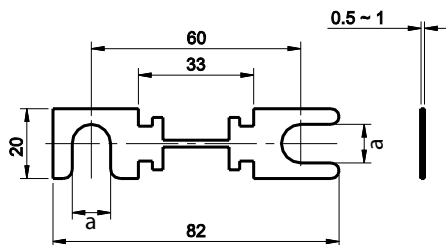

Ratings

Part Number		Current Rating	Typ. Voltage Drop	Breaking Capacity
a = 11 mm	a = 9 mm*			
157.5700.5351	157.5916.5351*	35 A	125 mV	48VDC/210A
157.5700.5401*	-	40 A	125 mV	48VDC/240A
157.5700.5501	157.5916.5501*	50 A	125 mV	48VDC/300A
157.5700.5631	157.5916.5631*	63 A	125 mV	48VDC/378A
157.5700.5801	157.5916.5801*	80 A	125 mV	48VDC/480A
157.5700.6101	157.5916.6101*	100 A	125 mV	48VDC/600A
157.5700.6121	157.5916.6121*	125 A	125 mV	48VDC/750A
157.5700.6131	157.5916.6131*	130 A	125 mV	48VDC/780A
157.5700.6141*	-	135 A	125 mV	48VDC/810A
157.5700.6151*	-	150 A	125 mV	48VDC/900A
157.5700.6161	157.5916.6161*	160 A	125 mV	48VDC/960A
157.5700.6171*	-	175 A	125 mV	48VDC/1050A
157.5700.6201	157.5916.6201*	200 A	125 mV	48VDC/1200A
157.5700.6231*	-	225 A	125 mV	48VDC/1350A
157.5700.6251	157.5916.6251*	250 A	125 mV	48VDC/1500A
157.5700.6271*	-	275 A	125 mV	48VDC/1650A
157.5700.6301	-	300 A	125 mV	48VDC/1800A
157.5700.6331*	-	325 A	125 mV	48VDC/1950A
157.5700.6351	-	355 A	125 mV	48VDC/2130A
157.5700.6401*	-	400 A	125 mV	48VDC/2400A
157.5700.6421	-	425 A	125 mV	48VDC/2550A
157.5700.6501*	-	500 A	125 mV	48VDC/3000A

* Not mentioned in the standards. Corresponding holders = 177.5701.0001 and 177.5702.0001."

Specifications

Metal Parts: 35 A - 80 A: Zinc-alloy
100A - 425 A: Copper Cu, gal. Sn
Complies with: UL 248 Special Purpose Fuses

Ordering Information

Part Number	Package Size
157.5700.xxx1	50
157.5916.xxx1	50

Time-Current Characteristics

% of Rating	Opening Time Min / Max (s)	
	35-200	225 - 425
150	3,600 s / -	- / -
160	- / -	60 s / -
220	- / 60 s	
250	0.8 s / 10 s	
400	0.25 / 2 s	

Pre-Arcing Time-Limits

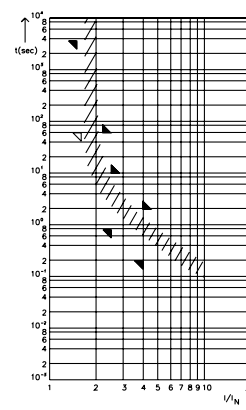

FI = 1.00 (max. operating current: 1.0 x I_{rat} at 23°C)

FUSE STRIPS WITH HOUSING FOR BATTERY-POWERED VEHICLES RATED 80V



Specifications

Metal Parts: 35A - 80A: Zinc-alloy
 100A - 425A: Copper Cu, gal. Sn
 Complies with: UL 248 Special Purpose Fuses
 cULus Recognized: File No. E211637

Ordering Information

Part Number	Package Size
157.5701.xxx1	50
157.5917.xxx1	50

Time-Current Characteristics

% of Rating	Opening Time Min / Max (s)	
	35-200	225 - 425
150	3,600 s / -	- / -
160	- / -	60 s / -
220	- / 60 s	
250	0.8 s / 10 s	
400	0.25 / 2 s	

Description

Housed fuse strips for battery-powered vehicles. Current rating 35A - 500A, 80 VDC. 90° and straight fork type lugs. With window for visual inspection of melting element.

Dimensions

Dimensions in mm

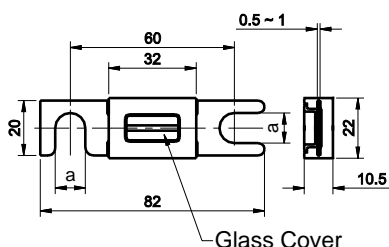

Ratings

Part Number		Current Rating	Typ. Voltage Drop	Breaking Capacity
a = 11 mm	a = 9 mm*			
157.5701.5351	157.5917.5351*	35 A	125 mV	48VDC/210A
157.5701.5401*	-	40 A	125 mV	48VDC/240A
157.5701.5501	157.5917.5501*	50 A	125 mV	48VDC/300A
157.5701.5631	157.5917.5631*	63 A	125 mV	48VDC/378A
157.5701.5801	157.5917.5801*	80 A	125 mV	48VDC/480A
157.5701.6101	157.5917.6101*	100 A	125 mV	48VDC/600A
157.5701.6121	157.5917.6121*	125 A	125 mV	48VDC/750A
157.5701.6131*	-	130 A	125 mV	48VDC/780A
157.5701.6141*	-	135 A	125 mV	48VDC/810A
157.5701.6151*	157.5917.6151*	150 A	125 mV	48VDC/900A
157.5701.6161	157.5917.6161*	160 A	125 mV	48VDC/960A
157.5701.6171*	157.5917.6171*	175 A	125 mV	48VDC/1050A
157.5701.6201	157.5917.6201*	200 A	125 mV	48VDC/1200A
157.5701.6231*	157.5917.6231*	225 A	125 mV	48VDC/1350A
157.5701.6251	157.5917.6251*	250 A	125 mV	48VDC/1500A
157.5701.6271*	157.5917.6281*	275 A	125 mV	48VDC/1650A
157.5701.6301	-	300 A	125 mV	48VDC/1800A
157.5701.6331*	157.5917.6331*	325 A	125 mV	48VDC/1950A
157.5701.6351	157.5917.6351*	355 A	125 mV	48VDC/2130A
157.5701.6401*	-	400 A	125 mV	48VDC/2400A
157.5701.6421	157.5917.6421*	425 A	125 mV	48VDC/2550A
157.5701.6501*	157.5917.6501*	500 A	125 mV	48VDC/3000A

Pre-Arcing Time-Limits

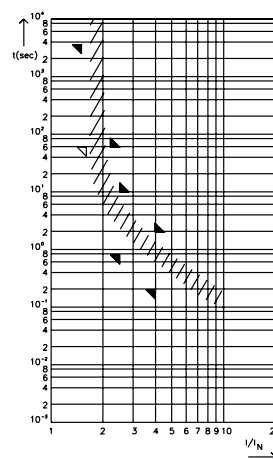

FI = 1.00 (max. operating current: 1.0 x I_{rat} at 23°C)

*Not mentioned in the standards.

Corresponding holder see Section "Fuse Holders."

HSB FUSE RATED 32V

RoHS



Description

Non-housed fuse strips for rated voltage up to 32 VDC. Current rating 30 A -175 A. Ring type lugs.

Dimensions

Dimensions in mm

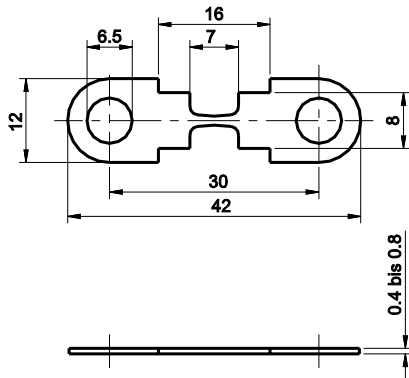

Specifications

Material: Zinc-alloy
 Connections: Zinc-alloy
 2 x M6 bolts, distance 30 mm
 Starting Torque: 4 Nm +/- 1 Nm

Ordering Information

Part Number	Package Size
156.5677.xxx1	100
156.5677.xxx2	10000

Pre-Arcing Time-Limits

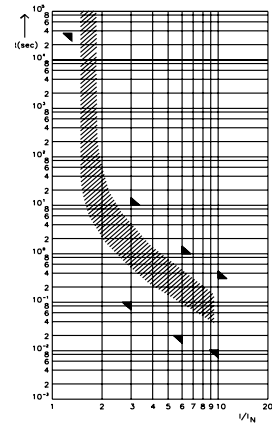

FI = 1.00 (max. operating current: $1.0 \times I_{rat}$ at 23°C)

Time-Current Characteristics

% of Rating	Opening Time Min / Max (s)
100	∞ / -
125	360,000 s / -
300	0.100 s / 10 s
600	0.020 s / 1 s
1000	0.010 s / 0.300 s

Ratings

Part Number	Current Rating	Typ. Voltage Drop	Cold Resistance	I ² t
156.5677.530_	30 A	44mV	1.33 mΩ	3800 A ² s
156.5677.540_	40 A	40mV	0.89 mΩ	11200 A ² s
156.5677.550_	50 A	44mV	0.72 mΩ	21300 A ² s
156.5677.560_	60 A	38mV	0.58 mΩ	41400 A ² s
156.5677.580_	80 A	40mV	0.43 mΩ	44800 A ² s
156.5677.611_	110 A	40mV	0.31 mΩ	139000 A ² s
156.5677.615_	150 A	52mV	0.23 mΩ	465000 A ² s
156.5677.617_	175 A	46mV	0.22 mΩ	560000 A ² s

Corresponding holder see Section "Fuse Holders."

CF FUSE RATED 58V



Description

Main Fuse for mounting with battery clamp on the battery pole. Voltage rating 58 VDC, Current rating 50A - 300A. With transparent cover for visual inspection of melting element.

Dimensions

Dimensions in mm

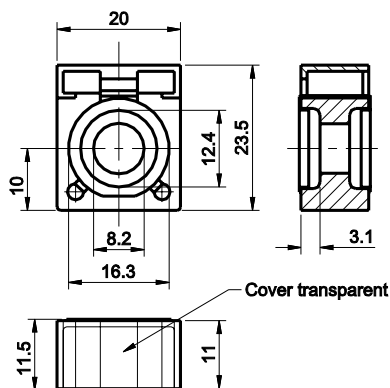

Ratings

Part Number	Current Rating	Typ. Voltage Drop	Cold Resistance	I ² t
155.0892.5501	50 A	100 mV	1.20 mΩ	1,900 A ² s
155.0892.5751	75 A	90 mV	0.60 mΩ	12,000 A ² s
155.0892.6101	100 A	80 mV	0.60 mΩ	14,000 A ² s
155.0892.6121	125 A	75 mV	0.45 mΩ	51,000 A ² s
155.0892.6151	150 A	70 mV	0.35 mΩ	63,800 A ² s
155.0892.6171	175 A	70 mV	0.25 mΩ	120,000 A ² s
155.0892.6201	200 A	65 mV	0.25 mΩ	172,800 A ² s
155.0892.6251	250 A	70 mV	0.20 mΩ	330,000 A ² s
155.0892.6301	300 A	70 mV	0.15 mΩ	372,000 A ² s

Insert CF8-Fuse links only in conjunction with the insulating nuts, see Section "Fuse Holders." Corresponding battery clamp see Section "Fuse Holders."

Specifications

Insulating Body:	Out of ceramic
Cover:	Out of thermoplast (UL 94-V0, heat resistant)
Visible melting-element	
Interrupting Rating:	2,000A @58 VDC
Complies with:	ISO 8820-6 DIN 72581-5
cULus Recognized:	UL 248 Special Purpose Fuses File No. E211637

Ordering Information

Part Number	Package Size
155.0892.xxx1	100

Pre-Arcing Time-Limits

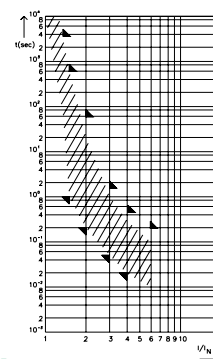

FI = 1.25 (max. operating current:
0.8 x I_{rat} at 23°C)

Time-Current Characteristics

% of Rating	Opening Time Min / Max (s)
100	360,000 s / -
135	- / 3,600 s
150	1 s / 600 s
200	0.200 s / 60 s
300	0.050 s / 1.5 s
400	0.020 s / 0.50 s
600	- / 0.20 s

Cable Fuses



CABLEPRO® Cable Protector Fuses Rated 32V	74
BF-Inline Fuses Rated 32V	75

CABLEPRO® CABLE PROTECTOR FUSES RATED 32V

Available in AWG and metric cables

RoHS



Specifications

Voltage Rating:	32 VDC
Cable Types Available:	SAE J1127 STX , SAE J1128 TXL , ISO6722: Type FL2G
Interrupting Rating:	2000A @ 32 VDC
Operating Temperature Range:	-40°C to + 125°C

Available with UL recognized in 60A, 100A, 150A, 200A at 32V

Dimensions

Dimensions in mm

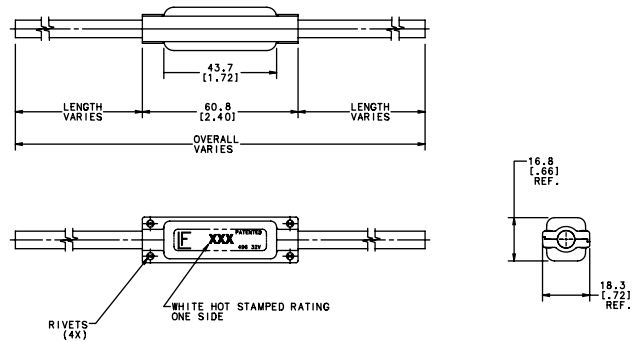

Description

The CABLEPRO® fuse is designed to replace conventional wire fusible links in high current automotive applications. The slim package of the CABLEPRO® and the predictable and reliable performance characteristics (similar to MEGA® fuse) make this far superior over wire fusible links. Interrupting rating 2000A @ 32 VDC. CablePro is not a sealed product. To seal it a shrink tube should be used.

Time-Current Characteristics

% of Rating	Opening Time Min / Max (s)
100	360,000 s / -
135	120 s / 1800 s
200	10 s / 300 s
350	1 s / 15 s
600	0.30 s / 5 s

Ratings

Part Number	Current Rating	Wire Size	Cold Resistance	I²t
0496060_1	60 A	5mm ² (10AWG)	0.920 mΩ	-
0496080_	80 A	8mm ² (8AWG)	0.689 mΩ	-
0496100_1	100 A	8mm ² (8AWG)	0.460 mΩ	-
0496125_	125 A	13mm ² (6AWG)	0.390 mΩ	-
0496150_1	150 A	19mm ² (4AWG)	0.346 mΩ	-
0496175_	175 A	19mm ² (4AWG)	0.268 mΩ	-
0496200_1	200 A	19mm ² (4AWG)	0.173 mΩ	-
0496200_1	200 A	25mm ²	-	-

Note 1: UL Recognized CablePro
Contact Littelfuse for complete part numbers.

BF-INLINE FUSE RATED 32V

RoHS



Description

Inline fuse to protect specific cable cross-sections and insulations; Cross-section 10mm² to 35mm². For rated voltage up to 32 VDC.

Assembly notes: The wire integrated fuse has to be insulated by using a self-adhesive shrinking tube. The wire has to be fixed on both sides of the fuse to minimize the wire forces. Recommended shrinking tube: DERAY(R)-IAKT 4:1, 24mm

Pre-Arcing Time-Limits

FI = 1,25 (max. operating current: 0,8 x I_{rat} at 23°C)

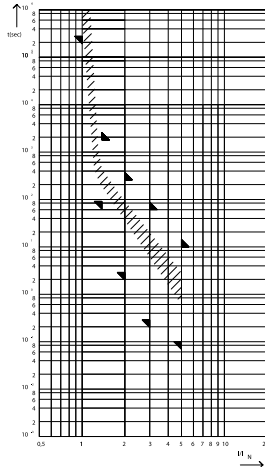

Ratings

Part Number	Current Rating	Wire Size/Type/Marking	Typ. Voltage Drop	Cold Resistance	I ² t
153.1002	100 A	10mm ² /FLY/P	60 mV	0.42 mΩ	26.000 A ² s
153.1012	125 A	10mm ² /FL2G/S	70 mV	0.32 mΩ	86.000 A ² s
153.1602	125 A	16mm ² /FLY/P	75 mV	0.41 mΩ	28,000 A ² s
153.1612	170 A	16mm ² /FL2G/S	60 mV	0.22 mΩ	250,000 A ² s
153.2502	170 A	25mm ² /FLY/P	70 mV	0.29 mΩ	75,000 A ² s
153.2512	190 A	25mm ² /FL2G/S	52 mV	0.18mΩ	610,000 A ² s
153.3502	300 A	35mm ² /FLY/P	70 mV	0.20 mΩ	589.500 A ² s

Specifications

Voltage Rating: 32 VDC
 Housing: Out of thermoplastic heat-resistant
 Terminals: Crimp, Copper alloy, tinned
 Interrupting Rating: 2000A @32VDC

Ordering Information

Part Number	Package Size
153.xxxx	300

Time-Current Characteristics 100A-190A

% of Rating	Opening Time Min / Max (s)	
100	360,000 s	–
165	10 s	100 s
200	3 s	240 s
300	0.3 s	60 s
500	0.1 s	10 s

Time-Current Characteristics 300A

% of Rating	Opening Time Min / Max (s)	
75	360,000 s	–
165	10 s	100 s
200	1 s	15 s
350	0.3 s	5 s
500	0.1 s	1 s

LC HEV FUSE

RoHS



Specifications

Interrupting Rating (10A, 20A, 30A, 40A):	10kA @ 450 VDC
Interrupting Rating (40A):	10kA @ 425 VDC
Voltage Rating (10A, 15A, 20A, 30A):	450 VDC
Voltage Rating (40A):	425 VDC
Operating Temperature Range:	-40°C to +125°C

Ordering Information

Part Number	Termination	Package Size
OHEVxxx.SXC	Cartridge	36
OHEVxxx.SXBD	Bolt Down	20
OHEVxxx.SXBDY	Blade	20

Description

The LC HEV fuse is designed for protection of high-voltage accessory circuits in electric and hybrid electric vehicles.

Time-Current Characteristics

% of Rating	Opening Time Min / Max (s) 10A	Opening Time Min / Max (s) 15A, 20A, 30A	Opening Time Min / Max (s) 40A
100	100 hrs / -	100 hrs / -	100 hrs / -
110	4 hrs / -	4 hrs / -	-
135	100 / 3600	150 / 3600	150 / 3600
150	10 / 1000	10 / 1000	10 / 1000
200	0.5 / 100	0.5 / 100	0.5 / 100
300	0.1 / 15	0.1 / 15	0.1 / 15
500	0.05 / 1	0.05 / 1	0.05 / 1

Ratings

Part Number	Current Rating	Color Code	Typical Voltage Drop at 70% I _R	Maximum Voltage Drop Spec at 100% IR	Cold Resistance	Minimum Melting I ² t
OHEV010.xxx	10A	Red	114 mV	300 mV	13.3 mOhm	255 A ² s
OHEV015.xxx	15A	Blue	96 mV	200 mV	7.9 mOhm	133 A ² s
OHEV020.xxx	20A	Yellow	79 mV	200 mV	6.4 mOhm	268 A ² s
OHEV030.xxx	30A	Green	67 mV	200 mV	2.7 mOhm	993 A ² s
OHEV040.xxx	40A	Orange	69 mV	200 mV	1.3 mOhm	1495 A ² s

Average Initial Measurements

LC HEV FUSE

RoHS

Time-Current Characteristic Curves

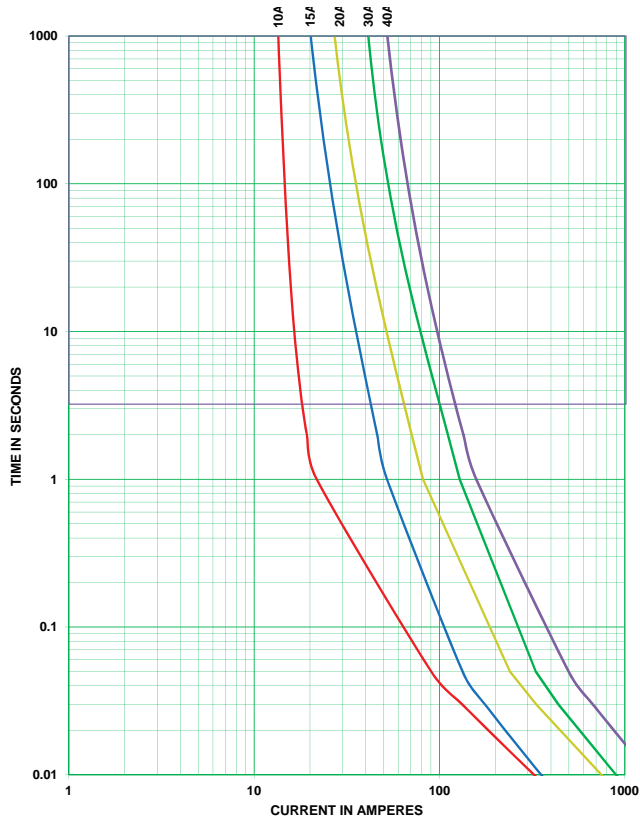

Dimensions

Dimensions in mm

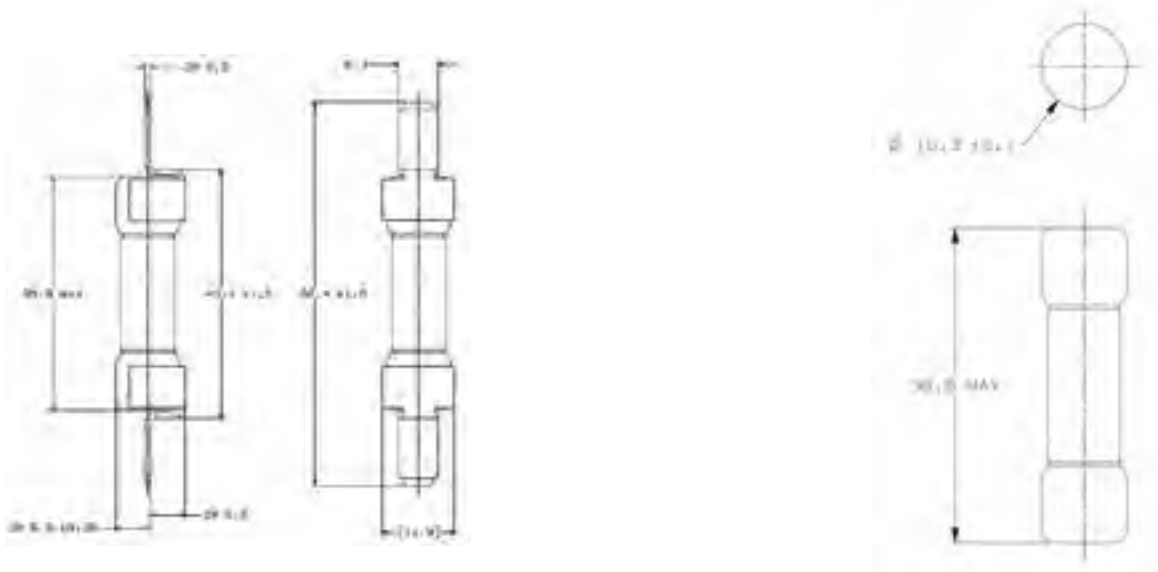
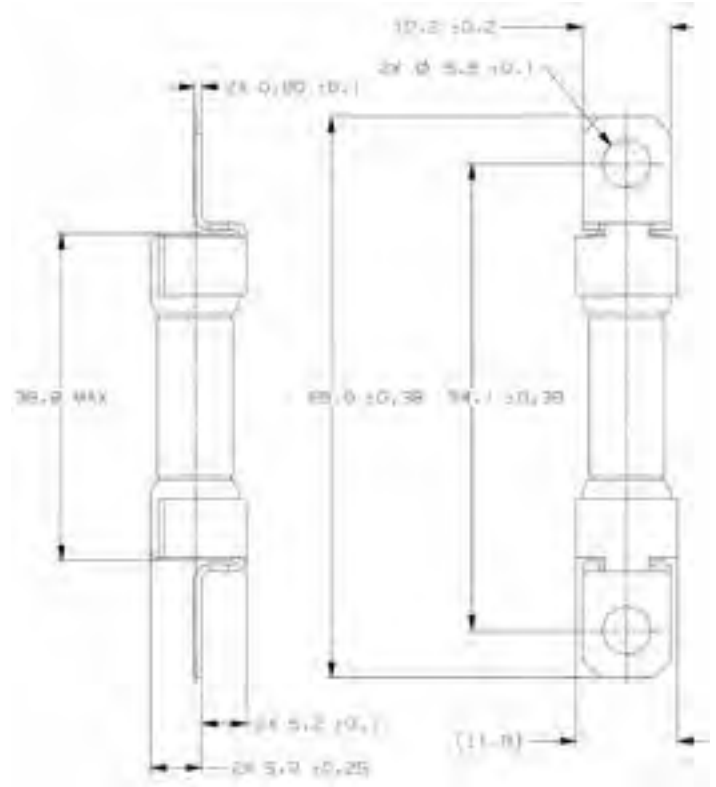

LC HEV FUSE

RoHS



Specifications

Voltage Rating (50A):	250 VAC
Interrupting Rating (50A):	2,000A @ 250 VAC
Operating Temperature Range:	-40°C to +125°C

Ordering Information

Part Number	Termination	Package Size
0HEVxxx.SXBD2	Bolt Down	20
0HEVxxx.SXBD2Y	Blade	20

Description

The LC HEV fuse is designed for protection of high-voltage accessory circuits in electric and hybrid electric vehicles.

Time-Current Characteristics

% of Rating	Opening Time Min / Max (s)
100	100 hrs / -
110	4 hrs / -
135	-
150	-
200	0.5 / 100
300	0.1 / 15
500	0.05 / 1

Ratings

Part Number	Current Rating	Voltage Rating	Color Code	Typical Voltage Drop at 70% I _R	Maximum Voltage Drop Spec at 100% I _R	Cold Resistance	Minimum Melting I ² t
0HEV050.XXXX	50A	250 VAC		57 mV	200 mV	1.30 mOhm	1495 A ² s

Average Initial Measurements

MASTERFUSE

RoHS



Description

The Masterfuse product is a configurable fuse solution combining several different fuse types (i.e. MEGA and MIDI) and ratings in one compact package. This fuse package allows the user to replace multiple discrete fuses in a power distribution box with a single component, thus eliminating additional bolts, bus bars, and interconnects that are currently used. By reducing the number of connections required, overall system reliability is increased while cost is decreased.

Each Masterfuse is customized to the user's application creating an optimized circuit protection package. Contact Littelfuse to review your application needs.

Specifications

Mating Terminal Options:	M10, M8, M6, M5 bolt-down connections or female terminals
Operating Temperature Range:	-40°C to 125°C
Fuse Ratings Available:	30-500A
Voltage Rating:	32Vdc
Materials:	Copper terminals (silver or tin plating options available)
Complies with:	ISO 8820-5

Features and Benefits

Increased Reliability:	due to reduced number of terminal interfaces
System Cost Savings:	Material savings due to reduced number of components required. Assembly cost savings due to reduced number of operations required for installation.
Fuse Array Customization:	Ability to mix different fuse types (i.e. MEGA, MIDI, etc.) in one compact package
Termination Options:	Ability to mate to female terminals to enable "bolt-less" design
Marking:	Custom marking options available



PAL Fuses



Auto Link PAL Fuses - 293	83
Auto Link PAL Fuses - 2935	84
Auto Link PAL Fuses - 2938	85
Auto Link PAL Fuses - 294	86
Auto Link PAL Fuses - 294C	87
Auto Link PAL Fuses - 295	88
Auto Link PAL Fuses - 283B	89
Auto Link PAL Fuses - 283	90

AUTO LINK PAL FUSES - 293

RoHS



Description

PAL fuses are commonly found on many Japanese and domestic built vehicles.

Specifications

Voltage Rating: 32 VDC
 Current Cycling: 24°C
 The fuses satisfy the performance requirements after 50% of the rated current is applied for 10,000 cycles. Each cycle consists of an interrupted current with the pattern of 5 minutes ON and 10 minutes OFF.
 Operating Temperature Range: -40°C to +125°C

Complies with JASO 0612

Ordering Information

Part Number	Package Size
0293xxx.H	100
0293xxx.U	500
0293xxx.MXJ	1000

Time-Current Characteristics

% of Rating	Opening Time Min / Max (s)
110	14,400 s
200	5 s / 100 s
350	0.2s / 7 s
600	0.040 s / 1 s

Ratings

Part Number	Current Rating (A)	Body Color
0293020._	20	LIGHT BLUE
0293030._	30	PINK
0293040._	40	GREEN
0293050._	50	RED
0293060._	60	YELLOW
0293070._	70	BROWN
0293080._	80	BLACK
0293100._	100	BLUE

Dimensions

Dimensions in mm

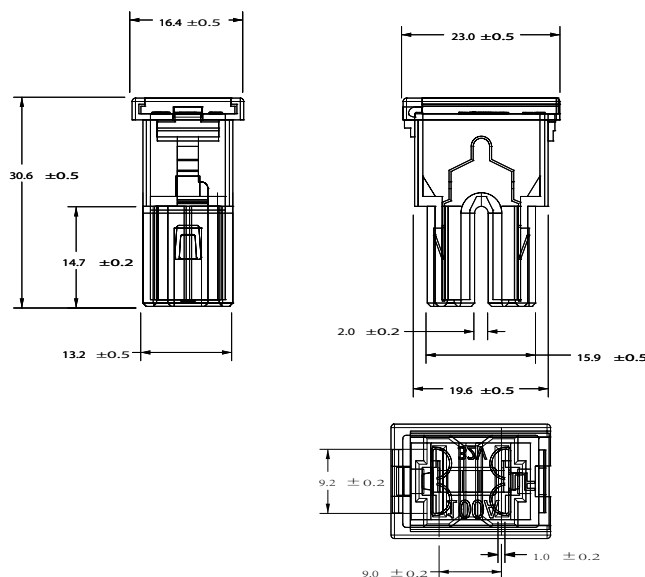

AUTO LINK PAL FUSES - 2935

RoHS



Description

PAL fuses are commonly found on many Japanese and domestic built vehicles.

Ratings

Part Number	Current Rating (A)	Body Color
0293525._	25	LIGHT BROWN
0293530._	30	LIGHT GREEN
0293545._	45	RED
0293565._	65	BLACK
0293575._	75	GRAY

Dimensions (25A - 30A)

Dimensions in mm

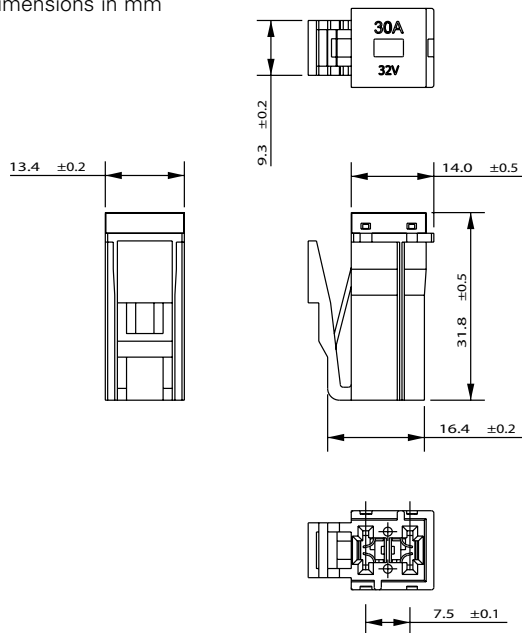

Specifications

Voltage Rating: 32 VDC
 Current Cycling: 24°C
 The fuses satisfy the performance requirements after 50% of the rated current is applied for 10,000 cycles. Each cycle consists of an interrupted current with the pattern of 5 minutes ON and 10 minutes OFF.
 Operating Temperature Range: -40°C to +125°C

Complies with JASO 0612

Ordering Information

Part Number	Package Size
02935xx.H	100
02935xx.U	500
02935xx.MXJ	1000

Time-Current Characteristics

% of Rating	Opening Time Min / Max (s)	
	25A - 30A	45A - 75A
110	- / -	14,400 s
150	- / -	100 s
200	5 s / 70 s	2 s / 60 s
300	- / 6 s	- / 5 s
600	- / 3 s	- / 2 s

Dimensions (45A - 75A)

Dimensions in mm

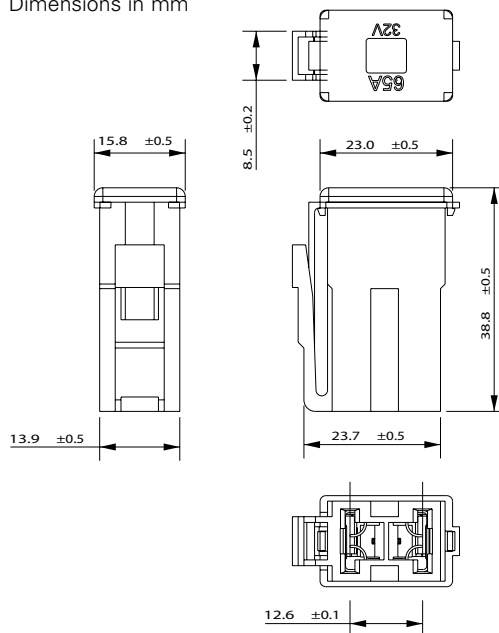

AUTO LINK PAL FUSES - 2938

RoHS



Description

PAL fuses are commonly found on many Japanese and domestic built vehicles.

Specifications

Voltage Rating: 32 VDC
 Current Cycling: 24°C
 The fuses satisfy the performance requirements after 50% of the rated current is applied for 10,000 cycles. Each cycle consists of an interrupted current with the pattern of 5 minutes ON and 10 minutes OFF.
 Operating Temperature Range: -40°C to +125°C

Complies with JASO 0612

Ordering Information

Part Number	Package Size
02938xxx.H	100
02938xxx.U	500
02938xxx.MXJ	1000

Time-Current Characteristics

% of Rating	Opening Time Min / Max (s)
110	14,400 s
200	5 s / 100 s
350	0.2s / 7 s
600	0.040 s / 1 s

Ratings

Part Number	Current Rating (A)	Body Color
0293820_	20	LIGHT BLUE
0293830_	30	PINK
0293840_	40	GREEN
0293850_	50	RED
0293860_	60	YELLOW
0293870_	70	BROWN
0293880_	80	BLACK

Dimensions

Dimensions in mm

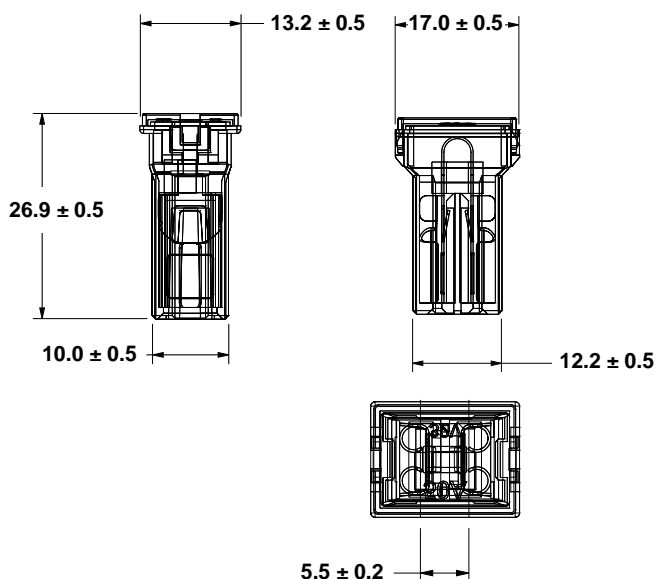

AUTO LINK PAL FUSES - 294

RoHS

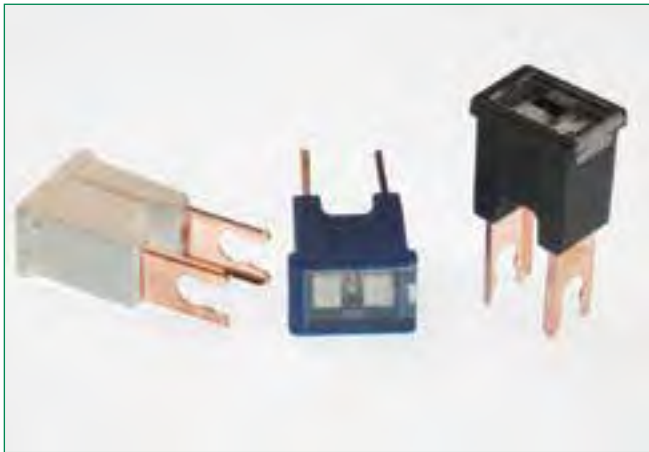

Description

PAL fuses are commonly found on many Japanese and domestic built vehicles.

Specifications

Voltage Rating: 32 VDC
 Current Cycling: 24°C
 The fuses satisfy the performance requirements after 50% of the rated current is applied for 10,000 cycles. Each cycle consists of an interrupted current with the pattern of 5 minutes ON and 10 minutes OFF.
 Operating Temperature Range: -40°C to +125°C

Complies with JASO 0612

Ordering Information

Part Number	Package Size
0294xxx.H	100
0294xxx.U	500
0294xxx.MXJ	1000

Time-Current Characteristics

% of Rating	Opening Time Min / Max (s)
110	14,400 s
200	5 s / 100 s
350	0.2s / 7 s
600	0.040 s / 1 s

Ratings

Part Number	Current Rating (A)	Body Color
0294030_	30	PINK
0294040_	40	GREEN
0294050_	50	RED
0294060_	60	YELLOW
0294070_	70	BROWN
0294080_	80	BLACK
0294100_	100	BLUE
0294120_	120	WHITE

Dimensions

Dimensions in mm

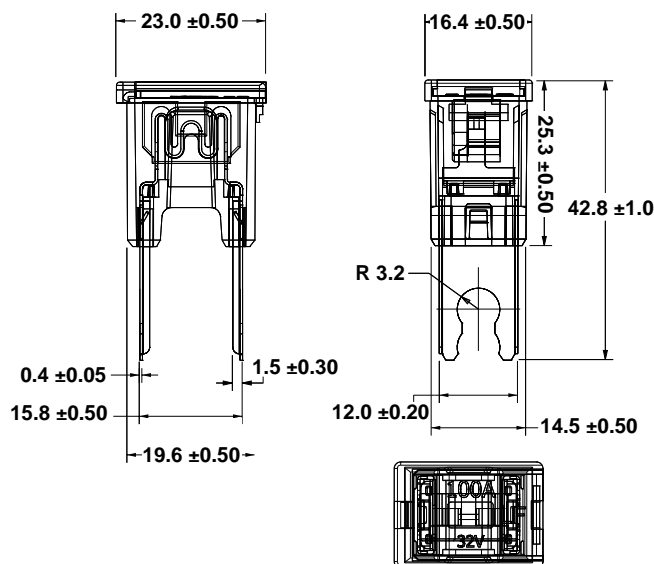

AUTO LINK PAL FUSES - 294C

RoHS



Description

PAL fuses are commonly found on many Japanese and domestic built vehicles.

Specifications

Voltage Rating: 32 VDC
 Current Cycling: 24°C
 The fuses satisfy the performance requirements after 50% of the rated current is applied for 10,000 cycles. Each cycle consists of an interrupted current with the pattern of 5 minutes ON and 10 minutes OFF.
 Operating Temperature Range: -40°C to +125°C

Complies with JASO 0612

Ordering Information

Part Number	Package Size
0294xxx.MXJ-C	1000

Time-Current Characteristics

% of Rating	Opening Time Min / Max (s)
110	14,400 s
200	5 s / 100 s
350	0.2s / 7 s
600	0.040 s / 1 s

Ratings

Part Number	Current Rating (A)	Body Color
0294020_	20	LIGHT BLUE
0294030_	30	PINK
0294040_	40	GREEN
0294050_	50	RED
0294060_	60	YELLOW
0294070_	70	BROWN
0294080_	80	BLACK
0294100_	100	BLUE
0294120_	120	WHITE

Dimensions

Dimensions in mm

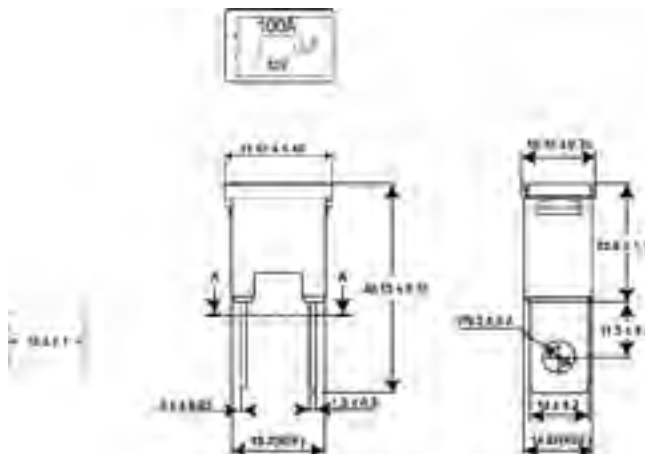

AUTO LINK PAL FUSES - 295

RoHS

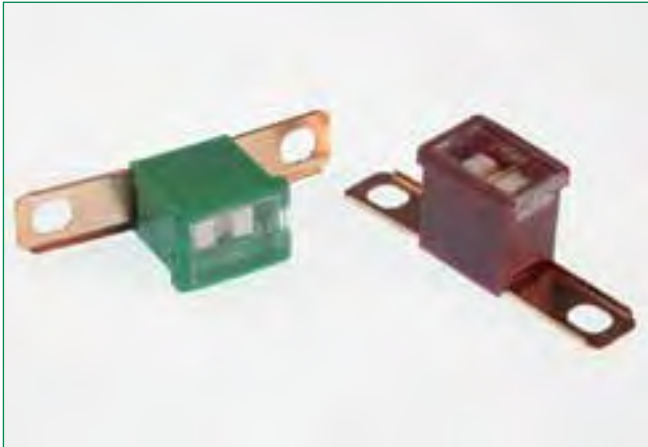

Description

PAL fuses are commonly found on many Japanese and domestic built vehicles.

Specifications

Voltage Rating: 32 VDC
 Current Cycling: 24°C
 The fuses satisfy the performance requirements after 50% of the rated current is applied for 10,000 cycles. Each cycle consists of an interrupted current with the pattern of 5 minutes ON and 10 minutes OFF.
 Operating Temperature Range: -40°C to +125°C

Complies with JASO 0612

Ordering Information

Part Number	Package Size
0295xxx.H	100
0295xxx.U	500
0295xxx.MXJ	1000

Time-Current Characteristics

% of Rating	Opening Time Min / Max (s)
110	14,400 s
200	5 s / 100 s
350	0.2s / 7 s
600	0.040 s / 1 s

Ratings

Part Number	Current Rating (A)	Body Color
0295020._	20	LIGHT BLUE
0295030._	30	PINK
0295040._	40	GREEN
0295050._	50	RED
0295060._	60	YELLOW
0295070._	70	BROWN
0295080._	80	BLACK
0295100._	100	BLUE
0295120._	120	WHITE
0295140._	140	REDDISH BROWN

Dimensions

Dimensions in mm

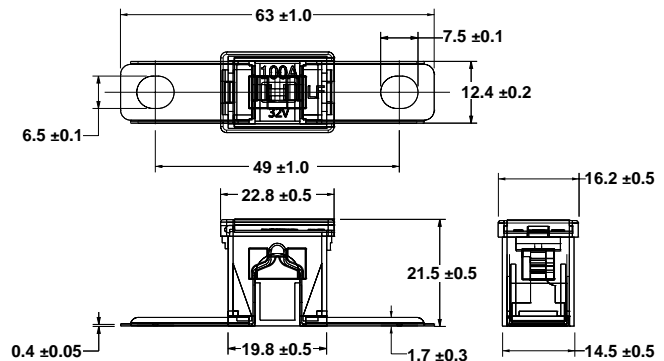

AUTO LINK PAL FUSES - 283B

RoHS

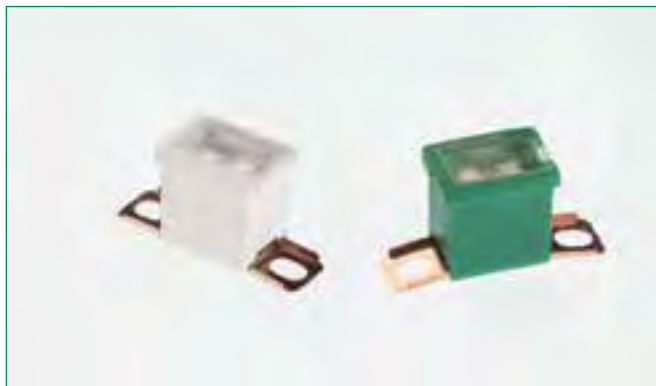

Specifications

Voltage Rating: 32 VDC
 Current Cycling: 24°C
 The fuses satisfy the performance requirements after 50% of the rated current is applied for 10,000 cycles. Each cycle consists of an interrupted current with the pattern of 5 minutes ON and 10 minutes OFF.
 Operating Temperature Range: -40°C to +125°C

Complies with JASO 0612

Ordering Information

Part Number	Package Size
0283xxx.MXJ-B	1000

Description

PAL fuses are commonly found on many Japanese and domestic built vehicles.

Time-Current Characteristics

% of Rating	Opening Time Min / Max (s)
110	14,400 s
200	5 s / 100 s
350	0.2s / 7 s
600	0.040 s / 1 s

Ratings

Part Number	Current Rating (A)	Body Color
0283020.MXJ-B	20	LIGHT BLUE
0283030.MXJ-B	30	PINK
0283040.MXJ-B	40	GREEN
0283050.MXJ-B	50	RED
0283060.MXJ-B	60	YELLOW
0283070.MXJ-B	70	BROWN
0283080.MXJ-B	80	BLACK
0283100.MXJ-B	100	BLUE
0283120.MXJ-B	120	WHITE
0283140.MXJ-B	140	REDDISH BROWN

Dimensions

Dimensions in mm

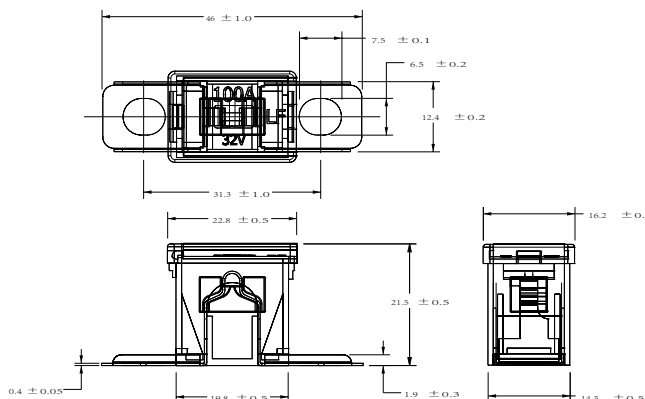

AUTO LINK PAL FUSES - 283

RoHS



Description

PAL fuses are commonly found on many Japanese and domestic built vehicles.

Specifications

Voltage Rating: 32 VDC
 Current Cycling: 24°C
 The fuses satisfy the performance requirements after 50% of the rated current is applied for 10,000 cycles. Each cycle consists of an interrupted current with the pattern of 5 minutes ON and 10 minutes OFF.
 Operating Temperature Range: -40°C to +125°C

Complies with JASO 0612

Ordering Information

Part Number	Package Size
0283xxx.H	100
0283xxx.U	500
0283xxx.MXJ	1000

Time-Current Characteristics

% of Rating	Opening Time Min / Max (s)
110	14,400 s
200	5 s / 100 s
350	0.2s / 7 s
600	0.040 s / 1 s

Ratings

Part Number	Current Rating (A)	Body Color
0283020_	20	LIGHT BLUE
0283030_	30	PINK
0283040_	40	GREEN
0283050_	50	RED
0283060_	60	YELLOW
0283070_	70	BROWN
0283080_	80	BLACK
0283100_	100	BLUE
0283120_	120	WHITE
0283140_	140	REDDISH BROWN

Dimensions

Dimensions in mm

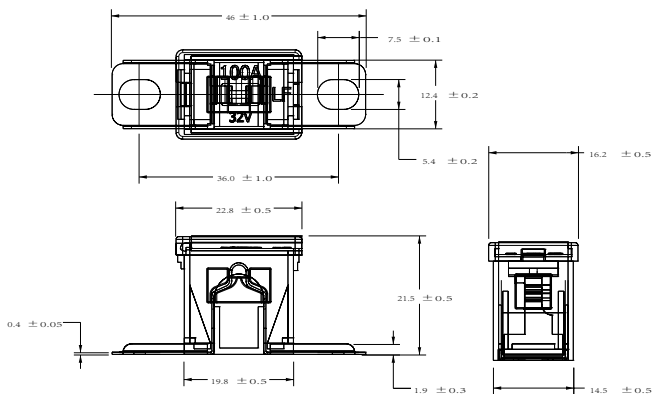

Power Distribution Centers



Flexible Electrical Center	92
FLEC™ Flexible Electrical Center	92
Hard-Wired Power Distribution Centers	94
HWB60-SEALED Hard-Wired Modules (MINI Style)	94
Bussed Power Distribution Modules	95
5 Position Block Fuse Holder for ATO® Style Blade Fuse	96
2+2 MINI® Fuse and JCASE® Holder	97
Junction Blocks	98
High Current Single Stud Feed-Thru	99
Single Stud Junction Blocks (Feed-Thru and Non-feed-Thru)	100
POWR-BLOK™ Modules	102
POWR-BLOK™ Modules: Introduction	103
Fuse Modules	104
Relay Modules	109
Specialty Modules	114
Assembly/Mounting Accessories	119
Terminals	123
Terminal Loks	130

FLEC™ FLEXIBLE ELECTRICAL CENTER

RoHS



Description

The Flexible Electrical Center (FLEC™) is a configurable power distribution module for the heavy transportation (OTB) market. It accommodates circuit protection components in a compact, sealed footprint. Your custom electrical schematic is programmed into the FLEC™ to create a simple “plug-and-play” system.

Each program is reviewed by Littelfuse for proper ratings, thermal loading, and application. The FLEC™ mates to an industry standard connection system to provide a robust solution for heavy duty environments.

Contact Littelfuse for further information on FLEC™.

Specifications

Input Terminals:	(3) M8 or 3/8" input studs rated up to 100A each (*total input current dependent on customer-provided load matrix)
Output Terminals:	(38) 1.5mm blades (for 15A fuse) (38) 2.8mm blades (for 25A fuse)
Termination:	Uses Delphi GT series terminals and connectors (sealed)
Input Stud Torque:	12-18Nm
Mounting Torque:	6-8Nm
Materials:	UL94V-0 Thermoplastic with RoHS-compliant PCB; High-temp silicone cover gasket and stud caps; Plated-Cu terminals
Operating Temperature Range:	-40°C to 85°C
Ingress Protection Rating:	IP67

Features and Benefits

Cover:	Twist-on cover design allows for single-hand installation and removal
PCB:	Multi-layer board allows for custom circuit configurations
Base:	Includes vent for pressure equalization
High Component Density:	Accepts multiple component footprints (i.e. MINI®, JCASE®, PCB-mount, etc.) in one package; PCB-mount components can be installed directly to PCB (i.e. diodes, resistors, relays) for space and cost savings
InputProtection:	MEGA® fuse can be installed across M8 input studs to protect multiple circuits in FLEC™; Additional MEGA-FLEX holder can be interlocked to FLEC™ for added fuse protection
Accessories:	Fuse puller included in cover Input stud caps provided (red and black) Spare MINI® fuse positions available in cover Cover tether included

FLEC™ FLEXIBLE ELECTRICAL CENTER

RoHS

Dimensions

Dimensions in mm

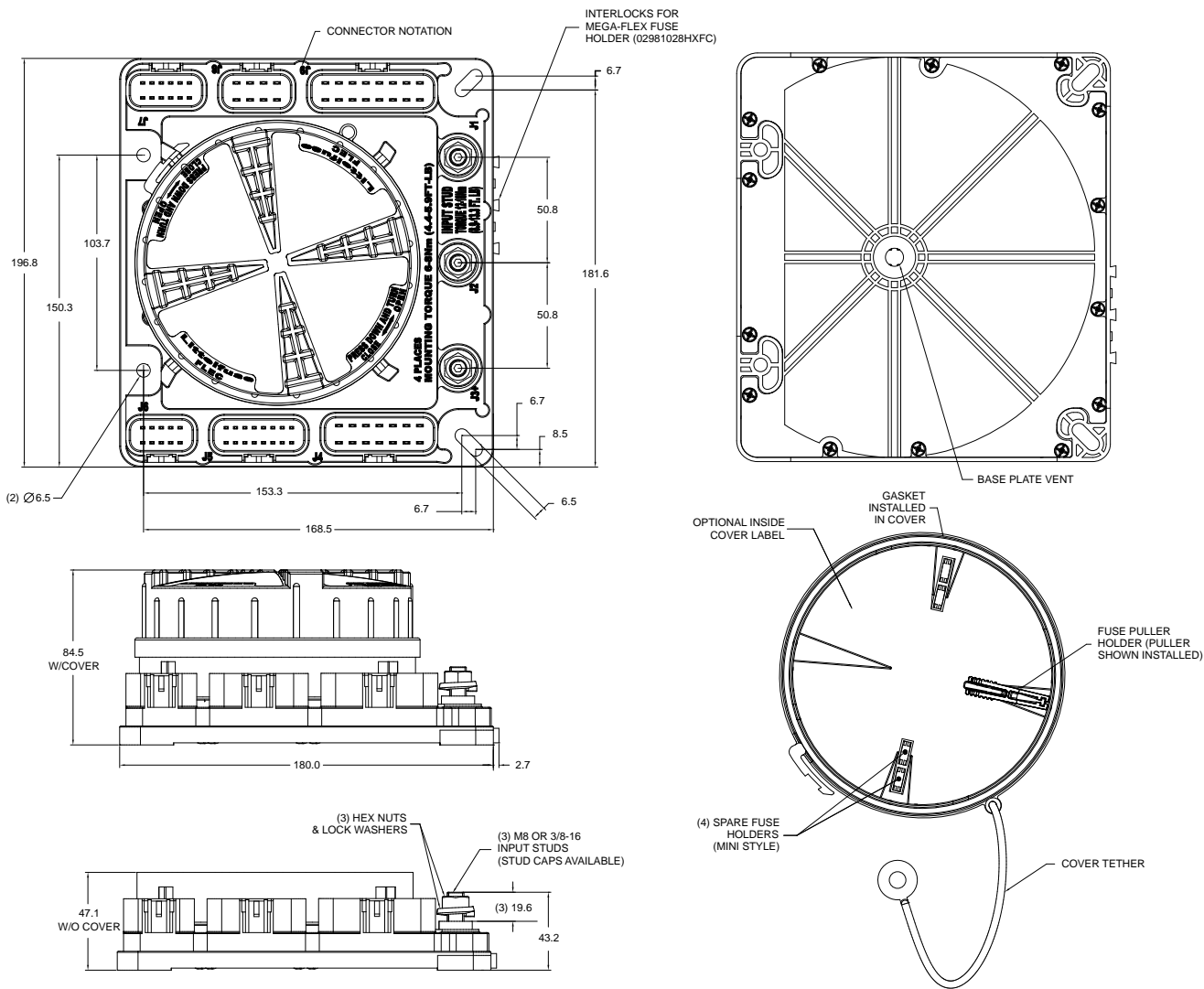

HWB60-SEALED HARD-WIRED MODULES (MINI STYLE)

RoHS



Specifications

Max Fuse Size:	30A
# of Cavities:	60
Compatible Relay Types:	280 footprint micro & mini
Mounting Torque:	6-8Nm using M6 bolts and hardware
Materials:	UL 94V-0 glass-filled thermoplastic with silicone gasket
Labels:	Module & cover options
Accessories:	Spare fuse and fuse puller holder; Cover tether; TPA
Mating Terminals and Seals:	Delphi Metri-Pack 280 Sealed Female
Wire Sizes:	0.35 - 5.0mm ²

Dimensions

Dimensions in mm (subject to change)

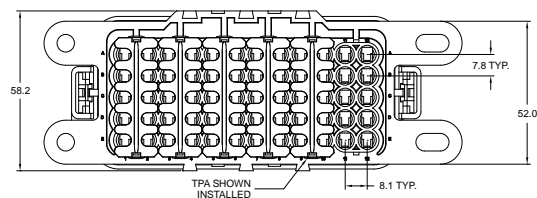
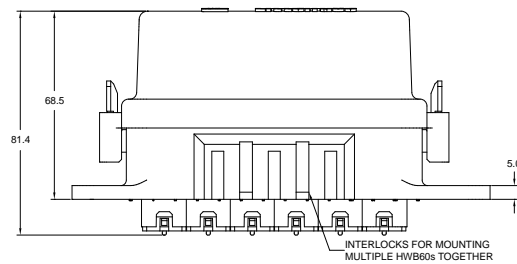
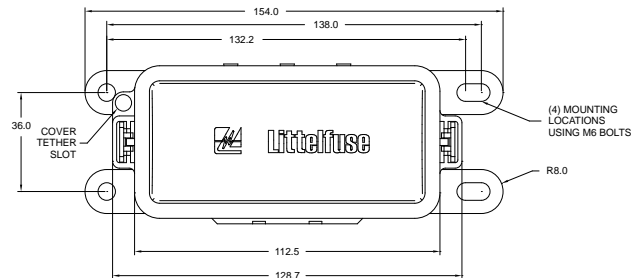

Description

The HWB60 is a hard-wired module for use with 280 style components (i.e. mini-fuses, relays, diodes, resistors, etc.) It features 60 cavities creating a high density fuse module with a compact footprint. Without internal bussing, it allows the flexibility of custom circuitry by the end user. Wires simply plug into the back of the module using sealed Delphi Metri-Pack Series 280 tanged terminals.

Sealing in the cover and around the wires allow for use in extreme environments. Dovetail features on the sides of unit allow the user to stack multiple HWB60's together to increase their circuit protection package. These same dovetails can also be used to attach an add-on component that holds a fuse puller and spare fuses. Cover tethers and TPAs (terminal position assurance locks) are also available.

Alternative component footprints may be available. Contact Littelfuse for more information.

Ratings

Part Number	Description
PDM21001LXM	Complete Assembly (Base, Cover, Gasket, and 6 TPAs shipped bulk)
868-163	Base
873-029	Cover
901-315	Gasket
883-083	TPA

Bussed Power Distribution Modules



5 Position Block Fuse Holder for ATO® Style Blade Fuse	96
2+2 MINI® Fuse & JCASE® Holder	97

5 POSITION BLOCK FUSE HOLDER

for ATO® Style Blade Fuse

RoHS



Description

Use with ATO® fuses up to 15A. Available in 5 pole unit with removable clear protective cover. Available in side or bottom positioned ¼" Q.C. terminal configurations. Unit with bottom Q.C. terminals includes detachable side mounting brackets.

Ordering Information

Part Number	Package Size
03500417TXN	10
03500417Z	120
03500418TXN	10
03500418Z	180
03500419TXN	10
03500419Z	150
03500420TXN	10
03500420Z	250

Dimensions

Dimensions in mm

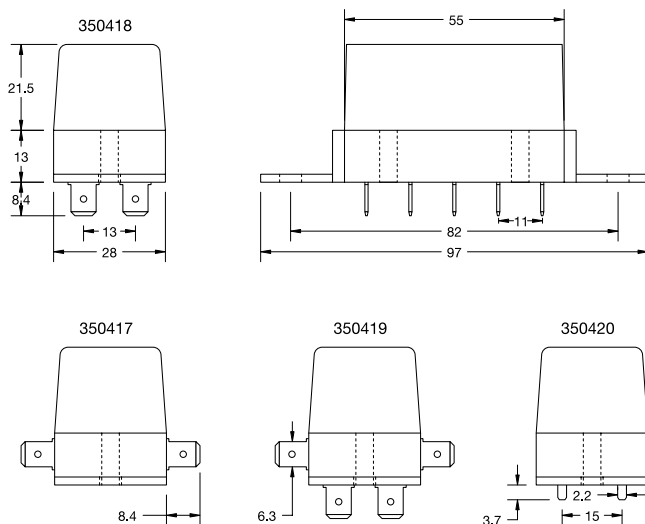

Ratings

Part Number	Description	Fuse Rating
03500418_	ATO® block 5 positions, vertical contacts	15 A
03500419_	ATO® block 5 positions, horizontal + vertical contacts	15 A
03500420_	ATO® block 5 positions, P.C. Board contacts	15 A
03500417_	ATO® block 5 positions, horizontal contacts	15 A

Corresponding fuse links see Section "Blade Fuses."

2+2 MINI® FUSE & JCASE® HOLDER

RoHS



Specifications

Mounting Torque:	6-8Nm
Input Stud Torque:	6-8Nm
Materials: Body & Cover:	UL 94V-0 Thermoplastic
Stud:	Zinc-plated steel
Bus Bar:	Tin-plated copper
Gasket:	Silicone
Mating Terminals & Seals Series:	
JCASE®:	Delphi Ducon 6.3 Sealed Male
MINI®:	Delphi Metri-Pack 280 Sealed Female

Dimensions

Dimensions in mm
(Subject to change)

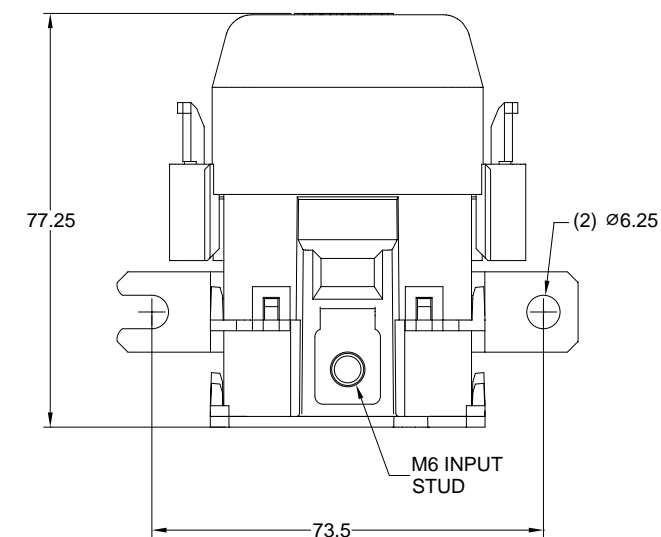
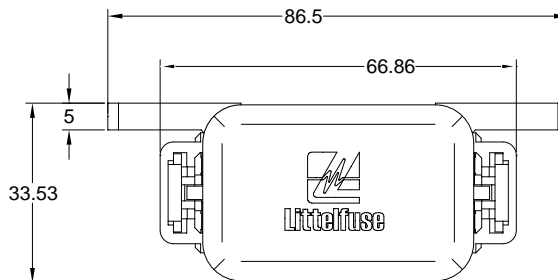

Description

The 2+2 MINI® Fuse & JCASE® Holder accommodates two MINI® fuses and two JCASE® fuses. The use of these fuse types provides an amperage range of 2-60A in a compact package. The four fuses are bussed internally to the main input power stud. This allows the user to reduce wiring by making one input connection to power four fuse circuits.

The 2+2 holder is a sealed module enabling it to be used in heavy duty environments. A stud cap is provided to protect input stud area from accidental shorts. TPAs are also included to provide secondary locking of each wire terminal.

Ratings

Part Number	Description
BPDMA104HXF1	Assembly (base, cover & gasket assembled; hardware, and TPAs shipped bulk)

Junction Blocks



High Current Single Stud Feed-Thru	99
Single Stud Junction Blocks (Feed-Thru & Non-feed-Thru)	100

HIGH CURRENT SINGLE STUD FEED-THRU

RoHS



Description

Our 3/8" pass-thru stud has a high electrical rating and low resistance due to a large cross-sectional contact area. It also uses highly conductive materials to outperform the competition.

This pass-thru stud boasts high installation torque values to allow the use of large cable sizes for high current applications. Stud caps are included to protect from accidental shorts.

The pass-thru stud is available with red or black body and stud cap to help color-code circuits in the vehicle. A plastic body locknut ensures quick and easy firewall-mount installation without the need for additional hardware.

Ratings

Part Number	Color
JBPT0001Z	Red
JBPT0002Z	Black

Specifications

Rating:	400A
Locknut Torque:	54.2 Nm
Body Mounting Nut Torque:	13.6 Nm
Materials:	Body-Nylon 66 (120°C) Contact - Copper 110 Studs - Zinc-plated steel Locknut - Zinc-plated steel Body nut - Nylon 66 Stud caps - PVC
Operating Temperature Range:	-40°C - 125°C

Dimensions

Dimensions in mm

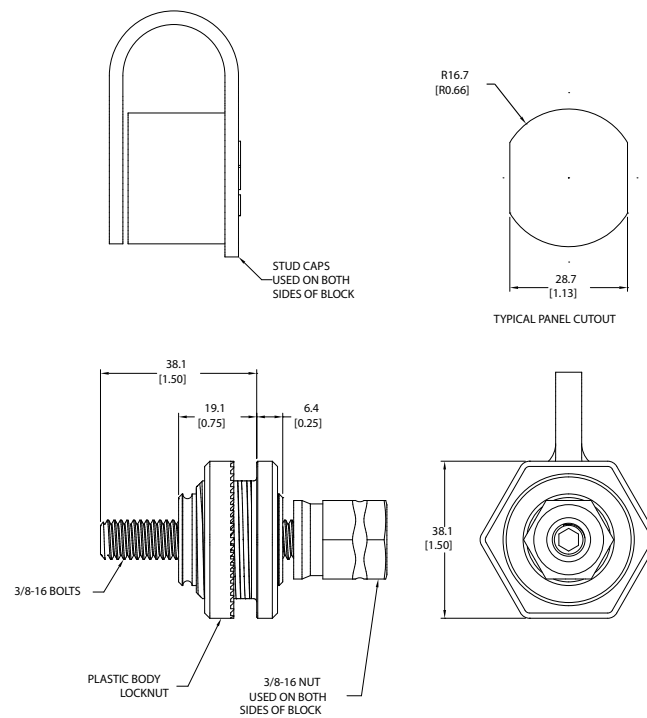

SINGLE STUD JUNCTION BLOCKS (FEED-THRU & NON-FEED-THRU)

RoHS



Specifications

Materials:

Body: UL 94V-0 Thermoplastic

Stud: Stainless steel

Hardware:

Conductive Core: Plated copper

Lockwashers and nuts available;

Protective stud caps available (red or black to match body color)

Thread Sizes:

Various available options

Operating Temperature Range:

-40°C - 125°C

Description

Junction Blocks are used as electrical connection points for the distribution of power or ground. These blocks can simplify cabling & architectures, and serve as convenient power tap points. Feed-thru versions enable firewall-mount applications and help reduce wiring costs and overall space required for cable routing.

Junction blocks are available in various thread sizes and lengths. Lock washers and nuts are included with each block. Stud caps are also available for protection from accidental shorts.

Contact Littelfuse for more sizes not shown.

SINGLE STUD JUNCTION BLOCKS (FEED-THRU & NON-FEED-THRU)

RoHS

Dimensions

Dimensions in mm

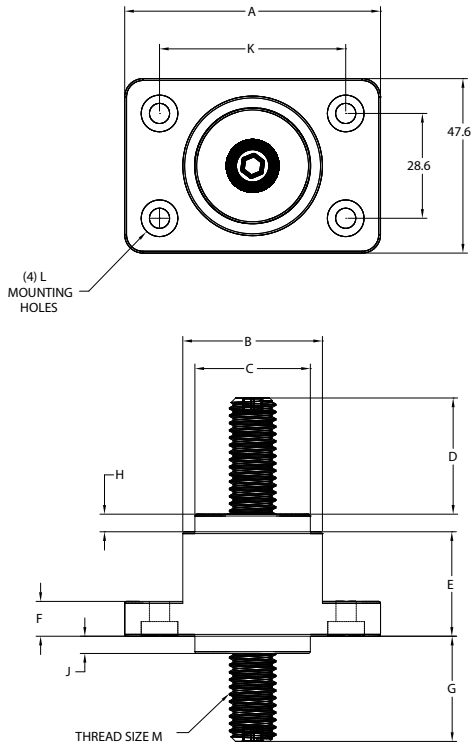

FIGURE 1

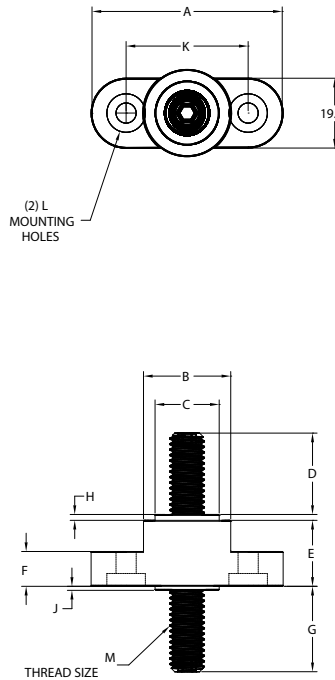

FIGURE 2

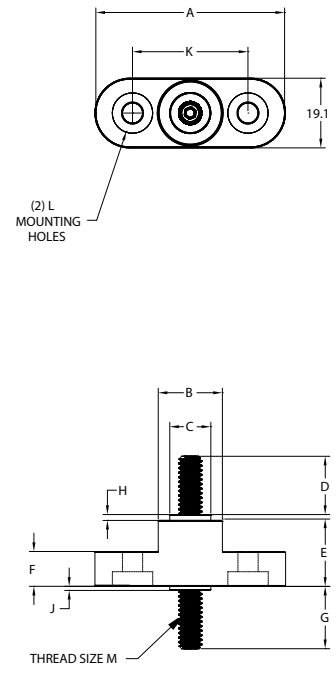

FIGURE 3

PART NUMBER	FIGURE	A	B	C	D	E	F	G	H	J	K	L	M	COLOR
JBPT2P01ZXR	1	69.8	38.1	31.7	31.7	28.6	9.5	28.6	4.8	4.8	50.8	ø5.6 hole with ø11.2 C'bore x 4.1 deep	½-13	RED
JBPT2N02ZXB	1	69.8	36.6	31.7	38.1	28.6	9.5	NONE	4.8	NONE	50.8	ø5.6	½-13	BLACK
JBPT2N03ZXB	1	69.8	36.3	31.7	38.1	28.6	9.5	NONE	4.8	NONE	50.8	ø5.6	5/16-18	BLACK
JBPT3P01ZXB	2	52.4	23.8	17.5	22.2	17.5	7.9	23.8	1.6	1.6	33.3	ø5.6 hole with ø10.4 C'bore x 3.6 deep	3/8-16	BLACK
JBPT3P02ZXB	2	52.4	22.2	15.9	15.9	28.6	7.9	23.8	1.6	1.6	33.3	ø5.6 hole with ø10.4 C'bore x 3.6 deep	3/8-16	BLACK
JBPT3N03ZXB	2	54.0	24.9	15.9	22.2	17.5	7.9	NONE	1.6	NONE	34.9	ø5.6 hole with ø9.4 C'bore x 3.6 deep	3/8-16	BLACK
JBPT3N03ZXR	2	54.0	24.9	15.9	22.2	17.5	7.9	NONE	1.6	NONE	34.9	ø5.6 hole with ø9.4 C'bore x 3.6 deep	3/8-16	RED
JBPT4P01ZXB	3	52.4	17.5	11.2	15.9	17.5	7.9	17.5	1.6	1.6	33.3	ø5.6 hole with ø10.4 C'bore x 3.6 deep	¼-20	BLACK

POWR-BLOK™ Modules



Powr-Blok™ Modules: Introduction	103
Fuse Modules	104
Relay Modules	109
Specialty Modules	114
Assembly/Mounting Accessories	119
Terminals	123
Terminal Loks	122

POWR-BLOK™ MODULES

Description

The Littelfuse POWR-BLOKS™ system gives you unlimited flexibility to design electrical distribution systems. It's a totally modular way to build your own junction box. POWR-BLOKS are perfect for applications where space or vehicle function demand a tailor made approach. The Littelfuse POWR-BLOKS can be modified, re-sized, reconfigured or added to at any time.

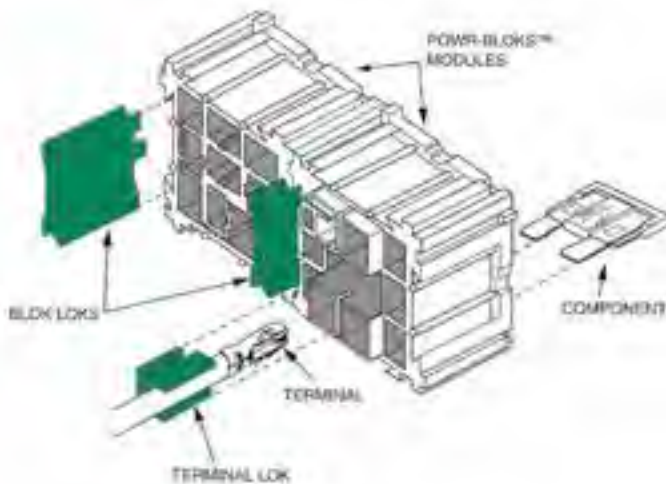

Mechanical Strength for Any Application

POWR-BLOKS modules are molded from glass reinforced nylon for dimensional stability, excellent rigidity, high and low temperature resistance and tensile strength:

Specifications

Test	POWR-BLOKS™ Standard
Voltage Rating	48VDC
Temperature range	-40°C to +125°C
Durability	Minimum 50 cycles of engagement/disengagement
Drop	1.22 meters onto wooden platform
Thermal Shock	5 Cycles from -40°C to +125°C
Mechanical Shock	50g in each of 3 mutually perpendicular axis
Fluid Compatibility	Gasoline, diesel fuel, motor oil, antifreeze, brake fluid, ATF

*Max. Current Indication

The information listed as Max. current indication is to be used as a guideline only. The maximum allowable rating of the fuses used depends on design criteria such as maximum current, nominal current the duration for which the circuits are energized, as well as external factors as ambient temperature. All modules should therefore be tested as an assembly, and users should make their own evaluation to determine the suitability of the product for their specific applications.

How to use the Littelfuse POWR-BLOKS system

1. Identify the electrical system parameters
 - Space availability and requirements
 - Circuit protection components
 - Relay and flasher components
 - Components for special needs
2. Select the Littelfuse POWR-BLOKS components. Lay out the electrical panel as designed. Then determine the appropriate type and quantity of POWR-BLOKS modules, BLOK LOKS and TERMINAL LOKS you need.
3. Build the panel by row. POWR-BLOKS can be assembled without special tools. Assemble the block from the rear by placing all modules face down on a flat surface. POWR-BLOKS should be designed by row, either going across or up and down.
4. Use BLOK LOKS to interconnect modules. BLOK LOKS are used to connect and stack POWR-BLOKS modules. Press together a row of modules and insert green BLOK LOKS until they snap into place. Repeat this procedure to interlock all assembled rows.
5. Add mounting modules. Once a POWR-BLOKS panel is assembled, add mounting modules that are most suitable for your application. Mounting options include surface mounting legs, a side mounting bracket and a mounting module with three different sized spacers.
6. Plug in terminated wiring. Wire your POWR-BLOKS panel and plug in the terminated wires, then insert the optional matching TERMINAL LOKS devices. Littelfuse TERMINAL LOKS are designed to fit special POWR-BLOKS modules and inserted in the same manner as BLOK LOKS.

The information and illustrations given in this catalogue are believed to be reliable and accurate. Littelfuse makes no warranties as to their accuracy or completeness, and disclaims any liability in connection with their use. Littelfuse's only obligations are those in the standard terms of sale for this product and Littelfuse will not be liable for any consequential or other damages arising out of the use or misuse of this product. Littelfuse reserves the right to make changes to the contents hereof without notice. It is suggested that at the time of inquiry Littelfuse Sales personnel be contacted directly for verification of published specifications and product availability.

Fuse Modules



2-Position ATO[®] Style Fuse and Circuit Breaker Module	105
4-Position ATO[®] Style Fuse and Circuit Breaker Module	105
7-Position ATO[®] Style Fuse and Circuit Breaker Module	106
4-Position MINI[®] Style Fuse Module	106
6-Position MINI[®] Style Fuse Module	107
8-Position MINI[®] Style Fuse Module	107
2-Position MAXI[™] Style Fuse Module	108
4-Position MAXI[™] Style Fuse Module	108

2-POSITION ATO® STYLE FUSE AND CIRCUIT BREAKER MODULE

RoHS



Dimensions

Dimensions in mm

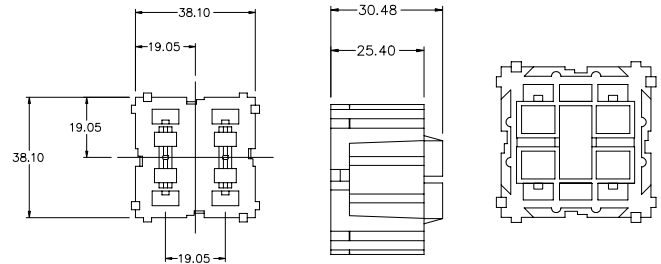

Ratings

Part Number	Max. Current Indication	Terminals (see according section)	Terminal Loks (see according section)
03540501Z (40 pcs.)	60A	Type 1 or 7	Type 4, 5 or 6

4-POSITION ATO® STYLE FUSE AND CIRCUIT BREAKER MODULE

RoHS

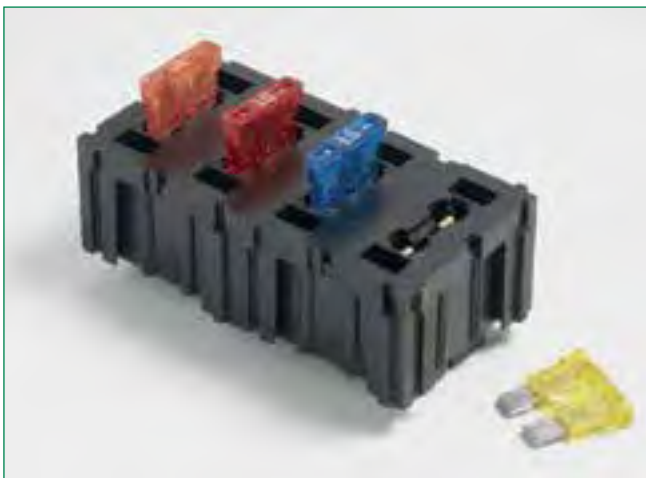

Dimensions

Dimensions in mm

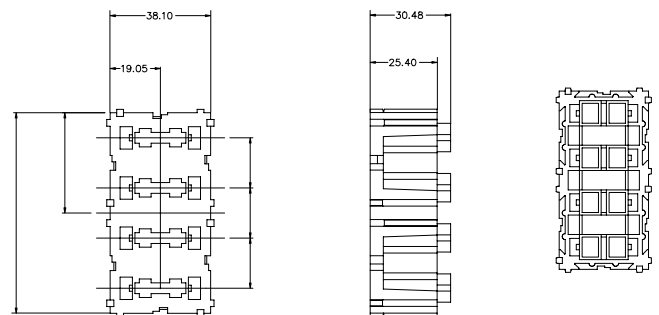

Ratings

Part Number	Max. Current Indication	Terminals (see according section)	Terminal Loks (see according section)
03540502Z (20 pcs.)	120A	Type 1 or 7	Type 4, 5, 6 or 7

7-POSITION ATO® STYLE FUSE AND CIRCUIT BREAKER MODULE

RoHS



Dimensions

Dimensions in mm

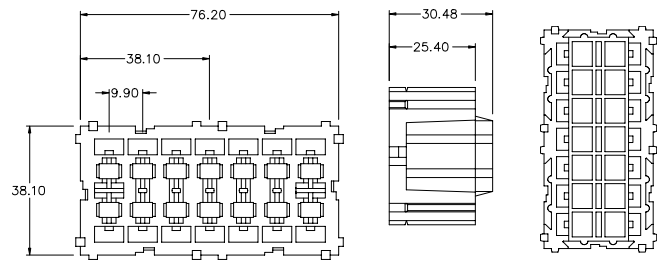

Ratings

Part Number	Max. Current Indication	Terminals (see according section)	Terminal Loks (see according section)
03540503Z (20 pcs.)	120A	Type 1 or 7	Type 4 or 5

4-POSITION MINI® STYLE FUSE MODULE

RoHS



Dimensions

Dimensions in mm

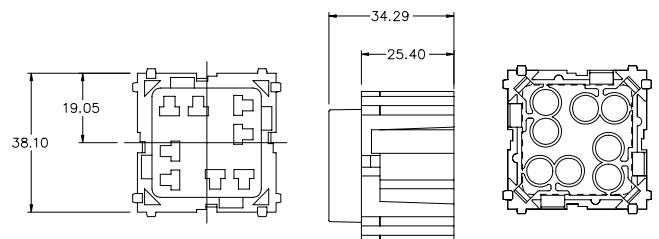

Ratings

Part Number	Max. Current Indication	Terminals (see according section)	Terminal Loks (see according section)
03540532Z (40 pcs.)	60A	Type 6	-

6-POSITION MINI® STYLE FUSE MODULE

RoHS



Dimensions

Dimensions in mm

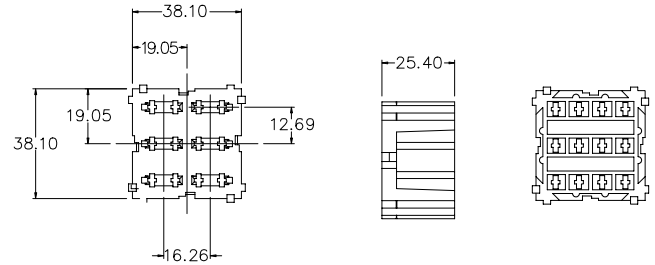

Ratings

Part Number	Max. Current Indication	Terminals (see according section)	Terminal Loks (see according section)
03540543Z (40 pcs.)	60A	Type 8	-

8-POSITION MINI® STYLE FUSE MODULE

RoHS



Dimensions

Dimensions in mm

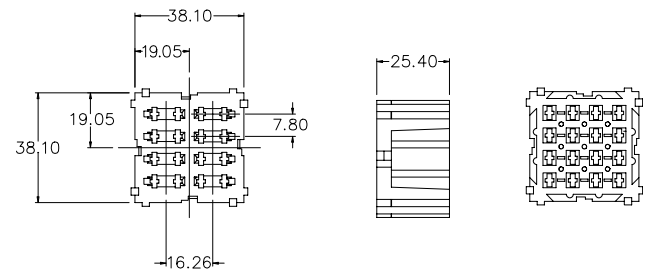

Ratings

Part Number	Max. Current Indication	Terminals (see according section)	Terminal Loks (see according section)
03540544Z (40 pcs.)	60A	Type 8	-

2-POSITION MAXI™ STYLE FUSE MODULE

RoHS



Dimensions

Dimensions in mm

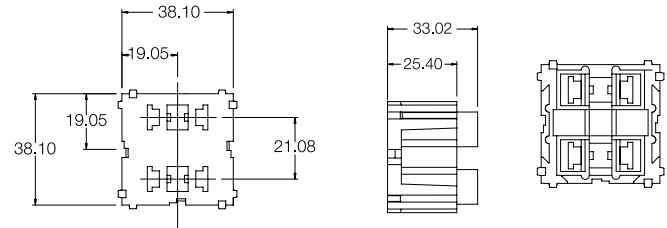

Ratings

Part Number	Max. Current Indication	Terminals (see according section)	Terminal Loks (see according section)
03540549Z (40 pcs.)	80A	Type 2	Type 8

4-POSITION MAXI™ STYLE FUSE MODULE

RoHS



Dimensions

Dimensions in mm

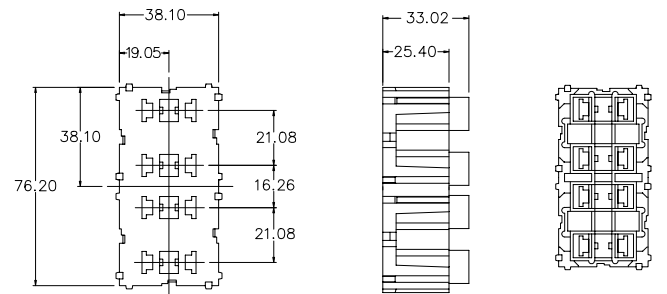

Ratings

Part Number	Max. Current Indication	Terminals (see according section)	Terminal Loks (see according section)
03540505Z (20 pcs.)	160A	Type 2	Type 8

Relay Modules



1-Position ISO Relay Module	110
2-Position ISO Relay Module	110
3-Position Micro Relay Module	111
1-Position 9 Pin Relay Module	111
2-Position 280 Micro Relay + 2 Position MINI® Style Fuse	112
1-Position Power Relay Module	112
2-Pin Flasher Module	113

1-POSITION ISO RELAY MODULE

Alternative for: 3 pin flasher module

RoHS



Dimensions

Dimensions in mm

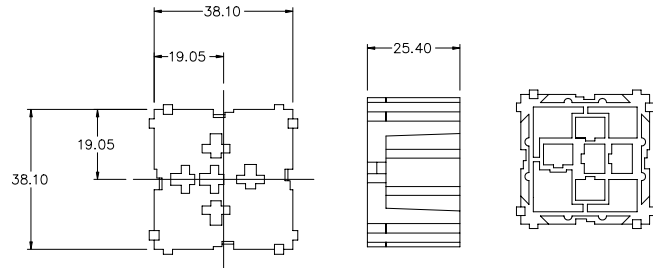

Ratings

Part Number	Remarks	Terminals (see according section)	Terminal Loks (see according section)
03540506Z (40 pcs.)	-	Type 3	Type 1

2-POSITION ISO RELAY MODULE

Alternative for: 3 pin flasher module

RoHS



Dimensions

Dimensions in mm

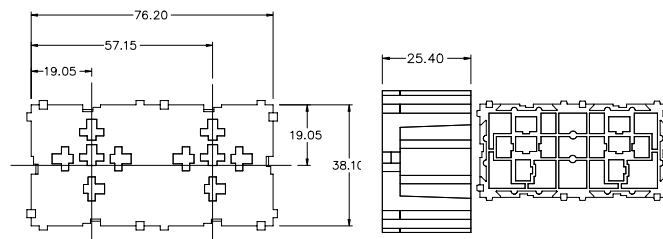

Ratings

Part Number	Remarks	Terminals (see according section)	Terminal Loks (see according section)
03540536Z (20 pcs.)	-	Type 3	Type 1

3-POSITION MICRO RELAY MODULE

RoHS



Dimensions

Dimensions in mm

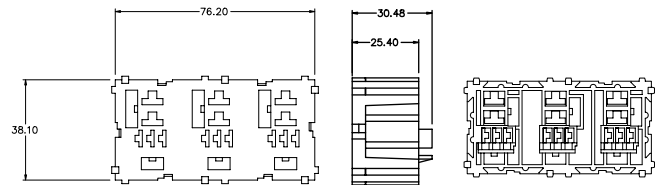

Ratings

Part Number	Max. Current Indication	Terminals (see according section)	Terminal Loks (see according section)
03540507Z (20 pcs.)	Coil and normally closed contacts	Type 5	Type 3
03540507Z (20 pcs.)	Normally open contacts	Type 3	Type 2

1-POSITION 9 PIN RELAY MODULE

RoHS



Dimensions

Dimensions in mm

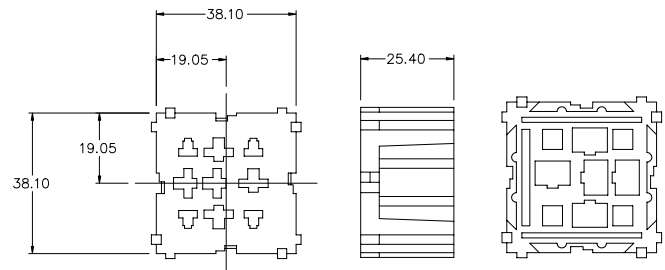

Ratings

Part Number	Max. Current Indication	Terminals (see according section)	Terminal Loks (see according section)
03540542Z (40 pcs.)	5 "Inner" pins	Type 3	Type 1
03540542Z (40 pcs.)	4 "Outer" pins	Type 6	-

2-POSITION 280 MICRO RELAY + 2 POSITION MINI® STYLE FUSE

RoHS



Dimensions

Dimensions in mm

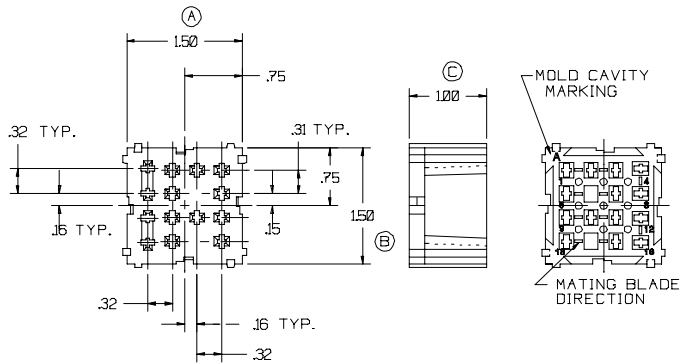

Ratings

Part Number	Max. Current Indication	Terminals (see according section)	Terminal Loks (see according section)
03540551Z (40 pcs.)	Max. current indication 30A	Type 8	-

1-POSITION POWER RELAY MODULE

RoHS



Dimensions

Dimensions in mm

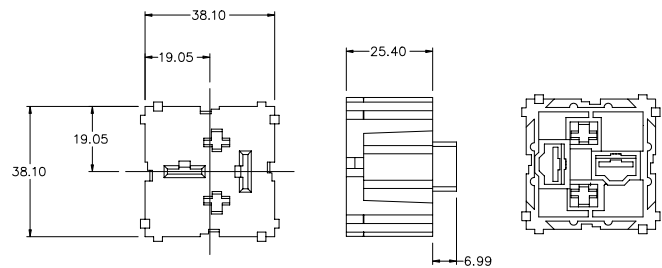

Ratings

Part Number	Max. Current Indication	Terminals (see according section)	Terminal Loks (see according section)
03540535Z (40 pcs.)	Coil	Type 3	Type 1
03540535Z (40 pcs.)	Contacts	Type 4	-

2-PIN FLASHER MODULE

RoHS

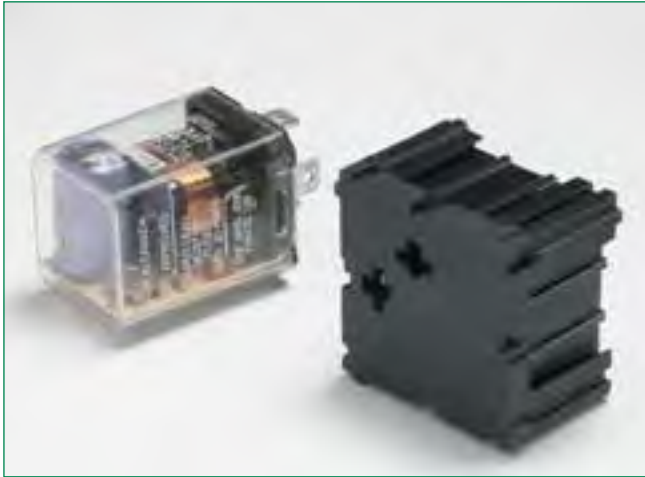

Dimensions

Dimensions in mm

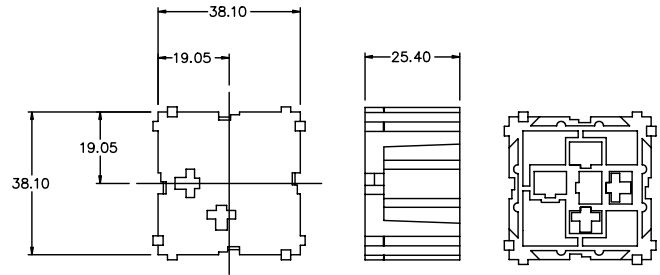

Ratings

Part Number	Max. Current Indication	Terminals (see according section)	Terminal Loks (see according section)
03540508Z (40 pcs.)	-	Type 3	Type 1

Specialty Modules



Blank Module	115
2-Position Blank Module	115
Power Tap Module	116
2-Stud Assembly Module	116
4-Stud Assembly Module	117
2-Position Push Button Circuit Breaker Module	117
Storage Module/Drawer Insert	118
Splash Proof Cover for: 4-Position MINI[®] Fuse Module	118

BLANK MODULE

RoHS



Dimensions

Dimensions in mm

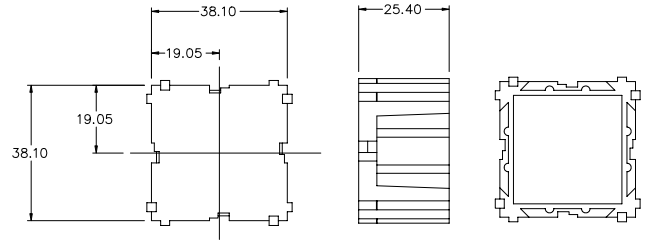

Ratings

Part Number	Remarks
03540520Z (40 pcs.)	-

2-POSITION BLANK MODULE

RoHS



Dimensions

Dimensions in mm

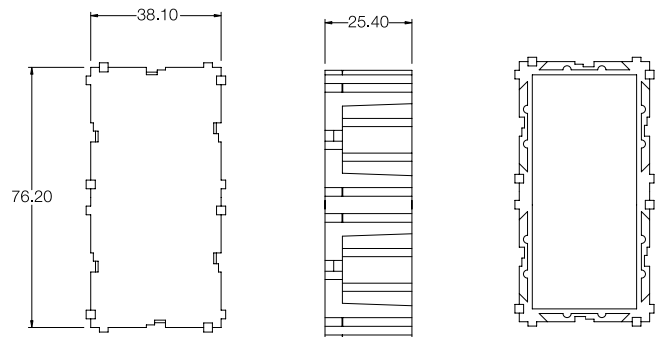

Ratings

Part Number	Remarks
03540550Z (20 pcs.)	-

POWER TAP MODULE

RoHS

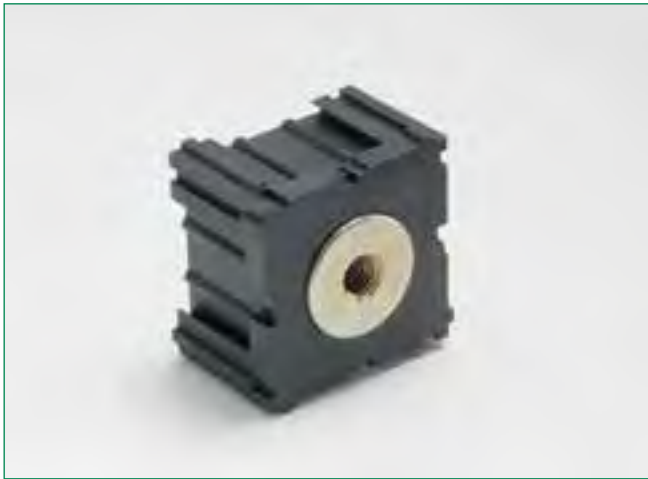

Dimensions

Dimensions in mm

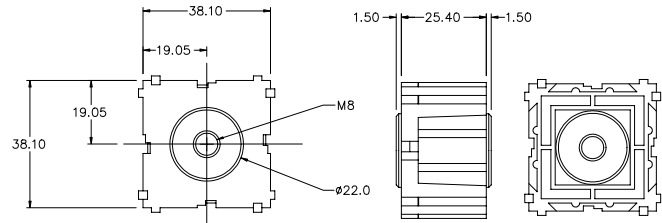

Ratings

Part Number	Remarks
03540539Z (40 pcs.)	M8 Tread Metric
03540512Z (100 pcs.)	1/4 inch - 20 thread
03540513Z (100 pcs.)	5/16 inch - 18 thread

2-STUD ASSEMBLY MODULE

RoHS



Dimensions

Dimensions in mm

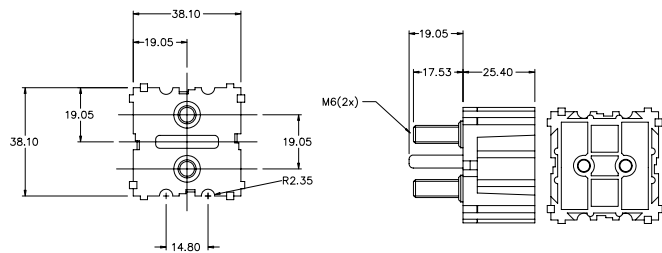

Ratings

Part Number	Remarks
03540537Z (20 pcs.)	M6 Thread, Metric

4-STUD ASSEMBLY MODULE

RoHS



Dimensions

Dimensions in mm

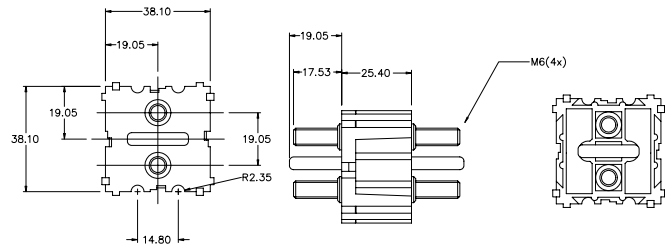

Ratings

Part Number	Remarks
03540538Z (20 pcs.)	M6 Thread Metric

2-POSITION PUSH BUTTON CIRCUIT BREAKER MODULE

RoHS



Dimensions

Dimensions in mm

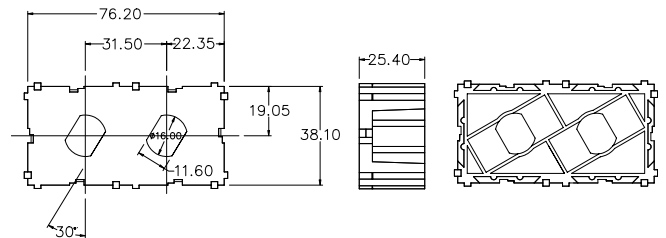

Ratings

Part Number	Remarks
03540504Z (20 pcs.)	-

STORAGE MODULE/DRAWER INSERT

RoHS



Dimensions

Dimensions in mm

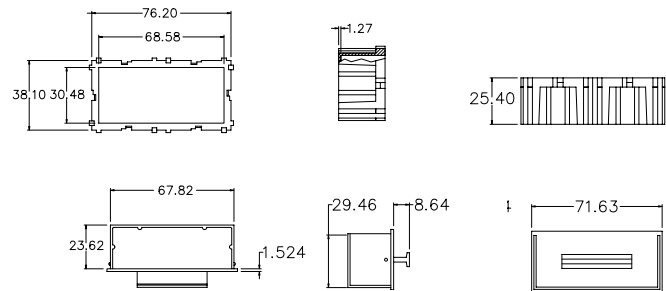

Ratings

Part Number	Remarks
03540521Z (20 pcs.)	Body
03540522Z (20 pcs.)	Drawer

SPLASH PROOF COVER FOR: 4-POSITION MINI® FUSE MODULE

RoHS



Dimensions

Dimensions in mm

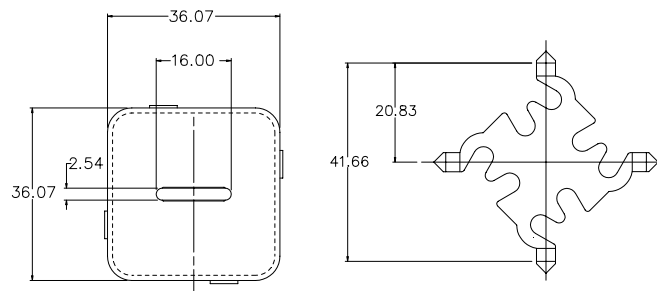

Ratings

Part Number	Remarks
03540534Z (20 pcs.)	Cover
03540533Z (20 pcs.)	Lock
09130085Z (20 pcs.)	Seal

Assembly/Mounting Accessories



Assembly Accessories—BLOK-LOKS™	120
Mounting Accessories—Mounting Standoffs	120
Mounting Accessories—Mounting Module	121
Mounting Leg	121
Mounting Accessories—Flush Mounting Leg	122
Side Mounting Bracket	122

ASSEMBLY ACCESSORIES—BLOK LOKS™

RoHS



Dimensions

Dimensions in mm

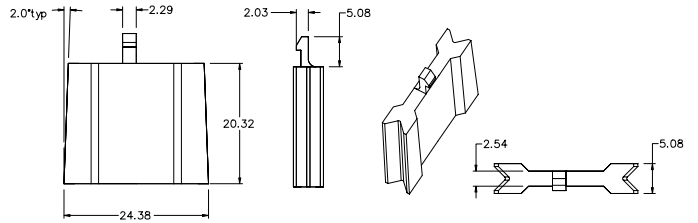

Ratings

Part Number	Remarks
03540523Z (250 pcs.)	-

MOUNTING ACCESSORIES—MOUNTING STANDOFFS

RoHS



Dimensions

Dimensions in mm

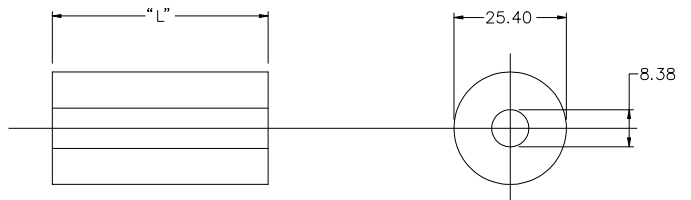

Ratings

Part Number	Remarks
03540515Z (10 pcs.)	0.75 Inch / 19mm
03540516Z (10 pcs.)	1 Inch / 25.4mm
03540517Z (10 pcs.)	1.25 Inch / 31.7mm

MOUNTING ACCESSORIES—MOUNTING MODULE

RoHS

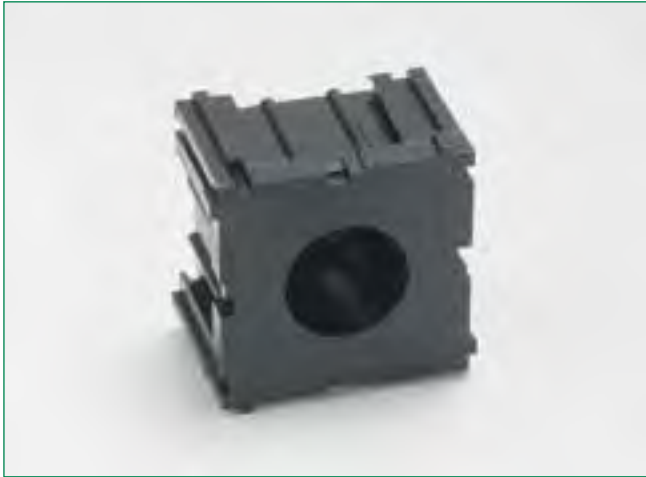

Dimensions

Dimensions in mm

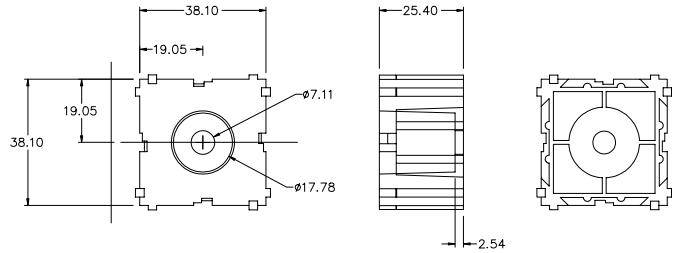

Ratings

Part Number	Remarks
03540514Z (40 pcs.)	-

MOUNTING LEG

RoHS



Dimensions

Dimensions in mm

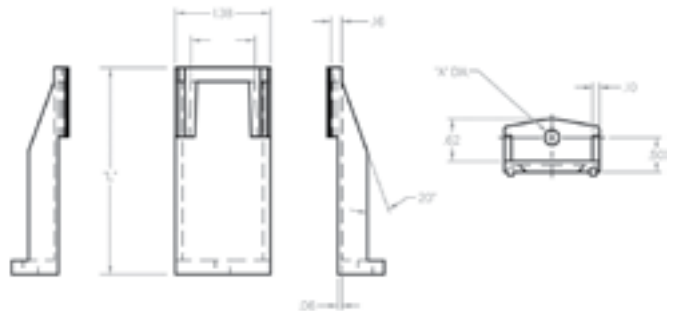

Ratings

Part Number	Remarks
03540541Z (50 pcs.)	2.50 Inch / 63.5mm
03540518Z (50 pcs.)	3 Inch / 76.2mm

MOUNTING ACCESSORIES—FLUSH MOUNTING LEG

RoHS



Dimensions

Dimensions in mm

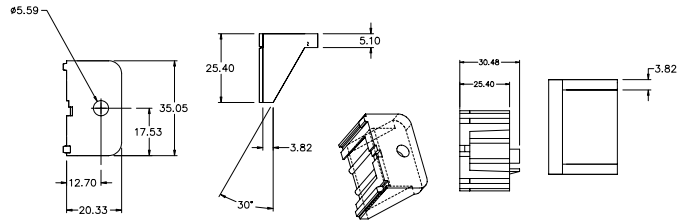

Ratings

Part Number	Remarks
03540519Z (50 pcs.)	-

SIDE MOUNTING BRACKET

RoHS



Dimensions

Dimensions in mm

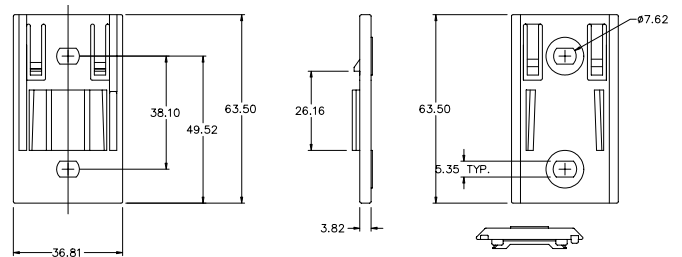

Ratings

Part Number	Remarks
03540540Z (50 pcs.)	-

Terminals



Terminal Type 1	124
Terminal Type 2	125
Terminal Type 3	125
Terminal Type 4	126
Terminal Type 5	126
Terminal Type 6	127
Terminal Type 7	127
Terminal Type 8	128
Starter Terminals	129

TERMINAL TYPE 1

RoHS



Terminal Loks

Description	Wire Diam.	Type of terminal loks
For part number: 354501 / 354502 / 354503	0.50 - 2 mm ²	4
For part number: 354501 / 354502 / 354503	0.50 - 2 & 3.3 - 5.3 mm ²	5
For part number: 354501 / 354502	0.50 - 2 mm ²	6
For part number: 354502	0.50 - 2 mm ²	7

Ratings

Part Number	Description	Wire Diam.	Material
913-070 (Reeled per 2200 pcs) 0913070001 (Single per 250 pcs)	Heavy Duty + spring clip*	0.5-0.8 mm ² / 18-20AWG 0.5-0.8 mm ² / 18-20AWG	Brass
913-071 (Reeled per 2200 pcs) 913-071XS (Reeled per 2200 pcs)	Heavy Duty + spring clip*	1.33-2.09 mm ² / 14-16AWG 1.33-2.09 mm ² / 14-16AWG	Brass Silver plated copper
0913071001 (Single per 250 pcs) 913-072 (Reeled per 2200 pcs)	Heavy Duty + spring clip*	1.33-2.09 mm ² / 14-16AWG 3.32-5.37 mm ² / 10-12AWG	Brass
913-072XS (Reeled per 2200 pcs) 0913072001 (Single per 250 pc)	Heavy Duty + spring clip*	3.32-5.37 mm ² / 10-12AWG 3.32-5.37 mm ² / 10-12AWG	Silver plated copper Brass
913-058 (Reeled per 4500 pcs) 0913058001 (Single per 250 pcs)	Standard Duty	0.5-0.8 mm ² / 18-20AWG 0.5-0.8 mm ² / 18-20AWG	Brass
913-059 (Reeled per 4500 pcs) 0913059001 (Single per 250 pcs)	Standard Duty	1.33-2.09 mm ² / 14-16AWG 1.33-2.09 mm ² / 14-16 AWG	Brass
913-060 (Reeled per 4500 pcs) 0913060001 (Single per 250 pcs)	Standard Duty	3.32-5.37 mm ² / 10-12AWG 3.32-5.37 mm ² / 10-12AWG	Brass

* Spring clip material: Stainless steel

TERMINAL TYPE 2

RoHS



Terminal Loks

Description	Wire Diam.	Type of terminal loks
For part number: 354505	0,50 - 2 mm ²	8

Ratings

Part Number	Description	Wire Diam.	Material
913-063 (Reeled per 1200 pcs) 0913063001 (Single per 250 pcs)	Female 8.0 mm	0.82-1.33 mm ² / 18-16AWG 0.82-1.33 mm ² / 18-16AWG	Silver plated brass
913-064 (Reeled per 1200 pcs) 0913064001 (Single per 250 pcs)	Female 8.0 mm	2.09-3.32 mm ² / 14-12AWG 2.09-3.32 mm ² / 14-12AWG	Silver plated brass
913-068 (Reeled 1200 pcs) 0913068001 (Single per 250 pcs)	Female 8.0 mm	5.37mm ² / 10AWG 5.37mm ² / 10AWG	Silver plated brass

TERMINAL TYPE 3

RoHS



Terminal Loks

Description	Wire Diam.	Type of terminal loks
For part number: 354506 / 354508 / 354535 / 354536	–	1
For part number: 354505	–	2

Ratings

Part Number	Description	Wire Diam.	Material
913-053 (Reeled per 2000 pcs) 0913053001 (Single per 250 pcs)	–	0.5-0.8 mm ² / 18-20AWG 0.5-0.8 mm ² / 18-20AWG	Tin plated brass
913-253 (Reeled per 3000 pcs)	–	0.5-1.00 mm ² (metric)	Tin plated brass
913-065 (Reeled per 2100 pcs) 0913065001 (Single per 250 pcs)	–	1.33-2.09 mm ² / 14-16AWG 1.33-2.09 mm ² / 14-16AWG	Tin plated brass
913-265 (Reeled per 2500 pcs)	–	1.1-2.50 mm ² (metric)	Tin plated brass
913-055 (Reeled per 1900 pcs) 0913055001 (Single per 250 pcs)	–	3.32-5.37 mm ² / 10-12AWG 3.32-5.37 mm ² / 10-12AWG	Tin plated brass
913-255 (Reeled per 15000 pcs)	–	4.0-6.0 mm ² (metric)	Tin plated brass

TERMINAL TYPE 4

RoHS



Ratings

Part Number	Description	Wire Diam.	Material
913-073 (Reeled per 2000 pcs) 0913073001 (Single per 250 pcs)	Female	3.0-6.0 mm ² /10-12AWG 3.0-6.0 mm ² /10-12AWG	Tin plated Brass
913-074 (Reeled per 1000 pcs) 0913074001 (Single per 250 pcs)	Female	6.0-10.0 mm ² /8-10AWG 6.0-10.0 mm ² /8-10AWG	Tin plated Brass

TERMINAL TYPE 5

RoHS



Ratings

Part Number	Description	Wire Diam.	Material
913-067 (Reeled per 3500 pcs) 0913067001 (Single per 250 pcs)	Female	0.82-1.33 mm ² /16-18AWG 0.82-1.33 mm ² /16-18AWG	Tin plated silicon bronze
913-066 (Reeled per 3000 pcs) 0913066001 (Single per 250 pcs)	Female	2.09-3.32 mm ² /12-14AWG 2.09-3.32 mm ² /12-14AWG	Tin plated silicon bronze

TERMINAL TYPE 6

RoHS



Ratings

Part Number	Description	Wire Diam.	Material
913-772 (Reeled per 2500 pcs) 0913772001 (Single per 250 pcs)	Female	0.5-0.8 mm ² /18-20AWG 0.5-0.8 mm ² /18-20AWG	Tin plated brass
913-773 (Reeled per 2500 pcs) 0913773001 (Single per 250 pcs)	Female	1.33-2.09 mm ² /14-16AWG 1.33-2.09 mm ² /14-16AWG	Tin plated brass
913-774 (Reeled 2000 pcs) 0913774001 (Single per 250 pcs)	Female	3.32-5.37 mm ² /10-12AWG 3.32-5.37 mm ² /10-12AWG	Tin plated brass

TERMINAL TYPE 7

RoHS



Ratings

Part Number	Description	Wire Diam.	Material
09130075Z (Per 20 pcs)	Bus bar 2 position	5.0-8.0 mm ² /8-10AWG	Copper
09130076Z (Per 20 pcs)	Bus bar 4 position	5.0-8.0 mm ² /8-10AWG	Copper
09130077Z (Per 20 pcs)	Bus bar 7 position	5.0-8.0 mm ² /8-10AWG	Copper

TERMINAL TYPE 8

RoHS



Ratings

Part Number	Description	Wire Diam.	Material
913-769 (Reeled per 4200 pcs) 0913769001 (Single per 250 pcs)	Female	0.5-1.0 mm ² 0.5-1.0 mm ²	Part.Gold plated Brass
913-770 (Reeled per 1000 pcs) 0913770001 (Single per 250 pcs)	Female	1.5-2.5 mm ² 1.5-2.5 mm ²	Tin plated bronze

STARTER TERMINALS

RoHS



Description

The starter terminal series are cable lugs for heavy-duty applications such as starter motors and battery connections.

Ratings

Part Number	mm ²	Mounting Hole	Width (mm)	Material	Plating	Ref.
09130633LXN (50 pcs) 09130633Z (1250 pcs)	2.5-6.0	6.5 mm	11	Cu	Sn	2906
09130634LXN (50 pcs) 09130634Z (600 pcs)	6.0-15	8.4 mm	15	Cu	Sn	2910
09130635LXN (50 pcs) 09130635Z (400 pcs)	10 -25	8.4 mm	15	Cu	Sn	2916
09130636LXN (50 pcs) 09130636Z (200 pcs)	16-35	10.5 mm	19	Cu	Sn	29025
09130637LXN (50 pcs) 09130637Z (150 pcs)	25-50	10.5 mm	19	Cu	Sn	29035
09130638LXN (50 pcs) 09130638Z (100 pcs)	35-70	10.5 mm	19	Cu	Sn	29050
09130639LXN (50 pcs) 09130639Z (50 pcs)	50-95	13.5 mm	22	Cu	Sn	29070
09130640LXN (50 pcs) 09130640Z (600 pcs)	16	6.4 mm	11	Cu	Sn	2916 HK
09130641LXN (50 pcs) 09130641Z (300 pcs)	25	8.4 mm	15	Cu	Sn	29025 HK
09130642LXN (50 pcs) 09130642Z (200 pcs)	35	8.4 mm	15	Cu	Sn	29035 HK (8.4)
09130643LXN (50 pcs) 09130643Z (150 pcs)	35	10.5 mm	19	Cu	Sn	29035 HK (10.5)
09130644LXN (50 pcs) 09130644Z (100 pcs)	50	8.4 mm	17	Cu	Sn	29050 HK (8.4)
09130645LXN (50 pcs) 09130645Z (125 pcs)	50	10.5 mm	19	Cu	Sn	29050 HK (10.5)
09130646LXN (50 pcs) 09130646Z (75 pcs)	70	10.5 mm	21	Cu	Sn	29070 HK

Terminal Loks



Terminal Lok Type 1 through 8

131

TERMINAL LOKS

RoHS

Terminal Lok Type 1



Terminal Lok Type 5



Terminal Lok Type 2



Terminal Lok Type 6



Terminal Lok Type 3



Terminal Lok Type 7

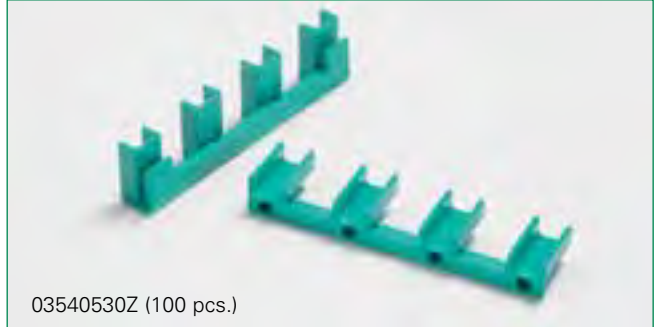

Terminal Lok Type 4



Terminal Lok Type 8



Fuse Holders



Inline Fuse Holders	133
PCB Fuse Holders	142
Stackable/Panel Mount Fuse Holders	150
Bolt-Down Fuse Holders and Assemblies	159

Inline Fuse Holders



Inline Splashproof Fuse Holder for MINI® Style Blade Fuse	134
Inline Fuse Holder for ATO® Style Blade Fuse	135
Inline Splashproof Fuse Holder for ATO® Style Blade Fuse	135
Add-A-Circuit MINI® Style	136
Add-A-Circuit ATO® Style	136
Fuse Holder for MAXI® Style Blade Fuse	137
MAXI® Components	137
Splash Resistant Fuse Holder for MAXI® Style Blade Fuse	138
Splash Resistant MAXI® Components	138
Inline Fuse Holder for MAXI® Style Blade Fuse	139
Inline Fuse Holder for JCASE® Style Fuses	140

INLINE SPLASHPROOF FUSE HOLDER

for MINI® Style Blade Fuse

RoHS



Specifications

Housing: Out of thermoplastic (UL 94-V0, heat-resistant)
Color: Black

Ordering Information

Part Number	Package Size
0FHM000xLXN	50
0FHM000xZXJ	1000

Description

Used with MINI / FK1 Fuse. Includes protective cover for harsh environment. This product is compatible with a MINI diode.

Dimensions

Dimensions in mm

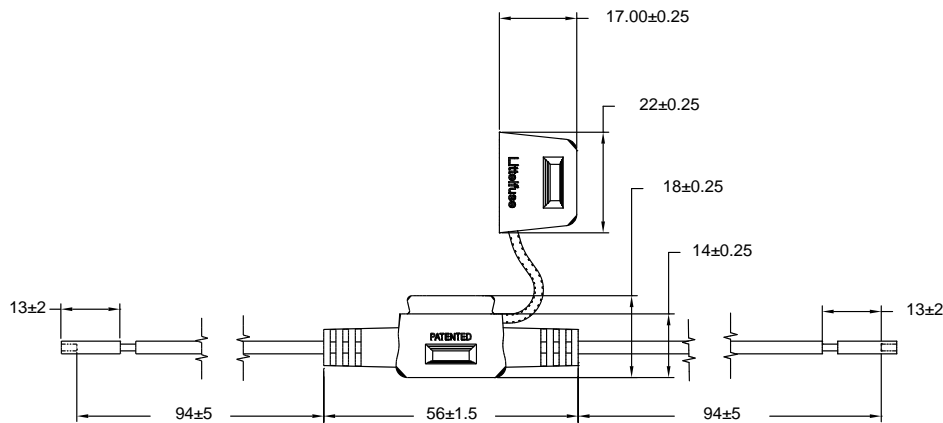

Ratings

Part Number	Description	Fuse Rating
0FHM0001_	14AWG/2.1mm ² stranded black wire	20 A
0FHM0002_	12AWG/3.3mm ² stranded orange wire	30 A

Wire length, color and diameter can be customized upon request.

Customization requires minimum order quantities depending on nature of modifications.

INLINE FUSE HOLDER FOR ATO® STYLE BLADE FUSE

RoHS



Description

Used with ATO®/ FKS Fuse. Supplied with two 4" / 102mm wire leads.

Ordering Information

Part Number	Package Size
0FHA0001ZXJ	1000
0FHA0002ZXJ	1000

Dimensions

Dimensions in mm

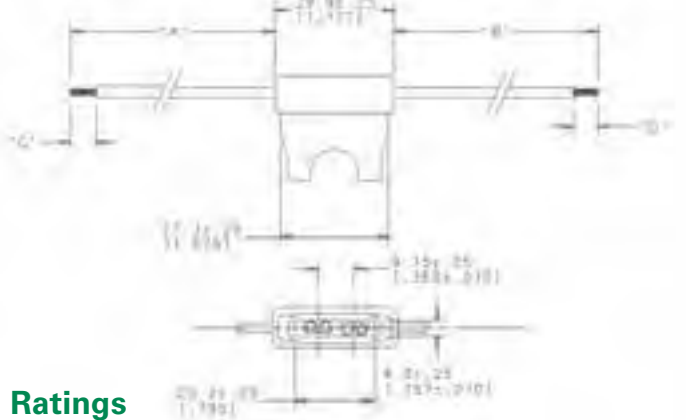

Ratings

Part Number	Description	Fuse Rating
0FHA0001_	16AWG/1.3mm ² stranded black wire	20 A
0FHA0002_	12AWG/3.3mm ² stranded orange wire	30 A

Wire length, color and diameter can be customized upon request. Customization requires minimum order quantities depending on nature of modifications. Please contact your sales representative for details.

INLINE SPLASHPROOF FUSE HOLDER

for ATO® Style Blade Fuse

RoHS



Description

Used with ATO® / FKS Fuse. Supplied with two 4" / 102mm wire leads. Includes protective cover for harsh environment.

Ordering Information

Part Number	Package Size
FHAC0001ZXJ	1000
FHAC0002ZXJ	1000

Dimensions

Dimensions in mm

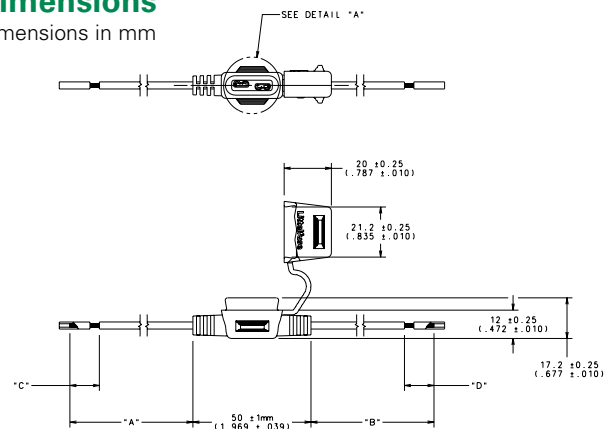

Ratings

Part Number	Description	Fuse Rating
FHAC0001ZXJ	16AWG/1.3mm ² stranded black wire	20 A
FHAC0002ZXJ	12AWG/3.3mm ² stranded orange wire	30 A

Wire length, color and diameter can be customized upon request. Customization requires minimum order quantities depending on nature of modifications. Please contact your sales representative for details.

ADD-A-CIRCUIT MINI® STYLE



Description

Extension board for an additional fuse protected tap from an existing MINI size socket. The 2 fuses for the existing and the new circuit are oriented horizontally.

Ordering Information

Part Number	Package Size
0FHM0200Z	50
0FHM0200S	20

Ratings

Part Number	Description	Fuse Rating
0FHM0200_	Fusetap and holder for installing additional accessories without splicing	10 A

ADD-A-CIRCUIT ATO® STYLE

RoHS



Description

Extension board for an additional fuse protected tap from an existing ATO size socket. The 2 fuses for the existing and the new circuit are oriented horizontally.

Ordering Information

Part Number	Package Size
0FHA0200Z	50
0FHA0200S	20

Ratings

Part Number	Description	Fuse Rating
0FHA0200_	Fusetap and holder for installing additional accessories without splicing	10 A

FUSE HOLDER FOR MAXI® STYLE BLADE FUSE

RoHS



Description

This fuse holder provides an efficient, simple installation method for MAXI® / FK3-Style Fuse applications.

Ordering Information

Part Number	Package Size
01520001TXN	10
01520001U	500

Dimensions

Dimensions in mm

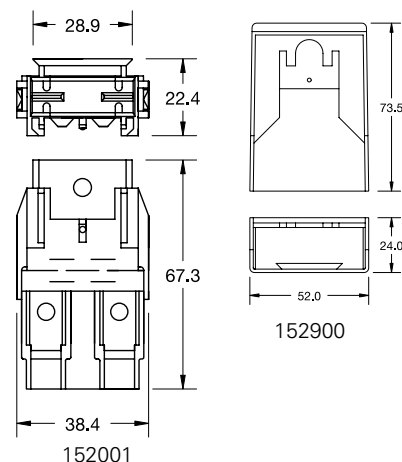

Ratings

Part Number	Description	Fuse Rating
01520001TXN940	Assortment: Fuse Holder with screws and terminals - 10 pcs.	60 A
01520001TXN941	Assortment: Fuse Holder, Cover with screws and terminals - 10 pcs.	60 A

MAXI® COMPONENTS

Ratings

Part Number	Description
01520001_	Fuse Holder
01520900_	Cover
09130653_	Terminals for wire Ø 2.5 - 6 mm ²
09130654_	Terminals for wire Ø 5 - 10 mm ²
09130550_	Screws Ø 5.3 mm, M 5x8

Ordering Information

Part Number	Package Size
01520001TXN	10
01520900TXN	10
01520900H	100
01520900U	500
09130550LXN	50
09130550Z	1
09130653LXN	50
09130653Z	1500
09130654LXN	50
09130654Z	1000

SPLASH RESISTANT FUSE HOLDER

for MAXI® Style Blade Fuse

RoHS



Description

The Inline Splash Resistant Fuse Holder provides an efficient, simple installation method for MAXI® / FK3-style fuse applications in harsh under-the-hood environments

* PA66-GF30: heat resistant
UL 94-V0: self extinguishing

Ordering Information

Part Number	Package Size
01520003TXN	10
279.6800.0001	10
279.6800.0002	100
01520003U	500

Dimensions

Dimensions in mm

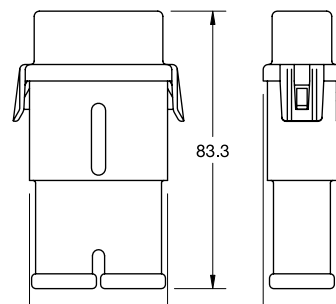

Ratings

Part Number	Description	Fuse Rating
01520003TXN941	Assortment: Fuse Holder 01520003 with terminals, seals and cover for 4-6mm ² - 10 pcs.	60 A
01520003TXN942	Assortment: Fuse Holder 01520003 with terminals, seals and cover for 6-10mm ² - 10 pcs.	60 A
279.6850.0402	Assortment: Fuse Holder 279.6800.000 with terminals, seals and cover for 4mm ² - 10 pcs.	80 A
279.6850.0602	Assortment: Fuse Holder 279.6800.000 with terminals, seals and cover for 6-10mm ² - 10 pcs.	80 A
279.6850.1602	Assortment: Fuse Holder 279.6800.000 with terminals, seals and cover for 16mm ² - 10 pcs.	80 A

SPLASH RESISTANT MAXI® COMPONENTS

Ratings

Part Number	Description	Fuse Rating
279.6800.000_	Fuse Holder UL 94-V0 *	80 A
01520003_	Fuse Holder PA66-GF30*	-
01520903_	Cover	-
0913726001	Loose terminals for wire Ø 2.5 - 4 mm ² - 300 pcs	-
09130726TXN	Loose terminals for wire Ø 2.5 - 4 mm ² - 10 pcs	-
0913727001	Loose terminals for wire Ø 4 - 6 mm ² - 300 pcs	-
09130727TXN	Loose terminals for wire Ø 4 - 6 mm ² - 10 pcs	-

Ratings

Part Number	Description	Fuse Rating
0913728001	Loose terminals for wire Ø 6 - 10 mm ² - 300 pcs	-
09130728TXN	Loose terminals for wire Ø 6 - 10 mm ² - 10 pcs	-
868-905	Wire seals for wire Ø 2.5 - 6 mm ² , bulk - 1000 pcs	-
08680905TXN	Wire seals for wire Ø 2.5 - 6 mm ² - 10 pcs	-
868-906	Wire seals for wire Ø 6 - 10 mm ² , bulk - 1000 pcs	-
08680906TXN	Wire seals for wire Ø 6 - 10 mm ² - 10 pcs	-

INLINE FUSE HOLDER FOR MAXI® STYLE BLADE FUSE



Description

Supplied with two 5" leads - 6 gauge wire for up to 60A MAXI®/FK3 Fuse applications, this Inline Fuse Holder also provides a protective cover for harsh under-the-hood environments. Mounting hole also permits easy bulkhead installation.

Ordering Information

Part Number	Package Size
MAHC0001ZXJ	100
MAHC0001TXJ	10

Dimensions

Dimensions in mm

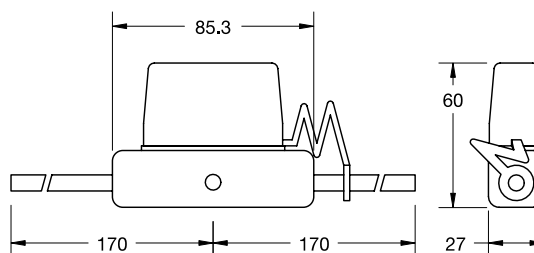

Ratings

Part Number	Description	Fuse Rating
MAHC0001ZXJ	6AWG black wire	60 A

INLINE FUSE HOLDER FOR JCASE® STYLE FUSES

RoHS



Specifications

Maximum Voltage Rating:	58V
Maximum Current Rating:	See table below.
Cable Insulation	GXL, 125°C
Operating Temperature Range:	-40°C to +125°C
Max. Fuse Insertion Force:	49N

Ordering Information

Part Number	Package Size
0FHJxxxxG	250
FHJCxxxxG	250
HLJCxxxxG	250
0FHJxxxxL	50
FHJCxxxxL	50
HLJCxxxxL	50

Description

This product is an Inline fuse holder for use with either standard or Low Profile JCASE® fuses, 20A - 60A. It offers size and weight savings compared to MAXI® fuseholders, and has an optional protective cover for splash resistance. Standard product will have two 102mm red wire leads. Wire length and insulation color can be customized upon request. Tinned wires also available upon request. All customizations have minimum order requirements. Contact Littelfuse sales representative for details.

There are two available mounting options: One version with mounting brackets, and one without.

Ratings

Part Number	Description	Cover	Mounting	Wire Size	Fuse Rating
0FHJ1001_	Standard JCASE Holder	None	Standard Thru-Hole	10AWG	40 A max
0FHJ1002_	Standard JCASE Holder	None	Standard Thru-Hole	8AWG	60 A max
0FHJ2001_	Standard JCASE Holder	None	Mounting Bracket	10AWG	40 A max
0FHJ2002_	Standard JCASE Holder	None	Mounting Bracket	8AWG	60 A max
FHJC1001_	Standard JCASE Holder	Yes	Standard Thru-Hole	10AWG	40 A max
FHJC1002_	Standard JCASE Holder	Yes	Standard Thru-Hole	8AWG	60 A max
FHJC2001_	Standard JCASE Holder	Yes	Mounting Bracket	10AWG	40 A max
FHJC2002_	Standard JCASE Holder	Yes	Mounting Bracket	8AWG	60 A max
HLJC1001_	Low Profile JCASE Holder	Yes	Standard Thru-Hole	10AWG	40 A max
HLJC1002_	Low Profile JCASE Holder	Yes	Standard Thru-Hole	8AWG	40 A max
HLJC2001_	Low Profile JCASE Holder	Yes	Mounting Bracket	10AWG	40 A max
HLJC2002_	Low Profile JCASE Holder	Yes	Mounting Bracket	8AWG	40 A max

INLINE FUSE HOLDER FOR JCASE® STYLE FUSES

RoHS

Dimensions

Dimensions in mm

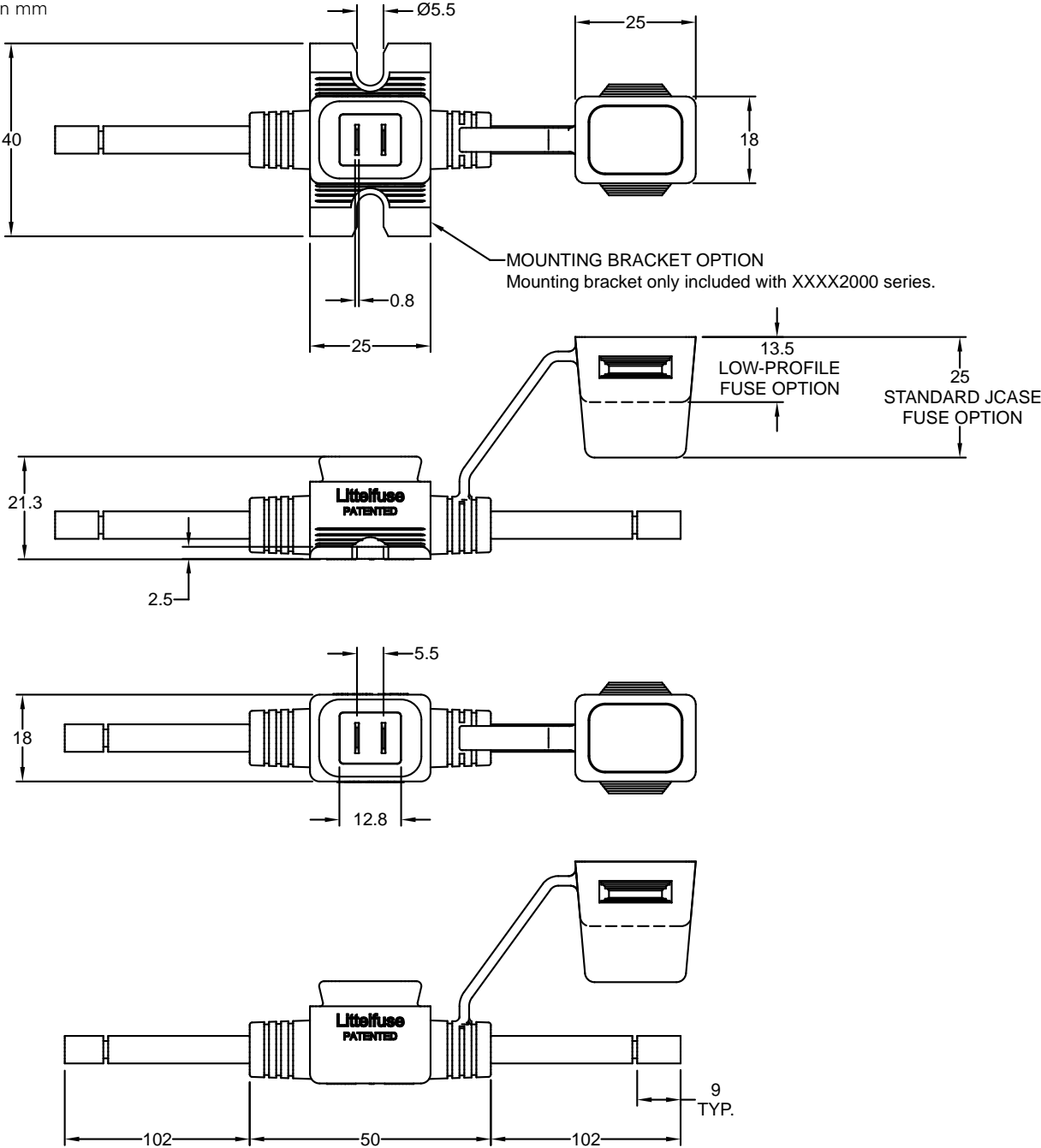

PCB Fuse Holders



PCB Mount Fuse Holder for MINI[®] Style Blade Fuse	143
PCB Mount Fuse Holder for MINI[®] Style Blade Fuse (125V)	145
FLR PCB Fuse Holder for ATO[®] Style Blade Fuse Rated 80V	146
FLR PCB Fuse Holder for ATO[®] Style Blade Fuse Rated 58V	147
FKH Fuse Holder with 90° Connection for ATO[®] Style Blade Fuse Rated 80V	148
PCB Fuse Clip for ATO[®] Style Blade Fuse	149

PCB MOUNT FUSE HOLDER FOR MINI® STYLE BLADE FUSE



Description

The MINI® Fuse PCB Fuse Holders bring the reliability and availability of the plug-in 32V MINI® Fuse to the circuit board. Vertical and horizontal mounting of units is offered. The Fuse Holder has “standoffs” to accommodate board washing and incorporates a unique “board lock” anchor to maintain a firm mechanical bond to the PCB.

UL 15A CSA 10A (32V)

Part Number	Description	Fuse Rating
01530007_	Horizontal Mount	15 A
01530031_		20 A
01530008_	Single vertical Mount (or End Unit)	15 A
01530032_		20 A
01530009_	Stackable vertical Mount	15 A
01530033_		20 A

Ordering Information

Part Number	Package Size
015300xLXN	50
015300xZ	500
01530033xZ	5000

0153007_

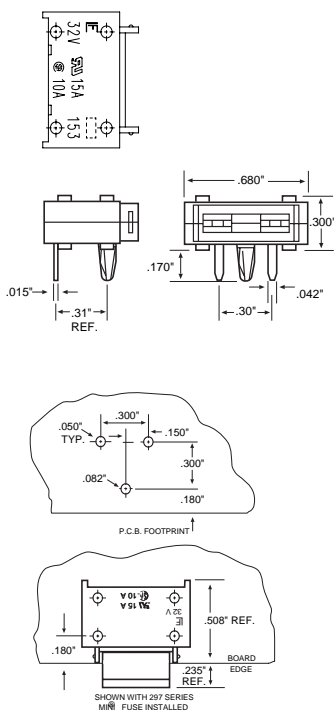

0153031_

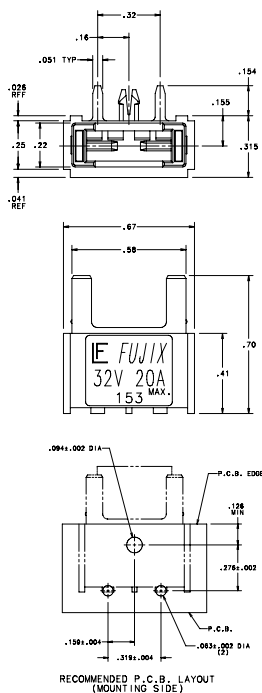

0153008_

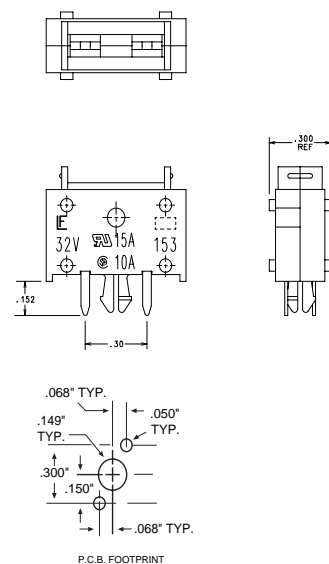

PCB MOUNT FUSE HOLDER FOR MINI® STYLE BLADE FUSE



0153009_

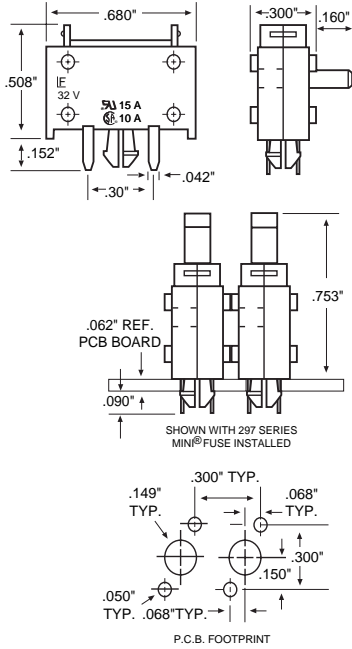

0153032_

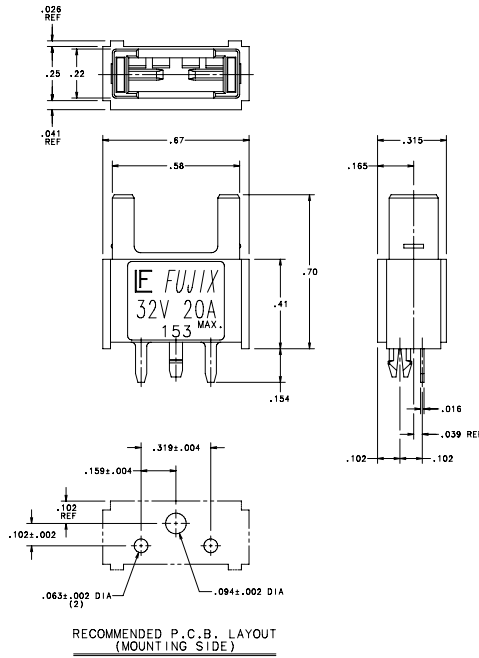

0153033_

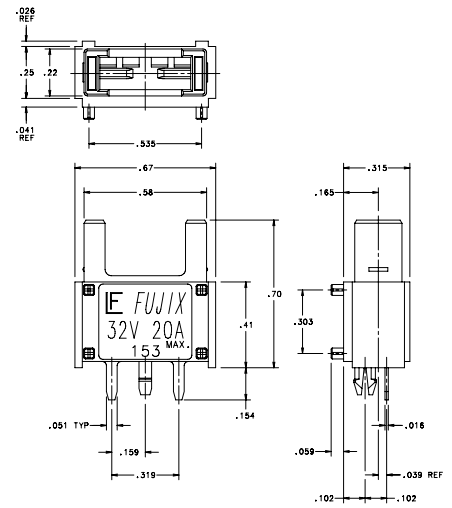

PCB MOUNT FUSE HOLDER FOR MINI® STYLE BLADE FUSE

RATED 125V

RoHS



Specifications

Housing: Out of thermoplastic (UL 94-V0, heat-resistant)
 Connections: Leaf spring connector systems, copper alloy, tinned
 Color: Black

Ordering Information

Part Number	Package Size
178.6764.0001	100

Description

Fuse holder for MINI/ FK1 fuses for PCB applications. The FL1 Fuse Holder can be mounted in a row of nearly any number. The terminals fit into a 7.62 mm pitch.

Dimensions

Dimensions in mm

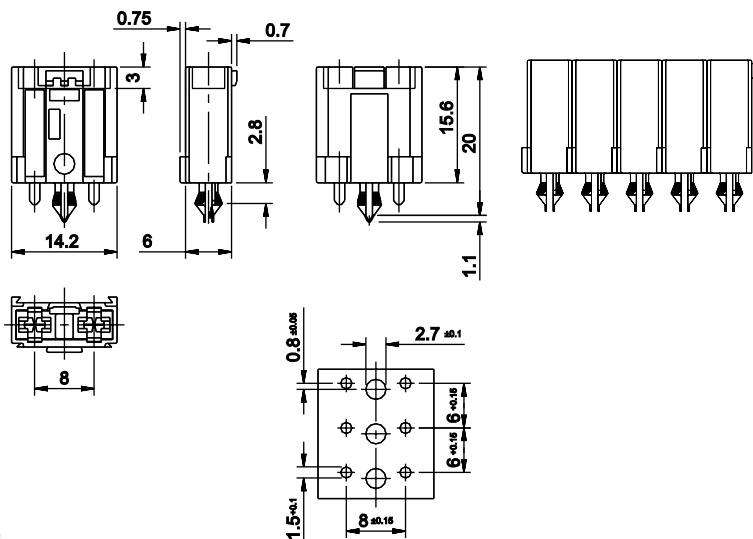

Ratings

Part Number	Description	Contact Temperature
178.6764.0001	Complete	max. 130°C

The FL1-Fuse Holder can be mounted in a row in nearly any number. The terminals of the holder will also fit into a 7.62 mm pitch.

FLR PCB FUSE HOLDER FOR ATO® STYLE BLADE FUSE RATED 80V

RoHS



Description

PCB Fuse Holder for ATO / FKS size fuse-links. For through hole soldering. Rated voltage 80V.

Specifications

Housing: Out of thermoplastic (UL 94-V0, heat-resistant)
 Connections: Leaf spring connector systems, soldering terminals (4 pins each), copper alloy, silver plated
 Color: Black

Ordering Information

Part Number	Package Size
178.6165.xxx1	100
178.6165.xxx2	500

Dimensions

Dimensions in mm

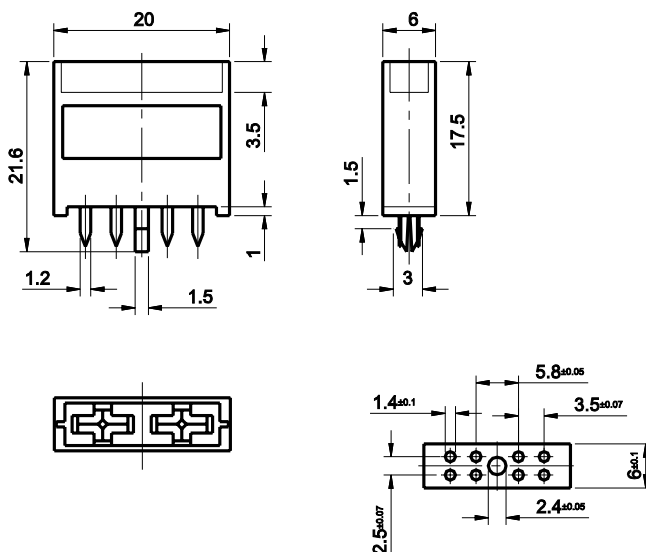

Ratings

Part Number	Description	Contact Temperature
178.6165.000_	Complete	max. 130°C

Corresponding fuse links see Section "Blade Fuses."

FLR PCB FUSE HOLDER FOR ATO® STYLE BLADE FUSE RATED 58V

RoHS



Specifications

Housing: Out of thermoplastic (UL 94-V0, heat-resistant)
 Connections: Leaf spring connector systems, soldering terminals
 (4 pins each), copper alloy, tinned
 Color: Black

Ordering Information

Part Number	Package Size
178.4265.0002	500

Dimensions

Dimensions in mm

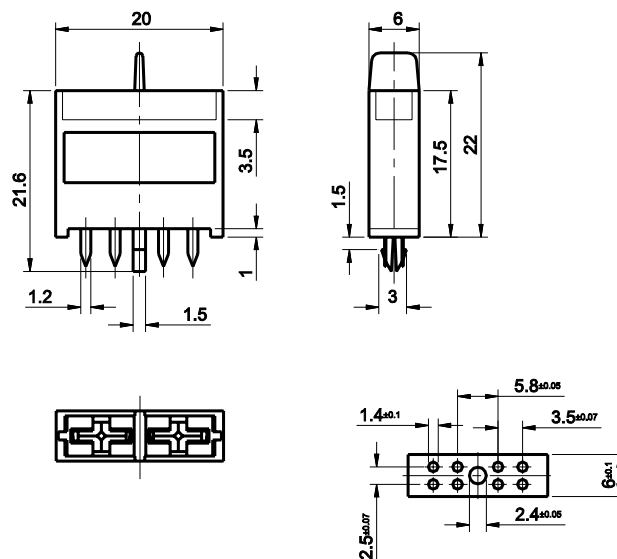

Description

PCB Fuse Holder for 42V PowerNet with coding for TAC fuses-links. For through hole soldering. Rated voltage 58V.

Ratings

Part Number	Description	Contact Temperature
178.4265.0002	Complete	max. 130°C

Corresponding fuse links see Section "Blade Fuses."

FKH FUSE HOLDER WITH 90° CONNECTION

for ATO® Style Blade Fuse Rated 80V

RoHS



Description

Fuse Holder for ATO® / FKS size fuses-links. 90° bended solderable tin plated contacts. Rated voltage 80V.

Specifications

Housing: Out of thermoplastic (UL 94-V0, heat-resistant)
 Connections: Leaf spring connector systems, soldering contacts (2 pins), copper alloy, tinned
 Color: Black

Ordering Information

Part Number	Package Size
178.7017.0001	100

Dimensions

Dimensions in mm

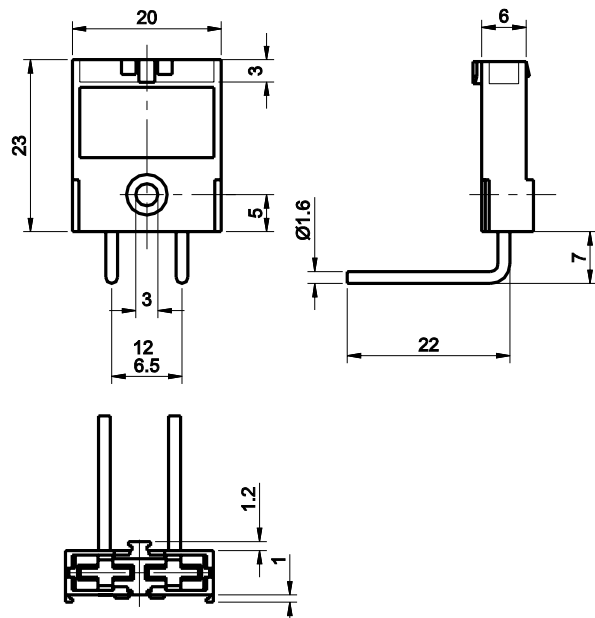

Ratings

Part Number	Description	Contact Temperature
178.7017.0001	Complete	max. 130°C

Corresponding fuse links see Section "Blade Fuses."

Stackable and Panel Mount Fuse Holders



Stackable Panel Mount Fuse Holder with Wire Leads for ATO® Style Blade Fuse	150
ATO® Panel Mount Holder Components	150
Snap Mount Fuse Holder for ATO® Style Blade Fuse	151
Stackable Panel Mount Fuse Holder for ATO® Style Blade Fuse	151
Panel-Mount Stackable Components	152
FH2 Stackable Block Fuse Holder for ATO® Style Blade Fuse Rated 80V	153
FH2 Stackable Block Fuse Holder for TAC® Style Blade Fuse Rated 58V	154
FKH Stackable Fuse Holder for ATO® Style Blade Fuse Rated 58V	155
FKH Stackable Fuse Holder for ATO® Style Blade Fuse Rated up to 80V	156
Low Profile JCASE® Panel-Mount Fuse Holder	157

STACKABLE PANEL MOUNT FUSE HOLDER

with Wire Leads for ATO® Style Blade Fuse



Description

Intended for use with 32V ATO®/ FKS Fuses rated up to 20A or 30A.

Ordering Information

Part Number	Package Size
01550xxxLXN	50
01550xxxZ	100

Dimensions

Dimensions in mm

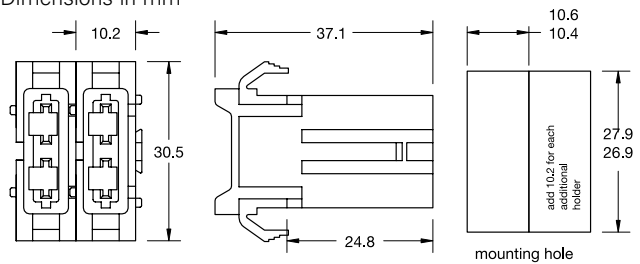

Ratings

Part Number	Description	Fuse Rating
01550300_	14AWG/2.1mm ² stranded black wire	20 A
01550400_	10AWG/5.3mm ² stranded orange wire	30 A

ATO® PANEL MOUNT HOLDER COMPONENTS



Dimensions

Dimensions in mm

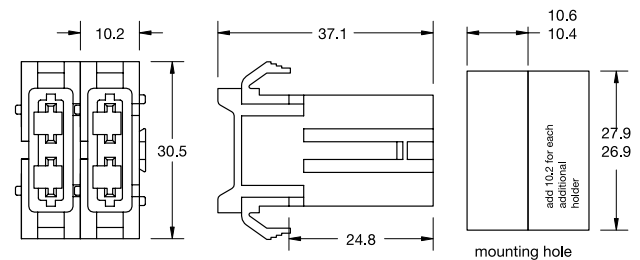

Ratings

Part Number	Description	Fuse Rating
868-062-000	Housing only, color black - 2700 pcs.	-
913-008	Reeled Terminals A, wire 14AWG/2.1mm ² -6000 pcs.	20A
913-008-001	Singe Terminals A, wire 14AWG/2.1mm ² -1000 pcs.	20A
913-007	Reeled Terminals B, wire 10AWG/5.3mm ² - 5000 pcs.	30A
913-007-001	Singe Terminals B, wire 10AWG/5.3mm ² -1000 pcs.	30A

SNAP MOUNT FUSE HOLDER

for ATO® Style Blade Fuse



Description

Intended for use with 32V ATO / FKS Fuses rated up to 20A.

Ordering Information

Part Number	Package Size
01510001LXN	50
01510001F	200

Dimensions

Dimensions in mm

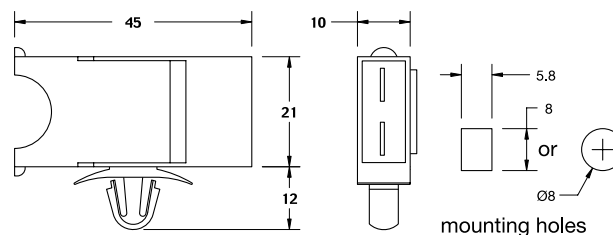

Ratings

Part Number	Description	Fuse Rating
01510001_	Snap-mount holder assembled, color black	20 A

STACKABLE PANEL MOUNT FUSE HOLDER

for ATO® Style Blade Fuse



Description

Intended for use with 32V ATO / FKS Fuses rated up to 20A.

Dimensions

Dimensions in mm

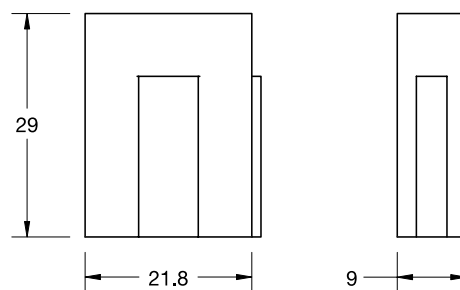

Ratings

Part Number	Description	Fuse Rating
08680900LXN	Assortment: Holders with brackets and terminals, color black - 50 pcs	20 A

PANEL-MOUNT STACKABLE COMPONENTS



Dimensions

Dimensions in mm

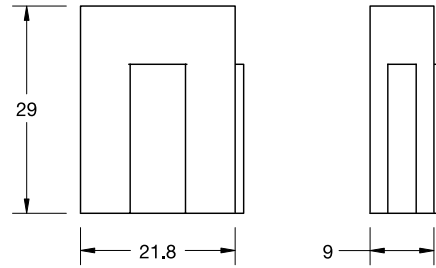

Ratings

Part Number	Description	Fuse Rating
868-900-010RM	Holder only, color black - 100 pcs.	-
868-900-020RM	Brackets only, color black - 100 pcs.	-
09130900Z	Terminals loose, wire 0.5 - 1.25 mm ² - 200 pcs.	-

FH2 STACKABLE BLOCK FUSE HOLDER

for ATO® Style Blade Fuse Rated 80V

RoHS



Description

Blockholder for ATO / FKS size fuses-links. Attachable in X- and Y-direction. Rated voltage 80V; crimp terminals.

Chart for row-mounting

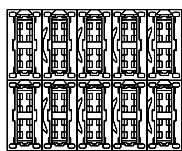

10er/pcs. Block

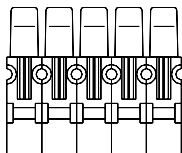

Specifications

Housing: Out of thermoplastic (UL 94-V0, heat-resistant)
 Connections: Leaf spring connector systems, crimp contacts, copper alloy, tinned
 Color: Black
 Cover: Thermoplastic (transparent)

Ordering Information

Part Number	Package Size
178.6105.0001	100
178.6105.0002	1000
178.6115.0001	100
178.6115.0002	1000

Dimensions

Dimensions in mm

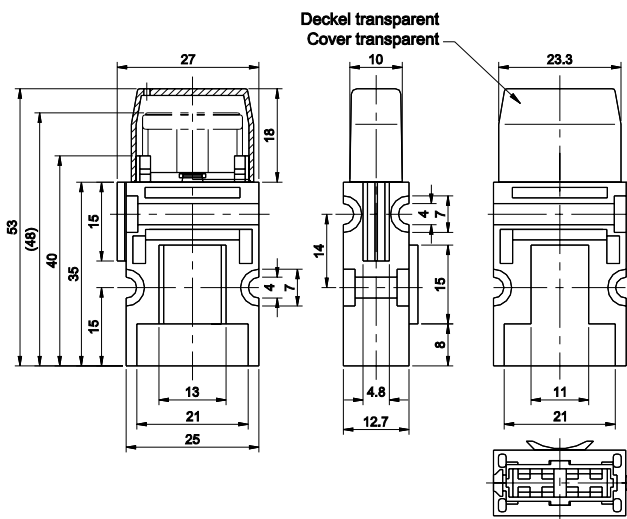

Ratings

Part Number	Description	Contact Temperature
178.6105.000_	Complete with DFK 1.5 - 2.5 mm ²	max. 130°C
178.6115.000_	Housing	-
178.6125.000_	Cover	-
178.6116.100_*	DFK-Kontakte 0.5-1.0mm ²	max. 130°C
178.6116.250_*	Contacts 1.5-2.5mm ²	max. 130°C
178.6116.600_*	Contacts 4.0-6.0mm ²	max. 130°C

* Crimping tool available on request.
 Corresponding fuse links see Section "Blade Fuses."

FKH STACKABLE FUSE HOLDER

for ATO® Style Blade Fuse Rated 58V

RoHS



Specifications

Housing + Adapter: Out of thermoplastic (UL 94-V0, heat-resistant)
 Connections: Leaf spring connector systems, soldering terminals (4 pins each), copper alloy, tinned
 Color: Black

Ordering Information

Part Number	Package Size
178.4250.0002	1000
178.4252.0002	1000
178.6116.xxx1	200
178.6116.xxx2	1000
178.619x.0001	100

Description

Fuse Holder for 42V PowerNet with coding for TAC fuses-links. Attachable in X - direction. Rated voltage 58V; crimp terminals.

Dimensions

Dimensions in mm

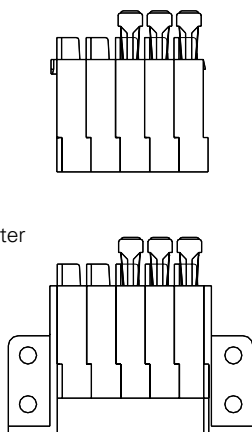
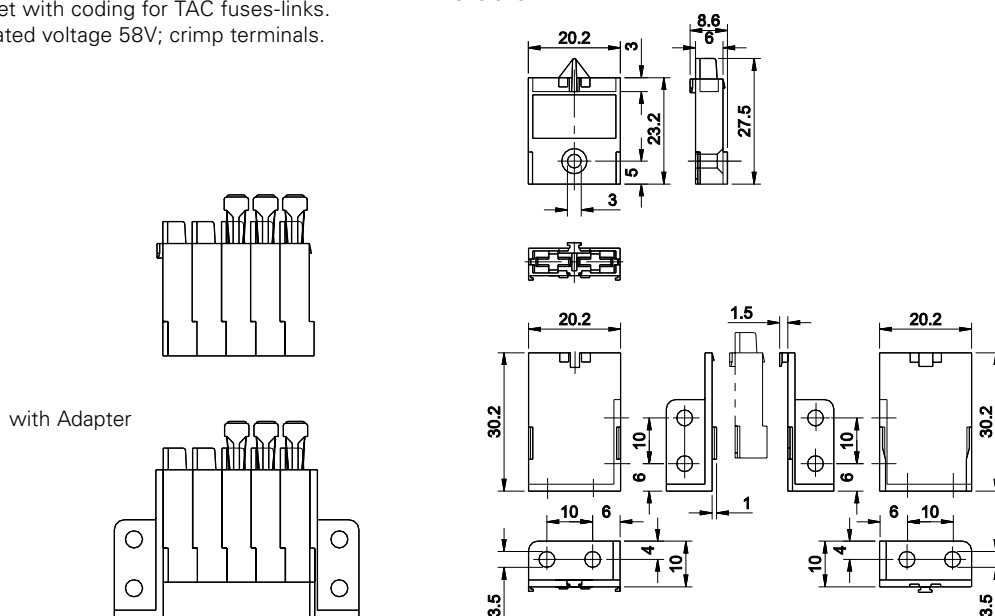

with Adapter

Ratings

Part Number	Description	Contact Temperature
178.4252.0002	Complete	max. 130°C
178.4250.0002	Housing	-
178.6116.250_	Contacts 1.5 - 2.5 mm ²	max. 130°C
178.6191.0001	Adapter right	-
178.6192.0001	Adapter left	-

Corresponding fuse links see Section "Blade Fuses."
 This FKH 58V Fuse Holder can be mounted in row in any number. The fixing adapters are not included in the Fuse Holder. Please order the adapter separately.

FKH STACKABLE FUSE HOLDER

for ATO® Style Blade Fuse Rated up to 80V

RoHS



Description

Fuse Holder for ATO® / FKS size fuses-links. Attachable in X - direction. Rated voltage up to 80V; crimp terminals.

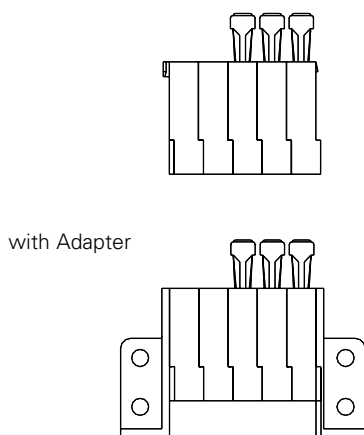

Specifications

Housing + Adapter: Out of thermoplastic (UL 94-V0, heat-resistant)
 Connections: Leaf spring connector systems, soldering terminals, copper alloy, tinned
 Color: Black

Ordering Information

Part Number	Package Size
178.6152.0001	100
178.6150.0001	1000
178.6116.xxx1	200
178.6116.xxx2	1000
178.619x.0001	100

Dimensions

Dimensions in mm

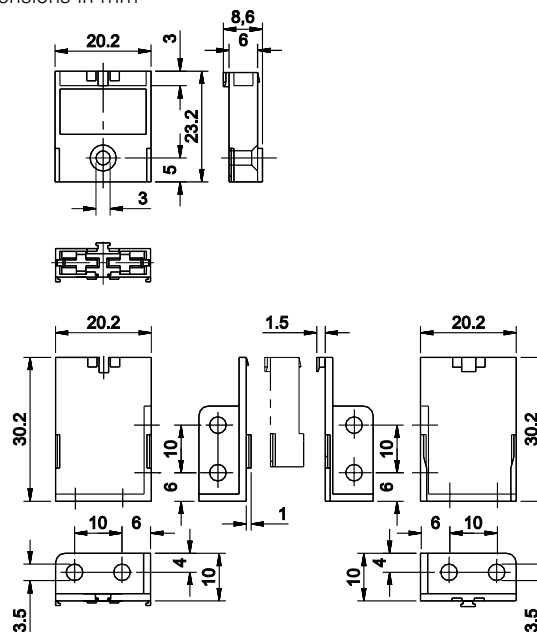

Ratings

Part Number	Description	Contact Temperature
178.6152.000_	Complete with terminals	max. 130°C
178.6150.000_	Housing Only	-
178.6116.250_	Terminals of 1.5 - 2.5 mm ²	max. 130°C
178.6152.250_	With 200 mm of 2.5 mm ² wire loop	-
178.6191.0001	Adapter right	-
178.6192.0001	Adapter left	-

Corresponding fuse links see Section "Blade Fuses."

This FKH-Fuse Holder can be mounted in row in any number. The fixing adapters are not included in the Fuse Holder. Please order the adapter separately.

LOW PROFILE JCASE® PANEL-MOUNT FUSE HOLDER

RoHS



Description

Used with LP JCASE® fuses up to 40A. Holder will use 12 AWG / 3 mm² wire. Fuse not included.

Dimensions

Dimensions in mm

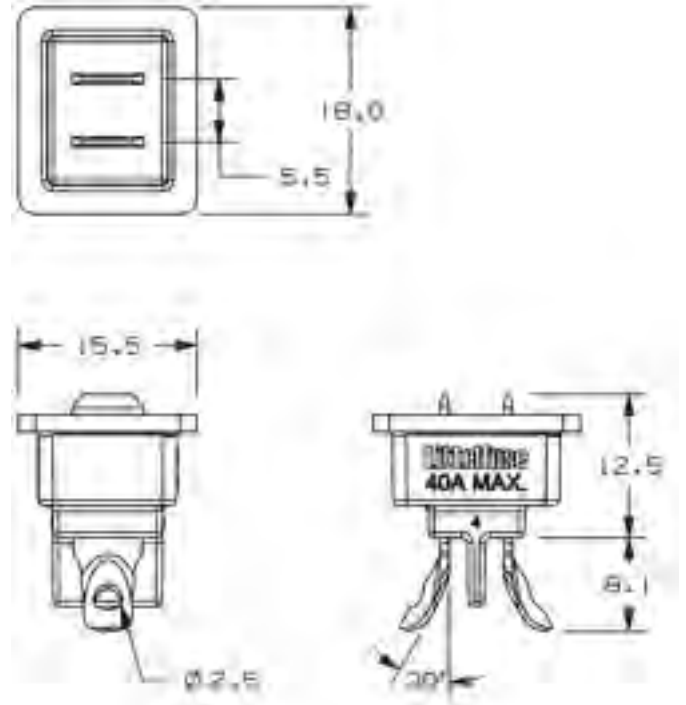

Ratings

Part Number	Description	Fuse Rating
0FHJ3003U	Low Profile JCASE® Holder with soldering tabs	40 A max

Bolt-Down Fuse Holders & Assemblies



Fuse Holder for MIDI®/BF1 Style Fuse	159
MIDI®/BF1 2 & 3-Way Fuse Holder	159
Inline MIDI® Fuse Holder	160
Bolt-Down Fuse Holders for MEGA® Style Fuse	161
Splash Resistant Fuse Holder for MEGA® Style Bolt-Down Fuse	161
MEGA®-FLEX Holder for MEGA® Fuses	162
Fuse Base for Fuse Strips Rated 80V for Single	164
Fuse Base for Fuse Strips Rated 80V for Double	165
Battery Clamp for CF8 Fuse Rated 58V	166
Insulating Nuts for CF8 Fuse	167

FUSE HOLDER FOR MIDI®/BF1 STYLE FUSE

RoHS



Dimensions

Dimensions in mm

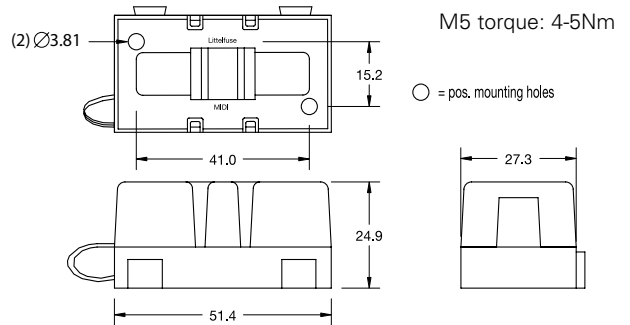

Description

Use with BF1 /MIDI® fuses up to 200A. Includes protective cover. Features interconnecting pins on side of fuse block for secure multiple block configurations. Includes M5 threaded studs and hex nuts with lock washers. Fuse not included.

Ratings

Part Number	Description	Fuse Rating
04980900ZXT	330 pcs.	200 A
04980903ZXT	Holder with mounting brackets - 264 pcs.	200 A

Corresponding fuses see Section "Bolt-Down Fuses."

MIDI®/BF1 2 & 3-WAY FUSE HOLDER

RoHS



Dimensions

Dimensions in mm

M5 torque: 5Nm

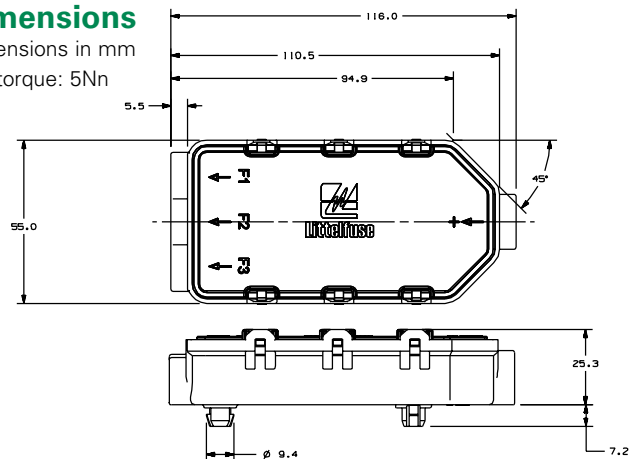

Ratings

Part Number	Description	Fuse Rating
0HBF0001ZXBASE3	Holder complete for 3 way (includes M5 bolts & cover seal)	200 A
0HBF0001ZXBASE2	Holder complete for 2 way (includes M5 bolts & cover seal)	200 A
0HBF0001ZXCOVER	Cover	-

Description

This splash-resistant fuse holder with cover can be flexible enough to be used with 2 or 3 MIDI® fuses. A Snap-on fixes the sheet metals in the holder. The holder includes M5 threaded bolts and cover seal. Busbar and cable seals are optional. Fuse not included.

INLINE MIDI® FUSE HOLDER

RoHS



Specifications

Max. Voltage Rating:	32 VDC
Max. Fuse Rating:	200A
Operating Temperature Range:	-40°C to +125°C
Max. Wire Size:	20mm ²
M5 Torque Rating:	5Nm
Base/Cover Material:	UL 94V-0 glass-filled nylon
M5 Bolt Material:	Zinc-plated
M5 Nuts:	Zinc-plated with nylock inserts

Dimensions

Dimensions in mm

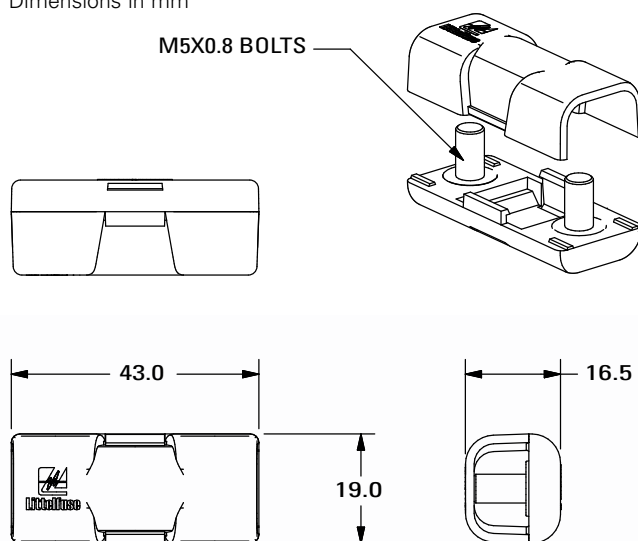

Description

The Inline MIDI® fuseholder is designed for use with bolt-down MIDI® style fuses. It may be installed directly inline with the cables with no mounting required.

The Inline MIDI® fuse holder can be used with heat shrink tubing for applications requiring more splash resistance. The curved design of the cover aids in prevention of tube-splitting during application.

Ratings

Part Number	Description
04980921GXM5	Assembly with hardware and cover installed (Zinc-plated steel)
498921-1	Cover-only
498921-2	Base only with hardware installed (Zinc-plated steel)

BOLT-DOWN FUSE HOLDERS FOR MEGA® STYLE FUSE

RoHS



Description

Use with MEGA® fuses up to 500A. Ideal for battery and alternator connections and other heavy gauge cables requiring ultra high current protection. Includes protective cover. Features interconnecting pins on side of fuse block for secure multiple block configurations. Includes M8 threaded studs and hex nuts with lock washers. Fuse not included.

Dimensions

Dimensions in mm

M8 torque: 12-18Nm

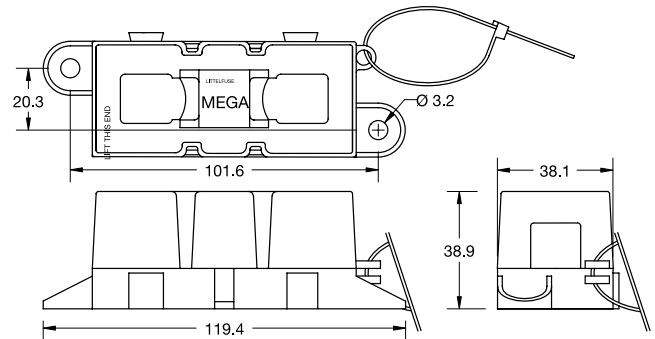

Ratings

Part Number	Description	Fuse Rating
02981001ZXT	160 pcs.	500 A

Corresponding fuses see Section "Bolt-Down Fuses."

SPLASH RESISTANT FUSE HOLDER

for MEGA® Style Bolt-Down Fuse



Description

For use with MEGA® fuses the holder offers splash-resistant protection for use in harsh environments.

Dimensions

Dimensions in mm

M8 torque: 12-18Nm

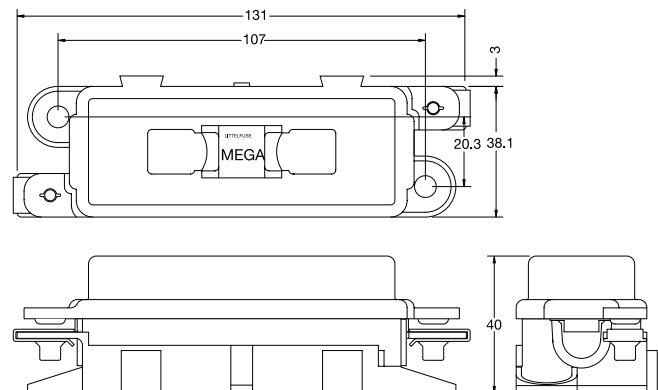

Ratings

Part Number	Description	Fuse Rating
298907-030	Holder	250 A
298907-040	Cover	-

Corresponding fuses see Section "Bolt-Down Fuses."

MEGA®-FLEX HOLDER FOR MEGA® FUSES

RoHS



Specifications

Max. Voltage Rating:	32 VDC
Max. Current Rating:	500A
Operating Temperature Range:	-40°C to +125°C
Wire Size:	70 - 8 mm ²
Recommended Fuse Installation Torque:	12 - 18Nm
Recommended Mounting (using M6 Screw/Washer):	5Nm
Base Material:	UL94V0 Glass-filled PPA
Cover Material:	UL94V0 Elastomer

Description

The MEGA®-FLEX fuse holder is used with the MEGA® style bolt-down fuse, which is available up to 500A. This holder offers a flexible cover, which allows cable entry from virtually any direction, large wire size, and ring terminal stack up. Slots on the base allow holder to be mounted with tie wraps. Dovetail features allow you to interlock multiple MEGA®-FLEX fuse holders together for a high power distribution block. Bus bars are available for multiple holder applications.

Ratings

Part Number	Description	Material (Studs and hardware)
02981028HXFCB	Base-only (No Hardware)	Zinc-Plated Steel
02981028HXFCC	Cover-only	-
02981028HXFC	Assembly	Zinc-Plated Steel
02981028HXFC-SS	Assembly	Stainless Steel
882-839-2	2-Position bus Bar	Tin-Plated Copper
882-839-3	3-Position bus Bar	Tin-Plated Copper
882-839-4	4-Position bus Bar	Tin-Plated Copper
882-839-5	5-Position bus Bar	Tin-Plated Copper

MEGA[®]-FLEX HOLDER FOR MEGA[®] FUSES

RoHS

Dimensions

Dimensions in mm

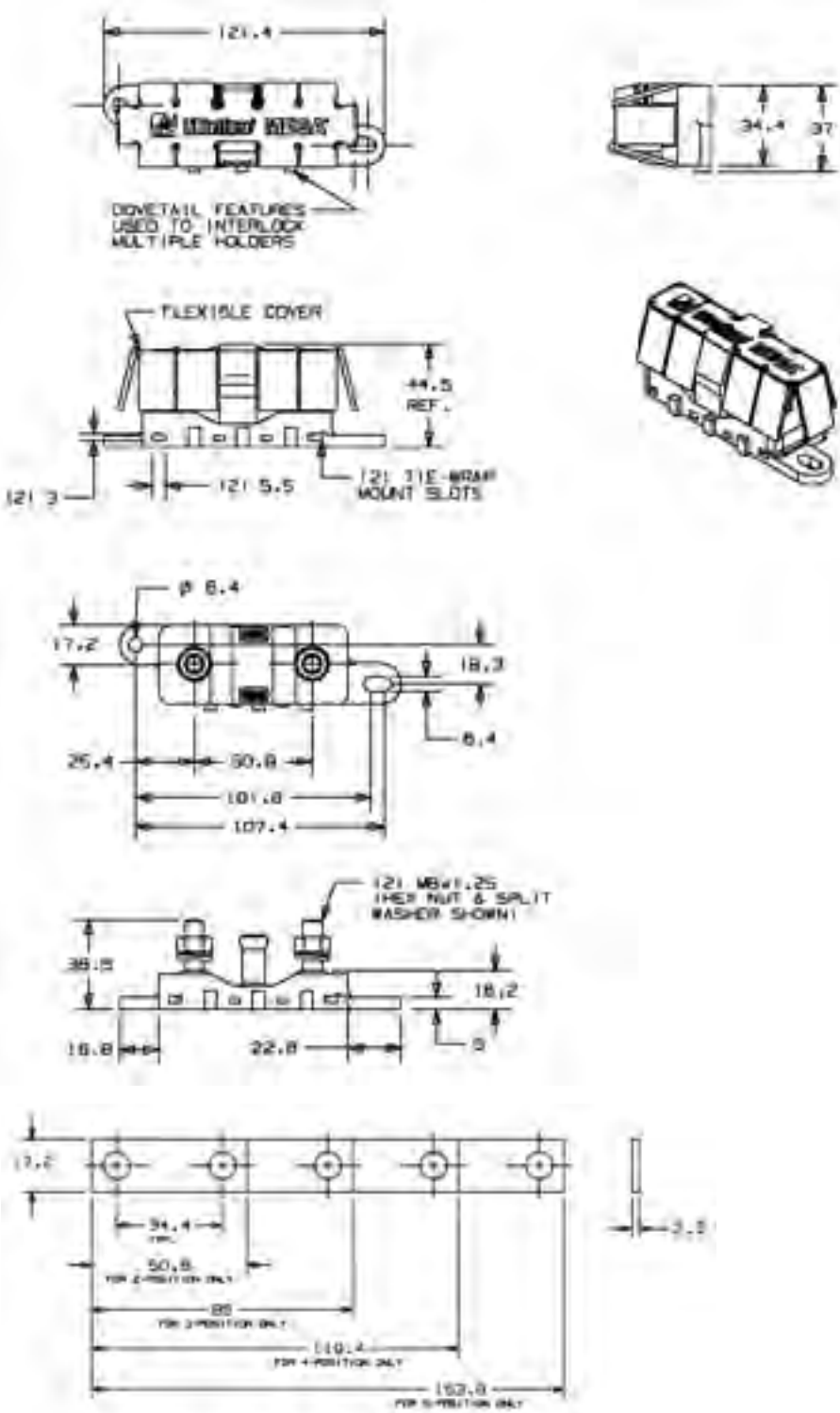

FUSE BASE FOR FUSE STRIPS RATED 80V FOR SINGLE

RoHS



Specifications

Base: Insulation material according to DIN 7708/1
Spring washer according ISO 4036
Hexagon nuts according to DIN 439
Washer according to DIN 125

Conducting Materials: Copper wrought alloy

Color: Black

Ordering Information

Part Number	Package Size
177.57xx.0001	10
192.5710.0001	10

Description

Fuse base for fuse strips with 62 mm spacing. Up to 80V.

Dimensions

Dimensions in mm

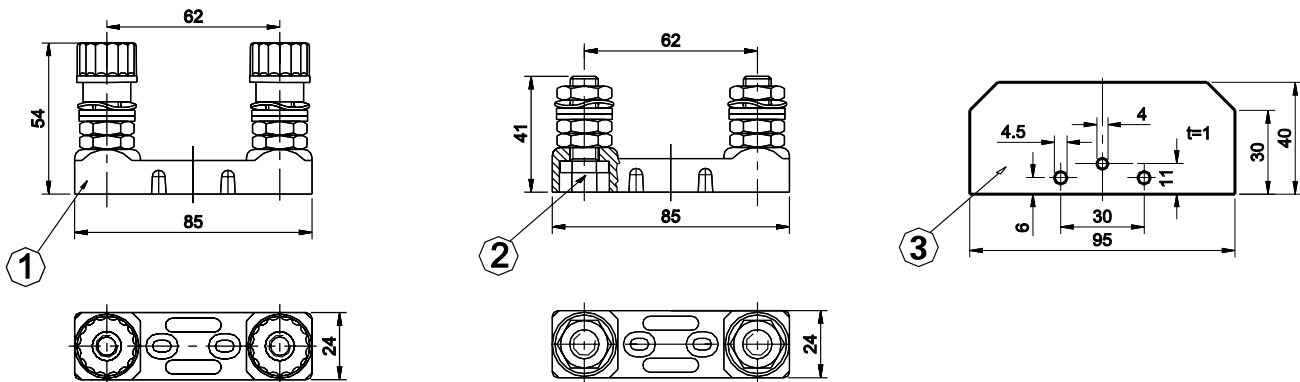

Ratings

Part Number	Description	Contact Temperature
177.5701.0001	1) Fuse base	max. 425 A
177.5731.0001	2) Fuse base	max. 425 A
192.5710.0001	3) Phase barrier	-

Corresponding fuse strips see Section "Bolt-Down Fuses."

FUSE BASE FOR FUSE STRIPS RATED 80V FOR DOUBLE

RoHS



Specifications

Base: Insulation material according to DIN 7708/1
Spring washer according ISO 4036
Hexagon nuts according to DIN 439
Washer according to DIN 125

Conducting Materials: Copper wrought alloy

Color: Black

Ordering Information

Part Number	Package Size
177.57xx.0001	10
192.57xx.0001	10

Description

Fuse base for fuse strips with 62 mm spacing. Up to 80V.

Dimensions

Dimensions in mm

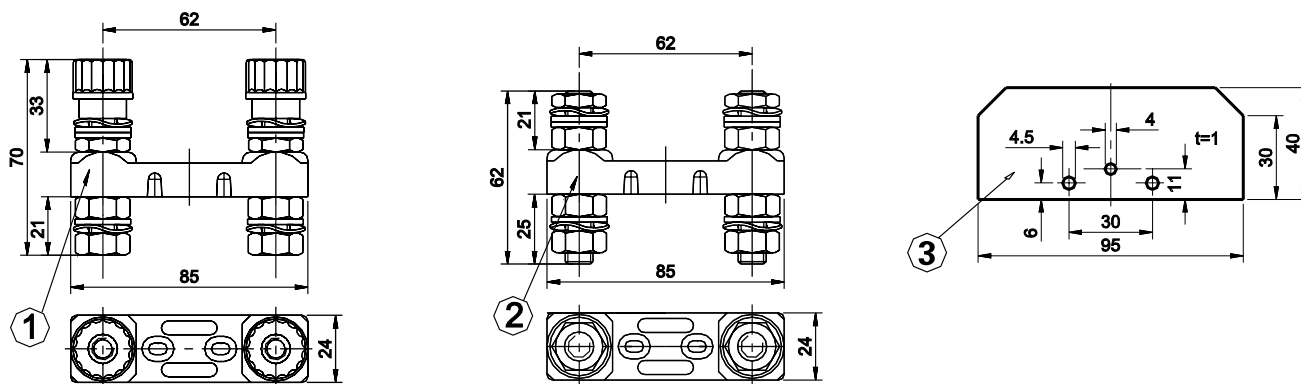

Ratings

Part Number	Description	Contact Temperature
177.5702.0001	1) Fuse base	max. 250 A
177.5741.0001	2) Fuse base	max. 250 A
192.5710.0001	3) Phase barrier	-

Corresponding fuse strips see Section "Bolt-Down Fuses."

BATTERY CLAMP FOR CF8 FUSE RATED 58V

RoHS



Specifications

Material: Brass G-Cu Zn 33 Pb
Starting Torque: 10 Nm at batterypole, 12 Nm Compact Fuse

Ordering Information

Part Number	Package Size
255.1000.0001	100
255.2000.0001	50

Description

Battery clamp for CF8 Fuse links. Both battery clamps have an integrated twisted protection for the CF8-fuse link.

Dimensions

Dimensions in mm

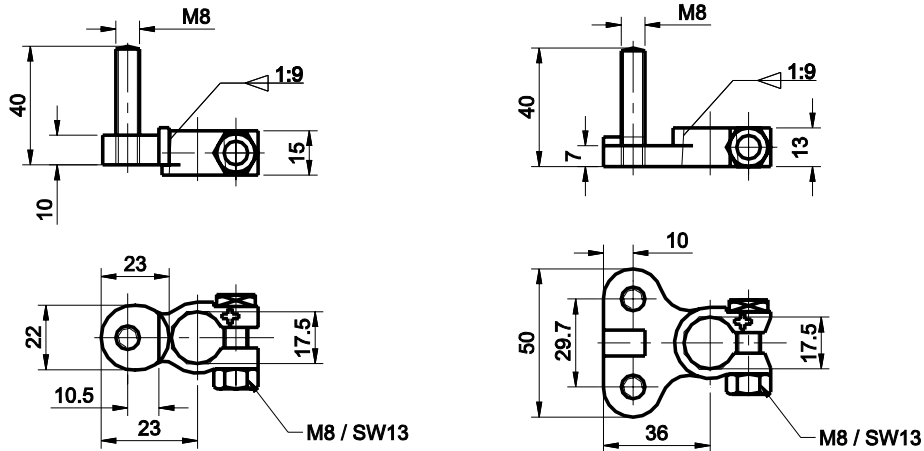

Ratings

Part Number	Description	Fuse Rating
255.1000.0001	Battery clamp 1 pole	max. 250 A (23+5°C)
255.2000.0001	Battery clamp 2 pole	max. 250 A (23+5°C)

CF8-fuses links only in conjunction with Insulating nuts 255.0808.0001, 255.0899.4001 or 255.0899.5001.
Corresponding CF8-fuse links see Section "Bolt-Down Fuses." If the ring terminal makes contact with the terminal fuse stud, the fuse is bypassed and is not protecting the circuit. Insert CF8-Fuse links only in conjunction with the insulating nut see next page.

INSULATING NUTS FOR CF8 FUSE

RoHS



Specifications

Material: Thermoplastic, Duroplastic
 Packaging Unit: Pos.1 = 250 pieces
 Pos.2 + 3 = 100 pieces

Ordering Information

Part Number	Package Size
255.0808.xxx1	250
255.0899.xxx1	100

Description

Insulating nuts for CF8 Fuse links.

Dimensions

Dimensions in mm

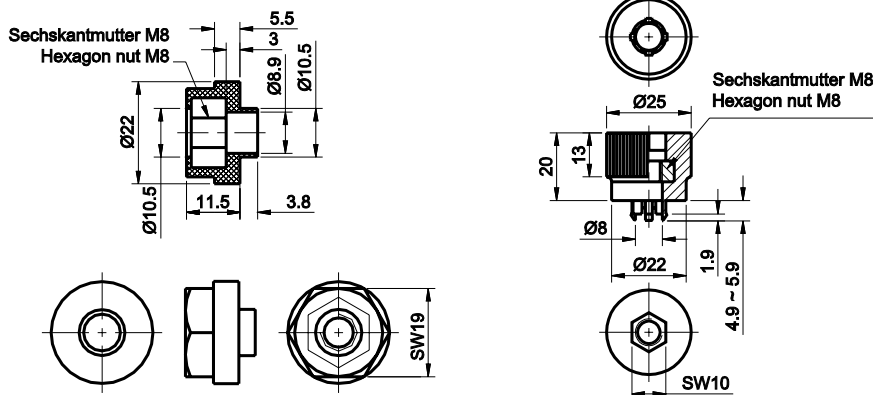

Ratings

Part Number	Description	Contact Temperature
255.0808.0001	Insulating nut (Duroplastic)	max. 300 A (23°C+-5°C)
255.0899.4001	Insulating nut with locking hook 4.9 mm (Thermoplastic) (Red)	max. 150 A (23°C+-5°C)
255.0899.5001	Insulating nut with locking hook 5.9 mm (Thermoplastic) (Black)	max. 150 A (23°C+-5°C)

Corresponding fuse links see Section "Bolt-Down Fuses."
 If the ring terminal makes contact with the terminal fuse stud, the fuse is bypassed and is not protecting the circuit.

Fuse Pullers



Pullers	169
Pullers / Tester	169
Fuse Puller - MINI[®] Fuse	170

PULLERS



Description

Allows for easy fuse removal and replacement.

Ordering Information

Part Number	Package Size
165.0020.0002	500
00970021HXNVDL	100
00970021NXVDL	5000
00970023HXN	100
00970023Z	500
00970024M	1000
00970024Z	7500
00970027LXN	50
00970027N	2000
00970053Z	1
00970999P	2000

Ratings

Part Number	Description
165.0020.000_	ATO® / MINI® / MAXI™ Style
00970021_	ATO® / MINI® Style
00970023_	ATO® / MINI® / Glass Style
00970024_	MINI® Style
00970027_	MAXI™ Style
00970053_	JCASE® Style
00970999_	ATO® Style

PULLER / TESTER



Description

Conveniently and easily tests ATO® and MINI® blade fuses either in or out of the fuse block. Indicator light on tester glows bright green when fuse is good. Fuse puller end allows for easy fuse removal and replacement. 24V maximum.

Dimensions

Dimensions in mm

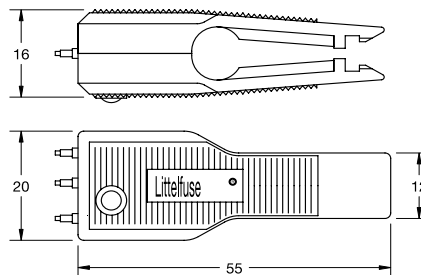

Ordering Information

Part Number	Package Size
00970019X	10

Ratings

Part Number	Description
00970019X	ATO® /MINI® Style

FUSE PULLER - MINI® FUSE



Description

This fuse puller is designed to allow for easy removal of MINI® fuses and other MINI® style components. Its narrow profile enables you to remove a fuse even when nested between two larger components (i.e. relays.) The material used provides a robust design that lasts through multiple fuse withdrawal cycles.

This puller is used primarily with the Littelfuse FLEC™ Flexible Electrical Center, but can be used with any other junction box, power distribution center or fuse holder that uses MINI® components.

Specifications

Material:

PBT

Ordering Information

Part Number
00970032Z

Specialty Products



Resistors, Diodes and Shunts	172
ATS Ceramic Fuse Rated 36V	174
Thermoplastic Fuse Rated 36V	175

SPECIALTY PRODUCTS

ATO® Diode



MINI® Diode



Specifications

Operating Temp.: -40°C to +85°C
 Resistor Value: Optional
 Power Rating: 1/4 W Max
 Body Material: Thermoplastic
 Term. Material: C.R.S. (Ni/Zn Plated)
 Term. Retention: 25 N

Part Number	Type	Current Rating	Peak Inverse Voltage	Housing Color	Part Quantity
02400103_	ATO	1 A	400 Volts	Black	Z = 1500 / LXN = 50
02400104P	MINI	1 A	400 Volts	Black	2000
02400110P	MINI	1 A	400 Volts	Black	2000
02400113P	MINI	1 A	400 Volts	Black	2000
02400115P	MINI	1 A	1000 Volts	Green	2000
02400119P	MINI	1 A	400 Volts	Black	2000
02400120P	MINI	1.5 A	400 Volts	Brown	2000

* 1 A Diode in ATO® size housing. The cathode connector is rotated 90°

ATO® Resistor



MINI® Resistor



Specifications

Resistor Value: Optional
 Body Material: Thermoplastic
 Term. Material: C.R.S. (Ni/Zn Plated)
 Term. Retention: 25 N

Operating Temp for ATO is -20°C to +85°C
 Power Rating: 1/4 W Max

Operating Temp.: -40°C to +85°C
 MINI Resistor Power Rating is up to 1/2 W

Part Number	Type	Current Rating	Wattage	Housing Color	Part Quantity
02400105Z	ATO	10K ohm	¼ Watt	White	1500
02400116P	ATO	750 ohm	¼ Watt	Yellow	2000
02400106P	MINI	620 ohm	½ Watt	Grey	2000
02400107P	MINI	121 ohm	½ Watt	Grey	2000
02400108P	MINI	5.1K ohm	¼ Watt	Blue	2000
02400111P	MINI	16.9 ohm	¼ Watt	Red	2000
02400112P	MINI	121 ohm	½ Watt	Green	2000
02400114P	MINI	240 ohm	½ Watt	Green	2000
02400118P	MINI	500 ohm	½ Watt	Grey	2000
02400121P	MINI	1500 ohm	¼ Watt	Grey	2000
02400122P	MINI	1130 ohm	¼ Watt	Grey	2000

SPECIALTY PRODUCTS

ATO® Shunt



Operating Temp.: -40°C to +125°C
 Maximum Continuous Load Rating: 35A
 Body Material: Thermoplastic (UL 94V0 Rated)
 Term. Material: Brass Tin Plated

MINI® Shunt



Operating Temp.: -40°C to +125°C
 Maximum Continuous Load Rating: 20A
 Body Material: Thermoplastic (UL 94V0 Rated)
 Term. Material: Zinc Silver Plated

JCASE® Shunt



Operating Temp.: -40°C to +125°C
 Maximum Continuous Load Rating: 50A
 Body Material: Nylon
 Term. Material: Copper

Part Number	Type	Max Continuous Load Rating	Body Material	Terminal Material	Part Number
02400094P	ATO	35 A	Thermoplastic (UL 94V0)	Brass Tin Plated	2000
0297900.WXNV	MINI	20 A	Thermoplastic (UL 94V0)	Zinc Silver Plated	3000
0495900_	JCASE	50 A	Nylon	Copper	Z=2200 pcs/X=1 pc

More shunt options available on littelfuse.com

ATS CERAMIC FUSE RATED 36V

RoHS



Specifications

Insulating Body: Out of ceramic
Melting Element: See chart below
Complies with: DIN 72581-1

Ordering Information

Part Number	Package Size
151.51xx.xx6	100
151.51xx.xx2	5000

Pre-Arcing Time-Limits

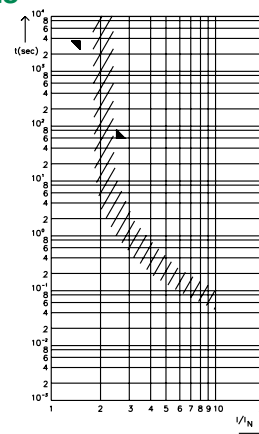

FI = 1.00 (max. operating current:
1.0 x I_{rat} at 23°C)

Description

36 VDC Torpedo-style fuse links with current rating 5A to 25A.

Dimensions

Dimensions in mm

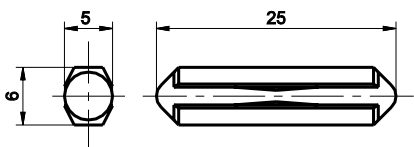

Time-Current Characteristics

% of Rating	Opening Time Min / Max (s)
150	1 h / -
250	- / 60 s

Ratings

Part Number	Current Rating	Melting Element	Housing Color	Typ. Voltage Drop	
				Standard DIN max.	Littelfuse max.
151.5155.450_	5 A	Zn, gal. SN	Yellow	100 mV	50mV
151.5112.4806	8 A	Zn	White	100 mV	50mV
151.5152.4802	8 A	Zn, gal. SN	White	100 mV	50mV
151.5162.4802	8 A	CuZn	White	100 mV	50mV
151.5173.4802	8 A	CuZn	White	100 mV	50mV
151.5182.516_	16 A	Cu	Red	100 mV	50mV
151.5182.5162	16 A	Zn, gal. SN	Red	100 mV	50mV
151.5182.525_	25 A	Cu	Blue	100 mV	50mV

Corresponding holder see Section "Fuse Holders."

THERMOPLASTIC FUSE RATED 36V

RoHS



Description

Consisting of a heat resistant body, the fuse element stretches over the exterior of the body from end to end. The body varies in color indicating the current ratings.

Specifications

Complies with: DIN 72581-1

Ordering Information

Part Number	Package Size
0214xxx.LXN	50
0214xxx.K	10000

Dimensions

Dimensions in mm

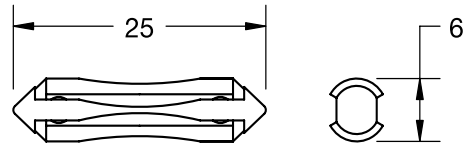

Ratings

Part Number	Current Rating	Housing Color	Typ. Voltage Drop Littelfuse max
0214005_	5A	Yellow	50mV
0214008_	8A	White	50mV
0214016_	16A	Red	50mV
0214025_	25A	Blue	50mV
0214040_	40A	Grey	50mV

Fuseology



I. Introduction

The purpose of this Fuseology section is to promote a better understanding of fuses and some of the more common application details. The fuses to be considered are current-sensitive devices which are designed as the intentional weak link in the electrical circuit. The function of a fuse is to provide discrete component or complete circuit protection by reliably melting under overcurrent conditions and thus safely interrupting the flow of current.

II. Types of Overcurrents

An overcurrent is any current which exceeds the ampere rating of wiring, equipment or devices under conditions of use. The term "overcurrent" includes both overloads and short circuits.

A. Overloads

An overload is an overcurrent which is confined to normal current paths. An overload occurs when the current exceeds the value for which the wires or equipment are rated. This can happen when too many devices are connected to the circuit, or when a device connected to the circuit malfunctions in a way that causes it to draw higher than normal current, usually in the range of one to six times normal current. Sustained overloads eventually overheat circuit components. Therefore, fuses must open circuits experiencing sustained overloads before damage occurs.

B. Short Circuits

A short circuit is current out of its normal path. It occurs when accident or malfunction creates an unintended path for the electricity to flow from the battery or alternator to ground. This shorter, more direct path to ground bypasses the resistance normally offered by the wiring and devices connected to the circuit. With virtually no resistance left to impede current flow, the voltage forces higher and higher current to flow through the wires to the point of the short. Under such a condition, the current will quickly build to such a high level that the heat generated can cause insulation to burn and equipment to be damaged unless the circuit is opened through the use of a fuse.

III. Fuse Selection Parameters

Since overcurrent protection is crucial to reliable electrical system operation and safety, fuse selection and application should be carefully considered. When selecting fuses, the following parameters should be evaluated:

A. Voltage Rating

The voltage rating, as marked on a fuse, indicates the maximum voltage of the circuit for which the fuse is designed to operate safely in the event of an overcurrent. Therefore, the fuse's voltage rating must equal or exceed the available circuit voltage where the fuse will be installed. System voltage exceeding the fuse's rated voltage may result in fuse damage. The voltage rating is 32 volts DC for the MINI®, MAXI®, ATO®, MIDI®, MEGA®, and CABLEPRO® Fuses.

B. Interrupting Rating

The interrupting rating (also known as breaking capacity or short circuit rating) is the maximum current, as stated by the manufacturer, which the fuse can safely interrupt at rated voltage. During a fault or short circuit condition, a fuse may receive an instantaneous current many times greater than its normal operating current. Safe operation requires that the fuse remain intact (no body rupture) and clear the circuit. The interrupting rating is 1000A @ 32 volts DC for the MINI®, MAXI®, ATO®, JCASE®, and MIDI® Fuses, and 2000A @ 32 volts DC for the MEGA® and CABLEPRO® Fuses.

C. Time-Current Characteristics

A fuse's time-current characteristics determine how fast it responds to different overcurrents. All fuses have inverse time-current characteristics, so opening time decreases as overcurrents increase. Time-current characteristics are presented graphically on standardized "log-log" paper. Figure 1 is a sample time-current curve for the MAXI Fuse series for fuses rated 20-60A. Current values increase from left to right, and time increases from bottom to top. The average melting time for any current can be determined from the curve. For example, from Figure 1 it can be determined that a 20A MAXI Fuse experiencing an overload of 100A will open in about 0.5 seconds. At 40A, the same 20A MAXI Fuse would open in about 9 seconds.

Time-current curves are also used to compare fuses of the same series but of different current ratings. Suppose it was desired to compare the opening times of 20A and 60A MAXI Fuses at an overload of 100A. From the curve in Figure 1, one can see that the 20A fuse opens in about 0.5 seconds at 100 amps, whereas the 60A fuse does not open until about 50 seconds.

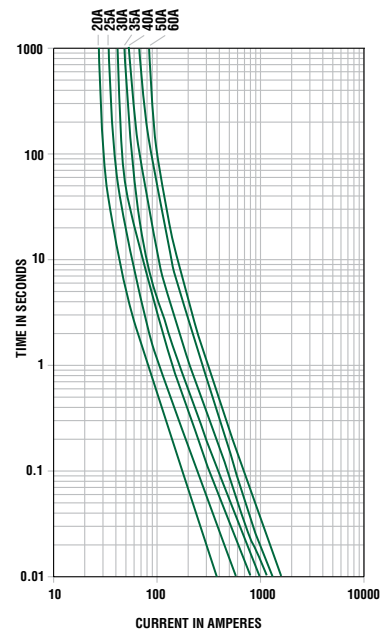

Figure 1: Average Melting-Current Curve for the MAXI Fuse Series (20-60A)

It is important to note that time-current curves give only average melting times and are presented as a design aid but are not considered as part of the fuse specifications.

The term used in fuse design that describes how rapidly a fuse responds to various overcurrents is the fuse's "characteristics." Automotive fuse characteristics are determined by the fuse's degree of time delay. Initial or start-up pulses are normal for many automotive applications and require fuses to have a time delay designed in to enable them to survive these pulses and still provide protection against prolonged overloads. Fuses such as the MINI® Fuse and ATO® Fuse have a moderate degree of time delay, whereas fuses like the MAXI® Fuse and MEGA® Fuse have a high degree of time delay which enables them to handle high inrush currents like those caused by motor start-ups. Figure 2 compares sample time-current curves of a 30A MINI Fuse to a 30A MAXI Fuse. To see that the MAXI Fuse has more time delay than the MINI Fuse, compare their opening times at an overload of 100A. Despite the fact that the fuses are the same rating, the MINI Fuse opens in about 0.1 seconds while the MAXI Fuse opens in about 2.2 seconds.

When selecting a fuse, the start-up pulse should be defined and then compared to the time-current curve for the fuse.

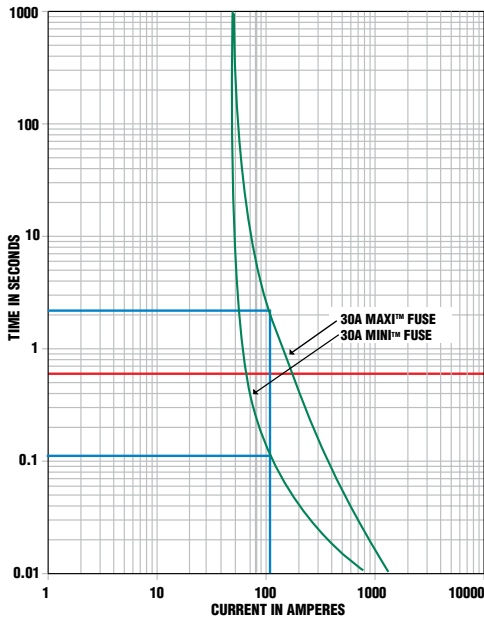

Figure 2: Average Melting-Current Curve Comparing 30A MINI Fuse to 30A MAXI Fuse

D. Current Rating

The current rating is the maximum current which the fuse can continuously carry under specified conditions.

1. Normal Operating Current

The current rating of a fuse is typically derated 25% for operation at 25°C to avoid nuisance blowing. For example, a fuse with a current rating of 10A is not

usually recommended for operation at more than 7.5A in a 25°C ambient.

2. Rerating for Ambient Temperature

The current carrying capacity tests of fuses are performed at 25°C & will be affected by changes in ambient temperature. At higher ambient temperatures, a fuse will respond faster to a given overload. Conversely, at lower ambient temperatures, a fuse will respond slower to a given overload. In addition, the temperature of the fuse increases as the normal operating current approaches or exceeds the rating of the fuse.

A MINI Fuse operating at 25°C and 110% of rated current has a minimum life of 100 hours. However, if that same fuse were operated at a very high ambient temperature, rerating would be necessary. Figure 3 is a sample temperature rerating curve for the MINI Fuse. The following example shows how to use such a curve.

Suppose there is a normal operating current of 15 amperes in a particular circuit, and the ambient temperature will be 105°C instead of 25°C. Which MINI Fuse rating should be used? From Figure 3, the percent of rated current to be used at an ambient temperature of 105°C is 88%, so:

$$\begin{aligned} \text{Ideal fuse rating} &= \frac{\text{Normal operating current}}{\text{Temp rerating factor} \times 0.75} \\ &= \frac{15A}{0.88 \times 0.75} \\ &= 22.73A \end{aligned}$$

Therefore, a 25A or larger MINI Fuse should be used.

E. Transient Overcurrent Considerations

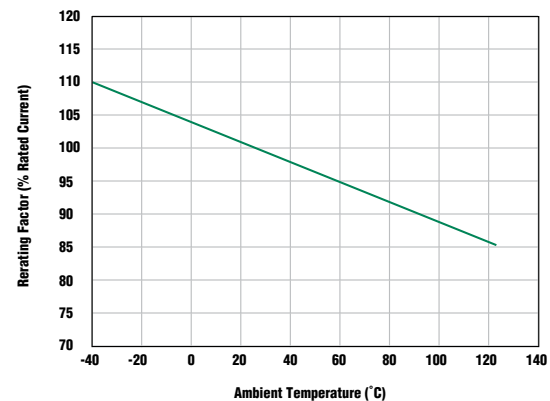

Figure 3: MINI Auto Fuse 297 Series Temperature Rerating Curve

Transient pulses of inrush current are commonplace in vehicle electrical systems. The transient overcurrent pulses affect the life of automotive fuses.

1. I²t

I²t is an expression of the available thermal energy resulting from current flow. With regard to fuses, the term is usually expressed as melting, arcing, and total

clearing I^2t . The units for I^2t are expressed in ampere-squared-seconds [A^2s].

Melting I^2t : the thermal energy required to melt a specific fuse element.

Arcing I^2t : the thermal energy passed by a fuse during the arcing time. The magnitude of arcing I^2t is a function of the available voltage and stored energy in the circuit.

Total Clearing I^2t : the thermal energy through the fuse from overcurrent inception until current is completely interrupted. Total clearing $I^2t = (\text{melting } I^2t) + (\text{arcing } I^2t)$.

I^2t has two important applications to fuse selection. The first is pulse cycle withstand capability and the second is selective coordination.

2. Pulse Cycle Withstand Capability

Electrical pulses produce thermal cycling and possible mechanical fatigue that could affect the life of the fuse.

For this reason, it is important to know the pulse cycle withstand capability of the fuse, which is defined as the number of pulses of a given I^2t value that can be withstood by the fuse without opening, assuming that there is sufficient cool down time between pulses.

Figure 4 shows how I^2t of the pulse can be calculated from the graph of the pulse current as a function of time.

WAVESHAPE FUNCTION AND VALUE

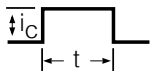

$i = k$
 $I^2t = i_c^2t$

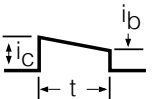

$i = i_c \pm kt$
 $I^2t = (1/3)(i_c^2 + i_b i_c + i_b^2)t$

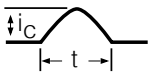

$i = i_c \sin t$
 $I^2t = (1/2)i_c^2t$

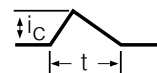

$i = \pm kt$
 $I^2t = (1/5)i_c^2t$

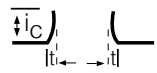

$i = kt^2$
 $I^2t = (1/5)i_c^2t$



$i = i_c e^{-t/t}$
 $I^2t = (1/2)i_c^2t$

Figure 4: Evaluating the I^2t of a Variety of Current Wave Shapes

Figure 5 is a graph of the pulse cycle withstand capability of blade fuses. Because electrical pulse conditions can vary considerably from one application to another, application testing is recommended to establish the ability of the fuse design to withstand the pulse condition.

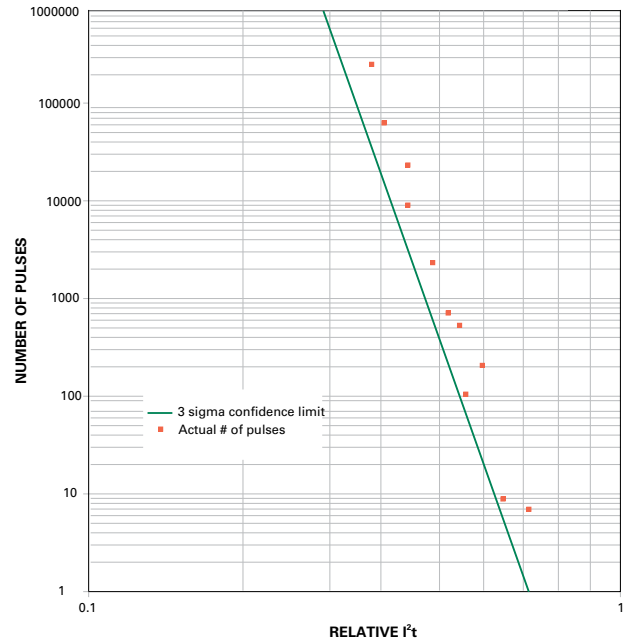

Figure 5: Pulse Cycle Withstand Capability for Blade Fuses

3. Selective Coordination

In a selectively coordinated system, only the fuse immediately on the line side of an overcurrent opens. Upstream fuses remain closed and undamaged. All other equipment remains in service, which simplifies locating overloaded equipment or short circuits. In Figure 6, if a short circuit arises behind fuse #1, fuse #1 should open and fuse #2 should stay closed and undamaged. The condition necessary to assure this result is that the minimum melting I^2t of the supply side fuse (fuse #2) must be greater than the total clearing I^2t of the load side fuse (fuse #1). This condition results in the load side fuse opening before the supply side fuse begins to melt. Minimum melting and total clearing I^2t data are given in this catalog.

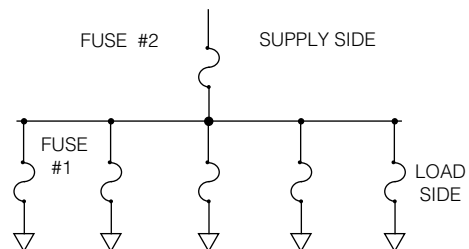

Figure 6: Selective Coordination for Fuses in Series

IV. Voltage Drop Across Terminals

A fuse is only as good as the system in which it is used. One aspect of the electrical system that has considerable effects on the performance of the fuse is the quality of the connection between the fuse and the cable it protects. High voltage drop across the fuse/terminal interface creates additional thermal loading, which in turn causes shifts in the time-current characteristics of the fuse. Table 1 below gives the maximum recommended voltage drop per terminal for automotive fuses. Figure 7 indicates the measurement locations used to determine the voltage drop across the terminal. The voltage drop across the left terminal would be $V_{2,4}$ and the voltage drop across the right terminal would be $V_{1,3}$.

Type	Maximum Recommended Voltage Drop Per Terminal [MV]
ATO® FUSE	30
MINI® FUSE	30
MAXI® FUSE	30
MEGA® FUSE	15

Table 1: Maximum Recommended Voltage Drop per Terminal

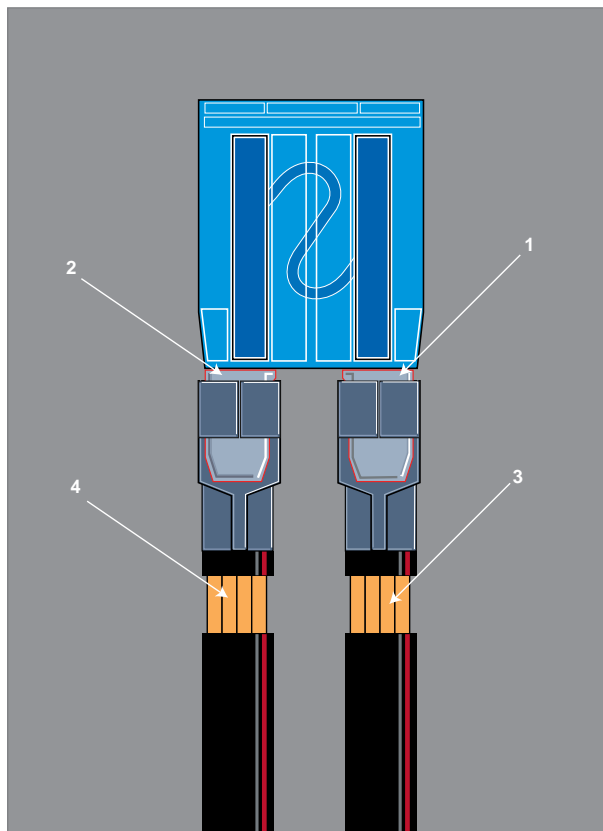

Figure 7: Measurement Locations along the Fuse/Terminal/Cable System Used to Determine the Voltage Drop across the Terminal

V. Diffusion

Diffusion Pill Technology is a mixing of molecules, atoms or crystals in the solid, liquid or gaseous state. Diffusion Pill Technology is often used in the design of fuses for automotive, electronic and industrial fuse applications.

“M-effect” is the method of diffusing one metal into another to form a new alloy with a lower melting point. Littelfuse uses the “M-effect” to produce three very desirable characteristics in fuse designs: lower melting temperature, time delay, and lower voltage drop.

By affixing a diffusion pill tin to the element, the melting temperature is decreased. This decrease in melting temperature reduces the fuse rating. In order to reestablish its original rating the fuse elements’ cross section needs to increase. An increase in cross section increases the blow time at higher overload condition. A higher degree of time delay enables a fuse to withstand higher current inrush pulses. This increase in cross section reduces the overall fuse resistance and voltage drop.

VI. Match Wire Gauge to Fuse

In order to protect wiring under all overload and short circuit conditions, it is necessary to standardize the fuse and wire selection process.

Fuses have controlled opening characteristics, and each wire gauge has its respective current carrying capacity. Fuses need to be selected to always protect the wire insulation from damage.

In the selection of wire gauge at various ambient temperatures, it is important to consider the worst case or highest ambient temperature for the application. Wires derate to a much higher degree than fuses, because wire insulation temperature capability is affected much more severely.

Maximum Recommended Continuous Current

Wire Size		Max Continuous Current (A)				
		At 25°C		At 80°C		At 105°C
mm ²	Gage No.	GXL (1)	GPT (2)	GXL (1)	GPT (2)	GXL (1)
0.3		15	10	11	4	9
0.5	20	21	15	16	6	13
0.75		27	21	20	7	17
0.8	18	31	22	23	7	19
1	16	33	23	25	9	20
1.5		43	30	33	12	27
2	14	50	36	37	14	32
2.5		60	42	45	15	38
3	12	68	47	51	18	42
4		80	56	61	22	50
5	10	90	65	68	23	58
6		103	73	78	28	64
8	8	125	87	96	30	79
10		146	103	111	40	90
13	6	170	120	129	47	105
19	4	221	156	166	61	137

(1) = General purpose cross link polyethylene insulation wire with a maximum insulation temperature of 155°C.

(2) = General purpose thermoplastic insulation wire with a maximum insulation temperature of 90°C.



Expertise Applied | Answers Delivered

English | Find a Distributor

Search All | Search by Keyword | Search by Part Number

PRODUCTS

INDUSTRIES

SERVICES

TECHNICAL RESOURCES

Company | Contact Us

Home | Products | Fuses | Passenger Car and Commercial Vehicle

Passenger Car and Commercial Vehicle

WWW.LITTELFUSE.COM

To assist you with your design and selection processes, Littelfuse also offers:

Comprehensive Online Product Specs on Littelfuse.com—Featuring easy-to-use navigation, search and selection tools, as well as additional product details. You can rely on Littelfuse.com for instant answers and continuously up-to-date information.

Printed Product Catalogs—For offline and off-the-shelf convenience, our printed product catalogs include data sheets, selection tables and tutorials covering all of our core technologies. Contact your Littelfuse product representative or visit www.littelfuse.com/about-us/product-catalogs to check availability.

Circuit Protection Design Guides—Our application-design center website, www.littelfuse.com/technical-resources/application-designs offers a wealth of circuit protection guidance to help you select and apply the best circuit protection solution for your application.

As the world's #1 brand in circuit protection Littelfuse offers the broadest and deepest portfolio of circuit protection products and a global network of technical support, backed by more than 85 years of application design expertise. For all of your circuit protection needs visit our Technical Resources center at www.littelfuse.com/technical-resources

- **Application Notes**
- **Application Testing**
- **SPICE Models**
- **Local Technical Support**
- **Reference Designs**
- **Product Samples**
- **Technical Articles**
- **Certification Documents**
- **Data Sheets**



WWW.LITTELFUSE.COM

Littelfuse is the world leader in circuit protection. We offer an extensive selection of circuit protection technologies for Automotive applications. Littelfuse circuit protection expert staff can assist you in designing circuit protection for your most demanding applications. Solutions for over-current applications as well as over-voltage applications are available from Littelfuse.

Low Current Distribution (LCD) MICRO2, MICRO3, LP MINI, MINI, ATOF, MAXI, MCASE, LP JCASE, JCASE

High Current Distribution (HCD) MIDI, BF1, MEGA, CF

Advanced Power Systems High-voltage and customized fusing solutions

Battery Cable Protection (BCP) CABLE PRO and BF-Inline products for mounting directly inline as part of a high-power cable assembly

Fuse, Relay and Specialty Modules Modular system for constructing custom fuse and relay boxes for low volume applications

Power Distribution FLEC Customizable pre-tooled junction boxes

Accessories For assembly and mounting, shunts, fuse pullers, fuse holders terminals, terminal locks etc.

For more information, please contact your authorized Littelfuse product representative or visit our website at www.littelfuse.com