

Material Handling, Storage & Transport Products

Store, Organize & Transport

*“Canada’s Largest Single Source for
Material Handling & Transport Products”*

 **AKRO-MILS**[®]
CANADA

www.akro-milscanada.com

A Myers Industries Company

About Akro-Mils®

Akro-Mils Mission

Akro-Mils Canada is committed to providing innovative storage and material handling products of uncompromising quality at a fair price. We support this commitment with professional representation and consistent, superior service to meet the needs of our customers. If you are ever less than 100% satisfied with the quality of any Akro-Mils product, or if you have any suggestions on how we can improve our service, please give me a call –

*Jim Morrison
General Manager,
Akro-Mils Canada*

We accept



Certified to
ISO 9001:2000

The Akro-Mils Advantage

Akro-Mils Canada products save time and money by helping to increase material handling and distribution efficiency. Our broad range of storage, organization, and transport products helps to speed cycle times, maintain accurate inventories, optimize storage space, and improve parts protection. For quality products backed by more than 50 years of reliable delivery and responsive customer service, look to the Akro-Mils Canada advantage.

All New Products ... All the Time

Akro-Mils Canada introduces more new products to the Canadian market on a regular basis than does any other comparable manufacturer. We stay ahead of the pack by being INNOVATIVE. We offer fast service, competitive pricing, and we are extremely responsive to our customers' needs. This catalogue details our standard product lines. Please feel free to contact us for special sizes and configurations.

New! Powder Coating

Akro-Mils Canada's new powder coating capabilities provide not only a high-quality, durable finish to our standard and custom transport products, but also a resource for custom powder coating your own products in large or short volume runs. Powder coating increases the value of a product by improving the quality, appearance, and durability in a cost-effective way.

Quality Systems Produce Top-Quality Products

Each of Akro-Mils Canada's suppliers are in compliance with quality process standards and effective quality management systems in the design, production, and distribution of plastic storage products. To you, our valued customer, this certification ensures you will continue to receive consistent, high-quality products from Akro-Mils Canada. Products manufactured in our Akron, Ohio; Wadsworth, Ohio; Sandusky, Ohio; Milford, Ohio; Ontario, California; and our Nanterre Cedex France facilities are within the ISO 9001:2000 certified system. We are working to certify our other facilities in the near future.

Canada-wide Network of Logistics Professionals

Akro-Mils Canada maintains a nationwide network of sales consultants, dealers, and distributors. We keep them updated as to new developments and products, so they may be positioned to help you. We support them fully and do not sell direct to end-users.

Ready to Ship to Meet Your Needs

You may draw on full inventories in our warehouses for fast shipping. Our multiple manufacturing locations assure a reliable supply of stock. Our dealers rate our responsiveness and customer service among the best, and our after-sales support is second to none. End-users, please consult your Akro-Mils Canada distributor for terms and conditions of sale.

Efficient and Knowledgeable Customer Service

Our team of customer service specialists is prepared to answer all of your questions. Call us to learn more about our products and services, or contact your local dealer or distributor. At Akro-Mils Canada, your satisfaction is our priority – every time!

Table of Contents

Storage Bins		Small Parts Storage		
	AkroBins®	6	Steel Storage Cabinets	46
	Louvered Hanging Systems	7	Mobile Steel Cabinet Rack	46
	Rail Hanging Systems	8	Storage-Go-Round	46
New!	Cabinet Systems	9	Plastic Storage Cabinets	47
New!	Super-Size AkroBins® & Dollies	10	Portable Organizers	47
New!	Stack-N-Store Bins	10	Storage Cases	48
	Shelf Bins	11	New! ProBox™ Tool Boxes	48
New!	Shelving Systems	12	New! Tool Rack	48
New!	Pick Rack Systems	13	New! Wrench Holder	48
	Economy Bins	14	Tilt & Locks	49
	1800 Series AkroBins®	14	Akro/Logic™ Organizers	49
	ESD AkroBins®	15	Roto-Shelf	49
	ESD Hanging System	15	Carts & Transport Systems	
	ESD Shelf Bins	15	ProCart™	52-53
	ESD Grids	15	File Manager Cart	53
Totes & Containers			Shelf Cart	53
	Nest & Stack Totes	18	VERSA/Deck™	54-55
	Bi-Color Stack & Nest Totes	19	Platform Trucks – Wood Deck	56-58
	KeepBoxes™	19	Platform Trucks – Work Height	59
New!	Attached Lid Containers	20-22	Skids – Semi-Live & Dead	59
	Detached Lid Containers	22	Platform Trucks – Steel	60
	Akro-Grids	23	Shelf & Multi-Shelf Carts	61
	Straight Wall Containers	24-25	Compact Tote Truck	61
	Heavy-Duty Boxes, Totes & Trays	26-27	Bin Carts	61
	Tote Caddy	27	Portable Tables & Carts	62
	Cross-Stack Akro-Tubs	28	High-End Narrow Aisle Truck	63
	Agricultural Containers	29	Tray Service Cart	63
	Specialty Containers	29	Box Trucks	63
	Food Processing Containers	30-31	Heavy-Duty Work Benches	64
	Bulk Boxes	32-33	Mobile Work Tables	65
	Pallets	34-35	Trucks & Dollies	
Recycling & Waste Transport Systems			Wood Dollies	68-69
	Recycling Containers	38	Polyethylene Dollies	70
	MegaKart®	39	Steel Dollies	70
	BossKart®	39	Aluminum Dollies	70
	Versa-Kart®	39	Hand Trucks	71
	Akro-Cart	40	Specialty Hand Trucks	72-73
	Whisper Series	40	Drum Handling Equipment	74-75
	Tilt-Truck	41	Reference	
	Akro-Lift	41	Materials Definitions & Benefits	76
	AkroClean™ Janitor Cart	42	Caster & Wheel Definitions	76
	Compact Cleaning Cart	43	Model Number Index	77-79



Storage Bins



6

AkroBins®

Pick, sort, store, and label small parts with versatile AkroBins.

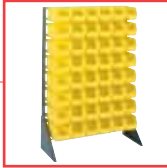

7-8

Hanging Systems

Hang AkroBins for convenient parts storage and retrieval.



9

Cabinet Systems

Protect parts and products from dust, damage, and theft.



10

Super-size AkroBins®

Extra-large, deep bins store and organize large, bulky items.



10

Stak-N-Store

Stackable containers with wide openings for bulky items.

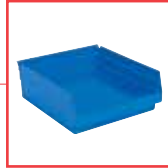

11

Shelf Bins

A colorful, durable replacement for flimsy, corrugated bins.



12

Shelving Systems

Creates an efficient storage system with shelf bins or Stak-N-Store bins.

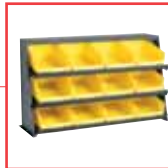

13

Pick Rack Systems

Improve workspace organization and efficiency.



14

Economy Bins

General purpose storage bins stack on shelves or nest for compact storage.



14

1800 Series AkroBins®

Extra-deep bins hold large, heavy, or bulky items.



15

ESD Containers

Safely store and transport sensitive electronic components.

Storage Bins

AkroBins®



- Control inventories, shorten assembly times, and minimize parts handling.
- Heavy-duty bins securely stack atop each other, sit on shelving, and hang from Akro-Mils racks, panels, rails, and carts.
- Molded of high-density polypropylene, AkroBins are unaffected by weak acids and alkalis.
- Sturdy, one-piece construction is water, rust, and corrosion-proof.
- Guaranteed not to crack or break under normal load conditions as stated in our 1-year limited warranty.
- Autoclavable up to 250° F.
- Available in 12 sizes and 4 colors: Red, Yellow, Blue, and Stone.

Anti-slide stop prevents stacked bins from shifting forward

Full-width hanger lip supports bin on hanging system

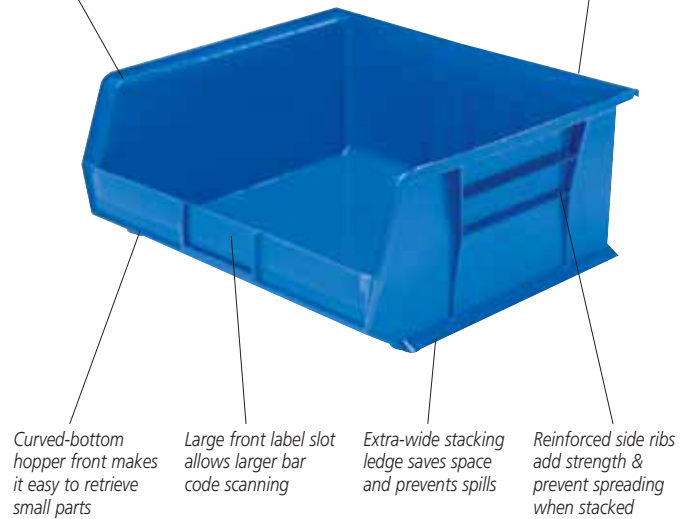

Curved-bottom hopper front makes it easy to retrieve small parts

Large front label slot allows larger bar code scanning

Extra-wide stacking edge saves space and prevents spills

Reinforced side ribs add strength & prevent spreading when stacked

Buy Original AkroBins®

When compared to the competition, AkroBins:

- Support more weight when stacked.
- Handle more abuse.
- Hold more weight without cracking.

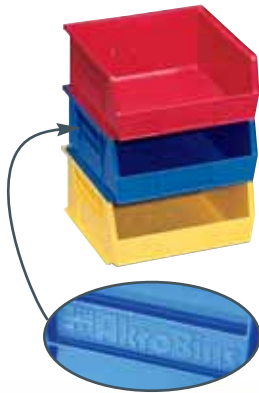

Look for our name on the side

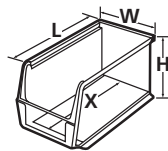

30270



30235

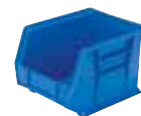

30239



30230



30210

AkroBins

Model No.	Outside Dimensions						Inside Dimensions								Bin Load Capacity On Rack**	Ctn. Qty.
	Inches			mm			Inches				mm					
	L	W	H	L	W	H	L	W	H	X	L	W	H	X		
30210	5 ³ / ₈	4 ¹ / ₈	3	137	105	76	4 ³ / ₄	3 ⁷ / ₁₆	2 ¹ / ₁₆	4	120	87	71	102	10 lbs.	24
30220	7 ³ / ₈	4 ¹ / ₈	3	187	105	76	6 ³ / ₄	3 ⁷ / ₁₆	2 ¹ / ₁₆	6	171	87	71	152	10 lbs.	24
30224	10 ⁷ / ₈	4 ¹ / ₈	4	276	105	102	10 ¹ / ₄	3 ³ / ₁₆	3 ³ / ₄	9	260	87	95	229	30 lbs.	12
30230	10 ⁷ / ₈	5 ¹ / ₂	5	276	140	127	10 ¹ / ₄	4 ³ / ₈	4 ³ / ₄	9	260	111	121	229	30 lbs.	12
30234	14 ³ / ₄	5 ¹ / ₂	5	375	140	127	14 ¹ / ₁₆	4 ³ / ₈	4 ³ / ₄	12 ¹³ / ₁₆	357	111	121	325	50 lbs.	12
30235	10 ⁷ / ₈	11	5	276	279	127	10 ¹ / ₄	10	4 ³ / ₄	9	260	254	121	229	50 lbs.	6
30239	10 ³ / ₄	8 ¹ / ₄	7	273	210	178	10	6 ⁹ / ₁₆	6 ³ / ₄	8	254	167	171	203	50 lbs.	6
30240	14 ³ / ₄	8 ¹ / ₄	7	375	210	178	14	6 ⁹ / ₁₆	6 ³ / ₄	12	356	167	171	305	60 lbs.	12
30250	14 ³ / ₄	16 ¹ / ₂	7	375	419	178	14	14 ³ / ₄	6 ³ / ₄	12	356	375	171	305	75 lbs.	6
30255	10 ⁷ / ₈	16 ¹ / ₂	5	276	419	127	9 ³ / ₄	15	4 ³ / ₄	8 ¹ / ₂	248	381	121	216	60 lbs.	6
30265*	18	8 ¹ / ₄	9	457	210	229	17 ¹ / ₈	6 ³ / ₄	8 ¹ / ₄	14 ¹ / ₂	435	171	210	368	N/A	6
30270*	18	16 ¹ / ₂	11	457	419	279	17 ¹ / ₈	14 ³ / ₄	10 ¹ / ₄	13 ³ / ₄	435	375	260	349	N/A	3

One color per carton: Specify Red, Blue, Yellow, or Stone.

*Note 30265 and 30270 are not designed for use with hanging systems.

** CAUTION: When using bins with hanging systems, do not exceed the weight capacity for the rack which may be less than the total sum of bin capacities.

Accessories:

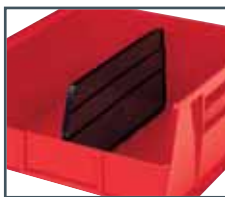

Dividers

Lengthwise dividers keep items separated in the bin.



Bin Lids*

"See-through" crystal styrene lids keep contents dust-free and protected.

Dividers

Model No.	Fits AkroBins	Pkg. Qty.
40210	30210 (1)	6
40220	30220 (1)	6
40230	30230 (1), 30235 (3)	6
40239	30239 (1)	6
40245	30240 (1), 30250 (1)	6
40265	30265 (1)	6
40270	30270 (3)	6

(Max. # of dividers)

*30224, 30255, 30234 no dividers available.

Bin Lids

Model No.	Fits AkroBins	Ctn. Qty.
30211	30210	24
30221	30220	24
30231	30230	12
30236	30235	6

*Assembly required – hinge pins included.

New Super-Size AkroBins on page 10

Louvered Hanging Systems



- Take back valuable floor space – maximize parts storage and handling efficiency.
- Louvered Panels used with AkroBins® offer the ultimate in storage flexibility.*
- Secure stationary racks to the wall or floor and wall-mountable panels to a solid structure.
- Six different models are available to accommodate up to 288 AkroBins.
- Easy, one-person assembly.

*AkroBins sold separately, see page 6.

Formed from 16-gauge cold-rolled steel for strength and durability

Attractive durable powder coated finish stands up to heavy-duty use

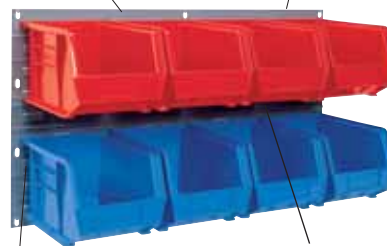

Louvers securely support AkroBins

Horizontal ribs provide added strength

30653 Louvered Floor Rack shown with 30239 AkroBins.



Develop a customized storage system by grouping any of our Louvered Panels.



30626
Double-Sided Snap Fastener Louvered Floor Rack
(Snap fasteners greatly reduce rack assembly time.)
36" L x 20" W x 60" H
914 x 508 x 1524 mm.
700 lb. capacity.



30653
Louvered Floor Rack
35³/₄" L x 32" W x 75¹/₈" H
908 x 813 x 1908 mm.
2000 lb. capacity.



30618
Louvered Panel
18" L x 19" H
457 x 483 mm.
160 lb. capacity.



30636
Louvered Panel
35³/₄" L x 19" H
908 x 483 mm.
160 lb. capacity.

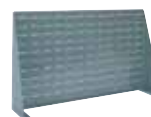

98636
Bench Rack
36" L x 8" W x 21" H
914 x 203 x 533 mm.
120 lb. capacity.



98600
Bench Rack
27³/₄" L x 8" W x 21" H
705 x 203 x 533 mm.
120 lb. capacity.

Ordering Information:

Louvered Panels And Bench Racks

Use this chart to determine the quantity of same-size AkroBins required to fill each panel.

Model No.	Description	Ctn. Qty.	AkroBins Model No. (Bin Wt. Capacity)									
			30210 (10 lbs.)	30220 (10 lbs.)	30224 (30 lbs.)	30230 (30 lbs.)	30234 (50 lbs.)	30235 (50 lbs.)	30239 (50 lbs.)	30240 (60 lbs.)	30250 (75 lbs.)	30255 (60 lbs.)
30618	18" x 19" Louvered Panel	4	16	16	12	9	9	-	-	-	-	3
30636	35 ³ / ₄ " x 19" Louvered Panel	4	32	32	24	18	18	9	8	8	4	6
	35 ³ / ₄ " x 37" (2 Panels)		72	72	36	36	36	18	16	16	8	12
	35 ³ / ₄ " x 55" (3 Panels)		104	104	54	54	54	27	28	28	14	18
	35 ³ / ₄ " x 73" (4 Panels)		144	144	72	72	72	36	36	36	18	24
98600	27 ³ / ₄ " Bench Rack	1	30	30	18	12	12	6	6	6	-	-
98636	36" Bench Rack	1	40	40	24	18	18	9	8	8	4	6

Louvered Floor Racks

Use this chart to determine the quantity of same-size AkroBins required to fill each floor rack.

Model No.	Description	Dimensions Inches			Dimensions mm			AkroBins Model Number (Bin Wt. Capacity)									
		L	W	H	L	W	H	30210 (10 lbs.)	30220 (10 lbs.)	30224 (30 lbs.)	30230 (30 lbs.)	30234 (50 lbs.)	30235 (50 lbs.)	30239 (50 lbs.)	30240 (60 lbs.)	30250 (75 lbs.)	30255 (60 lbs.)
30626	Double-Sided Snap Fastener Louvered Rack	36	20	60	914	508	1524	192	192	144	108	108	54	48	48	24	36
30653	Louvered Floor Rack	35 ³ / ₄	32	75 ¹ / ₈	908	813	1908	288	288	192	144	144	72	72	72	36	48

Rail Hanging Systems



- Rail systems offer an economical storage solution to get the most from your AkroBins.
- Single and double rail units provide more flexibility in bin placement and hold multiple sizes of AkroBins.*
- Mobile kit available to mobilize two-sided racks.
- Steel rail is ideal for work stations.

*AkroBins sold separately, see page 6.

Rails securely support AkroBins

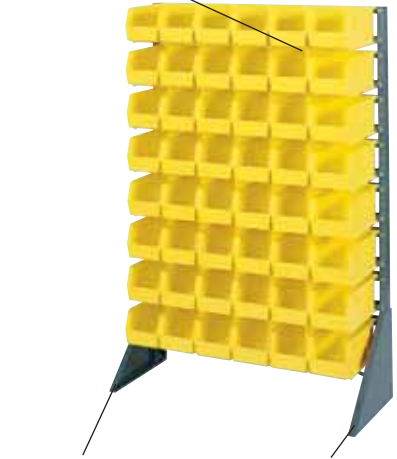

Heavy-duty steel for strength and durability

Attractive, durable powder coated finish stands up to heavy-duty use

Bench racks, wall-mount, and single- or double-sided models are available to create a complete storage system.



30006
1-Sided, 12 Rail
250 lb. capacity.



30008
1-Sided, 16 Rail
250 lb. capacity.



30012
2-Sided Rack, 12 Rail
500 lb. capacity.



30016
2-Sided Rack, 16 Rail
500 lb. capacity.



30812
Bin Cart w/ Casters
14-gauge steel work top. 250 lb. capacity.

Ordering Information:

Rail Racks & Bin Cart

Use this chart to determine the quantity of same-size AkroBins required to fill each rack and cart.

Model No.	Description	Ctn. Qty.	Dimensions				AkroBins Model Number (Bin Wt. Capacity)											
			Inches		mm		30210 (10 lbs.)	30220 (10 lbs.)	30224 (30 lbs.)	30230 (30 lbs.)	30234 (50 lbs.)	30235 (50 lbs.)	30239 (50 lbs.)	30240 (60 lbs.)	30250 (75 lbs.)	30255 (60 lbs.)		
30006	Rack, 1-Sided, 12 Rail	2	36	14 7/8	53	914	359	1346	96	96	-	-	-	-	24	24	12	-
30008	Rack, 1-Sided, 16 Rail	3	36	14 7/8	53	914	359	1346	-	-	48	48	48	24	-	-	-	16
30012	Rack, 2-Sided, 12 Rail	2	36	20	53	914	508	1346	192	192	-	-	-	-	48	48	24	-
30016	Rack, 2-Sided, 16 Rail	3	36	20	53	914	508	1346	-	-	96	96	96	48	-	-	-	32
30812	Bin Cart	2	38 1/2	24	36 1/2	978	610	927	96	96	64	48	48	24	24	24	12	16



30812 Bin Cart shown with 30230 AkroBins.



Two-Sided Racks can be mobilized with the mobile kit.

Mobile Kit – Casters & Handle

Model No.	Ctn. Qty.	Fits Hanging System No.
30424	1	30012, 30016

30148

Steel Rail

Wall-mountable unit accepts 6 sizes of AkroBins. 110 lb. capacity.



Steel Rail

Use this chart to determine the quantity of same-size AkroBins required to fill the steel rail.

Model No.	Ctn. Qty.	Dimensions				AkroBins Model Number (Bin Wt. Capacity)					
		Inches		mm		30210 (10 lbs.)	30220 (10 lbs.)	30224 (30 lbs.)	30230 (30 lbs.)	30234 (50 lbs.)	30255 (60 lbs.)
30148	1	48	3	1219	76	11	11	11	8	6	3

Cabinet Systems



AkroBin Cabinet
Louvered panels on back wall and doors hold up to 138 bins



AkroBin Cabinet with 3 Shelves
Louvered panels and 3 full (24") shelves hold up to 102 bins

- Perfect for protecting parts and products from dust, damage, and theft.
- Delivered fully assembled and ready to use.
- Cabinets feature louvered panels on doors and/or back walls.
- Choose from solid, quick-view, or secure-view (metal mesh) doors.
- All cabinets lock and come with two keys.
- Available with or without yellow AkroBin® packages to customize cabinets for your unique storage requirements.
- All cabinets are 16-gauge steel; Quick-View cabinet is 20-gauge steel.

AkroBin Cabinet 36"W x 24"D x 78"H

SKU Number	Description	Bin Model No.	Bin Dimensions L x W x H	Qty. of Bins
AC3624	Cabinet w/ Louvered Panels on Back and Doors, no Bins	-	-	-
AC3624Y	Cabinet w/ Louvered Panels on Back and Doors with Bins	30210	5-3/8" x 4-1/8" x 3"	48
		30220	7-3/8" x 4-1/8" x 3"	48
		30230	10-7/8" x 5-1/2" x 5"	24
		30240	14-3/4" x 8-1/4" x 7"	12
		30250	14-3/4" x 16-1/2" x 7"	6



AkroBin Cabinet with Flush Doors
Louvered panel on back wall holds up to 42 bins



Shelf Bin Pick Rack Cabinet

AkroBin Cabinet w/ 3 Shelves 36"W x 24"D x 78"H

SKU Number	Description	Bin Model No.	Bin Dimensions L x W x H	Qty. of Bins
AC36243AS	Cabinet w/ 3 Shelves, and Louvered Panels on Back Wall and Doors, no Bins	-	-	-
AC3624Y3AS	Cabinet w/ 3 Shelves, and Louvered Panels on Back Wall and Doors with Bins	30210	5-3/8" x 4-1/8" x 3"	48
		30220	7-3/8" x 4-1/8" x 3"	48
		30250	14-3/4" x 16-1/2" x 7"	6

AkroBin Cabinet w/ Flush Doors 36"W x 18"D x 78"H

SKU Number	Description	Bin Model No.	Bin Dimensions L x W x H	Qty. of Bins
AC3618	Cabinet w/ Louvered Panels on Back Wall, no Bins	-	-	-
AC3618Y	Cabinet w/ Louvered Panels on Back Wall with Bins	30230	10-7/8" x 5-1/2" x 5"	24
		30240	14-3/4" x 8-1/4" x 7"	12
		30250	14-3/4" x 16-1/2" x 7"	6

Shelf Bin Pick Rack Cabinet 36"W x 18"D x 78"H

SKU Number	Description	Bin Model No.	Bin Dimensions L x W x H	Qty. of Bins
APRC	Cabinet w/ 9 shelves (8 slanted), no Bins	-	-	-
APRC120Y	Cabinet w/ 9 shelves (8 slanted) with Bins	30120	11-5/8" x 4-1/8" x 4"	72

Quick-View Security Bin Cabinet 36"W x 18"D x 78"H

SKU Number	Description	Bin Model No.	Bin Dimensions L x W x H	Qty. of Bins
AC3618QV	Cabinet w/ Quick View Doors, Louvered Back, no Bins	-	-	-
AC3618QV240	Cabinet w/ Quick View Doors, Louvered Back with Bins	30240	14-3/4" x 8-1/4" x 7"	36
AC3618QV250	Cabinet w/ Quick View Doors, Louvered Back with Bins	30250	14-3/4" x 16-1/2" x 7"	18

Secure-View Security Bin Cabinet 36"W x 18"D x 78"H

SKU Number	Description	Bin Model No.	Bin Dimensions L x W x H	Qty. of Bins
AC3618SV	Cabinet w/ Secure View Mesh Doors, Louvered Back, no Bins	-	-	-
AC3618SV240	Cabinet w/ Secure View Mesh Doors, Louvered Back with Bins	30240	14-3/4" x 8-1/4" x 7"	36
AC3618SV250	Cabinet w/ Secure View Mesh Doors, Louvered Back with Bins	30250	14-3/4" x 16-1/2" x 7"	18



Quick-View Security Bin Cabinet
Lexan™ door panels; louvered back wall panel holds up to 36 bins



Secure-View Security Bin Cabinet
Steel mesh door panels; louvered back wall panel holds up to 36 bins

Super-Size AkroBins & Dollies



Available in 5 sizes and 3 colors: Red, Yellow, and Blue.



30280



30281



30282



30283



30290

- Control inventories, shorten assembly times, and minimize parts handling.
- Heavy-duty bins securely stack atop each other, or sit on shelving.
- Molded of high-density polypropylene, AkroBins are unaffected by weak acids and alkalis.
- Sturdy, one-piece construction is water, rust, and corrosion-proof.
- Guaranteed not to crack or break under normal load conditions as stated in our 1-year limited warranty.
- Autoclavable up to 250° F.

Anti-slide stop prevents stacked bins from shifting forward

Easy to carry with large handle molded onto back of bin



Large label area on front of bin

Reinforced side ribs add strength and prevent spreading when stacked

Super-Sized AkroBins

Model No.	Outside Dimensions						Inside Dimensions								Max. Capacity Per Bin	Stacking Capacity / =Qty. Stacked	Ctn. Qty.
	Inches			mm			Inches				mm						
	L	W	H	L	W	H	L	W	H	X	L	W	H	X			
30280	20	12 ³ / ₈	6	508	314	152	16 ⁷ / ₈	10 ¹ / ₁₆	5 ³ / ₈	15 ¹ / ₂	429	271	137	394	100lbs.	40lb./10	4
30281	20	12 ³ / ₈	8	508	314	203	16 ⁷ / ₈	10 ¹ / ₁₆	7 ³ / ₈	15 ¹ / ₂	429	271	187	394	150lbs.	50lb./7	3
30282	20	12 ³ / ₈	12	508	314	305	16 ⁷ / ₈	10 ¹ / ₁₆	11 ³ / ₈	15 ¹ / ₂	429	271	289	394	200lbs.	60lb./5	2
30283	20	18 ³ / ₈	12	508	467	305	16 ⁷ / ₈	16 ⁹ / ₁₆	11 ³ / ₈	15 ¹ / ₂	429	421	289	394	300lbs.	150lb./5	1
30290	29 ¹ / ₄	18 ³ / ₈	12	743	467	305	26 ¹ / ₈	16 ⁹ / ₁₆	11 ³ / ₈	24 ³ / ₄	664	421	289	629	300lbs.	150lb./5	1

One color per carton: Specify Red, Blue, or Yellow. Not recommended to hang on rack or panel systems.

Dollies

Model No.	Dimensions			Ctn. Qty.	Capacity Lbs.	Casters
	L	W	H			
RU842HR2018	20"	18 ³ / ₈ "	3 ¹ / ₂ "	1	500	2" Polyolefin
RU842HR2918	29 ¹ / ₄ "	18 ³ / ₈ "	3 ¹ / ₂ "	1	500	2" Polyolefin

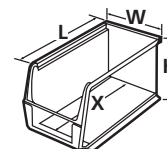

Stak-N-Store Bins



13014



13018



13017

- The perfect way to organize heavy, bulky items.
- Bins stack to form tall, stable storage arrangements on floors or standard industrial shelving.
- 75 lb. weight capacity.
- Color: Gray, Red, Blue.

Large comfort grip handles

Side ribs insure stability when stacked

Large radius corners and a curved upper lip add strength

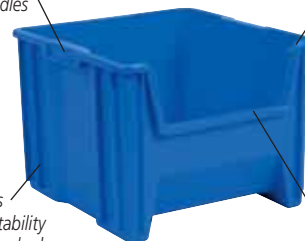

Wide-hopper front allows easy access to bulky items

Stak-N-Store Bins

Model No.	Outside Dimensions			Capacity Cu. Ft.	Ctn. Qty.
	L	W	H		
13014	17 ¹ / ₂	10 ⁷ / ₈	12 ¹ / ₂	.98	4
13017	15 ¹ / ₄	19 ⁷ / ₈	12 ⁷ / ₁₆	1.7	3
13018	17 ¹ / ₂	16 ¹ / ₂	12 ¹ / ₂	1.6	2

Order in carton quantities.

Stak-N-Store Bin Dollies

Model No.	Dimensions			Ctn. Qty.	Capacity Lbs.	Casters
	L	W	H			
RU843HR1617	16 ³ / ₈ "	15 ³ / ₄ "	4 ¹ / ₂ "	1	900 lbs.	3" Polyolefin
Compatible with Model 13018						
RU843HR1519	19 ¹ / ₄ "	14 ³ / ₈ "	4 ¹ / ₂ "	1	900 lbs.	3" Polyolefin
Compatible with Model 13017						

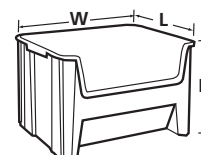

Stack bins together to form a storage system.

Shelf Bins



Shelf bins tilt out for complete access to contents.

- Shelf Bins outlast corrugated bins – paying for themselves in reduced replacement costs.
- Durable polypropylene bins can be fully loaded without bulging or cracking.
- Works with 12", 18", and 24" deep shelving, or vertical storage and retrieval units.
- Available in 13 sizes and 3 colors: Red, Yellow, and Blue.

Wide hopper front allows easy access

Built-in rear hanglock allows bin to tilt out for complete access

Molded-in label holder identifies contents

Optional dividers increase versatility

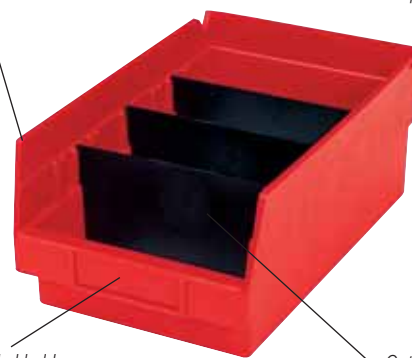

30120



30150



30158

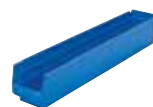

30124



30164

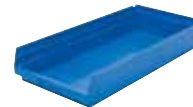

30174

Shelf Bins

Model No.	Outside Dimensions						Inside Dimensions						Ctn Qty.	Cups Per Bin		Optional Divider
	Inches			mm			Inches			mm				Small 30101	Large 30102	
	L	W	H	L	W	H	L	W	H	L	W	H				
12" Shelf Bin																
30110	11 ⁵ / ₈	2 ³ / ₄	4	295	70	102	10 ¹ / ₄	1 ⁵ / ₈	4	260	41	102	24	3	-	None
30120	11 ⁵ / ₈	4 ¹ / ₈	4	295	105	102	10 ¹ / ₄	3	4	260	76	102	24	5	2	40120
30130	11 ⁵ / ₈	6 ⁵ / ₈	4	295	168	102	10 ¹ / ₄	5 ¹ / ₂	4	260	140	102	12	9	4	40130
30150	11 ⁵ / ₈	8 ³ / ₈	4	295	219	102	10 ¹ / ₄	7 ¹ / ₈	4	260	181	102	12	11	4	40150
30170	11 ⁵ / ₈	11 ¹ / ₈	4	295	283	102	10 ¹ / ₄	10	4	260	254	102	12	15	6	40170
18" Shelf Bin																
30128	17 ⁷ / ₈	4 ¹ / ₈	4	454	105	102	16 ¹ / ₂	3	4	419	76	102	12	8	3	40120
30138	17 ⁷ / ₈	6 ⁵ / ₈	4	454	168	102	16 ¹ / ₂	5 ¹ / ₂	4	419	140	102	12	15	6	40130
30158	17 ⁷ / ₈	8 ³ / ₈	4	454	213	102	16 ¹ / ₂	7 ¹ / ₈	4	419	181	102	12	15	6	40150
30178	17 ⁷ / ₈	11 ¹ / ₈	4	454	283	102	16 ¹ / ₂	10	4	419	254	102	12	25	12	40170
24" Shelf Bin																
30124	23 ⁵ / ₈	4 ¹ / ₈	4	600	105	102	22 ¹ / ₈	3	4	562	76	102	12	11	4	40120
30164	23 ⁵ / ₈	6 ⁵ / ₈	4	600	168	102	22 ¹ / ₈	5 ¹ / ₂	4	562	140	102	6	21	8	40130
30184	23 ⁵ / ₈	8 ³ / ₈	4	600	213	102	22 ¹ / ₈	7 ¹ / ₈	4	562	181	102	6	25	8	40150
30174	23 ⁵ / ₈	11 ¹ / ₈	4	600	283	102	22 ¹ / ₈	10	4	562	254	102	6	35	16	40170

One color per carton. Specify color: Red, Yellow, or Blue.

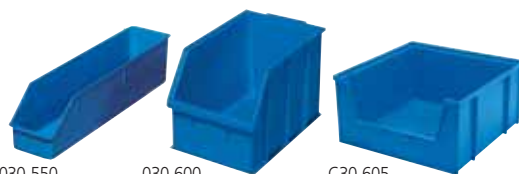
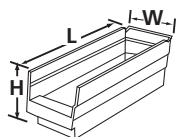

030-550

030-600

C30-605

Shelf Boxes

Model No.	Outside Dimension						Capacity	
	Inches			mm			cu. ft.	liters
	L	W	H	L	W	H		
030-550	24 ¹ / ₄	6	5 ³ / ₄	616	152	146	.84	23.8
030-600	18	10 ³ / ₈	10	457	263	254	.84	23.8
C30-605	16	16	8 ³ / ₁₆	406	406	208	.90	25.5

Optional Accessories:



Dividers

Black polypropylene dividers create compartments. Sizes to fit all bins except 30110. Each bin accepts up to 7 compartment dividers.

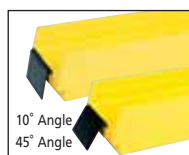

Extended Label Holders

Designed for larger bar code scanning. Label holders fit all shelf bins except the 30110.

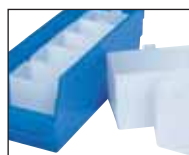

Bin Cups

Bin Cups lift out easily for parts retrieval and fit all Shelf Bins. (Refer to Shelf Bin chart for number of cups per bin.)

Dividers

Model No.	Fits Shelf Bins	Width	Pkg. Qty.
40120	30120, 30124, 30128	4 ¹ / ₈ "	24
40130	30130, 30138, 30164	6 ⁵ / ₈ "	24
40150	30150, 30158, 30184	8 ³ / ₈ "	24
40170	30170, 30174, 30178	11 ¹ / ₈ "	24

Extended Label Holders

Model No.	Description	Dimensions		Pkg. Qty.
		W	H	
40410	10° Angle	4"	2 ¹ / ₄ "	24
40445	45° Angle	4"	2 ¹ / ₄ "	24

Bin Cups

Model No.	Description	Dimensions			Ctn. Qty.
		L	W	H	
30101	Small Bin Cup	3 ¹ / ₄ "	2"	3"	48
30102	Large Bin Cup	5"	2 ³ / ₄ "	3"	24

Shelving Systems

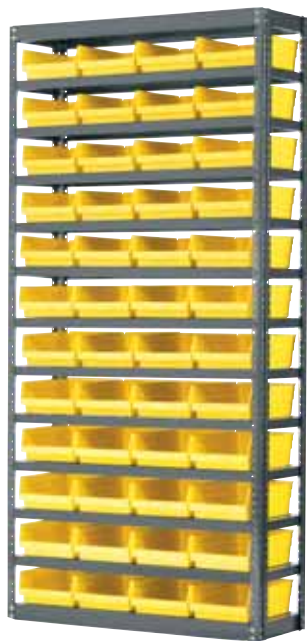

Shelf Bin Systems
13 shelf unit holds up to 96, 18" deep bins or 144, 12" deep bins

- 22-gauge steel with baked enamel finish.
- Shelving can be ordered independently or purchased with Akro-Mils Shelf Bins and Stak-N-Store Bins to create an efficient storage system.
- Easy to assemble with nuts and bolts only on the top and bottom shelves.
- Adjustable compression clips secure shelves.
- Closed base keeps debris and small parts from slipping underneath.
- Bin colors: Shelf Bins— Yellow, Stak-N-Store Bins— Gray.

12" Shelf Bin System 12"D x 36"W x 75"H

SKU Number	Description	Bin Model No.	Bin Dimensions L x W x H	Qty. of Bins
AS1275	Shelving, no Bins	—	—	—
AS1275110Y	Shelving with Bins	30110	11 ⁵ / ₈ " x 2 ³ / ₄ " x 4"	144
AS1275120Y	Shelving with Bins	30120	11 ⁵ / ₈ " x 4 ¹ / ₈ " x 4"	96
AS1275130Y	Shelving with Bins	30130	11 ⁵ / ₈ " x 6 ⁵ / ₈ " x 4"	60
AS1275150Y	Shelving with Bins	30150	11 ⁵ / ₈ " x 8 ³ / ₈ " x 4"	48
AS1275170Y	Shelving with Bins	30170	11 ⁵ / ₈ " x 11 ¹ / ₈ " x 4"	36

18" Shelf Bin System 18"D x 36"W x 75"H

SKU Number	Description	Bin Model No.	Bin Dimensions L x W x H	Qty. of Bins
AS1875	Shelving, no Bins	—	—	—
AS1875128Y	Shelving with Bins	30128	17 ⁷ / ₈ " x 4 ¹ / ₈ " x 4"	96
AS1875138Y	Shelving with Bins	30138	17 ⁷ / ₈ " x 6 ⁵ / ₈ " x 4"	60
AS1875158Y	Shelving with Bins	30158	17 ⁷ / ₈ " x 8 ³ / ₈ " x 4"	48
AS1875178Y	Shelving with Bins	30178	17 ⁷ / ₈ " x 11 ¹ / ₈ " x 4"	36

Stak-N-Store System 18"D x 42"W x 75"H

SKU Number	Description	Bin Model No.	Bin Dimensions L x W x H	Qty. of Bins	Bonus Bins*
AS187542	18" x 42" x 75" Shelving, no Bins	—	—	—	—
AS187513017	18" x 42" x 75" Shelving with Bins	13017	15-1/4" x 19-7/8" x 12-7/16"	10	2

*Due to case pack, Bonus Bins are included, at no extra charge.

New Stak-N-Store System 18"D x 36"W x 75"H

SKU Number	Description	Bin Model No.	Bin Dimensions L x W x H	Qty. of Bins	Bonus Bins*
AS187536	18" x 36" x 75" Shelving, no Bins	—	—	—	—
AS187513014	18" x 36" x 75" Shelving with Bins	13014	17 ¹ / ₂ " x 10 ⁷ / ₈ " x 12 ¹ / ₂ "	15	1
AS187513018	18" x 36" x 75" Shelving with Bins	13018	17 ¹ / ₂ " x 16 ¹ / ₂ " x 12 ¹ / ₂ "	10	-
AS1875ASSOR	18" x 36" x 75" Shelving with Bin Mix	13014	17 ¹ / ₂ " x 10 ⁷ / ₈ " x 12 ¹ / ₂ " (13014)	6	2
		13018	17 ¹ / ₂ " x 16 ¹ / ₂ " x 12 ¹ / ₂ " (13018)	6	-

*Due to case pack, Bonus Bins are included, at no extra charge.

Bonus!
2 extra bins included



AS187513017



Easy Shelf Adjustment:
Quickly change shelf height with compression clips

350-pound capacity per shelf
when assembled and installed per instructions.



AS187513018

Pick Rack Systems



Bench Pick Rack
Holds up to 24 bins on 3 shelves



Single Sided Pick Rack
Holds up to 96 bins on 8 shelves
Maximum 400 lb. weight capacity

Angled shelves
increase picking
efficiency

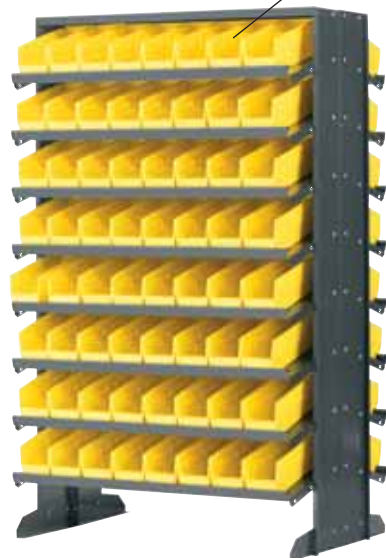

Double Sided Pick Rack
Holds up to 192 bins on 16 shelves
Maximum 800 lb. weight capacity

- Improve workspace organization and efficiency with rack and bin systems.
- Convenient, high-density storage with up to 192 bins.
- Easy to assemble.
- Angled shelves keep parts at the front of bins for easy access.
- Choose from 4 styles available separately or in a package with Akro-Mils yellow Shelf Bins.

Single Sided Pick Rack 12"D x 36"W x 60"H

SKU Number	Description	Bin Model No.	Bin Dimensions L x W x H	Qty. of Bins	Bonus Bins*
APRS	Single Sided Pick Rack, no Bins	—	—	—	—
APRS110Y	Rack with Bins	30110	11 ⁵ / ₈ " x 2 ³ / ₄ " x 4"	96	—
APRS120Y	Rack with Bins	30120	11 ⁵ / ₈ " x 4 ¹ / ₈ " x 4"	64	8
APRS130Y	Rack with Bins	30130	11 ⁵ / ₈ " x 6 ⁵ / ₈ " x 4"	40	8
APRS150Y	Rack with Bins	30150	11 ⁵ / ₈ " x 8 ³ / ₈ " x 4"	32	4
APRS170Y	Rack with Bins	30170	11 ⁵ / ₈ " x 11 ¹ / ₈ " x 4"	24	—

*Due to case pack, Bonus Bins are included, at no extra charge.

Bench Pick Rack 12"D x 36"W x 21"H

SKU Number	Description	Bin Model No.	Bin Dimensions L x W x H	Qty. of Bins
APRBENCH	Bench Pick Rack, no Bins	—	—	—
APRBENCH 120	Bench Pick Rack with Bins	30120	11 ⁵ / ₈ " x 4 ¹ / ₈ " x 4"	24
APRBENCH 150	Bench Pick Rack with Bins	30150	11 ⁵ / ₈ " x 8 ³ / ₈ " x 4"	12

Double Sided Pick Rack 24"D x 36"W x 60"H

SKU Number	Description	Bin Model No.	Bin Dimensions L x W x H	Qty. of Bins	Bonus Bins*
APRD	Double Sided Pick Rack, no Bins	—	—	—	—
APRD110Y	Rack with Bins	30110	11 ⁵ / ₈ " x 2 ³ / ₄ " x 4"	192	—
APRD120Y	Rack with Bins	30120	11 ⁵ / ₈ " x 4 ¹ / ₈ " x 4"	128	16
APRD130Y	Rack with Bins	30130	11 ⁵ / ₈ " x 6 ⁵ / ₈ " x 4"	80	4
APRD150Y	Rack with Bins	30150	11 ⁵ / ₈ " x 8 ³ / ₈ " x 4"	64	8
APRD170Y	Rack with Bins	30170	11 ⁵ / ₈ " x 11 ¹ / ₈ " x 4"	48	—

*Due to case pack, Bonus Bins are included, at no extra charge.

Mobile Kit

SKU Number	Description
APRDMOBILE	Mobile Kit For Double Sided Pick Rack



Double Sided Pick Rack & Mobile Kit
Creates a mobile double sided pick rack
Maximum 500 lb. weight capacity

Economy Bins



A large bar code label area makes content identification simple.

- The only small parts bin that can nest and stack.
- Organize work areas and expand storage space without adding shelving.
- Versatile Economy Bins make full use of shelf depth on 12" or 18" deep shelving and stack to fill space between shelves.
- Sturdy one-piece construction is water, rust, and corrosion-proof.
- Unaffected by weak acids and alkalis.
- Molded from co-polymer polypropylene.
- Guaranteed not to crack or break under normal load conditions as stated in our 1-year limited warranty.
- Autoclavable up to 250° F
- Available in 5 sizes.

Unique post & rib design allows the bins to stack and nest
 Tapered corners keep small parts from becoming trapped
 Stacking posts allow same-width stacking

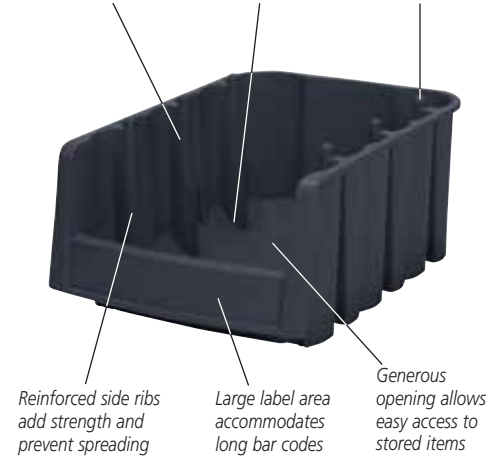

30796 Black



30716 Black



30776 Black



30718 Black



30778 Black

Economy Bins

Model No.	Outside Dimensions						Ctn. Qty.
	Inches			mm			
	L	W	H	L	W	H	
30796 Black	8 $\frac{1}{8}$	6 $\frac{5}{8}$	5	225	168	127	10 each
30716 Black	11 $\frac{7}{8}$	6 $\frac{5}{8}$	5	302	168	127	10 each
30776 Black	17 $\frac{7}{8}$	6 $\frac{5}{8}$	7	454	168	178	10 each
30718 Black	11 $\frac{7}{8}$	8 $\frac{3}{8}$	5	302	213	127	8 each
30778 Black	17 $\frac{7}{8}$	8 $\frac{3}{8}$	7	454	213	178	8 each

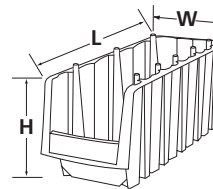

1800 Series AkroBins®



30358

- Storage systems for large, heavy, and bulky items.
- Concentrate storage, reduce and control inventories, minimize material handling, and organize supplies.
- Strong, durable co-polymer polypropylene construction.
- Designed to fit on 18" shelving for concentrated storage.
- One black cross-wise divider included per bin.
- Available in 2 sizes: 8 $\frac{1}{4}$ " and 11" width.
- Color: Beige.

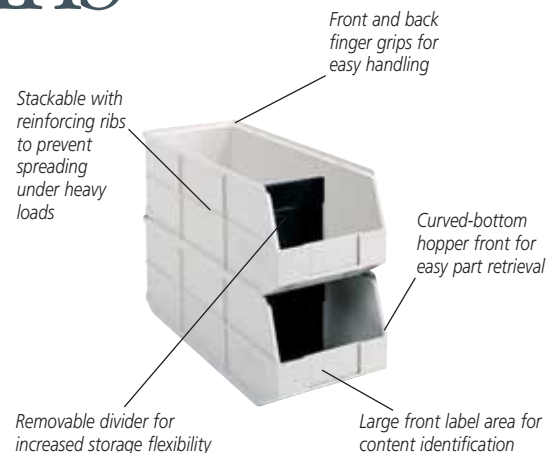

Removable divider for increased storage flexibility

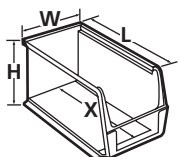

1800 Series AkroBins

Model No.	Outside Dimensions						Inside Dimensions						Ctn. Qty.	Dividers Model No.	Pkg. Qty.	Capacity Lbs.		
	Inches			mm			Inches			mm								
	L	W	H	L	W	H	L	W	H	X	L	W	H	X				
30348	20 $\frac{1}{2}$	8 $\frac{1}{4}$	7	521	210	178	20	7 $\frac{3}{8}$	6 $\frac{1}{2}$	20	508	187	165	508	6	40348	6	60
30358	20 $\frac{1}{2}$	11	7	521	279	178	20	10 $\frac{1}{8}$	6 $\frac{1}{2}$	20	508	257	165	508	6	40358	6	75

Order in carton quantities.

ESD Containers

AkroBins®

- Akro-Mils ESD containers dissipate electrostatic charges which can severely damage sensitive electronic components.
- Sturdy, one-piece construction is water, rust, and corrosion proof, and heat resistant to 300°F



Hanging Systems

- Storage systems provide convenient parts storage and retrieval.
- Six options let you choose the system that works best for you.

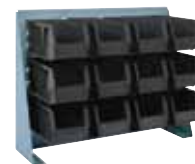

Shelf Bins

- Shelf Bins provide an economical solution to electronic component storage problems.
- Works with 12", 18", and 24" deep shelving or vertical storage and retrieval units.

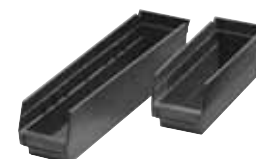

Grids

- Grids are compatible with most racks, shelving, and automated material handling equipment.
- Ribbed design gives added strength.



ESD AkroBins (Black Only)

Model No.	Outside Dimensions						Inside Dimensions						Bin Load Capacity On Rack	Ctn Qty.
	Inches			mm			Inches			mm				
	L	W	H	L	W	H	L	W	H	X	L	W	H	X
30210ESD	5 $\frac{3}{8}$	4 $\frac{1}{8}$	3	136	105	76	4 $\frac{3}{4}$	3 $\frac{7}{16}$	2 $\frac{1}{16}$	4	121	87	71	102
30220ESD	7 $\frac{3}{8}$	4 $\frac{1}{8}$	3	187	105	76	6 $\frac{3}{4}$	3 $\frac{7}{16}$	2 $\frac{1}{16}$	6	171	87	71	152
30230ESD	10 $\frac{7}{8}$	5 $\frac{1}{2}$	5	276	140	127	10 $\frac{1}{4}$	4 $\frac{3}{8}$	4 $\frac{3}{4}$	9	260	111	121	229
30235ESD	10 $\frac{7}{8}$	11	5	276	279	127	10 $\frac{1}{4}$	10	4 $\frac{3}{4}$	9	260	254	121	229
30240ESD	14 $\frac{3}{4}$	8 $\frac{1}{4}$	7	375	210	178	14	6 $\frac{9}{16}$	6 $\frac{3}{4}$	12	356	167	171	305

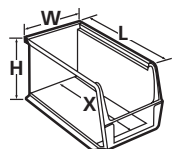

Louvered Panels And Bench Racks

Use this chart to determine the quantity of same-size AkroBins required to fill each panel.

See pages 5-6 for hanging system features.

Model No.	Description	Ctn. Qty.	AkroBin Model No. (Bin Wt. Capacity)				
			30210ESD (10 lbs.)	30220ESD (10 lbs.)	30230ESD (30 lbs.)	30235ESD (50 lbs.)	30240ESD (60 lbs.)
30618	18" x 19" Louvered Panel	4	16	16	9	-	-
30636	35 $\frac{3}{4}$ " x 19" Louvered Panel	4	32	32	18	9	8
98600	27 $\frac{3}{4}$ " Bench Rack	1	30	30	12	6	6
98636	36" Bench Rack	1	40	40	18	9	8



Grounding wire 98100 – Conducts static charges away from the storage system. Designed to convert existing Akro-Mils racks and hanging systems (see pages 5-6).

Louvered Floor Racks

Use this chart to determine the quantity of same-size AkroBins required to fill each floor rack.

Bins sold separately.

Model No.	Description	Dimensions			AkroBin Model Number							
		Inches		mm	30210ESD	30220ESD	30230ESD	30235ESD	30240ESD			
		L	W	H	L	W	H					
30626	Double-Sided Snap Fastener Louvered Rack	36	20	60	914	508	1524	192	192	108	54	48
30653	Louvered Floor Rack	35 $\frac{3}{4}$	32	75 $\frac{1}{8}$	908	813	1908	288	288	144	72	72

ESD Shelf Bins

Model No.	Outside Dimension						Inside Dimension						Ctn Qty.
	Inches			mm			Inches			mm			
	L	W	H	L	W	H	L	W	H	L	W	H	
30120ESD	11 $\frac{1}{2}$	4 $\frac{1}{8}$	4	295	105	102	10 $\frac{1}{4}$	3	4	260	76	102	24
30128ESD	17 $\frac{1}{8}$	4 $\frac{1}{8}$	4	454	105	102	16 $\frac{1}{2}$	3	4	419	76	102	12
30124ESD	23 $\frac{3}{8}$	4 $\frac{1}{8}$	4	600	105	102	22 $\frac{1}{2}$	3	4	562	76	102	12

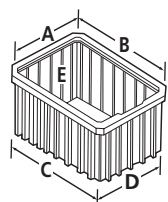
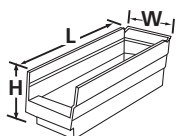

ESD Grids

Model No.	Outside Dimensions						Inside Dimensions									Ctn. Qty.	
	Inches			mm			Inches					mm					
	L	W	H	L	W	H	A	B	C	D	E	A	B	C	D	E	
33164ESD	16 $\frac{1}{2}$	10 $\frac{7}{8}$	4	419	276	102	9 $\frac{3}{8}$	14 $\frac{15}{16}$	14 $\frac{13}{16}$	9 $\frac{3}{16}$	3 $\frac{7}{8}$	238	379	376	233	98	12
33224ESD	22 $\frac{3}{8}$	17 $\frac{3}{8}$	4	568	441	102	15 $\frac{1}{16}$	20 $\frac{1}{16}$	20	15	3 $\frac{7}{8}$	383	510	508	381	98	6





18-19
Nest & Stack Totes
Durable NST's for storage, transfer & shipping applications.



26-27
Heavy-Duty Industrial Boxes
Rugged boxes and trays for the most demanding applications.



29
Specialty Containers
Containers for unique applications.



20-21
Attached Lid Containers
Reusable ALC's for shipping, distribution, and storage.

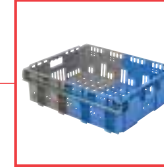

30-31
Food Processing Containers
Nesting and stacking containers designed for food applications.



22
Detached Lid Containers
Durable containers and separate lids for storage and distribution.



27
Tote Caddy
Convenient, portable tote caddy for easy supplies transport.



32-33
Bulk Boxes
A variety of Bulk Box sizes for large, hard-to-move items.



23
Akro-Grids
Organize small parts with these colorful, dividable containers.



28
Akro-Tub & Tub Rack
Heavy-duty tub & rack for manufacturing, distribution, and food industries.

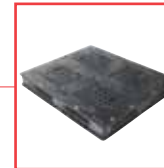

34-35
Pallets
Light to heavy-duty pallets for manufacturing, distribution, and food industries.



24-25
Straight Wall Containers
Reusable SWC's provide efficient cubing on pallets and in trucks.



29
Agricultural Containers
Containers designed to maintain freshness and safeguard fragile produce.

Totes, Containers & Pallets

Nest & Stack Totes



Nest & Stack Totes stack when full; turn 180° and nest when empty.

- Extremely durable industrial-grade totes.
- Gray NST's are manufactured from FDA-approved materials.
- Available in 9 sizes and 3 colors: Red, Blue, and Gray.



NST's

Model No.	Outside Dimensions						Inside Dimensions									NST Ctn. Qty.	Capacity			
	Inches			mm			Inches			mm			Cu. Ft.	Lbs.	Kg					
	L	W	H	L	W	H	A	B	C	D	E	A	B	C	D	E				
35180*	18	11	6	457	280	152	10	16	15 1/4	9 3/8	5 1/8	254	406	387	238	149	6	.50	-	-
35185	18	11	9	457	280	229	10	16	15 1/4	9 3/8	8 3/8	254	406	384	232	225	6	.76	-	-
35190	19 1/2	15 1/2	10	495	394	254	14 1/2	17	16	13 3/4	9 7/8	368	432	406	337	251	6	1.20	-	-
35195	19 1/2	15 1/2	13	495	394	330	14 1/2	17	15 7/8	13 3/8	12 7/8	368	432	403	340	327	6	1.70	-	-
35200	19 1/2	13 1/2	8	495	343	203	12 3/8	17 7/8	16 3/8	11 1/2	7 7/8	314	454	416	292	200	6	.80	-	-
35225	23 1/2	19 1/2	10	597	495	254	18 1/4	20 7/8	19 3/8	16 7/8	9 7/8	464	530	492	429	251	3	2.00	-	-
35230	23 1/2	19 1/2	13	597	495	330	18 1/8	20 7/8	19 1/2	16 7/8	12 7/8	460	530	495	429	327	3	2.60	-	-
35240	23 1/2	15 1/2	12	597	394	305	14 1/4	20 7/8	19 5/8	13	11 7/8	362	530	498	330	302	3	1.70	-	-
35300	29 1/2	19 1/2	15	750	495	381	18 1/4	26 5/8	25 1/8	16 5/8	14 7/8	464	676	638	422	378	3	3.70	-	-
SN18110600	18	11	5 1/4	460	280	148	-	-	15	8	5 1/4	-	-	381	203	148	-	-	30	14
SN21141200	21	14	12	535	355	305	-	-	17	8	11	-	-	432	203	279	-	-	70	32
SN19131202	19 1/4	12 3/4	12 1/4	489	324	311	-	-	14 5/8	10 5/8	11 1/2	-	-	372	270	292	-	-	70	32
SN24201302	24 1/16	20	13	610	508	330	-	-	19 3/8	17 5/16	12 5/16	-	-	493	440	313	-	-	70	32
SN29191002	28 3/4	18 3/4	10 3/8	730	475	265	-	-	23 1/16	15 5/8	9 7/16	-	-	586	397	240	-	-	100	45
SN20161200	20	16	12	510	405	305	-	-	17 1/2	11 1/8	11 1/8	-	-	445	283	283	-	-	60	27
FB32181200	31 5/8	18 3/8	12	800	465	305	-	-	24 13/16	15 9/16	10 1/2	-	-	630	395	267	-	-	125	56
SN24160800	23 3/8	15 5/8	7 9/10	599	401	200	-	-	21 5/8	14 3/8	7	-	-	554	366	178	-	-	44	20
SN24160822	23 3/8	15 5/8	7 9/10	599	401	200	-	-	21 5/8	14 3/8	7	-	-	554	366	178	-	-	44	20
SN24161200	23 3/8	15 5/8	11 1/4	599	401	300	-	-	22	14 3/8	10 1 1/16	-	-	558	366	272	-	-	44	20
SN24161222	23 3/8	15 5/8	11 1/4	599	401	300	-	-	22	14 3/8	10 1 1/16	-	-	558	366	272	-	-	44	20
SN24161220	23 3/8	15 5/8	11 1/4	599	401	300	-	-	22	14 3/8	10 1 1/16	-	-	558	366	272	-	-	44	20
SN24161620	23 3/8	15 5/8	15 5/8	599	401	401	-	-	22	14 3/8	14 1 1/16	-	-	558	366	373	-	-	44	20
SN24161622	23 3/8	15 5/8	15 5/8	599	401	401	-	-	22	14 3/8	14 1 1/16	-	-	558	366	373	-	-	44	20

One color per carton. Specify Red, Blue, or Gray. * NST 35180 is made of high-density polypropylene.

Optional Accessories:



Label Holders

Model No. 35101. Clear plastic label holders attach easily to NST's, with or without the lid in place. Holders accommodate labels up to 3" x 5". One size fits all totes.

Label Holders

Model No.	Package Qty.
35101	6



Lids

Lids snap tight to protect contents. See lids chart for matching lid size.

Nest & Stack Totes Dollies

Model No.	Dimensions			Ctn. Qty.	Capacity Lbs.	Casters
	L	W	H			
RU843HR1828	27 5/8"	17 3/4"	4 3/4"	1	900 lbs.	3" Polyolefin
Compatible with Model 35300						
RU843HR1822	21 3/4"	17 3/4"	4 3/4"	1	900 lbs.	3" Polyolefin
Compatible with Models 35225 and 35230						
RU843HR1422	21 7/8"	14"	4 3/4"	1	900 lbs.	3" Polyolefin
Compatible with Model 35240						

Lids Chart

NST Model No.	Optional Lids Model No.	Lid Ctn. Qty.
35180	35181	6
35185	35181	6
35190	35191	6
35195	35191	6
35200	35201	6
35225	35231	3
35230	35231	3
35240	35241	3
35300	35301	3

Nest & Stack Totes solid steel Dollies are available for efficient parts transport.

Bi-Color Stack & Nest Totes

- Stack when loaded to protect contents, nest when empty with 180° turn - 50% nesting ratio.

- Available in solid and ventilated versions.
- Modular to 48" x 45" pallet.
- Compatible with automated handling equipment.
- Standard colors include Gray/Red, Gray/Blue, Gray/Green, Green/Blue, Lt. Blue/Blue.

Solid or vented styles for flexibility to fit applications from food to automotive parts

Bi-Colors clearly identify stack and nest positions: alternate colors - nested, same color - stacked

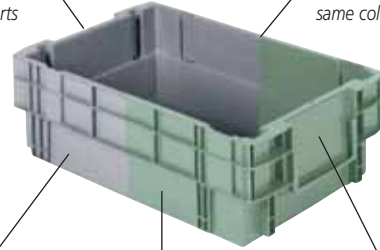

Straight walls provide maximum internal and external space usage

Smooth surfaces for easy cleaning

Identification areas for labels and tags



Unique, one-piece design allows for optional dividers, cradles, and dunnage.



Bi-Color Stack & Nest Totes

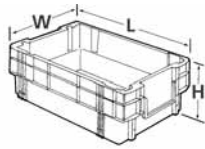

Model No.	Outside Dimensions						Inside Dimensions Bottom						Capacity	
	Inches			mm			Inches			mm			Lbs.	Kg
	L	W	H	L	W	H	L	W	H	L	W	H		
SN15120709	15	12	7½	381	305	191	11½	10¾	7	293	264	178	35	15
SN24150709	24	15	7½	610	381	191	20½	13¾	7	521	340	178	35	15
SN24150999	24	15	9½	610	381	240	20½	13¾	9	521	340	229	45	20
SN24220913	24	22½	9	610	572	229	21¼	20½	8½	553	520	218	45	20
SN24221113	24	22	11	610	559	279	21¼	20½	10¾	553	520	269	45	20
11020	23¾	15¼	4¾	600	400	117	-	-	-	-	-	-	-	-

KeepBoxes™

- KeepBoxes stack and nest for optimal space usage
- Clearly identify contents through transparent bases
- Attached lids snap securely closed to protect contents from dust or damage

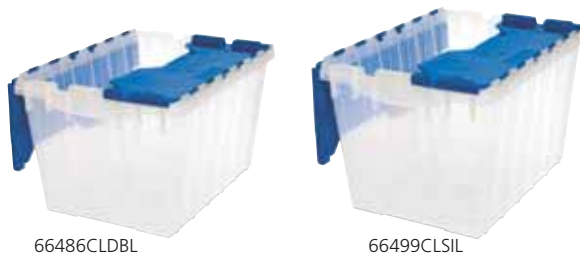

Tilt & Locks

Model No.	Description	L	Inches W	H	L	mm W	H	Ctn. Qty.
66486CLDBL	12-Gallon KeepBox	21½	15	12½	546	381	318	6
66499CLSIL	68-Quart KeepBox	23	16¾	14	584	422	356	6
66497CLDGN	18-Gallon KeepBox	21½	15	17	546	381	432	3

Attached Lid Containers



Designed to stack together for easy pallet loading.

- Reusable shipping, distribution, order picking, and storage containers.
- Attached lids snap securely closed to protect contents from dust or damage.
- ALC's stack and nest for optimal space use.
- Containers interwork for easy pallet loading.
- Color: Gray, Blue.

Reinforced hinge pins for years of smooth lid operation

Padlock eye on both ends accommodates security ties

Textured bottoms provide a sure grip on conveyor belts

Strong molded-in handle grips are ergonomically designed for easy lifting and carrying



Akro-ALC's

Model No.	Outside Dimensions Inches			Outside Dimensions mm			Inside Dimension Inches			Inside Dimension mm			Cubic Ft.	Capacity Gal.	Ctn. Qty.				
	L	W	H	L	W	H	L	W	H	L	W	L				W			
39085	21½	15	9	546	381	229	19¾	14½	8¾	502	368	219	18⅞	13¼	468	337	1.12	8.5	6
39120	21½	15	12½	546	381	318	19¾	14½	12	502	368	305	18⅞	13¼	468	337	1.62	12	6
39170	21½	15	17	546	381	432	19¾	14½	16⅞	502	368	429	18⅞	13¼	468	337	2.28	17	3

Order in carton quantities.

Akro-ALC's Dolly

Model No.	Dimensions			Ctn. Qty.	Capacity Lbs.	Casters
	L	W	H			
RU843HR1420	19¾"	14½"	4¾"	1	900 lbs.	3" Polyolefin

Compatible with Models 39085, 39120, 39170

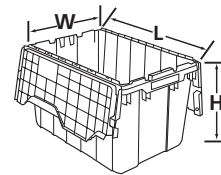

Attached Lid Containers solid steel Dolly (Model No. RU843HR1420) is compatible with Models 39085, 39120, 39170 for efficient parts transport.

Industrial Attached Lid Containers

- Heavy-duty containers for industrial applications.
- Stack and nest design for maximum space usage.
- Injection-molded HDPE construction resists impact, moisture, and most chemicals.
- Tie holes in both ends to provide additional security.
- Containers interwork for easy pallet loading.
- Model AR15141300 is ideal for liquid distribution applications - it holds four, one-gallon jugs or nine 750 ml bottles.

Closed and open style handles available on some models

Reinforced sides and corners for added protection against breakage

Interlocking fingers on lid provide secure closure and add strength for secure stacking

Textured ID areas on lids and sides for easy application and removal of labels and barcodes



Totes, Containers & Pallets



Attached lid containers cube pallets and allow better space utilization of trailers and warehouses.



AR15141300



AR20120702



AR21150902



AR21151202



AR21151700



AS22131202



AP22161000



AR24201202



AR27170902



See pages 68-70 for a selection of wood, plastic and steel dollies.



AR27171202



AS28211502



AS34242012

Attached Lid Containers

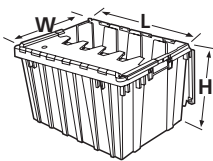

Model No.	Outside Dimensions						Inside Dimensions Bottom						Capacity	
	Inches			mm			Inches			mm			Lbs.	Kg
	L	W	H	L	W	H	L	W	H	L	W	H		
AR15141300	14 ³ / ₄	13 ¹ / ₂	13 ⁷ / ₁₆	374	343	338	11 ¹ / ₄	11 ¹ / ₄	11 ⁷ / ₁₆	286	286	302	50	23
AR20120702	20	11 ¹ / ₁₆	7 ¹ / ₂	510	295	190	16 ⁷ / ₈	9 ¹ / ₁₆	6 ¹ / ₁₆	430	245	153	40	18
AR21150902	21 ³ / ₄	15 ¹ / ₄	9 ⁵ / ₈	552	387	245	18 ³ / ₈	13	8 ¹ / ₂	467	330	215	60	27
AR21151202	21 ³ / ₄	15 ¹ / ₄	12 ¹³ / ₁₆	552	387	325	17 ⁷ / ₈	12 ¹ / ₂	11 ¹ / ₈	455	320	285	60	27
AR21151700	21 ³ / ₄	15 ¹ / ₄	17	552	387	431	17 ⁷ / ₁₆	12 ⁷ / ₁₆	15 ¹ / ₁₆	455	316	404	60	27
AS22131202	22 ³ / ₈	13	12 ⁷ / ₈	567	330	327	18 ⁴ / ₈	10 ³ / ₃₂	11 ¹ / ₈	483	254	298	60	27
AP22161000	21 ³ / ₄	16 ¹ / ₂	10 ¹ / ₄	552	419	260	18 ⁹ / ₃₂	14	8 ⁵ / ₈	464	356	222	60	27
AR24201202	24	19 ¹ / ₂	12 ⁵ / ₈	610	495	320	20 ¹ / ₂	16 ¹ / ₃₂	10 ⁵ / ₈	520	421	279	80	36
AR27170902	27 ¹ / ₁₆	16 ⁷ / ₈	9 ⁵ / ₈	687	430	240	23 ⁹ / ₁₀	14 ³ / ₃₂	8	610	360	203	80	36
AR27171202	27 ¹ / ₈	16 ⁷ / ₈	12 ¹ / ₂	689	430	320	23 ¹ / ₂	13 ³ / ₈	10 ⁹ / ₁₀	600	350	278	100	45
AS28211502	28	20 ³ / ₄	15 ⁷ / ₁₆	710	530	390	25	18	14	635	460	355	100	45
AS34242012	34	24	19 ⁵ / ₈	865	610	500	29 ⁹ / ₁₀	19 ¹ / ₂	18 ³ / ₃₂	760	495	460	100	45

Attached Lid Containers Cont.



Dual-purpose attached lid opens out for full access to container when loading.



In flow racks or on shelving, the quarter-half lids open up and back for access through the top of the container.



On the picking or assembly line, the hinged front gate drops down for complete, easy product access.

BinBox™ Container

- Bi-directional attached lid allows easy loading, secure shipping, and quick picking.
- Lid can be secured with ties for extra spillage/theft protection.

Reinforcing ribs on lid add strength for stacking

Nesting stops prevent container jamming

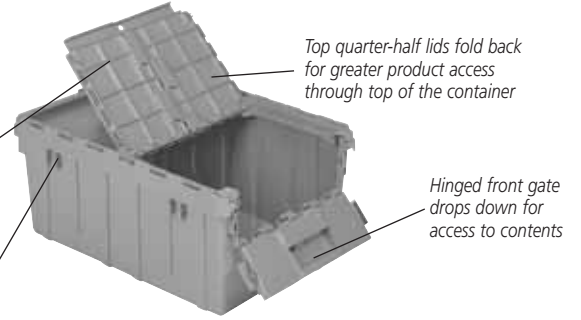

BinBox™ Container

Model No.	Size						Capacity	
	Inches			mm			Lbs.	Kg
	L	W	H	L	W	H		
AB21150900	21¾	15¼	9¼	552	387	235	60	27

Bi-Fold Lid Containers

- Ideal for distribution of small orders - up to .78 cubic feet.
- Interwork with 21" x 15" attached lid containers.
- The attached-recessed lid flaps fold in half and lock against the side of the container for ease of conveying and nesting.
- Interlocking fingers on lid provides secure closure and stacking strength.

Textured areas allow for identification label placement and easy label removal

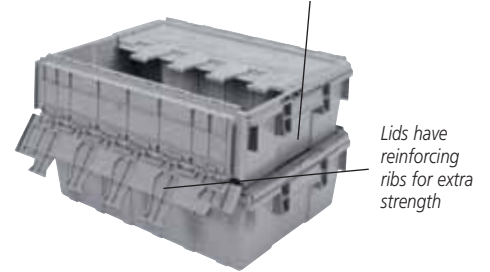

Bi-Fold Lid Containers

Model No.	Size						Capacity	
	Inches			mm			Lbs.	Kg
	L	W	H	L	W	H		
AF21150602	21½	15¼	6⅝	546	387	168	60	27

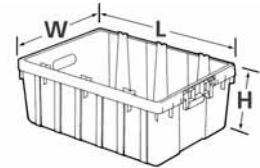

Detached Lid Containers



- Lids are available in recessed style for secure stacking, strapping style for banding use, and high cube for additional storage space.
- Containers stack, nest, and interwork.
- Textured bottom standard on most models to prevent slippage on conveyors. Smooth bottoms also available.
- 24" x 20" containers cube 48" x 40" pallets, 4 per layer.

Recessed lid creates a retaining wall to form secure stacks



Handles

- Several handle styles available
- Open for easy gripping.
 - Closed for increased security.
 - Ergonomic for comfortable lifting.
 - Handle styles vary by model.

Detached Lid Containers

Model No.	Size						Capacity	
	Inches			mm			Lbs.	Kg
	L	W	H	L	W	H		
21" x 15"								
DL21150512	21¾	15¼	5¾	543	387	170	50	23
DL21150712	21¾	15¼	7⅞	543	387	200	50	23
DL21150900	21¾	15¼	9⅞	543	387	243	60	27
DL21151202	21¾	15¼	12¾	543	387	314	-	-
24" x 20"								
DL24200614	24	20	6¾	610	508	171	50	23
DL24201014	24	20	10¾	610	508	264	80	36
DL24201202	24	20	12¾	610	508	314	80	36

21" x 15" Detached Lids

Model No.	Description	Dimensions		
		L"	W"	H"
DR21150100	Recessed Lid mm/kg	21¾ 543	15¼ 384	1¼ 30

24" x 20" Detached Lids

Model No.	Description	Dimensions		
		L"	W"	H"
DR24200100	Recessed Lid mm/kg	24 610	20 508	1⅞ 29

Akro-Grids



Modular box dividers maximize space.

- Versatile work-in-process transfer containers.
- Injection molded from high-density polyethylene.
- Resist most solvents and chemicals.
- Compatible with most racks, shelving, and automated material handling equipment.
- Ribbed design adds strength.
- Dividers allow subdivision of the containers down to a 1¼" square compartment size.
- Dividers, lids, and label holders sold separately.
- Available in 8 sizes and 3 colors: Red, Blue, or Gray.
- Models 33164 and 33224 are available with ESD protection (see page 15).

Divider slots allow you to create hundreds of different compartment sizes

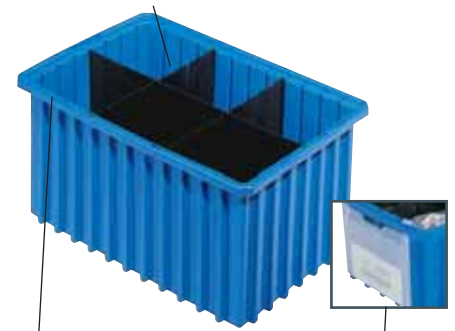

Strong stacking rims and external ribbing provide added strength

Optional label holders for content identification

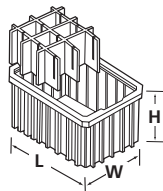

Outside Dimension

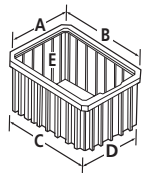

Inside Dimension



33105



33166



33168

Akro-Grids

Model No.	Outside Dimensions			Inside Dimensions					Capacity Cu. Ft.	Weight Capacity Cm	Ctn. Qty.									
	Inches L	Inches W	Inches H	Inches																
33105	10½	8¼	5	276	210	127	6⅛	9⅞	9⅞	6½	4¾	170	237	232	165	117	.16	.004	25	20
33164	16½	10⅞	4	419	276	102	9¾	14⅛	14⅛	9¾	3¾	238	380	376	233	98	.29	.008	20	12
33166	16½	10⅞	6	419	276	153	9¾	14⅞	14¾	9¾	5⅞	237	378	375	232	141	.44	.012	35	8
33168	16½	10⅞	8	419	276	203	9¾	14⅛	14⅛	9¾	7⅞	237	380	371	230	192	.59	.016	40	6
33220	22¾	17¾	10	568	441	254	15¼	20½	19¾	14¾	9¾	387	511	505	378	251	1.66	.047	50	2
33224	22¾	17¾	4	568	441	102	15¼	20¼	20	15	3¾	383	510	508	381	98	.61	.017	30	6
33226	22¾	17¾	6	568	441	153	15¼	20½	19¾	14¾	5¾	384	511	505	378	149	.96	.027	40	4
33228	22¾	17¾	8	568	441	203	15¼	20½	19¾	14¾	7⅞	384	511	505	378	189	1.30	.036	50	3

One color per carton. Specify Red, Blue, or Gray.



Solid steel dolly for efficient parts transport

AkroGrids Steel Dolly

Model No.	Dimensions L	Dimensions W	Dimensions H	Ctn. Qty.	Capacity Lbs.	Casters
RU843HR1621	21¾"	16¾"	4¾"	900 lbs.	1	3" Polyolefin

Compatible with Models 33220, 33224, 33226, 33228

Optional Accessories:

Dividers



Dividers allow sub-division of the containers down to a 1¼" square compartment size. Black.

Long Divider	Short Divider	Fits Grid No.	Pkg. Qty.
42105 (5)	41105 (7)	33105	6
42164 (7)	41164 (11)	33164	6
42166 (7)	41166 (11)	33166	6
42168 (7)	41168 (11)	33168	6
42220 (11)	41220 (15)	33220	6
42224 (11)	41224 (15)	33224	6
42226 (11)	41226 (15)	33226	6
42228 (11)	41228 (15)	33228	6

(Max. # of dividers)

Clear Plastic Covers



Clear plastic dust covers keep contents clean yet visible. Molded corner guides provide secure stacking.

Model No.	Fits Grid No.	Ctn. Qty.
33101	33105	10
33161	33166, 33168, 33164	4
33221	33228, 33220, 33226, 33224	3

Label Holders



Clear plastic label holders snap securely on any side of the container.

Model No.	Description	Pkg. Qty.
35010	Fits all Akro-Grids, except 33164 and 33224	6
35011	Fits grids No. 33164, 33224	6

Straight Wall Containers

- Reusable shipping, storage, and work-in-process containers.
- Straight walls provide efficient internal and external space usage.
- Solid-sided containers have smooth inner walls for easy, sanitary cleaning.
- Mesh-sided containers allow hot or cold air ventilation.
- Injection-molded from high-density polyethylene.
- Available in 4 sizes and 3 styles.
- Modular design cubes 48" x 45" and 48" x 40" pallets.
- Interworking sizes allow mixed stacking on pallets.
- Compatible with automated handling systems.
- SW prefix denotes standard bottom.
- SX prefix denotes cross cube bottom.
- Lids snap tightly in place protecting contents from contaminants. Tie holes allow lids to be secured with ties.
- Color: Gray.

Straight, smooth interior walls allow for maximum cube utilization and easy insertion of dunnage

Reinforced corner ribbing provides maximum column strength for secure stacking



Deep, ergonomic handles for enhanced comfort, efficiency, and safety when lifting

Large label areas on all four sides

One-inch wall thickness

Open .72 x .90 mesh pattern allows high visibility and good airflow

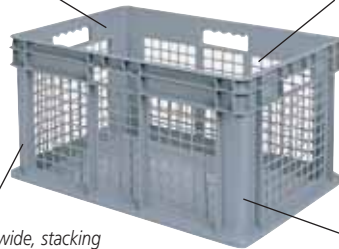

Strong, 1" wide, stacking rims and external ribbing provide added strength

Straight walls provide efficient cubing in trucks and on pallets



Handholes on all four sides provide an easy grip from any angle.

Three Styles Per Size:

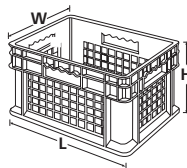

Mesh Base/Mesh Sides



Solid Side/Solid Base



Solid Base/Mesh Sides

SWC's

Mesh Side & Base	Mesh Side w/Solid Base	Solid Side & Base	Outside Dimensions						Inside Dimensions						Ctn. Qty.
			Inches			mm			Inches			mm			
			L	W	H	L	W	H	L	W	H	L	W	H	
37208	37278	37288	15 ³ / ₄	11 ³ / ₄	8 ¹ / ₄	400	298	210	14 ¹ / ₄	10 ¹ / ₄	8	362	260	203	
37608	37678	37688	23 ³ / ₄	15 ³ / ₄	8 ¹ / ₄	603	400	210	22 ¹ / ₄	14 ¹ / ₄	8	565	362	203	
37612	37672	37682	23 ³ / ₄	15 ³ / ₄	12 ¹ / ₄	603	400	311	22 ¹ / ₄	14 ¹ / ₄	12	565	362	305	
37616	37676	37686	23 ³ / ₄	15 ³ / ₄	16 ¹ / ₂	603	400	410	22 ¹ / ₄	14 ¹ / ₄	16	565	362	406	

Order in carton quantities.



Solid steel dolly for efficient parts transport

Straight Wall Container Dolly

Model No.	Dimensions			Ctn. Qty.	Capacity Lbs.	Casters
	L	W	H			
RU843HR1624	24 ³ / ₈ "	16 ³ / ₈ "	4 ³ / ₄ "	900 lbs.	1	3" Polyolefin

Compatible with Models 37608, 37678, 37688, 37612, 37672, 37682, 37616, 37676, 37686

Industrial-Duty Straight Wall Containers



Our SX Cross Cube containers have a special bottom that allows larger containers to stack on top of smaller containers.



Custom Interior Dunnage
For special product applications, we will analyze your needs and design custom interior packaging to protect your product.



SW12070502



SW15120602



SW151208A2



SW15121002



SW24111002



SW241504A2



SW24150602



SW241508A2



SW24151002



SW241511A2



SW24151502



SW24220802



SW24221102



SW32150802



SW48150802

Straight Wall Containers

Model No.	Outside Dimensions						Capacity	
	Inches			mm			Lbs.	Kg
	L	W	H	L	W	H		
SW12070502	12	7½	5	305	191	127	60	27
SW15120602	15	12	5½	381	305	140	100	45
SW151208A2	15	12	7½	381	305	191	100	45
SX151208A4	15	12	7½	381	305	191	100	45
SW15121002	15	12	9½	381	305	241	100	45
SW24111002	24	11	9½	610	279	241	100	45
SW241504A2	24	15	4	610	381	102	100	45
SX241504A4	24	15	4	610	381	102	100	45
SW24150602	24	15	5½	610	381	140	100	45
SW241508A2	24	15	7½	610	381	191	100	45
SX241508A4	24	15	7½	610	381	191	100	45
SW24151002	24	15	9½	610	381	241	100	45
SX24151000	24	15	9½	610	381	241	100	45
SW241511A2	24	15	11	610	381	279	100	45
SX241511A4	24	15	11	610	381	279	100	45
SW24151502	24	15	14½	610	381	368	100	45
SW24220802	24	22	7½	610	559	191	100	45
SW24221102	24	22	11	610	559	279	100	45
SW32150802	32	15	7½	813	381	191	100	45
SW48150802	48	15	7½	1219	381	191	100	45
SX48150800	48	15	7½	1219	381	191	100	45



Interworking sizes allow mixed stacking on 48" x 40" and 48" x 45" pallets.

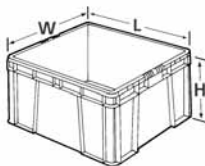

Lids

Model No.	Description	Outside Dimensions				Straight Wall Footprint
		Inches		mm		
		L	W	L	W	
SL12070100	Vacuum Formed	11¾	7¼	298	184	12" x 17"
SL15120100	Injection Molded	15	12	381	305	15" x 12"
SL24150100	Injection Molded	24	15	609½	381	24" x 15"
SL24110100	Injection Molded	24	11¾	609½	285	24" x 11"
SL24220100	Injection Molded	24½	22½	610½	560	24" x 22"

Heavy-Duty Industrial Boxes

Stacking & Nesting Boxes
Saves space at workstations

Hopper Boxes
Features easy front access for picking efficiency

Tote Boxes
Lightweight, stackable, and replaces steel containers

Industrial Totes
For conveyor belts or picking operations



- Ideal for a wide range of applications such as shipping & storage, organizing workstations, and assembly operations.
- HDPE structural foam construction for durability.

Tote Boxes

- Lightweight, stackable, and strong to replace steel containers.
- 4 sizes.
- Vented and solid styles.
- 150 lb. capacity.
- Colors: Black or Blue.



HL21130000

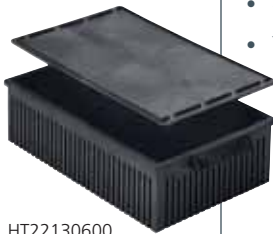

HT22130600

Tote Boxes

Model No.	Outside Dimensions						Capacity	
	Inches			mm			Lbs.	Kg
	L	W	H	L	W	H		
HT15100622	15	10	6	381	254	152	150	68
HT15100600	15	10	6	381	254	152	150	68
HT19100422	19	10	3½	483	254	89	150	68
HT19100400	19	10	3½	483	254	89	150	68
HT22130622	22	13¼	6	559	337	152	150	68
HT22130600	22	13¼	6	559	337	152	150	68
HT16100422	15⅞	10⅝	4⅞	404	258	107	150	68
HL14100000	14	10	¼	35	254	6	-	-
HL21130000	21	13¼	¼	533	337	6	-	-

Hopper Boxes



- Great space savers for shelving and workstations.
- Easy front access for picking efficiency.
- An excellent alternative to steel hoppers.
- Available in 2 sizes, stack 4 high when loaded.
- 150 lb. capacity.
- Colors: Black or Blue (other colors available with a flushout charge).



HH19110700

HH24110900

Hopper Boxes

Model No.	Outside Dimensions						Capacity	
	Inches			mm			Lbs.	Kg
	L	W	H	L	W	H		
HH19110700	19¼	11	6¾	489	279	171	150	68
HH24110900	23½	11	9	597	279	229	150	68

Industrial Tote Trays



- Available in two styles: solid bottom or 1/4" diameter drainage holes.
- Space savers: nestable and stackable.
- Designed for rugged conveyor use or picking operations.
- 100 lb. capacity.
- Color: Black.



Industrial Tote Trays

Model No.	Outside Dimensions						Capacity	
	Inches			mm			Lbs.	Kg
	L	W	H	L	W	H		
HI20140320	20	14	2¾	508	356	70	100	45
HI20140300	20	14	2¾	508	356	70	100	45
HI20140400	20	14	4	508	356	102	100	45
HI20140420	20	14	4	508	356	102	100	45

Stacking & Nesting Boxes

Molded-in ergonomic handles for easy lifting



Nest for space saving in storage

Wide stacking stop for stability

- The boxes stack and nest for transport and workstation space savings.
- Available in 3 sizes.
- 150 lb. capacity.
- Colors: Black or Blue (other colors available with a flushout charge).



Stacking & Nesting Boxes

Model No.	Outside Dimensions						Capacity	
	Inches			mm			Lbs.	Kg
	L	W	H	L	W	H		
HS22130600	22	13	5¾	559	330	141	150	68
HS24160900	24	16	9	610	406	229	150	68
HS28170900	28	16¾	8¾	711	425	222	150	68

Tote Caddy

- Hand-held tool and supply caddy.
- Deep compartments hold loose parts, cleaning supplies, or tools for easy transport.
- Molded of heavy-duty, industrial-grade polypropylene for lasting durability.
- Color: Blue.

Industrial-strength polypropylene

Handle provides comfortable grip even under heavy loads



8" deep compartments are ideal for hardware, automotive items, or cleaning supplies

Tote Caddy

Model No.	Outside Dimensions						Ctn. Qty
	Inches			mm			
	L	W	H	L	W	H	
09185	13¾	18¼	8¾	349	464	222	6

Cross-Stack Akro-Tub

New!



Stacking grooves allow stable 90° stacks

- Industrial-grade 90° nest and stack tub.
- Nesting when empty conserves storage space.
- Molded-in side handles for comfortable lifting.
- Manufactured from FDA-approved materials.
- Smooth surface is easy to clean.
- Compatible with standard 36" shelving and conveyor systems.
- Color: Gray.



Molded-in handles for easy lifting

Extra-thick walls and reinforcing ribs provide superior strength

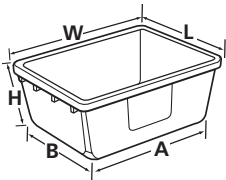

Cross-Stack Akro-Tub

Model No.	Inches						mm					Capacity Gal.	Ctn. Qty.
	L	W	H	A	B	L	W	H	A	B			
34301	17¼	11	8	13¼	7¾	438	279	203	337	196	3.85	6	
34302	17¼	11	12	12⅝	7	438	279	305	319	178	5.51	6	
34303	23¾	17¼	8	19¾	14	603	438	203	502	354	9.81	6	
34304	23¾	17¼	12	19	13¼	603	438	305	484	337	14.38	6	

Akro-Tub & Rack



Akro-Tub Rack holds 6 Akro-Tubs on angle-iron slides for up to 600-lb. total capacity. Welded steel frame with 12-gauge base and bolted-on casters. Color: Gray. Tubs sold separately.

- Heavy-duty, industrial-grade nesting tub.
- Tub manufactured from FDA-approved materials.
- Smooth surface is easy to clean.
- Nests when empty to conserve storage space.
- Use the Akro-Tub Rack (RA6TR4MR) to provide easy loading and transport of multiple Akro-Tubs.
- 75 lb. capacity per tub.
- Color: Gray.



Tubs nest for convenient storage.

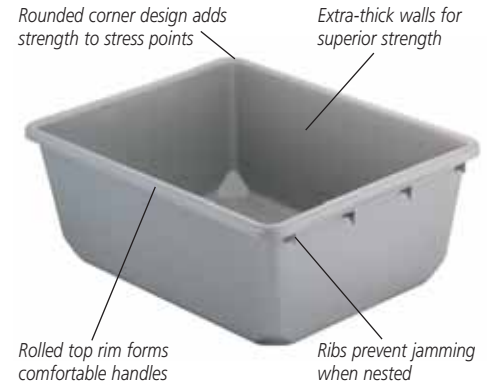

Rounded corner design adds strength to stress points

Extra-thick walls for superior strength

Rolled top rim forms comfortable handles

Ribs prevent jamming when nested

Akro-Tub

Model No.	Inches						mm					Ctn. Qty.
	L	W	H	A	B	L	W	H	A	B		
34240	19	24½	9½	20½	15½	483	622	241	521	394	6	

Order in carton quantities.

Akro-Tub Rack

Model No.	Inches				mm			Casters
	H	W	D	H	W	D		
RA6TR4MR*	73	24	24	1854	609	609	4" x 2" Moldon Rubber – 2 Rigid, 2 Swivel	

*Tubs sold separately.

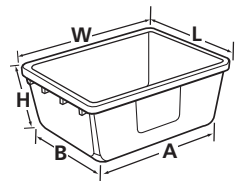

Agricultural Containers

- Easy-to-clean containers are durable and reusable to save money for growers, packers, shippers, and retailers.
- Stack when full, nest when empty for space efficiency.
- Ventilated designs for quick cooling, temperature control, and drainage.

Harvesting Containers

- Suitable for mushrooms, grapes, asparagus, and other small fruits and vegetables.
- Stacking posts permit rigid stacking with a 180° turn.
- Nesting ratio of 2.6:1 to save storage space and shipping costs.
- Color: Gray.



AG24160752

Model No.	Inches			mm			Capacity	
	L	W	H	L	W	H	Lbs.	Kg
AG24160752	24	16½	7¼	610	410	185	60	27

Produce Lugs

- Perfect harvesting and shipping tray for mushrooms or other small products.
- Locking pegs limit container movement to prevent product damage during transport.
- Capable of holding 8, 12, and 16 oz cartons or loose product.
- Produce Lugs stack and nest with either a 180° or 90° turn.
- Color: Gray.



AG20160422

Model No.	Inches			mm			Capacity	
	L	W	H	L	W	H	Lbs.	Kg
AG20160422	19½	16¾	4¾	495	415	105	10	5

Specialty Containers

Commissary Case

- Open-weave design for efficient cooling to keep food fresh.
- Lengthwise zinc-plated steel bails fold in for secure stacking and out for space-saving nesting.
- Cases fit six per layer on a 48" x 40" pallet.
- Color: Beige.

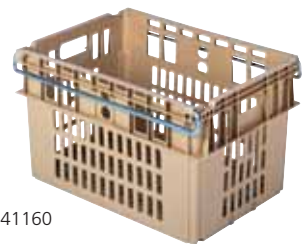

CC20141160

Commissary Case

Model No.	Inches			mm			Capacity	
	L	W	H	L	W	H	Lbs.	Kg
CC20141160	20	14¾	11	510	365	280	60	27

JumboLugs

- Stacking grooves allow rigid 90° stacks.
- Fits standard cart and rack sizes.
- Compatible with most conveyor systems.
- Optional Lid: Model No. LJ25160200 (Lid)
- Available in Natural, Gray, Yellow, Red, Green



JL25160968

Jumbo Lugs

Model No.	Inches			mm			Capacity	
	L	W	H	L	W	H	Lbs.	Kg
JL25160968	25	16	8½	635	405	215	100	45
LJ25160200	25¾	16¾	1¾	645	418	40	-	-

Food Processing Containers

- Designed to fit a wide range of shipping, handling, and storage applications for food processors, distributors, and retailers.
- All products molded from approved materials and designs.
- Resist temperature extremes (-20°F to 120°F).

NestPac Containers



NP24160887

Lid
NL24160259



NP24161195

- Ideal for poultry, meat, and seafood processing, distribution, and many other foodservice and grocery applications.
- Containers stack with lids, cross-stacking 5 per layer on a 48" x 40" pallet.
- Nest when empty for space-saving storage and return shipment.
- Smooth interiors for easy cleaning.
- Available with drain holes.
- Colors: Blue, Gray, Beige.



NestPac containers allow sanitary handling during distribution.



NestPac Containers

Model No.	Outside Dimensions						Capacity		Drain Holes
	Inches			mm			Lbs.	Kg	
	L	W	H	L	W	H			
C18-541E	24 ⁵ / ₁₆	16 ⁵ / ₁₆	8 ³ / ₄	620	415	222	50	23	No
NP24160887	24 ⁵ / ₁₆	16 ⁵ / ₁₆	8	620	415	205	50	23	Yes
NP24161194	24 ⁵ / ₁₆	16 ⁵ / ₁₆	10 ¹³ / ₁₆	620	415	275	80	36	No
NP24161195	24 ⁵ / ₁₆	16 ⁵ / ₁₆	10 ¹³ / ₁₆	620	415	275	80	36	Yes
NL24160259 Lid	24 ³ / ₈	16 ³ / ₈	1 ¹³ / ₁₆	620	415	45	-	-	-



Aluminum dolly provides easy transport of full ChillPac Containers with bails. 1800 lb. capacity. Model No. DY22190700

ChillPac Container System

- Available in 7", 10", and 13" interworking heights.
- Molded-in handles for easy lifting.
- 24" x 20" footprint cubes standard food industry pallets.
- Suitable for in-store display use.
- Compatible with most automated systems.
- Colors: Blue, Beige.

Pivoting zinc-plated bails swing in for stacking and out for nesting

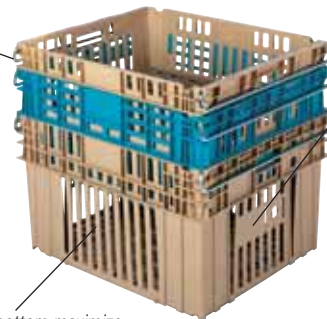

Label areas allow easy identification of containers and contents

Ventilated sides/bottom maximize airflow to maintain uniform coolness

ChillPac Container System

Model No.	Outside Dimensions						Capacity	
	Inches			mm			Lbs.	Kg
	L	W	H	L	W	H		
CP24200760	24	20	6 ⁷ / ₈	610	508	175	60	27
CP24201360	24	20	13 ³ / ₈	610	508	340	100	45
CP24201060	24	20	9 ⁹ / ₁₆	610	508	243	80	36
DY22190700 Dolly	22 ³ / ₈	18 ⁷ / ₈	8	568	479	203	1800	810



CP24200760



CP24201060

ChillTrays

- Open weave design allows quick chilling/cooling of meat, poultry, or seafood for in-plant handling and distribution.
- Reinforced sides and bottoms prevent flexing under loads.
- Reinforced design for weight loads of 40+ lbs.
- Smooth surfaces are easy to clean.
- Color: Beige.



CT29260922

Shelf Divider
CD28260120

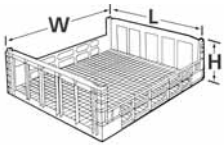
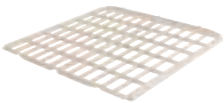

Reinforced corner ribs provide strength for secure stacking



Open-weave bottom and open sides maximize ventilation for efficient cooling

Trays stack and cross nest for space efficiency

ChillTrays

Model No.	Outside Dimensions						Capacity	
	Inches			mm			Lbs.	Kg
	L	W	H	L	W	H		
CT29260922	29 1/8	26 1/16	9	70	662	229	80	36
CD28270120	27 1/2	26 1/16	1 1/8	669	662	33	40	18

MultiPac™ Container

- Three-level design for efficient distribution of steaks, chubs, and chops.
- Nesting design saves freight and storage costs; 180° turnaround provides a 2" high internal product height.
- Molded-in stacking posts create a secure 4.2" high internal product level.
- 24" x 20" x 6.7" size optimizes internal space usage.
- Cubes 48" x 40" pallets for transport efficiency, lower costs.
- Colors: Blue/Gray.



Lengthwise bails fold in to prevent product damage.

Ergonomic handles for easy lifting and safe handling versus cardboard

Bi-Color design for quick identification of stack and nest positions

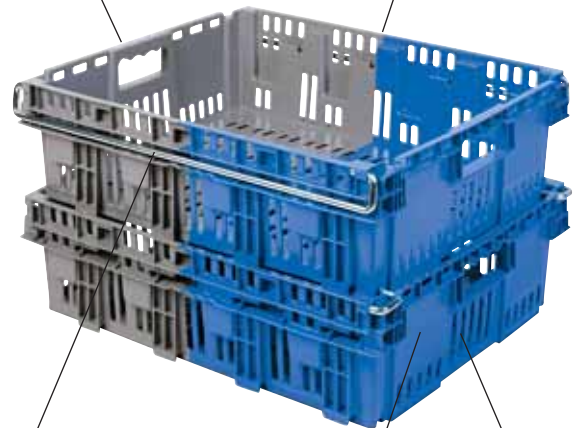

Metal bails on the long side provide secure stacking, product protection, and a 5.9" internal product level

Large label areas for easy identification of container and contents

Ventilated design allows uniform cooling

MultiPac™ Container

Model No.	Outside Dimensions						Capacity	
	Inches			mm			Lbs.	Kg
	L	W	H	L	W	H		
MP24200722	24	20	6 1/16	610	508	170	30	13.6

Bulk Boxes



Bulk Boxes are easy to collapse and stack securely, loaded or folded, to save freight and storage costs

- Manufactured from HDPE structural foam plastic for strength and long service.
- Durability for hundreds of round trips with low cost per-trip.
- Backed by a 3-year warranty.

Post & pocket panels or snap-lock latches for smooth collapse and set-up

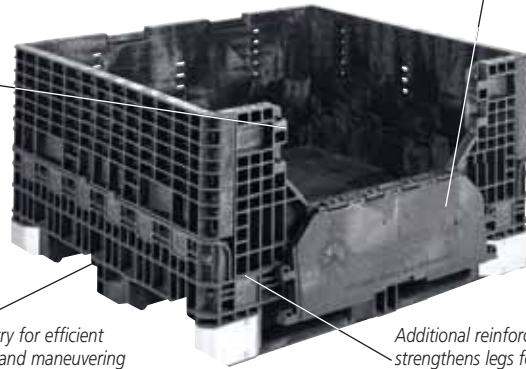

Drop doors allow quick, easy access to contents

Four-way forklift entry for efficient loading, unloading, and maneuvering in trailers and storage areas

Additional reinforced ribbing strengthens legs for maximum durability and even weight distribution

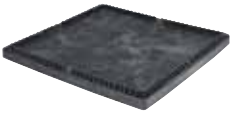

Structural foam lids provide heavy-duty strength and prevent contamination. Available on select Bulk Boxes.

Heavy-Duty Bulk Box

- The Heavy-Duty line is structural foam molded and will support loads up to 2,500 lbs.
- Reinforced base with 3 steel runners for durability.
- Interlocking side panels form continuous reinforcing ribs for strength.
- 4-way fork entry for easy handling.
- Colors: Black, Blue, and Lt. Gray.

Drop doors allow easy access to product: 0, 1, or 2 door options



BH48403420

Steel corner hit plates deflect fork tines and extend box life

Heavy-Duty Bulk Boxes

Model No.	Dimensions						Capacity	
	Inches			mm			Lbs.	Kg
	L	W	H	L	W	H		
BH48403420	47 ⁵ / ₈	39 ³ / ₄	33 ⁷ / ₈	1210	1010	860	2500	1134
BH48453420	47 ⁵ / ₈	44 ⁵ / ₈	34	1210	1133	864	2500	1134
Lids								
TH484002001	48 ³ / ₈	40 ⁷ / ₁₆	2 ¹ / ₈	1229	1027	54	-	-
TH484502001	48 ¹ / ₄	45 ¹ / ₄	2 ¹ / ₄	1226	1149	57	-	-

Lid



TH484002001

Extended Length Bulk Box

- Extended length holds extra-large, extra-long parts.
- Unique, reinforced design delivers secure, rigid stacking.
- Solid, one-piece base for handling any load up to 2,000 lbs.
- Long side walls collapse first to prevent wall bowing in storage.
- Color: Black.

Extra-long drop doors provide quick, easy access to contents



BS64483411

Spring-loaded latches ease assembly and knock-down

Optional steel hit plates deflect fork tines to prevent spearing

Extended Length Bulk Boxes

Model No.	Dimensions						Capacity	
	Inches			mm			Lbs.	Kg
	L	W	H	L	W	H		
BS64483411	64 ¹ / ₂	48	34	1638	1219	864	2000	907

Industry Standard Bulk Box

- Industry Standard Bulk Boxes are perfect for many manufacturing applications, providing superior product protection for loads up to 1,800 lbs.
- 2 drop doors for quick access.
- Interlocking side panels form continuous reinforcing ribs for strength.
- Structural foam construction gives long service life.
- Optional lids protect contents from debris.
- Colors: Black, Blue.

Snap-lock latches for easy set-up or knock-down

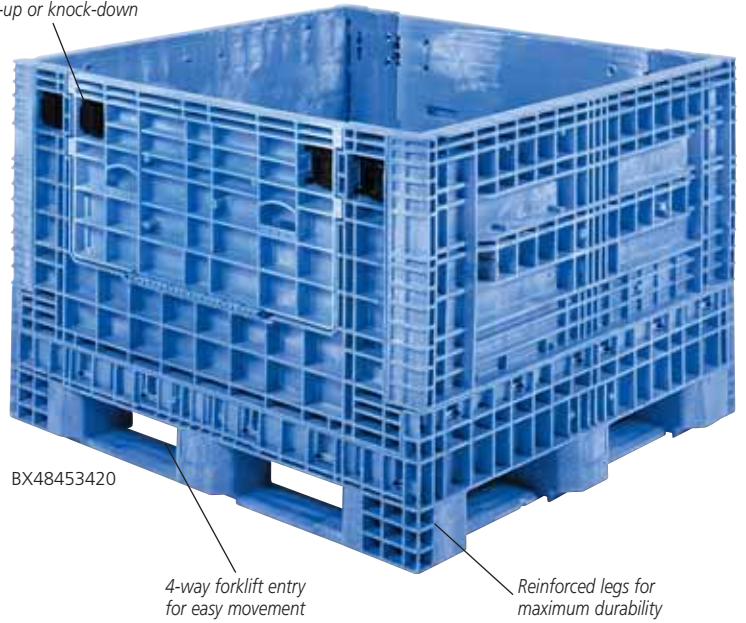

BX48453420

4-way forklift entry for easy movement

Reinforced legs for maximum durability

Industry Standard Bulk Boxes

Model No.	Outside Dimensions						Capacity	
	Inches			mm			Lbs.	Kg
	L	W	H	L	W	H		
B532302500	32	30	25	816	762	635	1800	817
B532303420	32	30	34	816	762	864	1800	817
BX48453420	48	45	34	1219	1143	864	1800	817
Lids								
TS32300200	32 ³ / ₄	30 ³ / ₄	2 ¹ / ₂	832	781	64	-	-
TS48450300	49	46	2	1245	1168	51	-	-

Lid



TS32300200

General Purpose Bulk Box

- A perfect choice for lighter-weight material handling. General Purpose Bulk Boxes can be used in applications from agriculture and general manufacturing to plastic parts transport.
- Redesigned base and walls provide an increased capacity to 1,500 lbs.
- 4-way fork lift entry for easy movement.
- Side latches secure panels and doors.
- Optional lid to protect contents from debris.
- Color: Gray.

Extra-deep drop door allows easy access to contents



BG48403302

Snap-lock latches for easy assembly and knock-down

General Purpose Bulk Boxes

Model No.	Outside Dimensions						Capacity	
	Inches			mm			Lbs.	Kg
	L	W	H	L	W	H		
BG48403302	48	40	34	1219	1016	864	1500	680
Lid								
TS48400200	49	41 ³ / ₂	2	1245	1044	51	-	-

Lid



TS48400200

Pallets

- Reusable for hundreds of round trips and lower overall cost per-trip.
- Lightweight design for safer handling.
- Compatible with automated handling equipment.
- Superior resistance to moisture, most chemicals, and temperature extremes.
- 100% recyclable for environmental and cost savings.

Exceptional strength to withstand heavy loads and high impact

Nestable or stackable for storage space savings

4-way entry for efficient handling by forklifts and pallet jacks

HDPE construction never rots or splinters

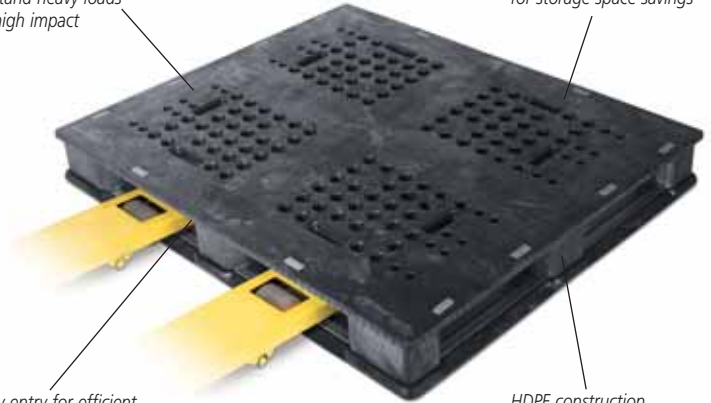

Medium-Duty Nestable Pallet

- Available in 48" x 40" and 48" x 48" footprints.
- 4,000 lbs. dynamic load capacity.
- 9 reinforced feet uniformly distribute the load.
- Available with solid deck.



PM484006001

Medium-Duty Nestable Pallet

Model No.	Inches		Dimensions				Capacity	
	L	W	H	L	W	H	Lbs.	Kg
PM484006001	48	40	6	1219	1016	152	4000	1800
PM484806001	48	48	6	1219	1219	152	4000	1800



Medium-Duty Rackable Pallet

- Available in 48" x 40" and 48" x 48" footprints.
- 4,000 lbs. dynamic load capacity.
- 6 rails on base for safe racking.
- Available with solid deck.



PM484006331

Medium-Duty Rackable Pallet

Model No.	Inches		Dimensions				Capacity	
	L	W	H	L	W	H	Lbs.	Kg
PM484006331	48	40	6¼	1219	1016	159	4000	1800
PM484806331	48	48	6¼	1219	1219	159	4000	1800



Standard Nestable Pallet

- Available in 48" x 40" footprint.
- 2,000 lbs. dynamic load capacity.
- 9 reinforced feet uniformly distribute the load.
- Available with ventilated deck.
- 4-way entry accommodates fork trucks and pallet jacks.
- Lightweight design - 29 lbs. for easy lifting.



PS484006001

Standard Nestable Pallet

Model No.	Dimensions						Capacity	
	Inches			mm			Lbs.	Kg
	L	W	H	L	W	H		
PS484006001	48½	40½	6¼	1233	1030	159	2000	900



Standard Stackable Pallet

- Available in 48" x 40" footprint.
- 1,500 lbs. dynamic load capacity.
- Rackable with center support or decking with 9-post construction for strength.
- 2-piece, snap together design allows components to be replaced without purchasing a new pallet.
- Solid deck with textured, anti-skid surface.
- 4-way entry accommodates fork trucks and pallet jacks.



PS484006331

Standard Stackable Pallet

Model No.	Dimensions						Capacity	
	Inches			mm			Lbs.	Kg
	L	W	H	L	W	H		
PS484006331	48	40	5½	1219	1016	141	1500	680



Heavy-Duty Universal Pallet

- Edge rackable to 2,800 lbs. - choose from molded-in plastic or steel reinforcement rods to match your capacity requirements.
- Available in 48" x 40" footprint.
- Angled 4-way entry points guide fork tines for easy handling.

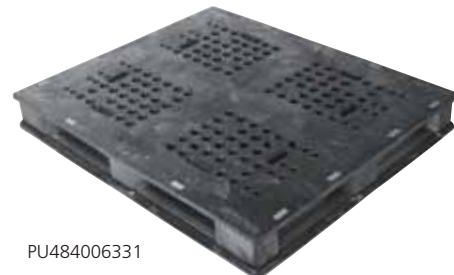

PU484006331

Heavy-Duty Universal Pallet

Model No.	Dimensions						Capacity	
	Inches			mm			Lbs.	Kg
	L	W	H	L	W	H		
PU484006331	48	40	5½	1219	1016	141	5000	2268







38
Recycling Containers
Fits office or home recycling programs.



39
MegaKart
Economical container for mobile waste transport.



39
BossKart
Exceptionally durable and strong mobile waste container.



40
Akro-Carts
Non-tipping carts for waste collection, transport, and disposal.



40
Whisper Series
Exceptionally quiet waste handling container.



41
Akro-Tilt Trucks
Lightweight tipping trucks for heavyweight jobs.



41
Akro/Lift
Clean, efficient, and safe dumping system.



42
Janitor Cart
Smart features designed to help work faster and more efficiently.



43
Compact Cleaning Cart
Revolutionary cleaning cart to save time.

Recycling & Waste Transport Systems

Recycling Containers

- Variety of sizes simplifies separation of glass, paper, and plastic for sorting or pickup.
- Durable plastic construction with a UV inhibitor to resist fading.
- Withstands a wide temperature range -20° F to 120° F.
- Containers are imprinted with “WE RECYCLE” to increase program awareness.
- Color: Blue.



C75-605



075-611



RC25171401



BX48453420



TS48450300

Recycling Containers

Model No.	Outside Dimensions						Capacity	
	Inches			mm			cu. ft.	liters
	L	W	H	L	W	H		
C75-605	16 ¹ / ₁₆	16 ¹ / ₁₆	8 ³ / ₁₆	408	408	208	.9	25.5
075-611	20 ³ / ₄	15	12	527	381	305	1.69	48
RC25171401	25	17	13	635	432	330	2.54	72
Bulk Box							lbs.	Kg
BX48452520	48	45	25	1219	1143	635	1800	810
BX48453420	48	45	34	1219	1143	804	1800	810
Bulk Box Lid								
TS48450300	48 ³ / ₄	45 ¹ / ₄	2 ³ / ₄	1238	1149	70	-	-

MegaKart®



Patented design allows carts to nest with installed lids and latchbars for compact shipping and storage



Foot Tilt Pocket molded above axle for maximum leverage and utility



Option: Lids can be ordered with patented latch feature to restrict full opening to 110 degrees.

- 65 and 96-Gallon carts designed for residential waste management.
- Compatible with automated and semi-automated systems.
- Attached lid swings out of the way for easy dumping.
- Injection molded for exceptional durability and cost effectiveness.
- Can be stacked and transported with factory-installed lids and latch bars.
- Resists damage from oil and most chemicals, engineered for rigidity and strength.
- All carts are compatible with Hydraulic Akro/Lift (page 41).
- Colors: Dark Green, Dark Blue, Light Gray.

Molded-in ergonomic handles for ease of handling



Domed lid repels water and allows over-packing

Textured corners have non-slip, non-marring surfaces for automated lift systems

1" tubular latch bar for use with semi-automated lift systems

HDPE snap-on style wheels

Scuff rails molded in the base for added durability

MegaKart®

Model No.	Capacity Gallons	W	Inches D	H	W	mm D	H	Wheel Dia.	Load Rating	Ship Wt.
79596	96	28	32	46	711	813	1168	12"	335 lbs.	43 lbs.
79565	65	26	27	42	660	686	1067	10"	230 lbs.	35 lbs.

Please specify color when ordering.

BossKart® & Versa-Kart®



Ergonomic Handles: Molded as part of container body. Lid handle for easy access.



Scuff Rails: Molded in the base for added durability. Expanded footprint for stability.



Foot Tilt: Easy access to axle for maximum leverage and utility.

- 65 and 96-Gallon carts designed for residential waste management.
- Compatible with automated and semi-automated systems.
- Attached lid swings out of the way for easy dumping.
- Rotationally molded for uniformly thick, seamless walls with stress-free corners.
- Features a unique corner shape and pleats for exceptional strength.
- All carts are compatible with Hydraulic Akro/Lift (page 41).
- Colors: Dark Green, Dark Blue, Light Gray.

Domed lid repels water and allows over-packing

1" tubular latch bar for use with semi-automated lift systems

Attached lid's convex shape allows over-loading and prevents water pooling

Plated steel axle resists corrosion. 35-gallon: 5/8" OD, 60 & 90-gallon: 3/4" OD



HDPE snap-on style wheels

Reinforced lift points - Design distributes weight evenly during lift cycle

Steel latch bar for use with semi-automatic lift systems

12" diameter wheels are molded from recycled, post-consumer plastic (8" diameter on the 35-gallon model)

BossKart®

Model No.	Capacity Gallons	W	Inches D	H	W	mm D	H	Wheel Dia.	Load Rating	Ship Wt.
79496	96	29	36	46	737	914	1168	12"	335 lbs.	42 lbs.
79465	65	28	33	41	711	838	1041	10"	230 lbs.	34 lbs.

Please specify color when ordering.

Versa-Kart®

Model No. Green*	Model No. Blue*	Model No. Gray*	Capacity Gallons	W	Inches D	H	W	mm D	H	Load Rating	Approx. Ship Wt.
V2124VK3518	V2119VK3518	V2118VK3518	35	22¼	23	37½	565	584	902	120 lbs.	23 lbs.

*Black lid is standard with all models.

Akro-Carts



Frame is made from 16-gauge zinc-plated steel tubing on medium-duty models and powder-coated steel on heavy-duty models.

- Make transport and disposal within a facility fast, safe, and clean.
- Medium-duty and heavy-duty styles to fit your needs.
- Latch bars extend around the frame for added strength.
- Wide mouth and low profile for easy loading.
- Medium-duty carts have riveted joints.
- Heavy-duty cart has welded joints.
- All carts are compatible with Hydraulic Akro/Lift (page 41).
- All carts available in Gray (Black Lid), Blue (Blue Lid) and Green (Green Lid).



Convex shape lid for strength and overpacking

Front caster balances the load making the cart easy to push or pull



Heavy-duty piano hinge keeps lid propped open during use.



Akro-Cart 90
Medium-Duty
76490



Akro-Cart 60
Medium-Duty
76460



Akro-Cart 90
Heavy-Duty
76591

Wheels and Axles: Medium-duty 60 and 90 gal. Akro-Carts feature 12" dia. wheels, high-impact plastic hubs with semi-pneumatic tires and 16-gauge steel tubing axle.

Wheels and Axles: Heavy-duty 90 gal. features 3/8" dia. solid steel shaft axle.

Akro-Carts

Model No. Without Lid*	Model No. With Lid	Description	Inches			mm			Load Rating	Approx. Ship Wt.
			W	D	H	W	D	H		
76460	76461	Medium-Duty 60 Gal. Cap.	30½	48	33½	775	1219	851	300 lbs./136 kg.	51 lbs./23 kg. (w/lid)
76490	76491	Medium-Duty 90 Gal. Cap.	30½	47	39½	775	1194	1003	350 lbs./159 kg.	56 lbs./25 kg. (w/lid)
76590	76591	Heavy-Duty 90 Gal. Cap.	30½	47	39½	775	1194	1003	450 lbs./204 kg.	71 lbs./32 kg. (w/lid)

Please specify colors when ordering.

*Carts without lids cannot have lids added after production. Single units are shipped completely assembled.

When multiple units are ordered, lids are shipped separately and require assembly.

Whisper Series



Lift pockets and casters mounted with stainless steel fasteners

- 3/8" thick roto-molded LLDPE walls are impact and dent resistant. UV resistant to prevent damage from sunlight.
- Molded LLDPE pocket liners for durability and noise reduction.
- Lid ribbed for strength and rapid water deflection.
- Smooth, reinforced corners and sidewalls are easy to clean.
- Molded-in color will not chip or peel. Resists damage from harsh chemicals and petroleum based liquids.



Lift pockets are formed from 10-gauge solid steel plates with a black powder-coated finish to resist rust



6" solid rubber casters



Caster assembly is 7-gauge solid steel. Mounting bolts are molded in base

Whisper Series

Model No.	Size	Ht. Front	Inches			mm				Ship Wt.
			Ht. Back	Length	Depth	Ht. Front	Ht. Back	Length	Depth	
ACR-2	2-yard	38¾"	46"	71¾"	34⅞"	975	1168	1822	886	290 lbs.
ACR-3	3-yard	44½"	55⅞"	71¾"	40⅞"	1130	1405	1822	1038	390 lbs.
ACR-4	4-yard	51"	63"	71¾"	47"	1295	1600	1822	1194	420 lbs.
ACR-6	6-yard	51"	68"	71¾"	70¾"	1295	1727	1822	1747	460 lbs.

Akro-Tilt Trucks



Trucks tip for easy manual emptying.



Full, wrap-around tubular frame is 1" treated steel reinforced with 3/4" pipe insert.

- Lightweight tipping trucks for heavy-weight jobs (up to 2000 lbs.).
- Ergonomic design makes trucks easy to maneuver.
- Caster wheel has roller bearings for extra stability when pushing, pulling, or turning.
- Handle is arc welded and reinforced for optimum durability.
- Wrap-around tubular frame is constructed of 1" powder-coated steel for enhanced appearance & rust protection.
- Designed for use with Hydraulic Akro/Lift (See below).
- All trucks available in: Gray, Red, Yellow, or Blue.

Wide mouth and low profile for easy loading



10" dia. wheels. Medium-duty trucks have 12" dia. wheels

Easy-pull, load-balanced design provides stability



77405
Medium-Duty
100 gal.



77505
Heavy-Duty
100 gal.



77610
Super Heavy-Duty with optional lid
200 gal.

Akro-Tilt Trucks

Model No.	Description	Inches			mm			Wheel Dia.	Capacity		Load Rating	Ship Wt.
		W	D	H	W	D	H		Gallons	Cu. Yds.		
77405	Medium-Duty 100	27	54	36	686	1372	914	12"	100	1/2	600 lbs./272 kg.	94 lbs./43 kg.
77410	Medium-Duty 200	33	66	42	838	1676	1067	12"	200	1	600 lbs./272 kg.	137 lbs./62 kg.
77505	Heavy-Duty 100	27	54	36	686	1372	914	10"	100	1/2	1000 lbs./454 kg.	115 lbs./53 kg.
77510	Heavy-Duty 200	33	66	42	838	1676	1067	10"	200	1	1000 lbs./454 kg.	150 lbs./58 kg.
77610	Super Heavy-Duty 200	33	66	42	838	1676	1067	12"	200	1	2000 lbs./907 kg.	170 lbs./77 kg.



Optional Akro-Lid

Convex shape adds strength and provides room for overpacking. Available only for Medium-Duty 200, Heavy-Duty 200, and Super Heavy-Duty 200 (color: Black). A full-width, heavy-duty piano hinge in the middle keeps the lid propped open during use and allows front and back access.

Optional Lid For Akro-Tilt Trucks

Model No.	Description	Inches			mm			Fits Akro-Tilt Truck Model	Ship Wt.
		W	D	H	W	D	H		
77002	Black Lid	34	67	5	864	1702	127	77410, 77510, 77610	12 lbs./5 kg.

Akro/Lift



Clean, efficient, and safe emptying of Akro-Carts, Versa-Karts, and Akro-Tilt Trucks.

- Empties into containers, bailers, or compactors up to 57" high.
- Cylinder mounts and main hinge are reinforced with 3/4" steel.
- All moving parts are enclosed for worker safety.
- Weather-proof, hand-held remote control is standard.
- 12-Volt DC battery or specify voltage: 1-phase: 110, 220; 3-phase: 220, 230, 460, 575 (Canada).
- Standard finish is gray enamel. Custom colors available.



Easy detachment casters allow lift to be relocated

Hydraulic Akro/Lift

Model No.	Description	Inches			mm			Akro-Cart Clearance			Tilt-Truck Clearance			Versa-Kart Clearance			Capacity	Ship Wt.
		W	D	H	W	D	H	R"	V"	H"	R"	V"	H"	R"	V"	H"		
78100	Hydraulic Akro/Lift	42 1/2	45	47	1080	1143	1194	115	93	115	132	93	132	109	90	109	1000 lbs./454 kg.	700lbs./317 kg.

Installation video available upon request. R = Swing Radius, V = Vertical Clearance, H = Horizontal Clearance.

AkroClean™ Janitor Cart



The AkroClean Janitor Cart is designed to hold more supplies, keep trash concealed, separate wet and dry zones, and support a full mop bucket for easy transport. Add the sleek design, no-tip stability, and removable front platform, and you have one very effective cleaning, hauling, supply-storing cart.

The inside shelf has three adjustable positions within the central compartment. Order a second shelf to extend your storage options. (Cart shown with door removed).



The compartment door is easily removable for cleaning and open access to shelves.



The rear middle shelf is removable without tools.



The door latch fits standard security locks to create a locking storage cabinet.



Lift the lid and release the anchor strap to remove the liner.

Molded with high-density copolymer, AkroClean is strong and easy to clean

Center trash compartment acts as a barrier between wet and dry storage areas

- Fits standard, 32-gallon liner.
- 75-lb. capacity.

Utility hooks hold dust pans, brushes, or towels, and swing back into the handle when not in use



Door conceals unsightly trash

Nickel-plated handle provides a clean surface for a grip clear of the trash area.

Inside dimensions
31½"H x 15¾"W x 15"D

Quick access to supplies from rear shelf

Four, 4" non-marking casters are easy to remove and replace

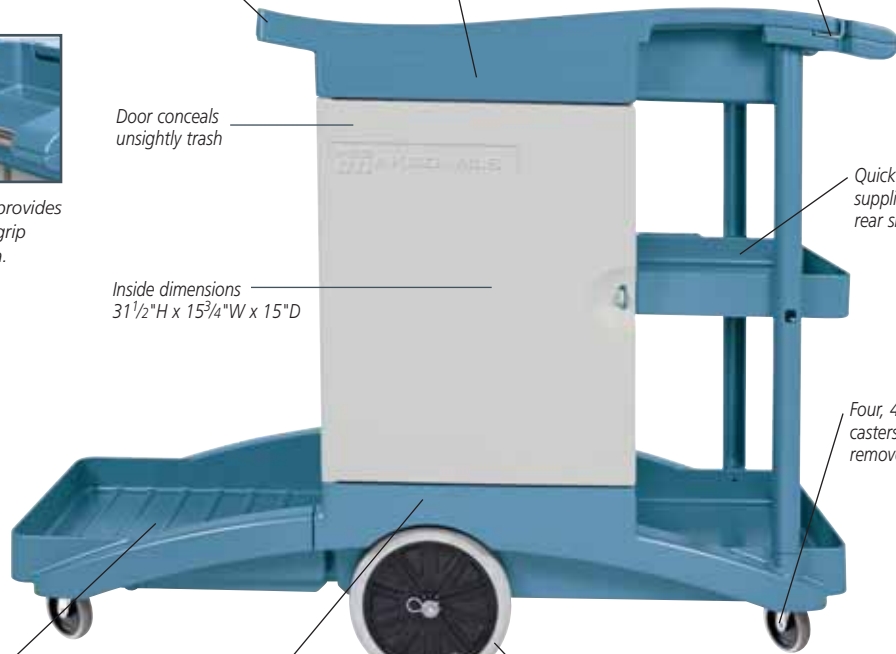

The front platform holds a mop bucket or 32-gallon container, and removes to create a smaller cart

The heaviest part of the cart is centered directly over the wheels for added stability

10" high-density rubber wheels on a steel axle provide quiet, easy maneuverability

AkroClean™ Janitor Cart Ordering Information and Specifications:**

Dimensions:	55"L x 23½"W x 42"H (1397 x 597 x 1067mm)
Cart w/o Front Platform:	40"L x 23½"W x 42"H (1016 x 597 x 1067mm)
Material:	Structural Web Plastic
Wheels:	Two, 10" dia. high-density rubber wheels; four, 4" casters
Model Number:	30955BRGRY – Ice Burgundy ■ 30955BLGRY – Ice Slate ■
Additional Interior Shelf*:	Model No. 30955SHELF (order separately)

* One interior shelf included with AkroClean Janitor Cart.

**Assembly required.

AkroClean™ Compact Cleaning Cart

AkroClean
COMPACT CLEANING CART



Ideal for use in any application:

- Office
 - Hospital
 - Schools & Universities
 - Theaters
 - Hotel
 - Shopping Center
 - Convention Center
- And Many More

The AkroClean Compact Cleaning Cart combines smart features to improve your cleaning efficiency.

- The only cleaning cart in the industry with a molded-in vacuum storage area.
- Zippered, vinyl refuse bag conceals trash.
- Front platform securely holds a mop bucket or a 32-gallon refuse container.
- Ideal for office use, the cart's compact size and contoured design makes it highly maneuverable in tight spaces, avoiding damage to walls and furnishings.

Experience a revolution in your cleaning productivity with the AkroClean Compact Cleaning Cart!

Transports a vacuum, mop bucket or 32-gallon refuse container, and supplies – all in one trip, boosting your cleaning efficiency.



Contoured design allows easy movement in tight areas and helps prevent damage to walls; elegant look blends into any environment

Handle slot secures mop handles in an upright position – protecting walls and people as the cart moves

Handles are spaced away from trash area for more sanitary handling

Deep, molded-in pockets and handle slots store cleaning supplies, brooms, dusters, spray bottles, and more

Molded utility hooks hold dustpans, brushes, or towels

Textured front platform securely holds a mop bucket or a 32-gallon refuse container

Easy-to-remove, zippered, vinyl refuse bag conceals trash or will hold a plastic trash liner

Molded-in area for easy vacuum cleaner transport – an Akro-Mils exclusive!

Moisture dam separates wet and dry areas – protecting cleaning supplies and vacuum

8" fixed and 3" swivel, high-density rubber wheels make maneuvering easy; wheels are non-marking and provide a quiet ride

Plate-style casters bolt on for easy replacement

AkroClean™ Compact Cleaning Cart Ordering Information and Specifications:

Dimensions:	40 ³ / ₁₆ " L x 23" W x 39" H
Material:	Structural Web Plastic
Wheels:	Two 8" non-marking, high-density rubber wheels; Two 3" non-marking, plate-style swivel casters
Model Number:	30945 Gray



Small Parts Storage



46
Steel Cabinets
Industrial-strength small parts storage.



48
Storage Cases
The perfect case for storing and organizing supplies.



46
Mobile Rack
Hangs Akro-Mils steel cabinets for mobile small parts storage.



49
Tilt & Locks
Versatile small parts organizer with tilt-out, locking storage bins.



46
Storage-Go-Round
Rotating system for efficient small parts storage.



48
Tool Boxes
Tough-looking hard-working toolboxes for home or office.



49
Akro/Logic™ Organizers
Compartmentalized storage case with removable bins.



47
Plastic Cabinets
Economical cabinets store, consolidate, and organize small parts.



48
Tool Rack
Organize wrenches, screwdrivers, pliers and other long-handled tools.



49
Roto-Shelf
Move parts between workstations with this mobile storage unit.



47
Portable Organizers
Compartmentalized case for organized, portable parts storage.



48
Wrench Holder
Easy, organized access to up to 15 wrenches by size.

Small Parts Storage

Steel Storage Cabinets



Steel cabinets stack together for high-density storage.

- Store, consolidate, and organize small parts.
- Two cabinets fit side by side on standard 36" wide shelving.
- Drawers are removable and are rust, corrosion, and dent-proof.
- No sharp edges to damage parts.
- Unique rear stop tab on each drawer prevents spills.
- Additional dividers, labels, and replacement drawers can be purchased separately.
- Color: Gray.

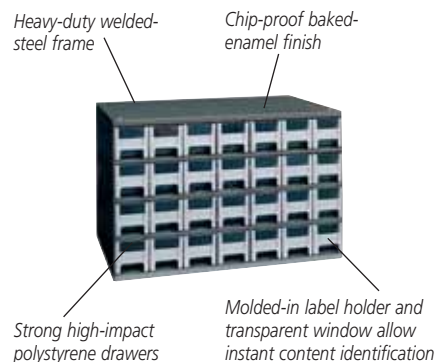

19-Series Heavy-Duty Cabinets

Cabinet frame: 17" wide x 11" deep x 11" high with 10⁹/₁₆" drawer depth. Steel cabinets have five different drawer sizes. Each drawer includes two removable dividers and one label. Seven divider slots per drawer. Optional security cabinet with locking door.



19228



19320



19416



19715



19909



19109

17-Series Light-Duty Cabinets

Cabinet frames: 18" wide x 6" deep x 9¹/₂" high with 5³/₄" drawer depth.



17018



17136

Two Drawer Depths



17-Series have 5³/₄" deep drawers. 19-Series have extra-deep 10⁹/₁₆" drawers for optimum storage flexibility.

Steel Storage Cabinets

Model No.	Description	Drawers Per Cabinet	Drawer Dimensions						Ctn. Qty.	Drawer Model No.	Dividers 25/Pkg. Model No.
			Inches			mm					
			W	H	D	W	H	D			
19-Series Heavy-Duty 17" W x 11" D x 11" H (432 x 279 x 279mm)											
19228	Storage Cabinet*	28	2 ³ / ₁₆	2 ¹ / ₁₆	10 ⁹ / ₁₆	56	52	268	1	20228	40228
19320	Storage Cabinet*	20	3 ³ / ₁₆	2 ¹ / ₁₆	10 ⁹ / ₁₆	81	52	268	1	20320	40320
19416	Storage Cabinet*	16	4	2 ¹ / ₁₆	10 ⁹ / ₁₆	102	54	268	1	20416	40416
19715	Storage Cabinet*	15	3 ³ / ₁₆	3 ¹ / ₁₆	10 ⁹ / ₁₆	81	78	268	1	20715	40715
19909	Storage Cabinet*	9	5 ³ / ₁₆	3 ¹ / ₁₆	10 ⁹ / ₁₆	132	78	268	1	20909	40909
19109	Security Cabinet w/ locking door	9	5 ³ / ₁₆	3 ¹ / ₁₆	10 ⁹ / ₁₆	132	78	268	1	20909	40909
17-Series Light-Duty 18" W x 6" D x 9¹/₂" H (457 x 152 x 241mm)											
17018	Storage Cabinet	18	2 ³ / ₄	2 ¹ / ₂	5 ³ / ₄	70	64	146	1	20902	40901
17136	Storage Cabinet	36	2 ³ / ₄	1 ¹ / ₄	5 ³ / ₄	70	32	146	1	20502	40501

*Available with a locking door when ordered in quantities of 50 or more.

Storage Cabinet Hanging Systems

Mobile Steel Cabinet Rack*

Double-sided, mobile rail rack holds 12 of the 19-Series cabinets with as many as 336 drawers. Supports up to 500 lbs.

Order These Components and Quantities

- 30012 Double-Sided Rail Rack – Qty: 1
- 30424 Mobile Kit – Qty: 1
- 19-Series Cabinets – Mix or Match – Qty: 12
- 98400 Suspension Straps (Set of 2 straps) – Qty: 12 Sets

*Assembly required

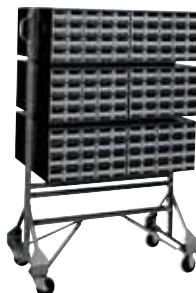

Storage-Go-Round*

Access 20 cabinets and as many as 560 drawers in less than three square feet of floor space. Holds up to 1,000 lbs. of parts.

Accommodates Akro-Mils 19-Series Steel Cabinets (sold separately).

Order These Components and Quantities

- 98325 Storage-Go-Round with turntable base
- Assembled Storage-Go-Round stands 31" L x 31" W x 60" H (787 x 787 x 1524 mm)

19-Series Cabinets – Mix or Match – Qty: 20

*Assembly required



Storage Cabinets



I.D. Size: 4³/₈W x 2H x 5¹/₄L



I.D. Size: 2¹/₈W x 1¹/₂H x 5¹/₄L

Akro-Mils' clarified polypropylene drawers are the best in the industry!

- Unbreakable – no cracked drawers in shipping unlike polystyrene drawers
- Flexible, strong, and see-through
- Chemical-resistant

- Strong plastic cabinets organize and protect components.
- A variety of drawer configurations provide versatile storage solutions.
- Cabinets stack securely and are wall mountable.
- Dividers won't get lost – molded into cabinet back.



10116



10126



10144



10164

Storage Cabinets

Model No.	Description	Inches			mm			Ctn. Qty.
		L	W	H	L	W	H	
10116	16-Drawer Cabinet	10 ⁹ / ₁₆	8 ¹ / ₂	6 ³ / ₈	268	216	162	1
10126	26-Drawer Cabinet	20	10 ¹ / ₂	6 ³ / ₈	508	263	162	1
10124	24-Drawer Cabinet	20	15 ¹ / ₁₆	6 ³ / ₈	508	402	162	1
10144	44-Drawer Cabinet	20	15 ¹ / ₁₆	6 ³ / ₈	508	402	162	1
10164	64-Drawer Cabinet	20	15 ¹ / ₁₆	6 ³ / ₈	508	402	162	1

16-Drawer Cabinet has 8 dividers. All other cabinets have 8 small and 4 large dividers.

Portable Organizers



New! Flat-bottom organizer holds large, bulky items in main compartment.

- Combination small and large parts storage.
- Unique design keeps parts and equipment from migrating to other compartments when lids are shut.
- Separate lid compartment holds small items.
- The main compartment holds larger, bulky items.
- Dividers included for both levels.
- Molded-in "feet" allow case to stand upright.
- Organizers are blue with clear lids and black latches. (Flat-bottom organizer has orange latches.)

Carrying handle for easy portability

Latch locks compartments securely



Adjustable and removable dividers provide flexibility

"See through" case allows you to locate items fast

Portable Organizers

Model No.	Description	No. of Compartments	Inches			mm			Ctn. Qty.
			L	W	H	L	W	H	
06115	Lid Storage Organizer	11 to 46 compartments	15	11 ⁵ / ₁₆	3 ³ / ₄	381	287	83	1
06118	Large Lid Storage Organizer	12 to 62 compartments	18 ³ / ₄	13 ³ / ₈	3 ³ / ₈	464	340	92	1
06217	Flat-Bottom Organizer	9 to 32 compartments	11 ¹ / ₁₆	15	3 ⁷ / ₈	303	381	98	6

Storage Cases

Small Cases



0 Fixed Dividers
4 Adjustable Dividers

Medium Cases

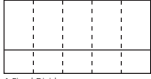

1 Fixed Divider
4 Adjustable Dividers

Small & Medium Cases

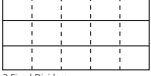

2 Fixed Dividers
4 Adjustable Dividers

Large Cases

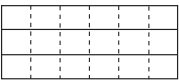

2 Fixed Dividers
5 Adjustable Dividers

- Grid design in lid keeps items from spilling into other compartments.
- Cases available in 3 sizes with different divider configurations.
- Small and medium cases include 4 front-to-back adjustable dividers.
- Large cases include 5 front-to-back adjustable dividers.



Storage Cases

Model No.	Description	Inches			mm			Maximum Compartments	Ctn. Qty.
		L	W	H	L	W	H		
05705	Small Case (2 Fixed Dividers)	8 $\frac{5}{8}$	5 $\frac{1}{8}$	1 $\frac{5}{8}$	219	130	41	15	12
05709	Small Case (0 Fixed Dividers)	8 $\frac{5}{8}$	5 $\frac{1}{8}$	1 $\frac{5}{8}$	219	130	41	5	12
05805	Medium Case (2 Fixed Dividers)	11	7	2 $\frac{3}{8}$	279	178	60	15	6
05807	Medium Case (1 Fixed Divider)	11	7	2 $\frac{3}{8}$	279	178	60	10	6
05905	Large Case (2 Fixed Dividers)	14 $\frac{3}{8}$	9 $\frac{1}{2}$	2 $\frac{1}{2}$	365	241	64	18	6

ProBox™ Tool Boxes



Extra-large trays optimize storage

- ProBox design provides secure stacking on shelves and pallets.
- Carry fully loaded boxes with confidence. Steel draw latch snaps tightly closed.
- Oversized padlock eye accepts larger padlocks for securing tools in ProBox.

Tool Rack

Model No.	Description	L	Inches			mm			Ctn. Qty.
			W	H	L	W	H		
09912	12" ProBox*	12	6	4	305	152	102	12	
09514	14" ProBox	14	8 $\frac{1}{8}$	8 $\frac{1}{8}$	356	197	206	6	
09517	17" ProBox	17	9 $\frac{3}{8}$	8 $\frac{3}{4}$	432	235	245	4	
09920	20" ProBox	20	10 $\frac{1}{4}$	10 $\frac{5}{8}$	508	260	271	4	

* Does not include tray or padlock eye. 17" and 14" trays are red



Tool Rack

- Organizes up to 96 tools.
- Securely mounts to wall.
- Color: Red



Tool Rack

Model No.	Description	L	Inches			mm			Ctn. Qty.
			W	H	L	W	H		
08024RED	Tool Rack	6	24 $\frac{1}{8}$	2 $\frac{3}{4}$	152	613	70	12	

Wrench Holder



- Stores up to 15 wrenches.
- Securely mounts to wall.
- Color: Black



Wrench Holder

Model No.	Description	L	Inches			mm			Ctn. Qty.
			W	H	L	W	H		
08186	Wrench Holder	1	7 $\frac{1}{8}$	8 $\frac{3}{8}$	11 $\frac{5}{8}$	181	295	12	

Tilt & Locks



- Versatile small parts organizer.
- Locking storage bins make this unit great in vehicles, mounted behind doors, or anywhere a convenient storage center is needed.
- Three sizes stack and lock together to form a customized storage center.
- Color: Blue frame with black latches and clear bins.

Bins tilt out completely and, when removed, stand alone for easy access.

Tilt & Locks

Model No.	Description	Inches			mm			Ctn. Qty.
		L	W	H	L	W	H	
08146	Small	19 $\frac{5}{8}$	2 $\frac{3}{4}$	5 $\frac{1}{4}$	498	70	133	1
08166	Medium	19 $\frac{5}{8}$	3 $\frac{3}{4}$	6 $\frac{7}{8}$	498	95	175	1
08186	Large	19 $\frac{5}{8}$	5 $\frac{3}{4}$	8 $\frac{3}{8}$	498	146	213	1



Akro/Logic™ Organizers



- European-inspired organizers for convenient transport and compartmentalized storage.
- Removable bins are interchangeable with other Akro/Logic organizers.
- Heavy-duty polypropylene base and shatterproof polycarbonate lid withstand years of abuse.
- Color: Blue base with red latches and handle.

Akro/Logic™ Multi Case

Model No.	Description	Bins Per Case	Case Dimensions						Ctn. Qty.
			Inches			mm			
			L	W	H	L	W	H	
14217	Multi Case 17	17	12 $\frac{7}{8}$	16 $\frac{1}{4}$	2 $\frac{1}{8}$	327	413	54	4
14212	Multi Case 12	12	12 $\frac{7}{8}$	16 $\frac{1}{4}$	3 $\frac{1}{8}$	327	413	79	3

(Product of Denmark)



Roto-Shelf

- Mobile storage unit can easily be moved to different work areas.
- Roto-Shelf is ideal for assembly components.
- 19 $\frac{7}{8}$ " wide unit takes up very little floor space.
- Four shelves rotate on an independent central metal shaft.
- Color: Gray.

Roto-Shelf

Model No.	Inches		mm		Ctn. Qty.
	D	H	W	H	
02420	19 $\frac{7}{8}$	37 $\frac{1}{2}$	502	953	1

Shelf depth - 2 $\frac{1}{8}$ "
Shelf diameter - 19 $\frac{7}{8}$ "
75 lbs. per shelf
300 lb. total wt. capacity

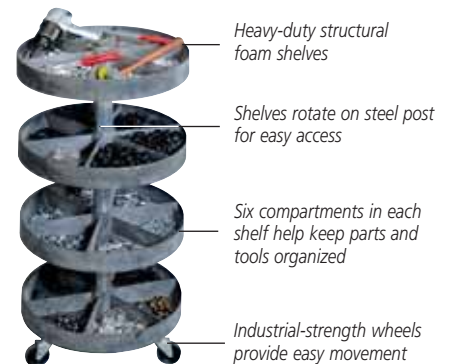



Fire Supply
COLUMBUS, OHIO
BUCKHORN





52-53
ProCart™
 The first box-top to flat-top utility cart.



53
Office Carts
 Lightweight carts for office management.



54-55
VERSA/Deck™
 Versatile cart with multiple handle, rail, and caster options.



56-58
Wood Platform Trucks
 Platform trucks with hardwood decks.



59
Work Height Platform Trucks
 Fixed and adjustable height decks.



60
Steel Platform Trucks
 Medium and heavy-duty steel trucks.



61
Compact Tote Truck
 All-purpose truck with fold-down handle.



61
Shelf & Multi-Shelf Carts
 Sturdy, all-welded steel shelving carts.



62
Portable Tables & Carts
 Steel carts for pulling stock, assembly operations, or other heavy tasks.



63
High-End Narrow Aisle Truck
 Slim truck for use where space is limited.



63
Tray Service Cart
 Heavy-duty service cart holds dishes, books, or supplies for easy transport.



63
Box Trucks
 Steel box on wheels for distribution, order picking, or manufacturing.



64
Heavy-Duty Work Bench
 Durable work station with optional accessory packages.



65
Mobile Work Tables
 Medium and heavy-duty portable work centers.

Carts & Transport Systems

ProCart™

- A customizable work center for the assembly line, warehouse, or wherever you need portable storage.
- Side gates flip up or down to convert to a flat-top or box-top cart.
- High-density polyethylene structural foam construction is dent-resistant, rust-proof, and never needs painting.
- Optional nine-rail hanging system (pg. 53) holds up to 80 AkroBins.
- Optional middle shelf (100 lb. capacity).
- 400lb (180 kg) maximum cart load. 200 lb. (90 kg) capacity per top and bottom shelf.
- Assembly required.



ProCart converts from box top to flat top – quickly adapting to the task at hand.



Large ProCart (Model 30936)
with top and bottom side gates in "box-top" position.

Small ProCart (Model 30930)
with top shelf side gates in "flat-top" position.

Hinged side gates on both shelves flip up or down to convert the ProCart to a flat-top or box-top cart



Deep, molded-in compartments keep small items within reach – yet secured – during transport (Only large cart has mug holder)

Comfortable, full-width handles give complete handling control



Optional nine-rail system and AkroBins (sold separately) offer complete organization and storage



Toe-touch, locking swivel wheels

I-beam post for easy loading and unloading of oversized boxes on the lower shelf

Durable, non-marking 5" wheels

Smooth, rounded corners and edges

ProCart™ Ordering Information

Model No.	Description	Outside Dimensions						Color	Ctn. Qty.
		L	Inches W	H	L	mm W	H		
30936	Large cart	45	24	34¾"	1143	610	883	Gray/Beige	1
30930	Small cart	40	19½"	34¾"	1016	495	883	Gray/Beige	1

Easy assembly – requires Phillips screwdriver and rubber mallet

Large Cart

Model No. 30936

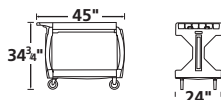

Small Cart

Model No. 30930

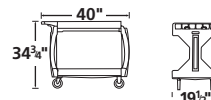

ProCart Accessories:

ProCart Middle Shelf

Add a middle shelf to the ProCart for more efficient use of lower cart space. Two height options. 100 lb. capacity. 40" L x 20" W x 3" H (1016 x 508 x 76mm). Fits large ProCart only. Color: Gray. **Model No. 30936SHELF**



Middle Shelf maximizes lower cart space

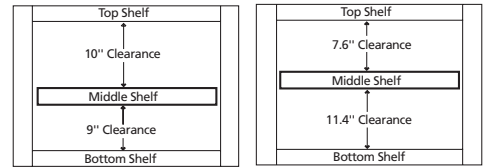

Shelf can be installed in two positions.

AkroBins® Ordering Information

To create a customized ProCart with AkroBins, use the chart below to determine the quantity of AkroBins that will fit your ProCart. Carts, rail kits, and bins must be ordered separately. When ordering, please specify Red, Yellow, Blue, or Stone colored bins.



Optional 9-Rail Hanging System Ordering Information

The 9-Rail Hanging System is required to hang some AkroBins and modular cabinets on your ProCart. For large cart rails, order **Model No. 30906** – for small cart rails, order **Model No. 30900**.



Use this chart when ordering one size AkroBins for your ProCart:

Bin Model No.	30210	30220	30224	30230	30234	30235	30239	30240	30250	30255
Bin Dim. (L" x W" x H")	5 ³ / ₈ x 4 ¹ / ₈ x 3	7 ³ / ₈ x 4 ¹ / ₈ x 3	10 ⁷ / ₈ x 4 ³ / ₁₆ x 4	10 ⁷ / ₈ x 5 ¹ / ₂ x 5	14 ³ / ₄ x 5 ¹ / ₂ x 5	10 ⁷ / ₈ x 11 x 5	10 ³ / ₄ x 8 ¹ / ₄ x 7	14 ³ / ₄ x 8 ¹ / ₄ x 7	14 ³ / ₄ x 16 ¹ / ₂ x 7	10 ³ / ₄ x 16 ¹ / ₂ x 5
30936 (large cart)	80	80	48	36	36	18	16	16	8	12
30930 (small cart)	70	70	42	30	–	12	12	–	–	–

File Manager Cart



- Easy assembly – legs quickly snap together, no tools needed
- Rolls under most work areas
- Includes File Manager Box for organizing letter and legal folders
- 45-pound capacity



File Manager Cart

Model No.	Description	Inches			mm			Ctn. Qty.
		L	W	H	L	W	H	
95418	File Manager Cart	21 ¹ / ₃	14 ⁵ / ₁₆	23 ¹ / ₈	557	365	587	1

Shelf Cart

- Easy assembly – legs quickly snap together, no tools needed
- Free work space of printers, CPUs, books, and more
- 45-pound capacity



Shelf Cart

Model No.	Description	Inches			mm			Ctn. Qty.
		L	W	H	L	W	H	
95492	Shelf Cart	19	14 ⁵ / ₁₆	23 ¹ / ₈	484	365	587	1

VERSA/Deck™

- Versatile, structural foam cart with multiple handle and caster options.
- Sturdy, easy-to-clean deck resists most chemicals and damage from long-term exposure to weather.
- All decks are steel reinforced.
- Maximize deck space with outside deck handles.
- Choose the deck size, caster type, and handle style to create the exact configuration you need.
- Decks are available in two sizes: 24" x 48" and 30" x 60".
- Deck colors: Blue or Gray.



VERSA/Deck™ is perfect for transporting long, tall, or bulky items.

Common VERSA/Deck™ Configurations



24" x 48"
R90181 Deck
R92411 18" Handle



24" x 48"
R90181 Deck
Two R94817 48" Rails
One R94815 48" Rail



24" x 48"
R90181 Deck
Two R92418 24" Handles
One R92416 24" Handle



24" x 48"
R90181 Deck
One R92411 18" Handle
Two R94817 48" Rails



24" x 48"
R90181 Deck
Two R92418 24" Handles



24" x 48"
R90181 Deck
Two R92411 18" Handles
One R94815 48" Rail



30" x 60"
R90281 Deck
R93011 24" Handle



30" x 60"
R90281 Deck
Two R94817 60" Rails
One R96015 60" Rail



30" x 60"
R90281 Deck
Two R93019 30" Handles
One R93016 30" Handle



30" x 60"
R90281 Deck
One R93011 24" Handle
Two R96017 60" Rails



30" x 60"
R90281 Deck
Two R93019 30" Handles



30" x 60"
R90281 Deck
Two R93011 24" Handles
One R96015 60" Rail

Carts & Transport Systems

VERSA/Deck shown with Akro-Mils SWC's and Akro-Grids (See pages 23-25).

HOW TO ORDER

Step 1
Pick a deck size.

Step 2
Pick a caster type.

Step 3
Refer to the decks & casters charts for model numbers.

Step 4
Pick handle and rail styles, and determine the quantity needed of each type.

Step 5
Refer to the handle and rail charts for model numbers.

Step 6
Call your Akro-Mils distributor to order.

1

Deck Sizes

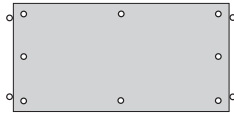

24" x 48" (610mm x 1219mm)
30" x 60" (762mm x 1524mm)
Color: Gray or Blue

2

Casters & Wheels

Caster & Wheel choices allow you to resolve problems of noise control, floor protection, impact or abrasion resistance, or load capacity. See page 76 for more caster information.



3

24" x 48" Decks & Casters

Model No.	Caster Type	Caster Size Inches	Caster Size mm	Load Rating	Ship. Wt. w/o handles
R90152	Moldon Rubber	5	127	1400 lbs.	65 lbs.
R90181	Pneumatic	8	203	1200 lbs.	69 lbs.
R90162	Polyolefin	6	152	1500 lbs.	61 lbs.
R90163	Polyurethane	6	152	2000 lbs.	61 lbs.
R90182	Moldon Rubber	8	203	2000 lbs.	81 lbs.
R90184	Polyolefin	8	203	1500 lbs.	65 lbs.
R90110	Pneumatic	10	254	1600 lbs.	77 lbs.
R90153	Performa	5	127	1500 lbs.	57 lbs.
R90164	Pro-Tech Non-Marking	6	152	2700 lbs.	61 lbs.
R90183	Pro-Tech Non-Marking	8	203	2700 lbs.	61 lbs.
R90185	Gray Round Performa	8	203	2400 lbs.	61 lbs.

Note: Decks are available in Gray or Blue. Specify color when ordering.

30" x 60" Decks & Casters

Model No.	Caster Type	Caster Size Inches	Caster Size mm	Load Rating	Ship. Wt. w/o handles
R90252	Moldon Rubber	5	127	1400 lbs.	89 lbs.
R90281	Pneumatic	8	203	1200 lbs.	93 lbs.
R90262	Polyolefin	6	152	1500 lbs.	85 lbs.
R90263	Polyurethane	6	152	2000 lbs.	85 lbs.
R90282	Moldon Rubber	8	203	2000 lbs.	105 lbs.
R90284	Polyolefin	8	203	1500 lbs.	89 lbs.
R90210	Pneumatic	10	254	1600 lbs.	101 lbs.
R90253	Performa	5	127	1500 lbs.	81 lbs.
R90264	Pro-Tech Non-Marking	6	152	2700 lbs.	85 lbs.
R90283	Pro-Tech Non-Marking	8	203	2700 lbs.	85 lbs.
R90285	Gray Round Performa	8	203	2400 lbs.	85 lbs.

4

Handle – Outside Deck

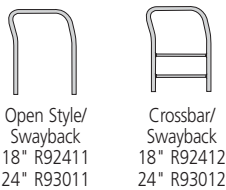

Handle – Indeck

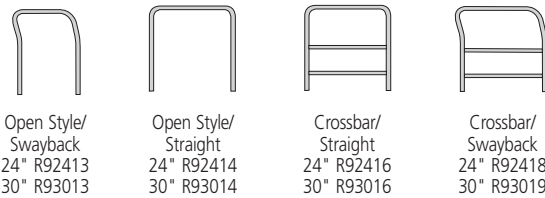

Handle Rails – Indeck

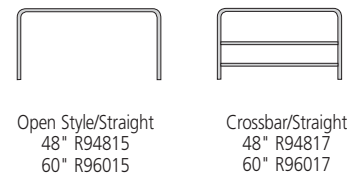

5

Handles & Rails for 24" x 48" VERSA/Deck Cart

Model No.	Size Inches	Size mm	Style	Handle	Color	Ship. Wt.
Outside Deck						
R92411	18	457	Open	Swayback	Gray	5
R92412	18	457	Crossbars	Swayback	Gray	6
Indeck						
R92413	24	610	Open	Swayback	Gray	6
R92414	24	610	Open	Straight	Gray	6
R92416	24	610	Crossbar	Straight	Gray	8
R92418	24	610	Crossbar	Swayback	Gray	8
Handle Rails Indeck						
R94815	48	1219	Open	Straight	Gray	7
R94817	48	1219	Crossbar	Straight	Gray	14

Handles & Rails for 30" x 60" VERSA/Deck Cart

Model No.	Size Inches	Size mm	Style	Handle	Color	Ship. Wt.
Outside Deck						
R93011	24	610	Open	Swayback	Gray	9
R93012	24	610	Crossbar	Swayback	Gray	10
Indeck						
R93013	30	762	Open	Swayback	Gray	10
R93014	30	762	Open	Straight	Gray	10
R93016	30	762	Crossbar	Straight	Gray	12
R93019	30	762	Crossbar	Swayback	Gray	12
Handle Rails Indeck						
R96015	60	1524	Open	Straight	Gray	8
R96017	60	1524	Crossbar	Straight	Gray	16

Platform Trucks Wood Deck



Platform trucks make transport of heavy loads easy. (Shown with Akro-Mils containers. See pages 18-25)

- Heavy-duty platform trucks with kiln-dried, tongue and groove hardwood decks.
- Caster options allow 1,180 to 5,400 lb. capacities.
- Choose from multiple options in deck type, size, handles, casters, running gear patterns, bumpers, and wheel locks.
- Decks are 4/4" (1" thick).
- Shipped completely assembled and ready to use.

Shown with removable cross bar handle. Choose from multiple handle options below.

Hardwood deck with tongue & groove construction



Bolt heads are countersunk and secured with lock nuts for a smooth working surface

Heavy-duty casters

Deck Sizes

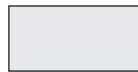

24" x 48"



27" x 54"



30" x 60"



36" x 72"

HOW TO ORDER

- Step 1**
Pick deck size.
- Step 2**
Pick deck style
Series 1, 2, or 3.
- Step 3**
Pick superstructure
A through H.
- Step 4**
Pick running gears
1 through 7.
- Step 5**
Pick caster type & size.
- Step 6**
Create a model number
and call your Akro-Mils
distributor.

2



Series 1

All Wood

- Shown with removable lattice pipe handle at swivel end.
- Two swivel, two rigid casters.
- See caster options for capacity.



Series 2

Wood Deck with Steel Frame

- Heavy-duty cart for concentrated loads.
- 2" x 2" x 1/8" welded steel angle frame. (on 36" x 72" deck, 2" x 2" x 3/16")
- Shown with removable lattice pipe handle at swivel end.
- The wood deck is reinforced with longitudinal stiffeners for maximum capacity. (See caster options for capacity.)
- Two swivel, two rigid casters.



Series 3

Wood Deck with Steel Corners

- Steel plates protect corners from damage.
- Shown with open pipe handle.
- Reinforcing center sill supports the deck lengthwise from beneath.
- Series 3 trucks feature 12" load wheels in combination with 8" swivel casters. See "Casters and Wheels Series 3" chart on page 57.

Also Available

Super Heavy-Duty Wood Deck Steel Frame Trucks



- Steel C-channel underdeck reinforcements.
- Capacity – 1,200 to 4,000 lbs. depending on caster type.
- Contact your Akro-Mils distributor to order.

3

Superstructures

Choose a handle style from the chart below to fit your platform truck. Open, lattice, and stake styles are removable to fit oversize loads. Fixed handles are only available on Series 1 & 2 trucks.



Open pipe handle
26 3/4" above deck.



Cross bar handle
26 3/4" above deck. Cross bars prevent small items from sliding through.



Pipe stakes
36" above deck. Available on Series 1 & 2



Hardwood stakes*
31" above deck. Available on Series 3 decks only.

Superstructures (Handles & Stakes)

Series 1 & 2	Removable	Fixed
Series 3	Removable	

*Hardwood stakes available with Series 3 only.

4

Running Gears

 Rigid caster

 Swivel caster

 Fixed wheel on axle

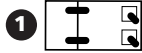

1
Non-Tilt
Series 3 only



4
Non-Tilt
Series 1 & 2

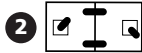

2
Tilt
Series 3 only

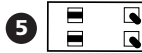

5
Non-Tilt
Series 1 & 2

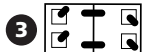

3
Tilt Quad
Series 3 only



6
Tilt
Series 1 & 2



7
Tilt Quad
Series 1 & 2

5

Casters & Wheels

Series 1 & 2	Material*	Size (D x W)		Series 1 & 2 Load Capacities
		Inches	mm	
L	Phenolic	6 x 2	152 x 51	3200 lbs.
P	Polyolefin	5 x 2 6 x 2	127 x 51 152 x 51	2600 lbs. 2800 lbs.
M	Moldon Rubber	5 x 2 6 x 2 8 x 2	127 x 51 152 x 51 203 x 89	1500 lbs. 1760 lbs. 2000 lbs.
Y	Polyurethane	6 x 2	152 x 51	3200 lbs.
N	Pneumatic	8 x 2 10 x 3.5	203 x 51 254 x 89	1180 lbs.
R	Non-Marking Rubber	6 x 2	152 x 51	1640 lbs.
S	Steel	6 x 2 8 x 3	152 x 51 203 x 76	3200 lbs.

Series 3

Caster Type & Load Capacity	Moldon Rubber	Polyurethane	Steel
	Running Gear 1 & 3	3280 lbs.	5400 lbs.
Running Gear 2	2780 lbs.	4500 lbs.	4500 lbs.

Note: For Series 3 model numbers, specify load wheel type (M, Y, or S) and a 12" wheel diameter. Swivel casters are standard 8" diameter.

*See page 76 for full description of casters and wheels.

6

HOW TO CREATE YOUR MODEL NUMBER

Platform Truck	Size	Series	Superstructure	Running Gear Type	Caster Wheel	Caster Wheel Diameter
RPT	2448 2754 3060 3672	1 2 3	A B C D F G H J K	1 2 3 4 5 6 7	L P M Y N R S	5 6 8 10 12
Example: RPT	3060	2	A	5	P	6

For a 30" x 60" wood with steel frame platform truck with one removable open pipe handle and two rigid, two swivel 6" polyolefin casters, your model number will look like this: **RPT30602A5P6**

Options & Accessories*

*Accessories and special-order products are not returnable.

Floor Locks



Prevent unwanted truck movement. Step down to lock, trip to release. Normally installed between swivel casters.

- Non-slip rubber base
- Solid steel construction
- Zinc plated for corrosion resistance
- For use on trucks with non-tilt running gear only

Wheel Locks



Control truck movement: prevent wheels from turning. Available on all wheels. Normal installation on two swivel wheels.

Corner Bumpers



Protect walls, doors, furniture from damage.

Continuous Bumpers



Complete edge protection for all platform trucks.

Supply Caddy Model No. R90000



Six deep pockets hold clipboards, tape guns, and other bulky items. Durable canvas with nylon hanging straps and velcro fasteners. 16" W x 26" H. Fits all platform trucks. Order separately. Color: Black.

Wood Platform Decks

Our Premium Decks are constructed from the highest quality hardwoods to ensure maximum service under extreme conditions.

Premium Wood Decks

- Custom platform hardwood decks.
- Choose the deck, size, wheels, and running gear to best fit your application.
- Premium hardwood decks in 1 1/4" (5/4) or 1" (4/4) thickness.
- Decks are predrilled to accept a 4" x 4 1/2" top plate with bolt hole spacing of 2 3/4" x 3 5/16".



Decks, handles, and casters must be ordered separately. Refer to page 56 for caster and handle options. (Shipped unassembled. Assembly available for extra charge.)

Deck boards run lengthwise on premium models, crosswise on standard models

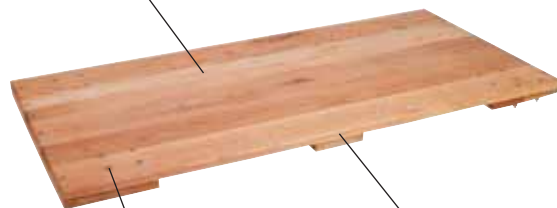

Decks are predrilled for two fixed and two swivel wheels. See chart for other running gear options.

Treated and sealed hardwood deck with smooth, routed edges

HOW TO ORDER

Select the model no. from the chart and add "44" or "54" to specify 4/4" or 5/4" thickness.

Use this chart when ordering premium 5/4 or 4/4 wood platform decks. Boards run lengthwise.

Deck Width	Deck Length										
	24"	36"	42"	46"	48"	54"	60"	66"	72"	84"	96"
24"	R6100	R6101	R6111	R6121	R6131	R6139					
27"					R6144	R6151					
30"					R6141	R6170	R6171	R6175	R6191	R6193	
36"					R6180	R6181		R6199	R6194		

Note: When ordering, add "44" or "54" to specify 4/4" or 5/4" thickness. Example: R615144 is a 54" x 27" premium deck with 4/4" thick boards.

Standard Wood Decks

SERIES 1



Deck Only

- Tongue & groove deck construction.
- 1" (4/4) thick hardwood deck with routed edges.
- Predrilled for running gear 5.
- Predrilled for (1) handle.

Series 1 Wood Decks

Model No.	Size		Ship Wt.
	Inches	mm	
RPTD24481	24 x 48	609 x 1219	33 lbs.
RPTD27541	27 x 54	686 x 1372	42 lbs.
RPTD30601	30 x 60	762 x 1524	54 lbs.
RPTD36721	36 x 72	914 x 1829	74 lbs.

Decks are predrilled to accept a 4" x 4 1/2" top plate with bolt hole spacing of 2 3/4" x 3 5/16".

SERIES 2



Deck Only

- Tongue & groove hardwood in angle frame.
- 1" (4/4) thick hardwood deck with routed edges.
- Predrilled for running gear 5. Equipped for (1) handle, with 2 sockets installed.

Series 2 Wood Decks

Model No.	Size		Ship Wt.
	Inches	mm	
RPTD24482	24 x 48	609 x 1219	58 lbs.
RPTD27542	27 x 54	686 x 1372	69 lbs.
RPTD30602	30 x 60	762 x 1524	83 lbs.
RPTD36722	36 x 72	914 x 1829	122 lbs.

Options for Premium and Standard Wood Decks:

Running Gear Detail

- Rigid caster
- Swivel caster
- Fixed wheel on axle

Running Gear Options for Premium and Standard Wood Decks

- 4** **Non-Tilt** Series 1 & 2
- 5*** **Non-Tilt** Series 1 & 2

*Standard running gear

- 6** **Tilt** Series 1 & 2
- 7** **Tilt Quad** Series 1 & 2



Decks, handles, and casters must be ordered separately. Refer to page 56 and 57 for caster and handle options. (Assembly required)

Platform Trucks Work Height



Hardwood Deck



Structural Foam Deck



Expanded Metal Shelf

- Hardwood or structural foam deck available.
- Ergonomic height reduces the strain of lifting and bending.
- 26½"H fixed or adjustable height decks.
- Adjustable height trucks have 3 deck height settings; 24½" to 30½"H on trucks with 6" wheels, and 25½" to 31½"H on trucks with 8" wheels.
- See optional accessories, page 57.
- Optional expanded metal lower shelf (Special-order products are not returnable.)



DECK SIZES 24" x 48" & 30" x 60"

Fixed Height Platform Trucks

Model No.		Caster Type*	Caster Size	
Hardwood	Structural Foam		Inches	mm
24" x 48" Decks (610 x 1219mm)				
RWH24481A5M6	RWHV24481A5M6	Moldon	6	152
RWH24481A5M8	RWHV24481A5M8	Moldon	8	203
RWH24481A5Y6	RWHV24481A5Y6	Polyolefin	6	152
30" x 60" Decks (762 x 1524mm)				
RWH30601A5M6	RWHV30601A5M6	Moldon	6	152
RWH30601A5M8	RWHV30601A5M8	Moldon	8	203
RWH30601A5Y6	RWHV30601A5Y6	Polyolefin	6	152

Adjustable Height Platform Trucks

Model No.		Caster Type*	Caster Size	
Hardwood	Structural Foam		Inches	mm
24" x 48" Decks (610 x 1219mm)				
RWH24481A5M6A	RWHV24481A5M6A	Moldon	6	152
RWH24481A5M8A	RWHV24481A5M8A	Moldon	8	203
RWH24481A5Y6A	RWHV24481A5Y6A	Polyolefin	6	152
30" x 60" Decks (762 x 1524mm)				
RWH30601A5M6A	RWHV30601A5M6A	Moldon	6	152
RWH30601A5M8A	RWHV30601A5M8A	Moldon	8	203
RWH30601A5Y6A	RWHV30601A5Y6A	Polyolefin	6	152

*See page 76 for full description of casters and wheels.

Skids Semi-Live & Dead

Choose from steel, wood, or wood with steel frame



DECK SIZES 24" x 36" 27" x 54" 36" x 60"
24" x 48" 30" x 48" 36" x 72"
24" x 60" 30" x 60"

Dead Skids Specify size when ordering.

Model No.	Underclearance	Capacity
All Wood Dead Skid		
RA121DS*	7¼" (184mm)	3000 lbs.
Wood Deck Steel Frame Dead Skids		
R121DS	7¼" (184mm)	3000 lbs.
All Steel Dead Skid		
R120DS	7¼" (303mm)	3000 lbs.

*Not available in 24" x 36", 27" x 54", and 24" x 60" deck sizes.

DECK SIZES 24" x 36" 30" x 48"
24" x 48" 30" x 60" 36" x 60"
27" x 54" 30" x 72" 36" x 72"

Semi-Live Skids

Specify size when ordering.

Model No.	Caster Capacity	Caster Type*	Caster Inches	Caster mm	Underclearance of Tongue
All Wood Semi-Live Skids					
RA756MR**	1800 lbs.	Moldon	6 x 2	152 x 51	6⅞" (175mm)
RA778MR**	2200 lbs.	Moldon	8 x 2	203 x 51	9⅛" (232mm)
RA796PL**	2500 lbs.	Phenolic	6 x 2	152 x 51	6⅞" (175mm)
RA7218PL	3000 lbs.	Phenolic	8 x 2	203 x 51	9⅛" (232mm)
Wood Deck Steel Frame Semi-Live Skids					
R756MR	1800 lbs.	Moldon	6 x 2	152 x 51	6⅞" (175mm)
R778MR	2200 lbs.	Moldon	8 x 2	203 x 51	9⅛" (232mm)
R796PL	2500 lbs.	Phenolic	6 x 2	152 x 51	6⅞" (175mm)
R7218PL	3000 lbs.	Phenolic	8 x 2	203 x 51	9⅛" (232mm)
All Steel Semi-Live Skids					
R746MR	1800 lbs.	Moldon	6 x 2	152 x 51	6⅞" (175mm)
R768MR	2200 lbs.	Moldon	8 x 2	203 x 51	9⅛" (232mm)
R786PL	2500 lbs.	Phenolic	6 x 2	152 x 51	6⅞" (175mm)
R7208PL	3000 lbs.	Phenolic	8 x 2	203 x 51	9 ⅛" (232mm)

** Not available in 24" x 36", 27" x 54", and 30" x 72" deck sizes.

*See page 76 for full description of casters and wheels.

Optional Lift Jack

- For easy transport of most semi-live skids.
- Specify "T" or loop handle style.
- For female socket, change Model No. prefix to "RF".
- Pipe is 43" long

Optional Lift Jack

Model No.	Caster Type*	Caster Size
RM716MR	Moldon Rubber	6" (152mm)
RM718MR	Moldon Rubber	8" (303mm)
RM716PL	Phenolic	6" (152mm)
RM718PL	Phenolic	8" (303mm)

*See page 76 for full description of casters and wheels.

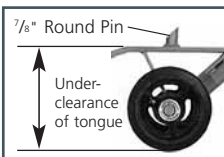

Platform Trucks Steel



Shown with Akro-Mils SWC's and Akro-Grids. See pages 23-25.

- Medium and heavy-duty steel trucks with longitudinal steel underdeck reinforcements.
- Standard two swivel, two rigid casters.
- Special-order platform trucks are available. See pages 56 and 57 to select from multiple options in handles, casters, and running gears. (Special-order products are not returnable.)
- Caster options allow 800 to 2,200 lb. capacity.

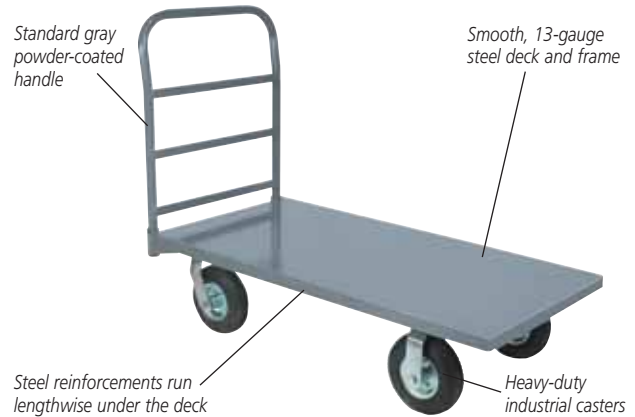

HEAVY-DUTY DECK SIZES	24" x 36"	27" x 54"	30" x 72"
	24" x 48"	30" x 48"	36" x 60"
	24" x 60"	30" x 60"	36" x 72"



Standard cross bar handle

Heavy-Duty

Specify size when ordering.

Model No.	Caster Capacity	Caster Type*	Caster Size (Swivel & Rigid)		Deck Height	
			Inches	mm	Inches	mm
R2108FPB	1200 lbs.	Full Pneumatic	8 (4 Ply)	203	11½	292
R21210FPB	1200 lbs.	Full Pneumatic	10 (2 Ply)	254	13½	343
R2125MRB	1500 lbs.	Moldon Rubber	5 x 2	127 x 51	8	203
R21412FPB**	1600 lbs.	Full Pneumatic	12 (2 Ply)	305	17¼	438
R2161012FPB	1700 lbs.	Full Pneumatic	10 (2 Ply) – Swivel – 12 (4 Ply) – Rigid –	254 305	14½	368
R2146MRB	1800 lbs.	Moldon Rubber	6 x 2	152 x 51	9	229
R2168MRB	2200 lbs.	Moldon Rubber	8 x 2	203 x 51	11	279
R2165PLB	2200 lbs.	Phenolic	5 x 2	127 x 51	8	203
R2165PYB	2200 lbs.	Polyurethane	5 x 2	127 x 51	8	203
R2165SSB	2200 lbs.	Semi-Steel	5 x 2	127 x 51	8	203

** Not available in 24" x 36", 24" x 48", and 24" x 60" deck sizes. *See page 76 for full description of casters and wheels.

MEDIUM-DUTY DECK SIZES	18" x 36"	24" x 36"
	20" x 32"	24" x 48"



Standard open pipe handle

Medium-Duty

Model No.	Caster Capacity	Caster Type*	Caster Size (Swivel & Rigid)	
			Inches	mm
RMD2104MRA	800 lbs.	Moldon Rubber	4 x 2	102 x 51
RMD2105SRA	800 lbs.	Soft Rubber	5 x 1¼	127 x 32

*See page 76 for full description of casters and wheels.

Options & Accessories*:

*Accessories and special-order products are not returnable.

Floor Locks



Prevent unwanted truck movement. Step down to lock, trip to release. Normally installed between swivel casters.

- Non-slip rubber base
- Solid steel construction
- Zinc plated for corrosion resistance
- For use on trucks with non-tilt running gear only

Wheel Locks



Control truck movement: prevent wheels from turning. Available on all wheels. Normal installation on two swivel wheels.

Corner Bumpers



Protect walls, doors, furniture from damage.

Continuous Bumpers



Complete edge protection for all platform trucks.

Shelf & Multi-Shelf Carts



- Heavy-duty carts designed for daily work.
- Welded steel cart rolls smoothly on long-wearing casters.
- Built to withstand loads up to 2,200 lbs.
- Swayback-style tubular push handle. (Models R1S5HR and R1S8MR have straight handles)
- Choose from several caster options as well as: rubber matting, lips up or down, a writing shelf, and drawers. (See pg. 62)
- Ships completely assembled and ready to use.



CART SIZES		Specify size when ordering.
18" x 30"	24" x 60"	
18" x 36"	27" x 54"	
24" x 36"	30" x 48"	
24" x 42"	30" x 60"	
24" x 48"	36" x 72"	



Caster Note:
Caster & Wheel choices allow you to resolve problems of noise control, floor protection, impact or abrasion resistance, or load capacity. See page 76 for more caster information.

Shelf Carts

Model No.	Caster Capacity	Caster Type*	Caster Size		Shelves	Height To Top Shelf		Shelf Clearance	
			Inches	mm		Inches	mm	Inches	mm
R1S8FP2*	1200 lbs.	Full Pneumatic	8 (4 Ply)	203 x 102	2	34	864	20 ³ / ₄	527
R1S10FP2*	1200 lbs.	Full Pneumatic	10 (2 Ply)	254 x 51	2	36	914	20 ³ / ₄	527
R1S12FP2**	1600 lbs.	Full Pneumatic	12 (2 Ply)	305 x 51	2	39 ³ / ₄	1010	20 ³ / ₄	527
R1S5HR [†]	1800 lbs.	Polyolefin	5 x 2	127 x 51	2	30 ¹ / ₄	768	20 ³ / ₄	527
R1S5HR2	1800 lbs.	Polyolefin	5 x 2	127 x 51	2	30 ¹ / ₄	768	20 ³ / ₄	527
R1S5HR2LD	1800 lbs.	Polyolefin	5 x 2	127 x 51	2	25	635	15 ¹ / ₂	394
R1S8MR [†]	2200 lbs.	Moldon Rubber	8 x 2	203 x 51	2	33 ¹ / ₄	845	20 ³ / ₄	527
R1S8MR2	2200 lbs.	Moldon Rubber	8 x 2	203 x 51	2	33 ¹ / ₄	845	20 ³ / ₄	527
R1S8MR2LD	2200 lbs.	Moldon Rubber	8 x 2	203 x 51	2	28	711	15 ¹ / ₂	394

*Not available in 18" x 30" and 18" x 36" deck sizes. **Only available in 27" x 54", 30" x 48", 30" x 60", and 36" x 72". [†]Straight handle.

Multi-Shelf Carts

Model No.	Caster Capacity	Caster Type*	Caster Size		Shelves	Overall Height		Clear Shelf Spacing	
			Inches	mm		Inches	mm	Inches	mm
R2S5HR	1800 lbs.	Polyolefin	5 x 2	127 x 51	2	30 ¹ / ₄	768	20 ³ / ₄	527
R2S8MR	2200 lbs.	Moldon Rubber	8 x 2	203 x 51	2	33 ¹ / ₄	845	20 ³ / ₄	527
R3S5HR	1800 lbs.	Polyolefin	5 x 2	127 x 51	3	30 ¹ / ₄	768	9 ³ / ₈	244
R3S8MR	2200 lbs.	Moldon Rubber	8 x 2	203 x 51	3	33 ¹ / ₄	845	9 ³ / ₈	244
R4S5HR	1800 lbs.	Polyolefin	5 x 2	127 x 51	4	63 ¹ / ₄	1619	17	432
R4S8MR	2200 lbs.	Moldon Rubber	8 x 2	203 x 51	4	66 ¹ / ₄	1695	17	432
R5S5HR	1800 lbs.	Polyolefin	5 x 2	127 x 51	5	63 ¹ / ₄	1619	12 ¹ / ₄	311
R5S8MR	2200 lbs.	Moldon Rubber	8 x 2	203 x 51	5	66 ¹ / ₄	1695	12 ¹ / ₄	311

*See page 76 for full description of casters and wheels.

Compact Tote Truck



Supply Caddy
Store supplies in the Heavy-Duty Supply Caddy. Six deep pockets hold clipboards, tape guns, and other bulky items. Durable canvas with nylon hanging straps and velcro fasteners. 16"W x 26"H. Fits all Compact Tote Trucks. Order separately: **Model No. R90000**. Color: Black. 1 per carton.

- All-purpose material handling and transport cart with fold-down handle.
- Deck is constructed of lightweight, high-density structural foam.
- Two fixed, two swivel casters make cart easy to maneuver. (Swivel casters on R90041 are toe-touch locking casters).
- Deck Size - all models: 35¹/₂"L x 22¹/₂"W (904 x 568 mm)

Steel handle is powder coated to resist rusting and folds down flush to deck

Non-skid platform surface prevents load from shifting during transport

Use the molded-in handle to hang the Compact Tote Truck or to secure tie-down straps (not included)



Compact Tote Truck Ordering Information

Model No.	Wheel		Load Rating		Overall Height		Deck Height	
	Inches	mm	Lbs.	kg	Inches	mm	Inches	mm
R90031	3 x 1	76 x 25	300	136	34	864	7	178
R90041	4 x 1	102 x 25	500	227	35	889	8	203
R90062	6 x 2	153 x 51	1000	454	37	940	9	229

Easy assembly - requires Phillips screwdriver and rubber mallet

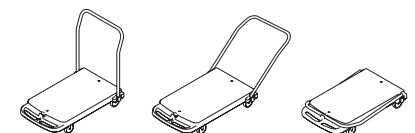

Push/pull handle has three positions for easy maneuvering

Bin Carts

- A convenient combination of a heavy-duty cart with sturdy AkroBins for organized, portable storage of parts or supplies.
- 13-gauge steel, all-welded construction with 1½" x ⅛" angle iron steel.
- Drawer is 15½"W x 5½"H x 16½"D.
- Bolt-on polyurethane casters – 5" x 1¼"; 2 rigid, 2 swivel with total lock brakes.
- Fully assembled with 36" panel and 8 AkroBins.
- One lip down on top shelf for easy access to work surface.
- Frame color: Blue or Gray.
- AkroBin colors: Red, Yellow, Blue, Stone.



Model No. RBCB18365Y shown with optional writing shelf

Bin Cart with Bottom-Shelf Storage

- Cart Dimensions: 18"W x 36"L x 36"H or 24"W x 36"L x 36"H.
 - Standard with tubular push handle.
 - Optional writing shelf.
 - Bin Model No. 30240 (See pg. 4 for sizes).
 - 18" x 36" Model No. RBCB18365Y.
 - 24" x 36" Model No. RBCB24365Y.
- Please specify frame color and bin color.



Model No. RBCT24365Y shown with optional wood inserts

Bin Cart with Top-Shelf Storage

- Dimensions: 24"W x 36"L x 36"H.
 - Tubular push handle.
 - Optional wood inserts.
 - Bin Model No. 30239 (See pg. 4 for sizes).
 - Model No. RBCT24365Y
- Please specify frame color and bin color.

Portable Tables & Carts

- Durable carts for pulling stock, assembly operations, or other heavy tasks.
- Welded steel frame construction with soft rubber casters for easy maneuverability.
- Overall height: 36".
- Ships completely assembled and ready to use.
- 800 lb. capacity.



MD Series

PT Series

- 4 swivel, 5" x 1¼" soft rubber casters.
- Shelf spacing: 2-shelf – 27" (558 mm), 3-shelf – 12½" (318 mm)
- 13-gauge steel.
- 1½" hemmed lip.

PT SERIES CART SIZES

18" x 30" 24" x 36"
18" x 36" 24" x 42"
24" x 30" 24" x 48"

Specify shelf size when ordering.

PT Series

Model No.	Description
RPT2ST5SR	2-Shelf Cart
RPT3ST5SR	3-Shelf Cart

MD Series

- 2 swivel, 2 rigid, 5" x 1¼" soft rubber casters.
- Shelf spacing: 2-shelf – 26" (660 mm), 3-shelf – 12" (305 mm)
- Tubular push handle.
- 16-gauge steel.
- 2" hemmed lip.

MD SERIES CART SIZES

18" x 24" 18" x 36"
18" x 30" 24" x 36"

Specify shelf size when ordering.

MD Series

Model No.	Description
RMD2ST5SR	2-Shelf Cart
RMD3ST5SR	3-Shelf Cart

Options & Accessories*:

*Special-order products are not returnable.

Drawer



Easily accessible storage drawer. 15½"W x 5½"H x 16½"D O.D.

Writing Shelf



Handy, angled shelf with pencil edge.

Rubber Matting



Rubber mats for all standard size shelves.

Wheel Locks



Control truck movement and prevent wheels from turning. Available on all wheels. Normal installation on two swivel wheels.

High-End Narrow Aisle Truck



- Extra-narrow aisle truck for order-picking and stocking where space is limited.
- Slim design fits easily in tight areas.
- Centered, 8" wheels and casters at each corner allow cart to turn within its own diagonal space.
- Available in plywood deck with steel frame, all steel deck, or galvanized steel deck.
- 1,500 lb. capacity.

New!



High-End Narrow Aisle

CART SIZES	Steel & Wood Deck	
	18" x 48"	24" x 48"
Specify deck size when ordering.	18" x 60"	24" x 60"
Galvanized Deck		
	16" x 48"	24" x 48"
	16" x 60"	24" x 60"

Model No.	Deck Type	Caster Capacity	Deck Height		Overall Height	
			Inches	mm	Inches	mm
R215HE	Plywood	1500 lbs.	12 1/4	311	66 1/2	1689
R214HE	Steel	1500 lbs.	11	279	64 1/2	1638
R214HEGA	Galvanized	1500 lbs.	11	279	64 1/2	1638

Tray Service Cart

- Excellent for libraries and manufacturing operations.
- 2 swivel, 2 fixed casters.

CART SIZES	18" x 30"		24" x 36"	
	18" x 36"	24" x 48"		
Specify size when ordering.				

Tray Service Cart

Model No.	Caster Capacity	Caster Type*	Caster Size		Overall Height	
			Inches	mm	Inches	mm
R2T5HR	1800 lbs.	Polyolefin	5 x 2	127 x 51	32 1/2	826
R2T8MR	2200 lbs.	Moldon Rubber	8 x 2	203 x 51	35 1/2	902

*See page 76 for full description of casters and wheels.

Standard Casters Shown (other caster options available):



Polyolefin



Moldon Rubber

Caster Note: Caster & Wheel choices allow you to resolve problems of noise control, floor protection, impact or abrasion resistance, or load capacity. See page 76 for more caster information.



Box Trucks

Expanded Metal Box



Expanded metal for easy cleaning, good airflow, and visibility of contents. 31 1/2" overall height; 25" inside depth.

- All box trucks have 2 swivel, 2 rigid, 5" x 2" polyolefin casters.
- Solid steel or expanded metal sides available.
- 1,800 lb. capacity.
- Available with optional lid.



Box Trucks	BOX SIZES	24" x 36"		30" x 36"	
		24" x 48"	30" x 48"		
Specify size when ordering.					

Model No.	Description	Overall Ht.		Inside Depth	
		Inches	mm	Inches	mm
R1B5HR	Steel Box Truck	30 1/2	775	24	607
R1B5HRLD	Steel Box Truck w/ Lid	30 1/2	775	24	607
R1B5HRX	Expanded Metal Box Truck	31 1/2	800	25	635
R1B5HRXLD	Expanded Metal Box Truck w/ Lid	31 1/2	800	25	635



Standard Caster
Polyolefin
See page 76 for more caster information.

Heavy-Duty Work Benches

New!

- Heavy-duty, steel frame workbench.
- Steel or premium hardwood work surface.
- 34" fixed or adjustable work heights.
- Bench sizes: 30" x 60", 30" x 72".
- Blue or Gray powder coated finish.



*Hardwood Surface
Premium 1 1/4" finished oak with rounded edges for a smooth, durable working surface.*

Optional Accessory Packages

Keep your work center organized with AkroBins® and cabinets. Choose from three accessory packages below or create your own combination from our extensive line of bins and containers (order custom combinations separately). Please specify one bin color per package: Red, Blue, Stone, or Yellow.



Accessory Package 1

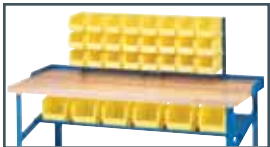

Accessory Package 2



Accessory Package 3

Steel work surface extends 1 1/2" on front and sides to accommodate a vise or clamps (Hardwood extends 2")

Wrap-around steel back stop keeps items from falling behind workbench

11-gauge steel or premium hardwood work surface

Adjustable Work Height
Telescoping C-channel legs provide a range of work heights from 30"H to 40"H. Perfect for adapting to standing or sitting applications.



12-gauge welded steel shelves

13 1/2" deep middle shelf is sloped for easy access to bins or containers

Anchor pads on each leg secure bench in a fixed position

Accessories to fit 30" x 60" workbench

Package 1

- 2 - Bench Racks (Model 98600 Gray)
- 48 - AkroBins (Model 30220)
- 6 - Large AkroBins (Model 30239)

Package 2

- 1 - Rail Kit
- 24 - Medium AkroBins (Model 30230)
- 6 - Large AkroBins (Model 30239)

Package 3

- 1 - Rail Kit
- 1 - 20-Drawer cabinet (Model 19320)
- 1 set - Suspension straps (Model 98400)
- 24 - Small AkroBins (Model 30220)
- 6 - Large AkroBins (Model 30239)

Accessories to fit 30" x 72" workbench

Package 1

- 2 - Bench Racks (Model 98636 Gray)
- 36 - Medium AkroBins (Model 30230)
- 6 - Large AkroBins (Model 30239)

Package 2

- 1 - Rail Kit
- 24 - Medium AkroBins (Model 30230)
- 6 - Large AkroBins (Model 30239)

Package 3

- 1 - Rail Kit
- 1 - 20-Drawer cabinet (Model 19320)
- 1 set - Suspension straps (Model 98400)
- 24 - Small AkroBins (Model 30220)
- 6 - Large AkroBins (Model 30239)

**HOW TO
CREATE
YOUR
MODEL
NUMBER**

Workbench	Size	Frame Color	Height Style	Shelf Options	Work Surface	Accessory Package	Bin Color
RHWB	3060 3072	G (Gray) B (Blue)	F (Fixed) A (Adjustable)	1 (Both Shelves Forward) 2 (Both Shelves Back) 3 (Middle Fwd, Bottom Back) 4 (Middle Back, Bottom Fwd)	S (Steel) P (Hardwood)	0 (none) 1 2 3	0 (none) 1 (Blue) 2 (Red) 3 (Stone) 4 (Yellow)
Example:	RHWB 3060	B	A	1	P	3	1

Example: For an adjustable height, 30" x 60" blue frame workbench with both shelves forward, a hardwood work surface, and accessory package # 3 with blue bins, your model number would be: **RHWB3060BA1P31**.

Mobile Work Tables



Heavy-Duty Work Table

- Industrial-grade mobile workstation with a welded-steel frame and steel-reinforced premium oak top - ships fully assembled.
- 24"L x 48"W work area with 9 adjustable height settings from 36" x 48".
- 5" x 2" bolted on polyurethane casters; two rigid, two swivel with total lock brakes.
- Wrap-around steel back stop keeps items from falling behind work table.
- Blue, Red, or Gray powder coated finish.
- **Model No. RHWB2448P5PY0.**
Please specify frame color.

Hardwood work surface extends 2" to accommodate a vise or clamps

Hardwood work surface with premium 1 1/4" (5/4") thick oak boards and rounded edges

21"D x 36"W bottom shelf

13 1/2"D x 37"W, tilted middle shelf for easy access to bins



Work Table with Accessory Package

Work Table with Accessory Package

- 24" x 48" Adjustable height work table.
- 1 - Rail Kit.
- 24 - Small AkroBins (Model 30220).
- 12 - Medium AkroBins (Model 30230).
- **Model No. RHWB2448P5PY1.**
Please specify frame color and bin color.

Medium-Duty Work Table

- Industrial-grade work table with steel-reinforced hardwood top - ships fully assembled.
- Size: 24"L x 48"W x 36"H.
- Two steel drawers - 15 1/2"W x 5 1/2"H x 16 1/2"D.
- 2 swivel, 2 rigid bolted-on soft rubber casters; 5" x 1 1/4". Total lock brakes on swivel casters.
- Frame colors: Red, Gray or Blue.
- **Model No. RMWB24485SRTP.**
Specify frame color when ordering.

Premium hardwood top

Handy, 13"W x 16" D x 5"H utility tray

Tubular push handle

Lips up on bottom shelf

13-gauge steel shelf





68-69

Wood Dollies

Quality wood dollies for many loading applications.



70

Polyethylene Dollies

High-impact, durable polyethylene construction.



70

Steel Dolles

Smooth rolling dollies for heavy-duty applications



70

Aluminum Dollies

Corrosion resistant, lightweight, and durable.



71

Hand Trucks

Medium and heavy-duty steel hand trucks for all types of loads.



72-73

Specialty Hand Trucks

Unique designs to transport cylinders or other odd-shaped loads.



74-75

Drum Handling Equipment

Equipment designed for operator safety and ease in handling or storing drums.

Trucks & Dollies

Dollies

Wood Dollies

- Constructed from select kiln-dried hardwoods to prevent warping and shrinkage.
- All boards are cut and planed to $\frac{7}{8}$ " with guaranteed consistent quality.
- Four, 3" polyolefin swivel casters offer 900 lb. capacity. (See caster options for up to 1,400 lb. capacity.)
- Shipped fully assembled.

Hardwood deck with countersunk bolt holes for a smooth working surface

Smooth open deck style features $\frac{7}{8}$ " thick, 4" wide rails for heavy-duty service



Non-marking, 3" swivel casters with polyolefin wheels have exceptional impact resistance

Zinc-plated rigs and hardware are resistant to corrosion

Solid Dolly

- Three cross battens on 36" and 48" length.
- Smooth, treated deck with countersunk bolts.
- Deck boards run lengthwise.



Model No.	Size			Wt.
	Inches	mm		
RD2416S3P	24 x 16	610 x 406	17 lbs.	
RD2718S3P	27 x 18	686 x 457	21 lbs.	
RD3018S3P	30 x 18	762 x 457	23 lbs.	
RD3624S3P	36 x 24	914 x 610	29 lbs.	
RD4824S3P	48 x 24	1219 x 610	36 lbs.	

Carpet End Dolly

- Padded carpeting protects furniture and appliances.



Model No.	Size			Wt.
	Inches	mm		
RD2416CE3P	24 x 16	610 x 406	14 lbs.	
RD2718CE3P	27 x 18	686 x 457	15 lbs.	
RD3018CE3P	30 x 18	762 x 457	16 lbs.	
RD3624CE3P	36 x 24	914 x 610	17 lbs.	

Flush Dolly

- Full, 4" wide by $1\frac{3}{4}$ " thick double length rails.
- Smooth, open deck.



Model No.	Size			Wt.
	Inches	mm		
RD2416F3P	24 x 16	610 x 406	16 lbs.	
RD2718F3P	27 x 18	686 x 457	17 lbs.	
RD3018F3P	30 x 18	762 x 457	19 lbs.	
RD3624F3P	36 x 24	914 x 610	21 lbs.	
RD4824F3P	48 x 24	1219 x 610	26 lbs.	

Rubber Cap Dolly

- Non-skid reinforced 3" wide rubber caps keep slippery loads in place without damage.



Model No.	Size			Wt.
	Inches	mm		
RD2718RC3P	27 x 18	686 x 457	15 lbs.	
RD3018RC3P	30 x 18	762 x 457	16 lbs.	

Regular Dolly

- Strength and reliability at an economy price.
- All rails are 4" wide.



Model No.	Size			Wt.
	Inches	mm		
RD2416R3P	24 x 16	610 x 406	13 lbs.	
RD2718R3P	27 x 18	686 x 457	14 lbs.	
RD3018R3P	30 x 18	762 x 457	15 lbs.	
RD3624R3P	36 x 24	914 x 610	16 lbs.	

All Carpet Solid Dolly

- Strength and reliability at an economy price.
- Fully carpeted* deck prevents damage to cargo.

*Pattern of carpet may vary.



Model No.	Size			Wt.
	Inches	mm		
RD2416AC3P	24 x 16	610 x 406	19 lbs.	
RD3018AC3P	30 x 18	762 x 457	23 lbs.	
RD3624AC3P	36 x 24	914 x 610	32 lbs.	

Dolly Options:



Wheel Locks

3", 4", 5" brake kits installed on 2 swivel casters.



Tow Eye R1495

Tow Handle R2515

Caster Options*

Model No.	Description	Capacity
3P	3" Polyolefin Casters	900 lbs.
4P	4" Polyolefin Casters	1200 lbs.
5P	5" Polyolefin Casters	1400 lbs.
3H	3" Hard Rubber Casters	900 lbs.
4H	4" Hard Rubber Casters	1200 lbs.
3R	3 $\frac{1}{2}$ " Non-Marking Rubber Casters	900 lbs.

Brake kits installed on two swivel casters – optional (non-returnable)

R1130	3" Brake Kits for Hard Rubber Casters
R1151	3" Brake Kits for Polyolefin Casters
R1146	4" Brake Kits
R1156	5" Brake Kits

*See page 76 for full description of casters and wheels.

Deck Heights by Caster Size:

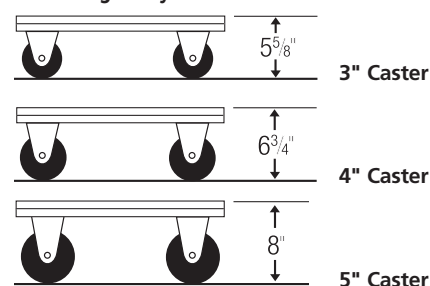

Wood Dolly Components

Our Premium Decks are constructed from the highest quality hardwoods to ensure maximum service under extreme conditions.

Premium Wood

- Select a dolly deck to replace a damaged deck or to fit your specialized casters.
- Dolly decks on this page do not include casters. See page 68 for complete dolly and caster packages.
- Premium decks are constructed from select hardwood boards for lasting strength and durability.
- Available in 1 1/4" (5/4) or 1" (4/4) thickness.
- Smooth, routed edges.

Premium deck order includes bolts and other hardware installed

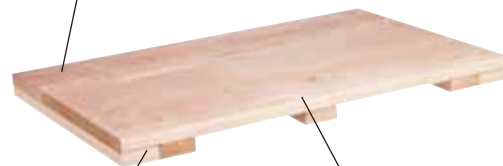

Select from 7/8" to 1 1/4" thickness

Smooth, routed edges

HOW TO ORDER

Order from the charts by specifying deck size (W x L), deck type, and thickness to create a model number.

Premium 5/4 (1 1/4") and 4/4 (1") Decks

Deck Size	Deck Type	Thickness
RPD1824	S	54*
RPD1830	F	44
RPD2436	CE	
	AC*	
	RC	
	R	

*Carpet Solid Dolly not available in 5/4 Premium Decks.

Example: RPD1824 S 44

For a premium 18" x 24" solid dolly deck with 4/4 (1") thickness, your model number will look like this: **RPD1824S44**

PREMIUM DECK SIZES

18" x 24"
18" x 30"
24" x 36"

Specify size when ordering.



Add optional casters and hardware to premium decks to create a premium dolly. See page 68 for options. Assembly required.

Solid Deck (S)



Flush Deck (F)



Carpet End Deck* (CE)



All Carpet Solid Dolly* (AC)

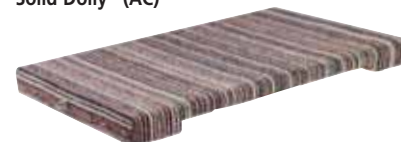

Rubber Cap Deck* (RC)**



Regular Deck (R)



* Installed hardware.

** Rubber cap only available on 27" x 18" and 30" x 18".

Standard Wood

- Select a dolly deck to replace a damaged deck or to fit your specialized casters.
- Dolly decks on this page do not include casters. See pages 68 for complete dolly and caster packages.
- Standard hardwood decks are 7/8" thick.
- Constructed from select kiln-dried hardwoods.

HOW TO ORDER

Order from the charts by specifying deck size (W x L) and deck type to create a model number.

Standard 7/8" Decks

Deck Size	Deck Type
RSD2416	S
RSD2718	F
RSD3018	CE
RSD3624	AC
RSD4824	RC
	R

Example: RSD2416 S

For a standard 24" x 16" solid dolly deck with 7/8" thickness, your model number will look like this: **RSD2416S**

STANDARD DECK SIZES

24" x 16"
27" x 18"
30" x 18"
36" x 24"
48" x 24"

Specify size when ordering.

Polyethylene Dollies

New!

- High-impact, durable polyethylene construction.
- Easy to clean, non-porous platform will not rot, mildew, or splinter.
- 1,200 lb. weight capacity.
- Quick, easy assembly.
- Colors: Blue or Gray.



1,200 lb. weight capacity – steel reinforced, one-piece deck design.

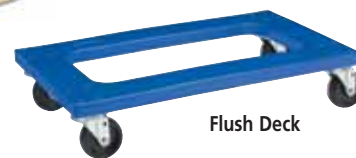

Flush Deck

Plate-style 4" polyolefin swivel casters for maximum maneuverability and easy replacement

Polyethylene Dollies

Model No.	Description	Dimensions		Overall Height		Color
		Inches	mm	Inches	mm	
RMD3018RC4PNA	Padded Deck Dolly	30 x18	762 x 457	8 ³ / ₄	222	Gray
RMD3018RC4PNAB	Padded Deck Dolly	30 x18	762 x 457	8 ³ / ₄	222	Blue
RMD3018F4PNA	Flush Deck Dolly	30 x18	762 x 457	7 ³ / ₄	197	Gray
RMD3018F4PNAB	Flush Deck Dolly	30 x18	762 x 457	7 ³ / ₄	197	Blue



Padded Deck

Steel Dollies

- Open structural angle dollies, 1¹/₂" x 1¹/₂" x 3¹/₁₆".
- Durable powder coated finish.
- Solid decks are smooth, 13-gauge steel.
- 1¹/₂" lip turned down for a smooth surface. Order lips up for a contained area.



Solid Deck Lips Down



Open Angle Lips Down



Solid Deck Lips Up



Open Angle Lips Up

Steel Dollies

Lips Down Model No.	Lips Up Model No.	Capacity	Caster Type*	Caster Size		Deck Height	
				Inches	mm	Inches	mm
Solid Dolly							
RD843HR	RU843HR	900 lbs.	Polyolefin	3 x 1 ¹ / ₄	76 x 32	3 ⁷ / ₈	98
RD843SS	RU843SS	1000 lbs.	Semi-Steel	3 x 1 ¹ / ₄	76 x 32	3 ⁷ / ₈	98
RD844HR	RU844HR	1200 lbs.	Polyolefin	4 x 1 ¹ / ₂	102 x 38	5 ¹ / ₈	130
RD844SS	RU844SS	1600 lbs.	Semi-Steel	4 x 1 ¹ / ₂	102 x 38	5 ¹ / ₈	130
Open Angle Structural Dolly							
RD853HR	RU853HR	900 lbs.	Polyolefin	3 x 1 ¹ / ₄	76 x 32	4	102
RD853SS	RU853SS	1000 lbs.	Semi-Steel	3 x 1 ¹ / ₄	76 x 32	4	102
RD854HR	RU854HR	1200 lbs.	Polyolefin	4 x 1 ¹ / ₂	102 x 38	5 ¹ / ₄	133
RD854SS	RU854SS	1600 lbs.	Semi-Steel	4 x 1 ¹ / ₂	102 x 38	5 ¹ / ₄	133

DECK SIZES

16" x 27" 18" x 30"
18" x 24" 24" x 36"
Specify size when ordering.

*See page 76 for full description of casters and wheels.

Wheel Specifications:



3" x 1¹/₄", 4" x 1¹/₂" Polyolefin

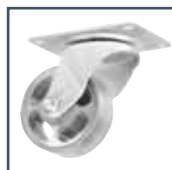

3" x 1¹/₄", 4" x 1¹/₂" Semi-Steel



4" x 1¹/₄" Resilex

Aluminum Dollies

New!

- Corrosion resistant, lightweight, and durable.
- 1¹/₂" lip turned down for a smooth surface or lips up for a contained area.
- Deck is bolted together with galvanized fasteners.
- Bolt-on swivel casters.
- Ships completely assembled and ready to use.



Lips Down



Lips Up

Aluminum Dollies

Lips Down Model No.	Capacity	Caster Type*	Caster Size		Deck Height	
			Inches	mm	Inches	mm
Lips Down						
RDADR4	1200 lbs	Resilex	4 x 1-1/4	102 x 32	6-3/4	171
RDADP4	1200 lbs	Polyolefin	4 x 1-1/4	102 x 32	6-3/4	171
Lips Up						
RDAUR4	1200 lbs	Resilex	4 x 1-1/4	102 x 32	8	203
RDAUP4	1200 lbs	Polyolefin	4 x 1-1/4	102 x 32	8	203

DECK SIZES

36" x 24" 30" x 18"
24" x 18"
Specify size when ordering.

*See page 76 for full description of casters and wheels.

Hand Trucks

Medium-Duty

- Medium-duty hand trucks for day-to-day work.
- Welded-steel construction supports up to 300 lbs.
- 7/8" OD structural pipe frame, 1/8" wall, 13-gauge.
- Standard 7" x 14" steel nose plate.
- Ships completely assembled and ready to use.
- 5/8" diameter axle.
- Two position bracket fits 8" or 10" wheels.
- Heavy flat bar and tube for climbing stairs.
- Optional 10" x 14" or 14" x 14" nose plates available.

*Special-order products are not returnable.

Heavy-Duty

- Heavy-duty hand trucks for all types of loads.
- Welded-steel hand trucks support up to 500 lbs.
- 1" OD structural pipe frame, 13-gauge steel.
- 5/8" diameter axle.
- Standard 8" x 14" steel nose plate.
- Optional 10" x 14" or 14" x 14" noseplate available.*
- Two position bracket fits 8" or 10" wheels.
- Deep-V cross straps available for specialized loads.*

*Special-order products are not returnable.

Wheel Specifications:
Caster & Wheel choices allow you to resolve problems of noise control, floor protection, impact or abrasion resistance, or load capacity. See page 76 for more caster information.



Semi-Pneumatic
10" x 2.75"



Full Pneumatic
10" x 3.50"



Moldon Rubber
8" x 2"



Optional 24" folding nose extensions available. Suffix FN to any model no. Not intended for field installation. (Special-order products are not returnable.)

Handle Styles:



Flow Back



Dual Grip with Vinyl Grips



Vertical Single Loop



Dual Loop

Medium-Duty Hand Trucks

Model No.	Wheel Type	Wheel Size Inches	Wheel Size mm	Overall Height Inches	Overall Height mm	Overall Width Inches	Overall Width mm	Ship Wt.
Flow Back								
R3008MR	Moldon Rubber	8	203	45	1143	19 3/4	498	37 lbs.
R3010FP	Full Pneumatic	10	254	45	1143	22	559	35 lbs.
R3010SP	Semi-Pneumatic	10	254	45	1143	20	508	35 lbs.
Dual Grip								
R3208MR	Moldon Rubber	8	254	47	1194	20	508	35 lbs.
R3210FP	Full Pneumatic	10	254	47	1194	20	508	35 lbs.
R3210SP	Semi-Pneumatic	10	254	47	1194	20	508	35 lbs.

Heavy-Duty Hand Trucks

Model No.	Wheel Type	Wheel Size Inches	Wheel Size mm	Overall Height Inches	Overall Height mm	Overall Width Inches	Overall Width mm	Ship Wt.
Flow Back								
R4008MR	Moldon Rubber	8	203	45	1143	19 3/4	502	43 lbs.
R4008MR2	Moldon Rubber	8	203	52	1321	19 3/4	502	48 lbs.
R4010FP	Full Pneumatic	10	254	45	1143	22	559	41 lbs.
R4010FP2	Full Pneumatic	10	254	52	1321	22	559	46 lbs.
R4010SP	Semi-Pneumatic	10	254	45	1143	20	508	41 lbs.
R4010SP2	Semi-Pneumatic	10	254	52	1321	22	559	46 lbs.
Vertical Single Loop								
R4108MR	Moldon Rubber	8	203	46	1168	19 3/4	502	43 lbs.
R4108MR2	Moldon Rubber	8	203	53	1346	19 3/4	502	48 lbs.
R4110FP	Full Pneumatic	10	254	46	1168	20	508	41 lbs.
R4110FP2	Full Pneumatic	10	254	53	1346	22	559	46 lbs.
R4110SP	Semi-Pneumatic	10	254	46	1168	20	508	41 lbs.
R4110SP2	Semi-Pneumatic	10	254	53	1346	20	508	46 lbs.
Dual Grip								
R4208MR	Moldon Rubber	8	203	47	1194	20	508	43 lbs.
R4208MR2	Moldon Rubber	8	203	51	1295	20	508	48 lbs.
R4210FP	Full Pneumatic	10	254	47	1194	22	559	41 lbs.
R4210FP2	Full Pneumatic	10	254	51	1295	22	559	46 lbs.
R4210SP	Semi-Pneumatic	10	254	47	1194	20	508	41 lbs.
R4210SP2	Semi-Pneumatic	10	254	51	1295	20	508	46 lbs.
Dual Loop								
R4510SP	Semi-Pneumatic	10	254	46	1168	20	508	41 lbs.
R4510SP2	Semi-Pneumatic	10	254	53	1346	20	508	46 lbs.

Custom engineered products can be designed and produced to your application/specification needs. For more information call your Akro-Mils distributor.

Specialty Hand Trucks

Cylinder/Gas Trucks



Single 330 Cu. Ft. Cylinder Truck

- Designed to handle 330 cu. ft. cylinder.
- Two rear casters provide added stability.
- Includes heavy-duty holding chain.
- Color: Yellow.

Model No.	Wheel Type	Wheel Size Inches	Wheel Size mm
RCTD40SP	Semi-Pneumatic	10 x 2 ³ / ₄	254 x 70
Base Plate - 14"W x 6"D (356 x 152mm)		OAH - 45"	1143



Single & Dual Gas Trucks

- Heavy-duty truck designed to handle 330 cu. ft. cylinders.
- Available in single and dual cylinder models.
- Includes heavy-duty holding chain.
- Hard rubber swivel caster.
- Color: Yellow.

Model No.	Description	Wheel Type	Wheel Size Inches	Wheel Size mm
RGTS10FP	Single	Full Pneumatic	10 x 3 ¹ / ₂	254 x 89
RGTD10FP	Dual	Full Pneumatic	10 x 3 ¹ / ₂	254 x 89
RGTS10SP	Single	Semi-Pneumatic	10 x 2 ³ / ₄	254 x 70
RGTD10SP	Dual	Semi-Pneumatic	10 x 2 ³ / ₄	254 x 70
Base Plate - 14"W x 6"D (356 x 152mm)			OAH - 45"	1143



Dual Cylinder Truck with T-Handle

- Handles cylinders in a medium-duty application.
- Priced economically with its T-handle design.
- Two heavy-duty holding chains and tool tray.
- Color: Yellow.

Model No.	Wheel Type	Wheel Size Inches	Wheel Size mm
RCT40LW	Lightweight	8 x 1 ³ / ₄	203 x 44
Base Plate - 17"W x 8"D (432 x 203mm)		OAH - 43"	1092



Single Cylinder Hand Truck

- Perfect for medium to large cylinders.
- Also transports boxes or other bulky items.
- Includes heavy-duty holding chain.
- Color: Yellow.

Model No.	Wheel Type	Wheel Size Inches	Wheel Size mm
RCTV40SP	Semi-Pneumatic	10 x 2 ³ / ₄	254 x 70
Base Plate - 14"W x 7"D (356 x 178mm)		OAH - 48"	1219



Dual Cylinder Truck with Dual Handle

- Carries cylinders in a medium-duty application.
- Welded tank holders.
- Two heavy-duty holding chains and tool tray.
- Dual handle with vinyl grips.
- Color: Yellow.

Model No.	Wheel Type	Wheel Size Inches	Wheel Size mm
RCT50SP	Semi-Pneumatic	10 x 2 ³ / ₄	254 x 70
Base Plate - 20"W x 9"D (508 x 229mm)		OAH - 45"	1143



Dual Cylinder Truck with Continuous Handle

- Heavy-duty truck accommodates most cylinder tanks.
- Includes heavy-duty holding chain and tool tray.
- Easily carries two 300 cu. ft. tanks.
- Color: Yellow.

Model No.	Wheel Type	Wheel Size Inches	Wheel Size mm
RCT30FP	Full Pneumatic	10 x 3 ¹ / ₂	254 x 89
RCT30SP	Semi-Pneumatic	10 x 2 ³ / ₄	254 x 70
Base Plate - 20"W x 11"D (508 x 279mm)		OAH - 39"	991

Dual-Purpose Hand Truck

- Dual-function hand truck converts to platform position for oversize loads.
- 40"H hand truck.
- 37"L platform bed.
- Welded, 1" structural pipe frame with 1/8" walls.
- Large, 7" x 14" nose plate.
- Up to 600 lbs. capacity in platform mode.
- Color: 4008 Model is Red, 4010 Models are Silver.

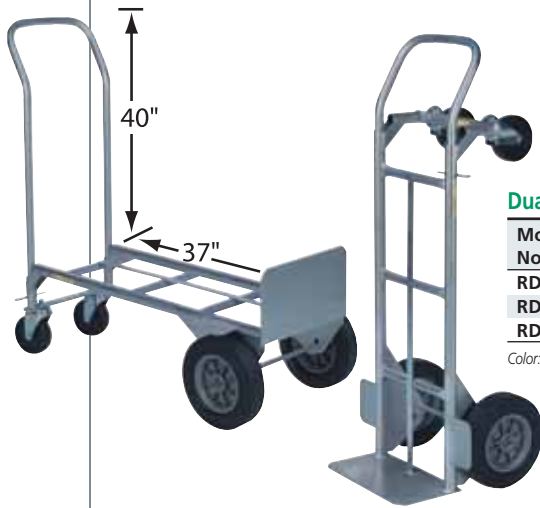

Dual-Purpose Hand Truck

Model No.	Wheel Type	Wheel/Caster Size	Overall Height Inches	Overall Height mm	Overall Width Inches	Overall Width mm	Ship Wt.
RDT4008SP	Semi-Pneumatic	8"/3" (203/76)	46	1168	19 ⁹ / ₁₆	498	46 lbs.
RDT4010FP	Full Pneumatic	10"/5" (254/127)	46	1168	22	559	50 lbs.
RDT4010SP	Semi-Pneumatic	10"/5" (254/127)	46	1168	20	508	50 lbs.

Color: 4008 Model is Red, 4010 Models are Silver.

Pail Truck



- Multi-purpose hand truck for carting 5-gallon pails.
- Cross straps with supporting arms hold pails in place while in transit.
- Welded, 1" structural pipe frame with 1/8" walls.
- Up to 300 lbs. capacity.
- RPT40 holds 4 pails, RPT50 holds 5 pails.

Pail Truck

Model No.	Wheel Type	Wheel Size Inches	Wheel Size mm	Overall Height Inches	Overall Height mm	Overall Width Inches	Overall Width mm	Ship Wt.
RPT4010SP	Semi-Pneumatic	10	254	55	1397	18	457	46 lbs.
RPT5010SP	Semi-Pneumatic	10	254	67 ¹ / ₂	1715	18	457	50 lbs.

Drum Handling Equipment

Drum Hand Truck

- Transport 30 and 55-gallon drums with ease.
- Strong rugged construction for heavy-duty drum handling.

Drum Hand Truck

Model No.	Wheel Type	Wheel Size Inches	Wheel Size mm	Roller Bearing	Load Capacity
R9508MR	Moldon	8 x 2	203 x 51	3/4" (19mm)	1000 lbs.
R9510MR	Moldon	10 x 2 1/2	254 x 64	1" (25mm)	1200 lbs.



Spill-less Open Drum Truck

- Easily transports open drums, reduced danger of spillage.
- Handles 55-gallon drums.

Spill-less Open Drum Truck

Model No.	Description	Wheel Size Inches	Wheel Size mm
R93	Rigid Handle	6 x 2	152 x 51
R93H	Hinged Handle	6 x 2	152 x 51

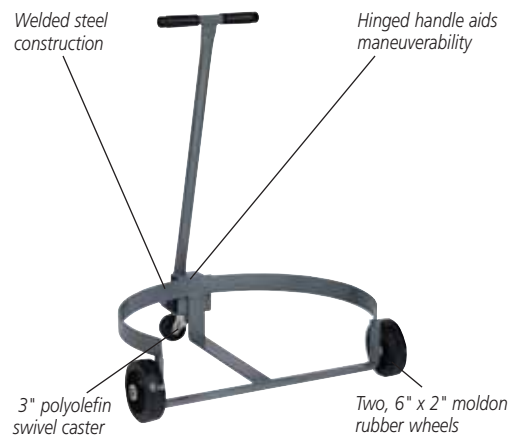

Cradle Combo Truck



- A drum truck and cradle in one.
- Distributes weight over four wheels for operator safety.
- Handles 30 and 55-gallon drums with ease.

Cradle Combo Truck

Model No.	Wheel Type	Wheel Size Inches	Wheel Size mm	Roller Bearing	Load Capacity
R9508MR2	Moldon	8 x 2	203 x 51	3/4" (19mm)	1000 lbs.
R9510MR2	Moldon	10 x 2 1/2	254 x 64	1" (25mm)	1200 lbs.
		6 x 2	152 x 51	3/4" (19mm)	



Drum Dollies



Drums load easily onto this cross-style dolly.

- For the ease of rolling 30 and 55-gallon drums.



Cross-Style

Model No.	Wheel Type	Load Capacity	Diameter
R9030HR	3" Swivel Polyolefin	900 lbs.	20 1/4 ID
R9055HR	3" Swivel Polyolefin	900 lbs.	24 1/4 ID
R9030SS	3" Swivel Semi-Steel	1000 lbs.	20 1/4 ID
R9055SS	3" Swivel Semi-Steel	1000 lbs.	24 1/4 ID
R9055HR	5" Swivel Polyolefin	1500 lbs.	24 1/4 ID



Ring Dollies

Model No.	Wheel Type	Load Capacity	Diameter
R9230HR	3" Swivel Polyolefin	900 lbs.	19 1/2 ID
R9255HR	3" Swivel Polyolefin	900 lbs.	23 1/2 ID
R9230SS	3" Swivel Semi-Steel	1000 lbs.	19 1/2 ID
R9255SS	3" Swivel Semi-Steel	1000 lbs.	23 1/2 ID
R9255HR	5" Swivel Polyolefin	1500 lbs.	23 1/4 ID

Drum Racks

- Allows for easy handling and storage of drums.
- Saves storage space.
- Heavy-duty welded steel construction.
- Accessible with fork lift from all sides.
- Racks can be stacked to store additional drums.

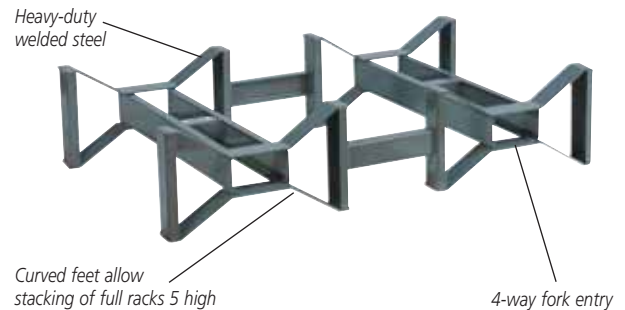

Drum Racks

Model No.	Description	Size (H x W x L) Inches	mm	Single Rack Load Capacity
R992	Two-Drum Rack	10 x 45 1/2 x 28	254 x 1156 x 711	1600 lbs.
R993	Three-Drum Rack	10 x 74 x 28	254 x 1880 x 711	2400 lbs.

Drum Cradles

- Drum cradles allow easy transport and draining of 55-gallon drums.
- Single and dual handles retract for storage.
- Cradles support loads to 600 lbs.
- Some assembly required.
- Model R91HW2 has swivel casters to allow easier turning in limited space. Two handles provide greater stability and operator control.



Drain 55-gallon drums easily with drum cradles.



Drum Cradles

Model No.	Description
R91HW	With 1 Handle and 4 Rigid Wheels
R91HW2	With 2 Handles and 2 Swivel Casters, 2 Rigid Wheels

Materials Definitions & Benefits











Each resin has properties that make it ideal for a specific purpose. We manufacture our plastic products using the grade most suited to the product's end use. Listed below are the quality resins we use and their attributes. Akro-Mils reserves the right to change product materials without notice.

- Polypropylene**
 Rigid and very strong. High impact resistance. Hard surface resists scratches. Withstands temperatures between -20 and 150°F.
- Co-Polymer Polyethylene**
 Unique additives increase impact resistance over standard high-density polyethylene.
- Structural Foam/Web**
 Advanced molding process makes an extremely durable product that will withstand heavy loads and high levels of abuse. Withstands temperatures between -30 and 120° F.
- Co-Polymer Polypropylene**
 Unique additives increase strength, rigidity, and impact resistance.
- Polystyrene**
 More flexible to withstand impacts. Withstands temperatures between -30 and 115° F.
- FDA Approved Materials**
 Resins and colorants are FDA-approved for use in the food industry.
- High Density Polyethylene**
 Extremely rigid and very strong. Highly impact and chemical resistant. Extremely hard surface is resistant to scratches. Withstands temperatures between -20 and 150° F.
- High-Impact Polystyrene**
 A part of the Styrene family, but superior in UV, impact, and weather resistance. High-gloss surface. Withstands temperatures up to 180°F.
- ESD Materials**
 Provides the highest degree of electrostatic discharge protection available with consistent uniform surface resistivities in the static dissipative range of 10⁶-10⁹ ohms/sq.

Casters & Wheels

A generous selection of caster and wheel options allows Platform Trucks, Hand Trucks, Dollies, and Shelf Carts to be customized to fit hundreds of applications, surfaces, and conditions. Caster and wheel choices allow you to resolve problems of noise control, floor protection, impact and abrasion resistance, or load capacity.

Caster Types

 <p>Phenolic Economical, high-capacity wheel rolls easily and is resistant to chemicals and oils.</p>	 <p>Polyurethane A heavy-duty wheel with polyurethane cushion tread bonded to a cast iron core. Resists most chemicals and oils.</p>	 <p>Moldon Rubber A quiet, shock-absorbing wheel with rubber cushion tread bonded to a cast iron core.</p>	 <p>Non-Marking Soft rubber cushion tread on polished aluminum hub provides maximum floor protection and shock resistance.</p>	 <p>Hi-Tech Performa Wheels Hi-Tech Performa wheels in flat or round tread designs, resist damage from weather, water, steam, or metal shavings. Thermoplastic elastomer treads are load-rated up to 500 lbs. per wheel.</p>
 <p>Steel Extremely durable, high-capacity cast iron wheel rolls easily under heavy loads and is highly resistant to abrasion.</p>	 <p>Polyolefin A heavy-duty, lightweight, non-marking plastic wheel that resists most chemicals and oils, and has excellent impact resistance.</p>	 <p>Semi-Pneumatic Co-polymer polypropylene wheel on an aluminum hub. Specifically designed for material handling equipment.</p>	 <p>Full Pneumatic Air-filled for excellent shock protection, floor protection, and easy operation over rough surfaces.</p>	 <p>Pro-Tech Wheels The Pro-Tech polyurethane wheel is a non-marking, cushion ride design that can be ordered with non-metallic, delrin bearings that are unaffected by water, steam, oil, and most acids. Pro-Tech wheels are load-rated up to 750 lbs.</p>

Caster Composition	Floor Surface									Floor Coverings						Other Factors To Consider							
	Asphalt	Brick/Ceramic Tile	Carpet	Concrete	Linoleum	Steel Ribbed	Steel Smooth	Wood	Animal Fats	Chemicals - Harsh	Chemicals - Mild	Metal Chips - Small	Metal Straps - Large	Oil & Grease	Water & Steam	Floor Protection	Noise	Cushion Load	Impact Resistance	Capacity	Rolling Ease	Abrasion Resistance	
E= Excellent G= Good F= Fair NR= Not Recommended																							
Standard Caster/Wheels																							
Polyolefin	F	F	G	G	F	F	G	G	G	F	G	G	NR	G	E	G	F	NR	G	G	E	G	G
Moldon Rubber	E	E	E	E	E	G	G	E	G	F	F	E	E	F	G	E	E	E	E	F	F	F	F
Pneumatic	E	E	E	E	E	E	E	E	G	F	F	G	G	F	G	E	E	E	E	F	F	F	F
Steel	NR	NR	NR	F	NR	NR	G	F	G	F	G	G	NR	G	F	NR	F	NR	NR	E	E	E	E
Polyurethane	E	E	G	E	E	G	G	E	G	G	G	G	G	G	E	E	G	G	E	E	G	E	E
Phenolic	NR	NR	NR	G	E	NR	G	G	G	F	G	F	NR	E	E	E	E	NR	E	E	E	E	G
Pro-Tech Performa	E	E	G	E	E	G	G	E	G	G	G	G	G	G	E	E	G	G	E	G	E	G	E
Black Flat 5"	E	E	G	E	E	G	G	E	G	G	G	G	G	G	E	E	G	G	E	G	E	E	E
Gray Round 8"	E	E	G	E	E	G	G	E	G	G	G	G	G	G	E	E	G	G	E	G	E	E	E

Index

2420.....	49	30016.....	8	30930.....	52	39085.....	20	77410.....	41
5705.....	48	30101.....	11	30936.....	52	39120.....	20	77505.....	41
5709.....	48	30102.....	11	33101.....	23	39170.....	20	77510.....	41
5805.....	48	30110.....	11	33105.....	23	40120.....	11	77610.....	41
5807.....	48	30120.....	11	33161.....	23	40130.....	11	78100.....	41
5905.....	48	30124.....	11	33164.....	23	40150.....	11	79465.....	39
6115.....	47	30128.....	11	33168.....	23	40170.....	11	79496.....	39
6118.....	47	30130.....	11	33220.....	23	40220.....	6	79565.....	39
6217.....	47	30138.....	11	33221.....	23	40228.....	46	79596.....	39
8146.....	49	30148.....	8	33224.....	23	40230.....	6	95418.....	53
8166.....	49	30150.....	11	33226.....	23	40239.....	6	95492.....	53
8186.....	49	30158.....	11	33228.....	23	40245.....	6	98325.....	46
9185.....	27	30164.....	11	34240.....	28	40265.....	6	98400.....	46
9514.....	49	30170.....	11	34301.....	28	40270.....	6	98600.....	7,15
9517.....	49	30174.....	11	34302.....	28	40320.....	46	98636.....	7,15
9912.....	49	30178.....	11	34303.....	28	40410.....	11	075-611.....	38
9920.....	49	30184.....	11	34304.....	28	40416.....	46	08024RED.....	49
10116.....	47	30210.....	6	35010.....	18,23	40445.....	11	30120ESD.....	15
10124.....	47	30211.....	6	35011.....	23	40501.....	46	30124ESD.....	15
10126.....	47	30220.....	6	35180.....	18	40715.....	46	30128ESD.....	15
10144.....	47	30221.....	6	35181.....	18	40901.....	46	30210ESD.....	15
10164.....	47	30224.....	6	35185.....	18	40909.....	46	30220ESD.....	15
11020.....	19	30230.....	6	35190.....	18	41105.....	23	30230ESD.....	15
13014.....	10	30231.....	6	35191.....	18	41164.....	23	30235ESD.....	15
13017.....	10	30234.....	6	35195.....	18	41166.....	23	30240ESD.....	15
13018.....	10	30235.....	6	35200.....	18	41168.....	23	30265.....	6
14212.....	49	30236.....	6	35201.....	18	41220.....	23	30270.....	6
14217.....	49	30239.....	6	35225.....	18	41224.....	23	30716 BLACK.....	14
17018.....	46	30240.....	6	35230.....	18	41226.....	23	30718 BLACK.....	14
17136.....	46	30250.....	6	35231.....	18	41228.....	23	30776 BLACK.....	14
19109.....	46	30255.....	6	35240.....	18	42105.....	23	30778 BLACK.....	14
19228.....	46	30280.....	10	35241.....	18	42164.....	23	30796 BLACK.....	14
19320.....	46	30281.....	10	35300.....	18	42166.....	23	30945 GRAY.....	43
19416.....	46	30282.....	10	35301.....	18	42168.....	23	30955BLGRY.....	42
19715.....	46	30283.....	10	37208.....	24	42220.....	23	30955BRGRY.....	42
19909.....	46	30290.....	10	37278.....	24	42224.....	23	30955SHELF.....	42
20228.....	46	30348.....	14	37288.....	24	42226.....	23	33164ESD.....	15
20320.....	46	30358.....	14	37608.....	24	42228.....	23	33224ESD.....	15
20416.....	46	30424.....	8,46	37612.....	24	76460.....	40	3H.....	68
20502.....	46	30618.....	7,15	37616.....	24	76461.....	40	3P.....	68
20715.....	46	30626.....	7,15	37672.....	24	76490.....	40	3R.....	68
20902.....	46	30636.....	7,15	37676.....	24	76491.....	40	4H.....	68
20909.....	46	30653.....	7,15	37678.....	24	76590.....	40	4P.....	68
30006.....	8	30812.....	8	37682.....	24	76591.....	40	5P.....	68
30008.....	8	30900.....	53	37686.....	24	77002.....	41	66486CLDBL.....	19
30012.....	8,46	30906.....	53	37688.....	24	77405.....	41	66497CLDGN.....	19

Index

66499CLSL 19	AR27171202 21	DR21150100 22	R1512FP2 61	R4208MR2 71
AB21150900 22	AS1275 12	DR24200100 22	R155HR 61	R4210FP 71
AC3618 9	AS1275110Y 12	DY22190700 30	R155HR2 61	R4210FP2 71
AC3618QV 9	AS1275120Y 12	HH19110700 26	R155HR2LD 61	R4210SP 71
AC3618QV240 9	AS1275130Y 12	HH24110900 26	R158FP2 61	R4210SP2 71
AC3618QV250 9	AS1275150Y 12	HI20140300 27	R158MR 61	R4510SP 71
AC3618SV 9	AS1275170Y 12	HI20140320 27	R158MR2 61	R4510SP2 71
AC3618SV240 9	AS1875 12	HI20140400 27	R158MR2LD 61	R45T5HR 61
AC3618SV250 9	AS1875128Y 12	HI20140420 27	R2108FPB 60	R45T8MR 61
AC3618Y 9	AS187513014 12	HL14100000 26	R21210FPB 60	R55T5HR 61
AC3624 9	AS187513017 12	HL21130000 26	R2125MRB 60	R55T8MR 61
AC36243AS 9	AS187513018 12	HS22130600 27	R21412FPB 60	R6100 58
AC3624Y 9	AS1875138Y 12	HS24160900 27	R2146MRB 60	R6101 58
AC3624Y3AS 9	AS1875158Y 12	HS28170900 27	R214HE 63	R6111 58
ACR-2 40	AS1875178Y 12	HT15100600 26	R214HEGA 63	R6121 58
ACR-3 40	AS187536 12	HT15100622 26	R215HE 63	R6131 58
ACR-4 40	AS187542 12	HT16100422 26	R2161012FPB 60	R6139 58
ACR-6 40	AS1875ASSOR 12	HT19100400 26	R2165PLB 60	R6141 58
AF21150602 22	AS21151702 21	HT19100422 26	R2165PYB 60	R6144 58
AG20160422 29	AS22131202 21	HT22130600 26	R2165SSB 60	R6151 58
AG24160752 29	AS28211502 21	HT22130622 26	R2168MRB 60	R6170 58
AP22161000 21	AS34242012 21	JL25160968 29	R25T5HR 61	R6171 58
APRBENCH 13	BG48403302 33	LJ25160200 29	R25T8MR 61	R6175 58
APRBENCH 120 13	BH48403420 32	MP24200722 31	R2T5HR 63	R6180 58
APRBENCH 150 13	BH48453420 32	NL24160259 30	R2T8MR 63	R6181 58
APRC 9	BS32302500 33	NP24160887 30	R3008MR 71	R6191 58
APRC120Y 9	BS32303420 33	NP24161194 30	R3010FP 71	R6193 58
APRD 13	BS64483411 32	NP24161195 30	R3010SP 71	R6194 58
APRD110Y 13	BX48452520 38	PM484006001 34	R3208MR 71	R6199 58
APRD120Y 13	BX48453420 33	PM484006331 34	R3210FP 71	R7208PL 59
APRD130Y 13	BX48453420 38	PM484806001 34	R3210SP 71	R7218PL 59
APRD150Y 13	C18-541E 30	PM484806331 34	R35T5HR 61	R746MR 59
APRD170Y 13	C75-605 38	PS484006001 35	R35T8MR 61	R756MR 59
APRDMOBILE 13	CC20141122 29	PS484006331 35	R4008MR 71	R768MR 59
APRS 13	CD28260120 31	PU484006331 35	R4008MR2 71	R778MR 59
APRS110Y 13	CP24200760 30	R1130 68	R4010FP 71	R786PL 59
APRS120Y 13	CP24201060 30	R1146 68	R4010FP2 71	R796PL 59
APRS130Y 13	CP24201360 30	R1151 68	R4010SP 71	R90000 57
APRS150Y 13	CT29260922 31	R1156 68	R4010SP2 71	R90031 61
APRS170Y 13	DL21150512 22	R120DS 59	R4108MR 71	R90041 61
AR15141300 21	DL21150712 22	R121DS 59	R4108MR2 71	R90062 61
AR20120702 21	DL21150900 22	R1B5HR 63	R4110FP 71	R90110 55
AR21150902 21	DL21151202 22	R1B5HRLD 63	R4110FP2 71	R90152 55
AR21151202 21	DL24200614 22	R1B5HRX 63	R4110SP 71	R90153 55
AR24201202 21	DL24201014 22	R1B5HRXLD 63	R4110SP2 71	R90162 55
AR27170902 21	DL24201202 22	R1S10FP2 61	R4208MR 71	R90163 55

Index

R90164 55	R9508MR2 74	RD844SS 70	RPTD27541 58	RWHV24481A5Y6A . . . 59
R90181 55	R9510MR 74	RD853HR 70	RPTD27542 58	RWHV30601A5M6 . . . 59
R90182 55	R9510MR2 74	RD853SS 70	RPTD30601 58	RWHV30601A5M6A . . 59
R90183 55	R96015 55	RD854HR 70	RPTD30602 58	RWHV30601A5M8 . . . 59
R90184 55	R96017 55	RD854SS 70	RPTD36721 58	RWHV30601A5M8A . . 59
R90185 55	R992 75	RDADP4 70	RPTD36722 58	RWHV30601A5Y6 . . . 59
R90210 55	R993 75	RDADR4 70	RSD2416 69	RWHV30601A5Y6A . . 59
R90252 55	RA121DS 59	RDAUP4 70	RSD2718 69	SL12070100 25
R90253 55	RA6TR4MR 28	RDAUR4 70	RSD3018 69	SL15120100 25
R90262 55	RA7218PL 59	RDT4008SP 73	RSD3624 69	SL24110100 25
R90263 55	RA756MR 59	RDT4010FP 73	RSD4824 69	SL24150100 25
R90264 55	RA778MR 59	RDT4010SP 73	RU842HR2018 10	SL24220100 25
R90281 55	RA796PL 59	RGTD10FP 72	RU842HR2918 10	SN15120709 19
R90282 55	RC25171401 38	RGTD10SP 72	RU843HR 70	SN24150709 19
R90283 55	RCT30FP 72	RGTS10FP 72	RU843HR1420 20	SN24150999 19
R90284 55	RCT30SP 72	RGTS10SP 72	RU843HR1422 18	SN24220913 19
R90285 55	RCT40LW 72	RHWB2448P5PY0 . . . 65	RU843HR1519 10	SN24221113 19
R9030HR 75	RCT50SP 72	RHWB2448P5PY1 . . . 65	RU843HR1617 10	SW12070502 25
R9030SS 75	RCTD40SP 72	RHWB3060 64	RU843HR1621 23	SW15120602 25
R90555HR 75	RCTV40SP 72	RHWB3072 64	RU843HR1624 24	SW151208A2 25
R9055HR 75	RD2416AC3P 68	RM716MR 59	RU843HR1822 18	SW15121002 25
R9055SS 75	RD2416CE3P 68	RM716PL 59	RU843HR1828 18	SW24111002 25
R91HW 75	RD2416F3P 68	RM718MR 59	RU843SS 70	SW241504A2 25
R91HW2 75	RD2416R3P 68	RM718PL 59	RU844HR 70	SW24150602 25
R9230HR 75	RD2416S3P 68	RMD2104MRA 60	RU844SS 70	SW241508A2 25
R9230SS 75	RD2718CE3P 68	RMD2105SRA 60	RU853HR 70	SW24151002 25
R92411 55	RD2718F3P 68	RMD2ST5SR 62	RU853SS 70	SW241511A2 25
R92412 55	RD2718R3P 68	RMD3018F4PNA . . . 70	RU854HR 70	SW24151502 25
R92413 55	RD2718RC3P 68	RMD3018F4PNAB . . . 70	RU854SS 70	SW24220802 25
R92414 55	RD2718S3P 68	RMD3018RC4PNA . . . 70	RWH24481A5M6 59	SW24221102 25
R92416 55	RD3018AC3P 68	RMD3018RC4PNAB . . 70	RWH24481A5M6A . . . 59	SW32150802 25
R92418 55	RD3018CE3P 68	RMD3ST5SR 62	RWH24481A5M8 59	SW48150802 25
R92555HR 75	RD3018F3P 68	RMWB24485SRTP . . . 65	RWH24481A5M8A . . . 59	SX151208A4 25
R9255HR 75	RD3018R3P 68	RPD1824 69	RWH24481A5Y6 59	SX241504A4 25
R9255SS 75	RD3018RC3P 68	RPD1830 69	RWH24481A5Y6A . . . 59	SX241508A4 25
R93 74	RD3018S3P 68	RPD2436 69	RWH30601A5M6 59	SX24151000 25
R93011 55	RD3624AC3P 68	RPT2448 57	RWH30601A5M6A . . . 59	SX241511A4 25
R93012 55	RD3624CE3P 68	RPT2754 57	RWH30601A5M8 59	SX48150800 25
R93013 55	RD3624F3P 68	RPT2ST5SR 62	RWH30601A5M8A . . . 59	TH484002001 32
R93014 55	RD3624R3P 68	RPT3060 57	RWH30601A5Y6 59	TH484502001 32
R93016 55	RD3624S3P 68	RPT3672 57	RWH30601A5Y6A . . . 59	TS32300200 33
R93019 55	RD4824F3P 68	RPT3ST5SR 62	RWHV24481A5M6 . . . 59	TS48400200 33
R93H 74	RD4824S3P 68	RPT4010SP 73	RWHV24481A5M6A . . 59	TS48450300 33
R94815 55	RD843HR 70	RPT5010SP 73	RWHV24481A5M8 . . . 59	TS48450300 38
R94817 55	RD843SS 70	RPTD24481 58	RWHV24481A5M8A . . 59	
R9508MR 74	RD844HR 70	RPTD24482 58	RWHV24481A5Y6 . . . 59	

Discover Unmatched Opportunities For Your Plastic & Rubber Needs with these Industry-Leading Companies from Myers Industries...



Ameri-Kart™ is a top producer of rotationally-molded and vacuum-formed plastic waste hauling and material handling carts for industrial, commercial, and residential use, as well as custom plastic parts for RV, automotive, industrial, and heavy-truck OEMs.



Allibert-Buckhorn™ is the European leader in reusable plastic pallets, hand-held totes, bulk transport containers, IBC's, and custom material handling products for automotive, industrial, agriculture, food, chemical, and retail distribution markets.



Buckhorn is a North American leader in plastic reusable hand-held totes, pallets and a comprehensive range of bulk transport containers. Diverse engineering and manufacturing capabilities provide single-source value for design and production of custom material handling products.



Solutions Abound...

Myers Industries, Inc. (NYSE: MYE) is an international manufacturer of polymer products for industrial, agricultural, automotive, commercial and consumer markets. In addition to the material handling brands featured, product solutions both standard and custom are available from Myers' other industry-leading companies:



Dillen Products®— North America's foremost manufacturer of horticultural pots, trays, hanging baskets, and related items for growers, nurseries, and retail garden centers.



Listo Products™— The premier innovator in the design and molding of decorative resin planters with unique textures and color effects, serving the retailer/consumer.



Pro Cal™— Manufactures a variety of injection-molded and pressure-formed nursery pots and specialty graphic containers for professional growers.



Buckhorn Rubber Products™— A leading producer of engineered, molded rubber hoses, seals, and other custom parts for markets including agriculture, heavy-truck, construction, and water control.



Michigan Rubber Products™— A top designer and manufacturer of rubber components, systems, and assemblies for the automotive industry.



WEK Industries™— Sets the standard for engineered, plastic blow-molded components for automotive, motorcycle, and all-terrain vehicles.



Patch Rubber™— Produces the largest selection of tire repair and retread products in the U.S., specialty items such as reflective highway tapes, and custom rubber sheet stock.



raaco International®— The European solution for plastic bins and storage systems serving industrial and commercial markets.



Myers Tire Supply®— The largest U.S. distributor of tools, equipment, and supplies for tire, wheel, and undervehicle service professionals.

Learn More at www.myersind.com

